

TOSHIBA Photocoupler Infrared LED + Photo IC

# TLP550

- Digital Logic Isolation
- Line Receiver Feedback Control
- Power Supply Control
- Switching Power Supply
- Transistor Inverter

TLP550 constructs a high emitting diode and a one chip photo diode-transistor.  
 TLP550 has no base connection, and is suitable for application at noisy environmental condition.  
 This unit is 8-lead DIP package.

- Isolation voltage: 2500 Vrms (min.)
- Switching speed:  $t_{pHL}, t_{pLH} = 0.5\mu s$  (typ.) ( $R_L = 1.9 k\Omega$ )
- TTL compatible
- UL recognized: UL1577, file No. E67349

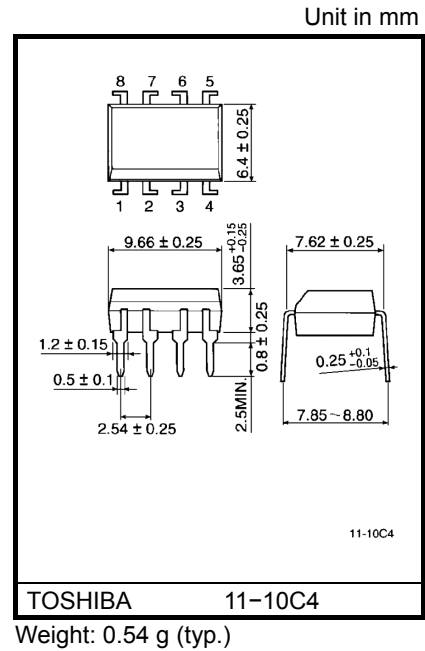

### Pin Configuration (top view)

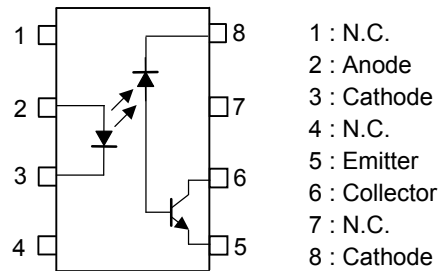

### Schematic

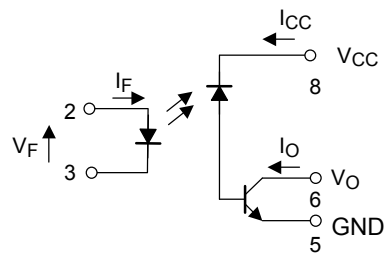

## Current Transfer Ratio

Classification	Current Transfer Ratio (%) (IC/IF)		Marking of Classification
	MIN	MAX	
(None)	10	—	Blank, O, Y
Rank O	19	—	O
Rank Y	35	—	Y

## Absolute Maximum Ratings (Ta = 25°C)

Characteristic		Symbol	Rating	Unit
LED	Forward current (Note 1)	I <sub>F</sub>	25	mA
	Pulse forward current (Note 2)	I <sub>FP</sub>	50	mA
	Peak transient forward current (Note 3)	I <sub>FPT</sub>	1	A
	Reverse voltage	V <sub>R</sub>	5	V
	Diode power dissipation (Note 4)	P <sub>D</sub>	45	mW
Detector	Output current	I <sub>O</sub>	8	mA
	Peak output current	I <sub>OP</sub>	16	mA
	Supply voltage	V <sub>CC</sub>	-0.5~15	V
	Output voltage	V <sub>O</sub>	-0.5~15	V
	Output power dissipation (Note 5)	P <sub>O</sub>	100	mW
Operating temperature range		T <sub>opr</sub>	-55~100	°C
Storage temperature range		T <sub>stg</sub>	-55~125	°C
Lead solder temperature (10s)		T <sub>sol</sub>	260	°C
Isolation voltage (AC, 1min., R.H. = 40~60%) (Note 6)		BV <sub>S</sub>	2500	V <sub>rms</sub>

Note: Using continuously under heavy loads (e.g. the application of high temperature/current/voltage and the significant change in temperature, etc.) may cause this product to decrease in the reliability significantly even if the operating conditions (i.e. operating temperature/current/voltage, etc.) are within the absolute maximum ratings.

Please design the appropriate reliability upon reviewing the Toshiba Semiconductor Reliability Handbook ("Handling Precautions"/"Derating Concept and Methods") and individual reliability data (i.e. reliability test report and estimated failure rate, etc).

(Note 1) Derate 0.8mA above 70°C.

(Note 2) 50% duty cycle, 1ms pulse width.  
Derate 1.6mA / °C above 70°C.

(Note 3) Pulse width 1μs, 300pps.

(Note 4) Derate 0.9mW / °C above 70°C.

(Note 5) Derate 2mW / °C above 70°C.

## Electrical Characteristics (Ta = 25°C)

Characteristic		Symbol	Test condition	Min.	Typ.	Max.	Unit	
LED	Forward voltage	$V_F$	$I_F = 16 \text{ mA}$	1.45	1.65	1.85	V	
	Forward voltage temperature coefficient	$\Delta V_F / \Delta T_a$	$I_F = 16 \text{ mA}$	—	-2	—	mV / °C	
	Reverse current	$I_R$	$V_R = 5 \text{ V}$	—	—	10	$\mu\text{A}$	
	Capacitance between terminal	$C_T$	$V_F = 0, f = 1 \text{ MHz}$	—	60	—	pF	
Detector	High level output current	$I_{OH(1)}$	$I_F = 0 \text{ mA}, V_{CC} = V_O = 5.5 \text{ V}$	—	3	500	nA	
		$I_{OH(2)}$	$I_F = 0 \text{ mA}, V_{CC} = V_O = 15 \text{ V}$	—	—	5	$\mu\text{A}$	
		$I_{OH}$	$I_F = 0 \text{ mA}, V_{CC} = V_O = 15 \text{ V}$ $T_a = 70^\circ\text{C}$	—	—	50	$\mu\text{A}$	
High level supply voltage	$I_{CCH}$	$I_F = 0 \text{ mA}, V_{CC} = 15 \text{ V}$	—	0.01	1	$\mu\text{A}$		
Coupled	Current transfer ratio	$I_O / I_F$	$I_F = 16 \text{ mA}$ $V_{CC} = 4.5 \text{ V}$ $V_O = 0.4 \text{ V}$	$T_a = 25^\circ\text{C}$	10	30	—	%
				Rank : 0	19	30	—	
				Rank : Y	35	50	—	
				$T_a = 0\sim 70^\circ\text{C}$	5	—	—	
		Rank : 0, Y	15	—	—			
	Low level output voltage	$V_{OL}$	$I_F = 16 \text{ mA}, V_{CC} = 4.5 \text{ V}$ $I_O = 1.1 \text{ mA}$ (rank 0: $I_O = 2.4 \text{ mA}$ )	—	—	0.4	V	
Isolation resistance	$R_S$	R.H. = 40~60%, V = 1kV DC (Note 6)	—	$10^{12}$	—	$\Omega$		
Capacitance between input to output	$C_S$	$V = 0, f = 1 \text{ MHz}$	—	0.8	—	pF		

## Switching Characteristics (Ta = 25°C)

Characteristic	Symbol	Test Condition	Min.	Typ.	Max.	Unit
Propagation delay time (H→L)	$t_{pHL}$	$I_F = 0 \rightarrow 16 \text{ mA}, V_{CC} = 5 \text{ V}, R_L = 4.1 \text{ k}\Omega$	—	0.3	0.8	$\mu\text{s}$
		(Note 7) Rank 0: $R_L = 1.9 \text{ k}\Omega$	—	0.5	0.8	
Propagation delay time (L→H)	$t_{pLH}$	$I_F = 16 \rightarrow 0 \text{ mA}, V_{CC} = 5 \text{ V}, R_L = 4.1 \text{ k}\Omega$	—	1.0	2.0	$\mu\text{s}$
		(Note 7) Rank 0: $R_L = 1.9 \text{ k}\Omega$	—	0.6	1.2	
Common mode transient immunity at high output level	$C_{MH}$	$I_F = 0 \text{ mA}, V_{CM} = 200 \text{ V}_{p-p}$ $R_L = 4.1 \text{ k}\Omega$ (rank 0: $R_L = 1.9 \text{ k}\Omega$ ) (Note 8)	—	1500	—	V / $\mu\text{s}$
Common mode transient immunity at low output level	$C_{ML}$	$I_F = 16 \text{ mA}, V_{CM} = 200 \text{ V}_{p-p}$ $R_L = 4.1 \text{ k}\Omega$ (rank 0: $R_L = 1.9 \text{ k}\Omega$ ) (Note 8)	—	-1500	—	V / $\mu\text{s}$

(Note 6) Device considered two-terminal device: Pins 1, 2, 3 and 4 shorted together and pin 5, 6, 7 and 8 shorted together.

(Note 7) Switching time test circuit.

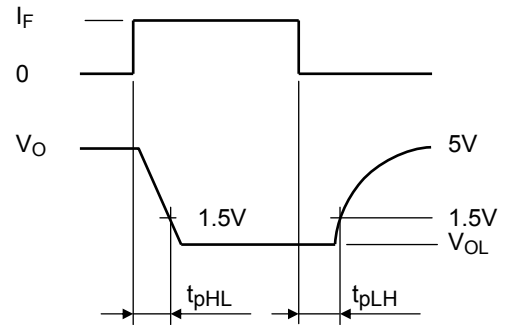
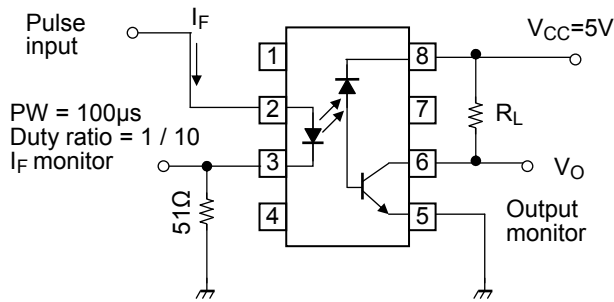

(Note 8) Common mode transient immunity test circuit.

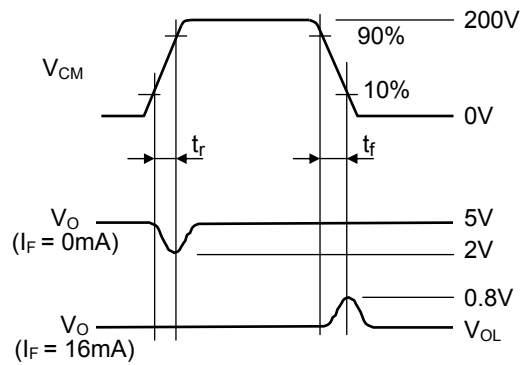
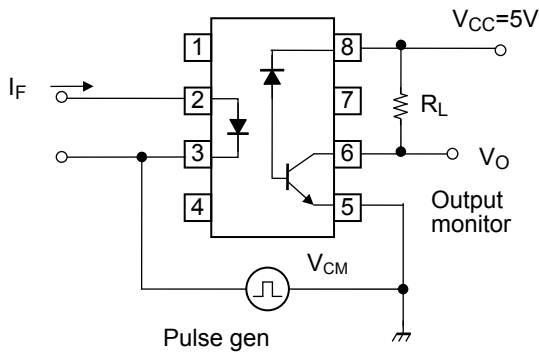

$Z_0=50\Omega$

$$CM_H = \frac{160 (V)}{t_f (\mu s)}, \quad CM_L = \frac{160 (V)}{t_f (\mu s)}$$

(Note 9) Maximum electrostatic discharge voltage for any pins: 100V (C = 200pF, R = 0)

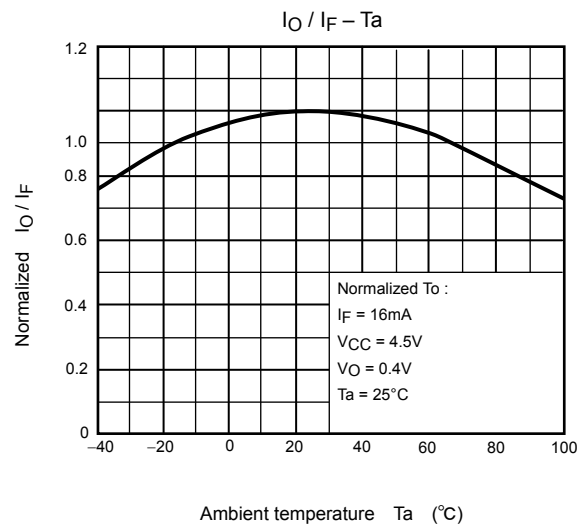
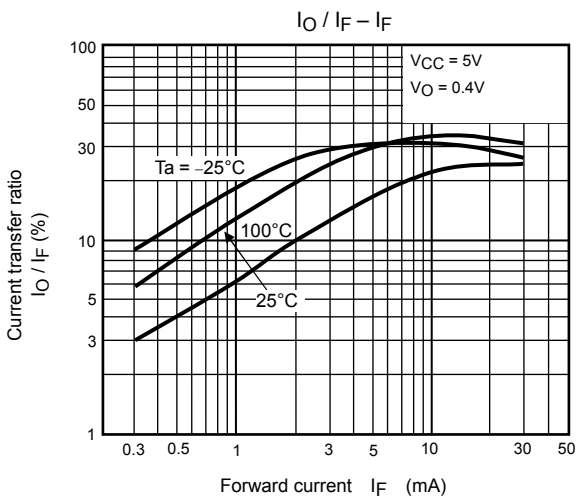
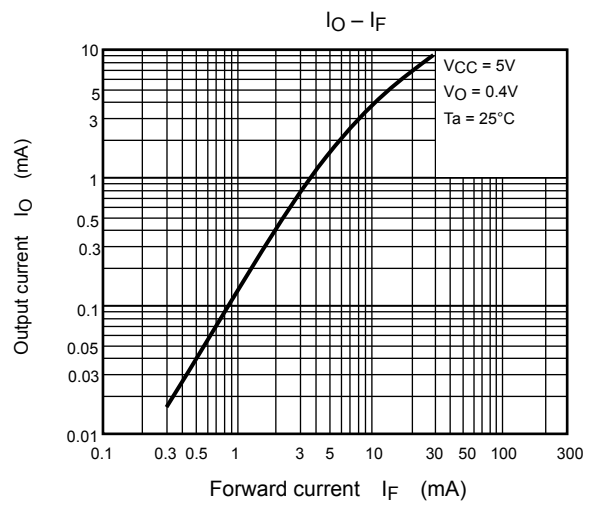
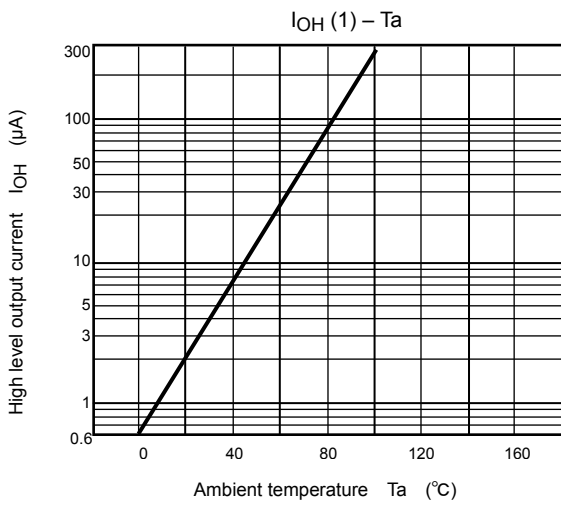
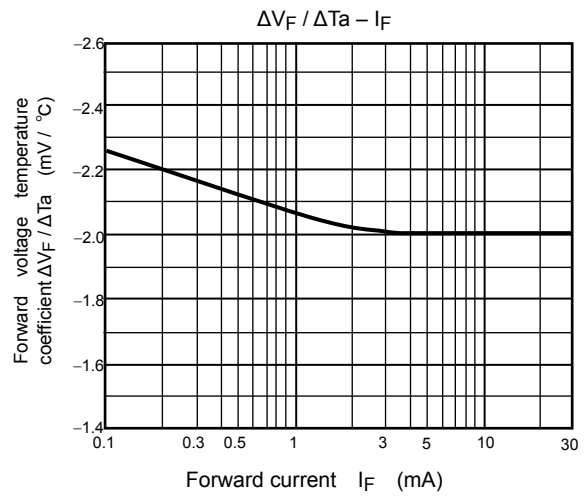
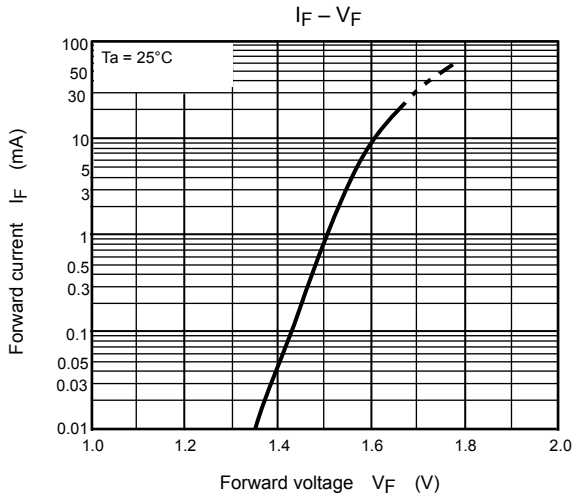

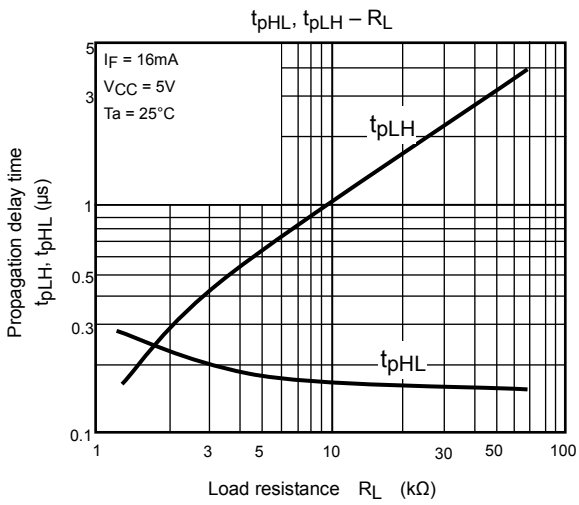
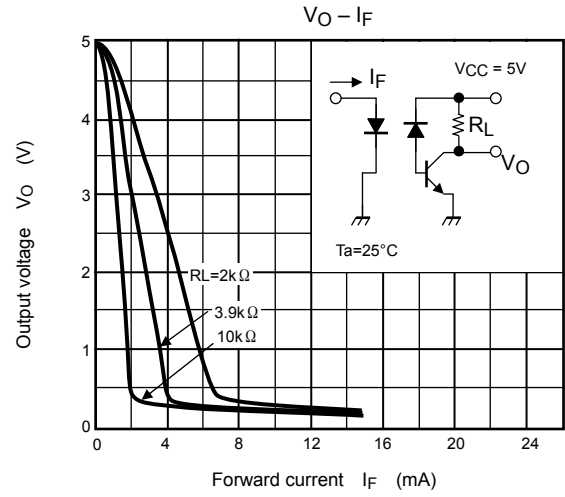
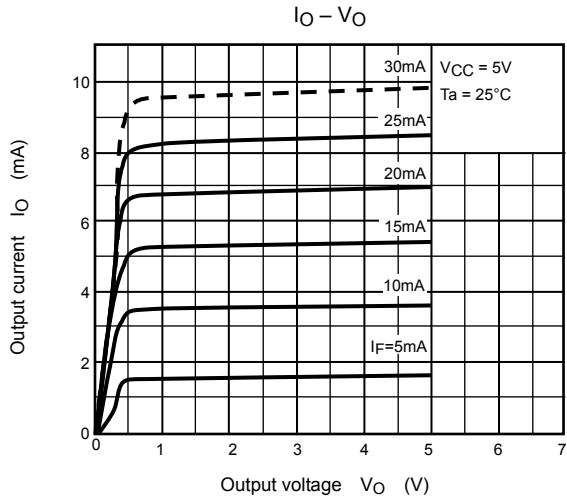

**RESTRICTIONS ON PRODUCT USE**

20070701-EN

- The information contained herein is subject to change without notice.
- TOSHIBA is continually working to improve the quality and reliability of its products. Nevertheless, semiconductor devices in general can malfunction or fail due to their inherent electrical sensitivity and vulnerability to physical stress. It is the responsibility of the buyer, when utilizing TOSHIBA products, to comply with the standards of safety in making a safe design for the entire system, and to avoid situations in which a malfunction or failure of such TOSHIBA products could cause loss of human life, bodily injury or damage to property.  
In developing your designs, please ensure that TOSHIBA products are used within specified operating ranges as set forth in the most recent TOSHIBA products specifications. Also, please keep in mind the precautions and conditions set forth in the "Handling Guide for Semiconductor Devices," or "TOSHIBA Semiconductor Reliability Handbook" etc.
- The TOSHIBA products listed in this document are intended for usage in general electronics applications (computer, personal equipment, office equipment, measuring equipment, industrial robotics, domestic appliances, etc.). These TOSHIBA products are neither intended nor warranted for usage in equipment that requires extraordinarily high quality and/or reliability or a malfunction or failure of which may cause loss of human life or bodily injury ("Unintended Usage"). Unintended Usage include atomic energy control instruments, airplane or spaceship instruments, transportation instruments, traffic signal instruments, combustion control instruments, medical instruments, all types of safety devices, etc.. Unintended Usage of TOSHIBA products listed in this document shall be made at the customer's own risk.
- The products described in this document shall not be used or embedded to any downstream products of which manufacture, use and/or sale are prohibited under any applicable laws and regulations.
- The information contained herein is presented only as a guide for the applications of our products. No responsibility is assumed by TOSHIBA for any infringements of patents or other rights of the third parties which may result from its use. No license is granted by implication or otherwise under any patents or other rights of TOSHIBA or the third parties.
- GaAs(Gallium Arsenide) is used in this product. The dust or vapor is harmful to the human body. Do not break, cut, crush or dissolve chemically.
- Please contact your sales representative for product-by-product details in this document regarding RoHS compatibility. Please use these products in this document in compliance with all applicable laws and regulations that regulate the inclusion or use of controlled substances. Toshiba assumes no liability for damage or losses occurring as a result of noncompliance with applicable laws and regulations.