

TLP5214A

Isolated IGBT/Power MOSFET gate drive
 AC and brushless DC motor drives
 Industrial Inverters and Uninterruptible Power Supply (UPS)

The TLP5214A is a highly integrated 4.0 A output current IGBT gate drive photocoupler housed in a long creepage and clearance SO16L package. The TLP5214A, a smart gate driver photocoupler, includes functions of IGBT desaturation detection, isolated fault status feedback, soft IGBT turn-off, active Miller clamping and under voltage lockout (UVLO). Moreover, this photocoupler has features of the desaturation leading edge blanking time, filtering time, and optimisation of the soft-shutdown performance for secure operation of applications. This photocoupler is suitable for driving IGBT and power MOSFET used in inverter applications. The TLP5214A consists two infrared LEDs and two high-gain and high-speed ICs. They realize high current, high-speed output control and output fault status feedback.

- Peak output current: ± 4.0 A (max)
- Guaranteed performance over temperature: -40 to 110 °C
- Supply current: 3.8 mA (max)
- Power supply voltage: 15 V to 30 V
- Threshold input current: 6 mA (max)
- Propagation delay time: 150 ns (max)
- DESAT leading edge blanking time: 1.1 μ s (typ.)
- Common-mode transient immunity: ± 35 kV/ μ s (min)
- Isolation voltage: 5000 Vrms (min)
- UL-recognized : UL 1577, File No.E67349
- cUL-recognized :CSA Component Acceptance Service No. 5A, File No.E67349
- VDE approved: EN 60747-5-5, EN 62368-1 (Note 1)

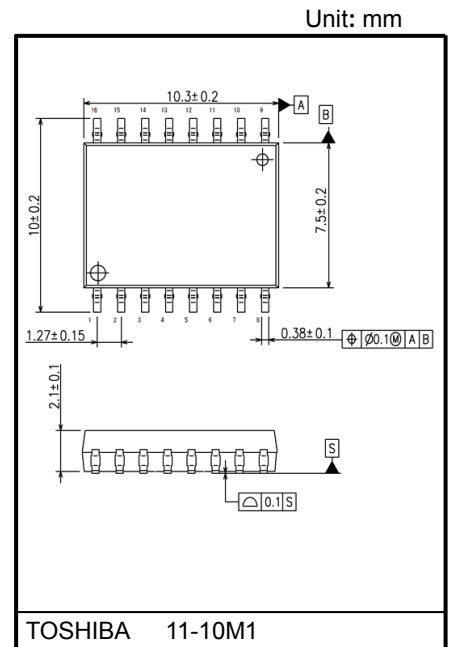

Weight: 0.37 g (typ.)

- Construction mechanical rating

	SO16L
Height	2.3 mm (max)
Creepage Distance	8.0 mm (min)
Clearance	8.0 mm (min)
Insulation Thickness	0.4 mm (min)

Note 1: When a VDE approved type is needed, please designate the **Option(D4)**.

Truth Table

I _F	UVLO (V _{CC2} -V _E)	DESAT (14Pin DESAT Terminal Input)	FAULT (3Pin FAULT Terminal Output)	V _O
OFF	Not Active (> V _{UVLO} ⁺)	Not Active	High	Low
ON	Not Active (> V _{UVLO} ⁺)	Low (< V _{DESAT} th)	High	High
ON	Not Active (> V _{UVLO} ⁺)	High (> V _{DESAT} th)	Low (FAULT)	Low
ON	Active (< V _{UVLO} ⁻)	Not Active	High	Low
OFF	Active (< V _{UVLO} ⁻)	Not Active	High	Low

Start of commercial production
 2017-03

Pin Configuration (top view)

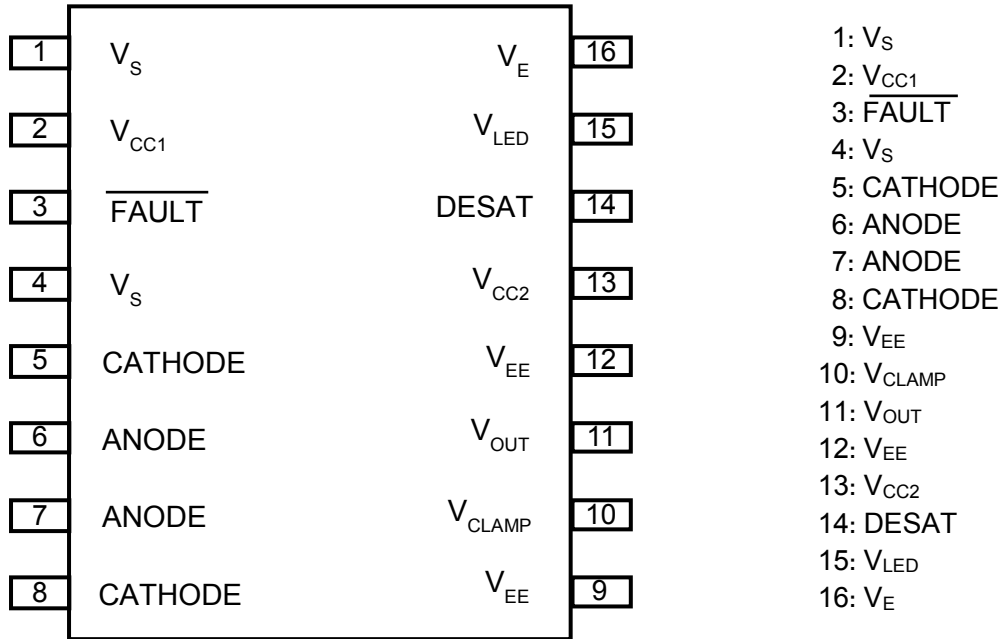

Internal Circuit

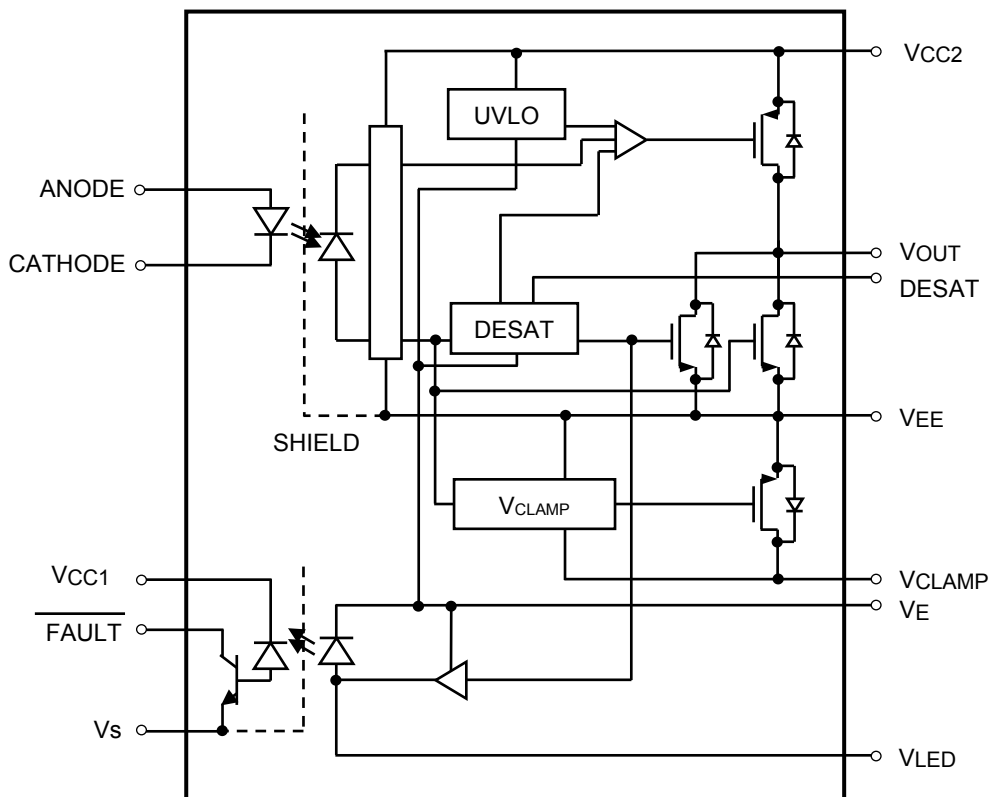

Note: A 1- μ F bypass capacitor must be connected between pins 9 and 13, pins 13 and 16.

Absolute Maximum Ratings (Note) (Unless otherwise specified, Ta = 25 °C)

	Characteristics		Symbol	Rating	Unit
LED	Input forward current		I_F	25	mA
	Input forward current derating (Ta ≥ 95°C)		$\Delta I_F / \Delta T_a$	-1	mA/°C
	Peak transient input forward current (Note 1)		I_{FPT}	1	A
	Peak transient input forward current derating (Ta ≥ 95°C)		$\Delta I_{FPT} / \Delta T_a$	-25	mA/°C
	Reverse input voltage		V_R	6	V
	Input power dissipation		P_D	145	mW
	Input power dissipation derating (Ta ≥ 95°C)		$\Delta P_D / \Delta T_a$	-5.0	mW/°C
Detector	Positive input supply voltage		V_{CC1}	-0.5 to 7	V
	"H" peak output current	Ta = -40 to 110 °C (Note 2)	I_{OPH}	-4.0	A
	"L" peak output current		I_{OPL}	+4.0	A
	\overline{FAULT} output current		$I_{\overline{FAULT}}$	8	mA
	\overline{FAULT} pin voltage		$V_{\overline{FAULT}}$	-0.5 to V_{CC1}	V
	Total output supply voltage		$(V_{CC2} - V_{EE})$	-0.5 to 35	V
	Negative output supply voltage		$(V_E - V_{EE})$	-0.5 to 15	V
	Positive output supply voltage		$(V_{CC2} - V_E)$	-0.5 to 35 - $(V_E - V_{EE})$	V
	Output voltage		V_O	-0.5 to V_{CC2}	V
	Peak clamping sinking current		I_{Clamp}	1.7	A
	Miller clamping pin voltage		V_{Clamp}	-0.5 to V_{CC2}	V
	DESAT voltage		V_{DESAT}	V_E to $V_E + 10$	V
	Output power dissipation		P_O	410	mW
	Output power dissipation derating (Ta ≥ 95°C)		$\Delta P_O / \Delta T_a$	-14.0	mW/°C
	Common	Operating temperature range		T_{opr}	-40 to 110
Storage temperature range		T_{stg}	-55 to 125	°C	
Lead soldering temperature (10 s) (Note 3)		T_{sol}	260	°C	
Isolation voltage (AC, 60 s, R.H. ≤ 60%) (Note 4)		BV_S	5000	V _{rms}	

Note: Using continuously under heavy loads (e.g. the application of high temperature/current/voltage and the significant change in temperature, etc.) may cause this product to decrease in the reliability significantly even if the operating conditions (i.e. operating temperature/current/voltage, etc.) are within the absolute maximum ratings.

Please design the appropriate reliability upon reviewing the Toshiba Semiconductor Reliability Handbook ("Handling Precautions"/"Derating Concept and Methods") and individual reliability data (i.e. reliability test report and estimated failure rate, etc).

Note: A ceramic capacitor (1 μF) should be connected between pins 9 and 13, pins 13 and 16 to stabilize the operation of the high gain linear amplifier. Furthermore, in case $V_E - V_{EE} > 0$ V, a bypass capacitor, which has good high frequency characteristic, a ceramic capacitor (1 μF) should be connected between pins 9 and 16. Failure to provide the bypassing may impair the switching property. The total lead length between capacitor and coupler should not exceed 1 cm.

Note 1: Pulse width $P_W \leq 1 \mu s$, 300 pps

Note 2: Exponential waveform pulse width $P_W \leq 0.2 \mu s$, $f \leq 15$ kHz, $V_{CC2} = 15$ V

Note 3: For the effective lead soldering area.

Note 4: This device considered a two-terminal device: All pins on the LED side are shorted together, and all pin on the photodetector side are shorted together.

Recommended Operating Conditions (Note)

Characteristics	Symbol	Min	Typ.	Max	Unit
Total output supply voltage (Note 1)	(V _{CC2} -V _{EE})	15	-	30	V
Negative output supply voltage	(V _E -V _{EE})	0	-	15	V
Positive output supply voltage	(V _{CC2} -V _E)	15	-	30 - (V _E -V _{EE})	V
Positive input supply voltage	V _{CC1}	3.3	-	5.5	V
Input on-state current (Note 2)	I _{F(ON)}	7.5	-	10	mA
Input off-state voltage	V _{F(OFF)}	0	-	0.8	V
Operating frequency (Note 3)	f	-	-	50	kHz

Note: Recommended operating conditions are given as a design guideline to obtain expected performance of the device. Additionally, each item is an independent guideline respectively. In developing designs using this product, please confirm specified characteristics shown in this document.

Note 1: If the V_{CC2} rise slope is sharp, an internal circuit might not operate with stability. Please design the V_{CC2} rise slope under 3.0 V / μs.

Note 2: Input signal rise time (fall time) ≤ 0.5 μs.

Note 3: Exponential waveform. I_{OPH} ≥ -4.0 A (≤ 90 ns), I_{OPL} ≤ 4.0 A (≤ 90 ns), Ta = 110 °C

Electrical Characteristics (Note)

(Unless otherwise specified, Ta = -40 to 110 °C, VCC2 - VEE = 15 to 30 V, VE - VEE = 0 V)

Characteristics	Symbol	Test Circuit	Test Condition	Min	Typ.	Max	Unit
Input forward voltage	V _F	—	I _F = 10 mA, Ta = 25 °C	1.4	-	1.7	V
Input reverse current	I _R	—	V _R = 5 V	-	-	10	μA
Input capacitance	C _t	—	V = 0 V, f = 1 MHz, Ta = 25 °C	-	95	-	pF
FAULT low level output voltage	V _{FAULTL}	—	I _{FAULT} = 1.1 mA, V _{CC1} = 5.5 V	-	0.2	0.4	V
			I _{FAULT} = 1.1 mA, V _{CC1} = 3.3 V	-	0.2	0.4	
FAULT high level output current	I _{FAULTH}	—	V _{FAULT} = 5.5 V, V _{CC1} = 5.5 V, Ta = 25 °C	-	-	0.5	μA
			V _{FAULT} = 5.5 V, V _{CC1} = 3.3 V, Ta = 25 °C	-	-	0.3	
High level output current (Note 1)	I _{OPH}	1	V _O = V _{CC2} - 4 V	-	-4.0	-1.2	A
			V _O = V _{CC2} - 7 V	-	-6.5	-3.0	
Low level output current (Note 1)	I _{OPL}	2	V _O = V _{EE} + 2.5 V	1.2	3.5	-	
			V _O = V _{EE} + 7 V	3	5.5	-	
Low level output current during fault condition	I _{OLF}	—	V _O - V _{EE} = 14 V	90	150	230	mA
High level output voltage	V _{OH}	3	I _O = -100 mA	V _{CC2} -0.3	V _{CC2} -0.1	-	V
Low level output voltage	V _{OL}	4	I _O = 100 mA	-	0.1	0.2	
Clamp pin threshold voltage	V _{tClamp}	—	—	-	2.5	-	
Clamp low level sinking current	I _{CL}	—	V _O = V _{EE} + 2.5 V	0.56	1.8	-	A
High level supply current	I _{CC2H}	5	I _O = 0 mA	-	2.4	3.8	mA
Low level supply current	I _{CC2L}	6	I _O = 0 mA	-	2.3	3.8	
Blanking capacitor charging current	I _{CHG}	7	V _{DESAT} = 2 V	-0.33	-0.24	-0.13	
Blanking capacitor discharge current	I _{DSCHG}	8	V _{DESAT} = 7 V	10	49	-	
DESAT threshold voltage	V _{DESAT}	—	V _{CC2} - V _E > V _{UVLO-}	5.9	6.5	7.5	V
UVLO threshold voltage	V _{UVLO+}	9	V _O > 5 V	10.5	11.6	13.5	
	V _{UVLO-}	9	V _O < 5 V	9.2	10.3	11.1	
UVLO hysteresis	V _{UVLOHYS}	—	—	-	1.3	-	
Threshold input current (L/H)	I _{FLH}	10	V _{CC2} = 30 V, V _O < 5 V	-	2.6	6	mA
Threshold input voltage (H/L)	V _{FHL}	—	V _{CC2} = 30 V, V _O > 5 V	0.8	-	-	V

Note: All typical values are at Ta = 25 °C

Note: This product is more sensitive than conventional products to electrostatic discharge ESD owing to its low power consumption design.

It is therefore all the more necessary to observe general precautions regarding ESD when handling this component.

Note 1: I_O application time ≤ 50 μs, 1 pulse

Isolation Characteristics (Note) (Ta = 25 °C)

Characteristic	Symbol	Test Condition	Min	Typ.	Max	Unit
Capacitance input to output	C _S	V _S = 0 V, f = 1 MHz	-	1.0	-	pF
Isolation resistance	R _S	R.H. ≤ 60 %, V _S = 500 V	10 ¹²	10 ¹⁴	-	Ω
Isolation voltage	BV _S	AC, 60 s	5000	-		V _{rms}

Note: This device considered a two-terminal device: All pins on the LED side are shorted together, and all pin on the photodetector side are shorted together.

Switching Characteristics (Note)

(Unless otherwise specified, $T_a = -40$ to 110 °C, $V_{CC2} - V_{EE} = 15$ to 30 V, $V_E - V_{EE} = 0$ V)

Characteristics		Symbol	Test Circuit	Test Condition	Min	Typ.	Max	Unit		
Propagation delay time (Note 1)	L → H	t_{pLH}	11	$R_g = 10 \Omega$, $C_g = 25$ nF, $V_{CC2} = 30$ V	$I_F = 0 \rightarrow 10$ mA	50	85	150	ns	
	H → L	t_{pHL}			$I_F = 10 \rightarrow 0$ mA	50	90	150		
Output rise time (10-90 %) (Note 1)		t_r			$I_F = 0 \rightarrow 10$ mA	-	32	-		
Output fall time (90-10 %) (Note 1)		t_f			$I_F = 10 \rightarrow 0$ mA	-	18	-		
Pulse with distortion (Note 1)		$ t_{pHL} - t_{pLH} $			$I_F = 0 \leftrightarrow 10$ mA	-	-	50		
Propagation delay skew (Note 1) (device to device) (Note 2)		t_{psk}			$I_F = 0 \leftrightarrow 10$ mA	-80	-	80		
DESAT sense to 90% delay		$t_{DESAT(90\%)}$	12	$C_{DESAT} = 100$ pF, $R_g = 10 \Omega$, $V_{CC2} = 30$ V, $R_F = 2.1$ k Ω , $V_{CC1} = 5$ V	$C_g = 25$ nF	-	230	500	μ s	
DESAT sense to 10% delay		$t_{DESAT(10\%)}$			$C_g = 25$ nF	-	7.0	8.5		
					$C_g = 10$ nF	-	2.5	3.5		
DESAT leading edge blanking time		$t_{DESAT(LEB)}$					-	1.1	-	ns
DESAT filter time		$t_{DESAT(FILTER)}$					-	90	-	
DESAT sense to low level FAULT signal delay		$t_{DESAT(FAULT)}$					-	350	550	ns
DESAT sense to low propagation delay		$t_{DESAT(LOW)}$					-	200	-	
DESAT input mute		$t_{DESAT(MUTE)}$			7	20	-	μ s		
RESET to high level FAULT signal delay		$t_{RESET(FAULT)}$		$C_{DESAT} = 100$ pF, $R_g = 10 \Omega$, $V_{CC2} = 30$ V, $R_F = 2.1$ k Ω , $V_{CC1} = 5.5$ V	0.2	0.6	2			
High-level Common-mode transient immunity (Note 3)		CM_H	13 to 16	$T_a = 25$ °C, $R_g = 10 \Omega$, $C_g = 25$ nF, $V_{CC2} = 30$ V, $R_F = 2.1$ k Ω , $C_F = 15$ pF, $V_{CM} = 1500$ V _{p-p}	$V_O(\min) = 26$ V, $V_{FAULT(\min)} = 2$ V	± 35	-	-	kV/ μ s	
Low-level Common-mode transient immunity (Note 4)		CM_L			$V_O(\max) = 1$ V, $V_{FAULT(\max)} = 0.8$ V	± 35	-	-		

Note: All typical values are at $T_a = 25$ °C.

Note 1: Input signal ($f = 10$ kHz, duty = 50%, $t_r = t_f = 5$ ns or less)

C_L is approximately 15 pF which includes probe and stray wiring capacitance.

Note 2: The propagation delay skew, t_{psk} , is equal to the magnitude of the worst-case difference in t_{pHL} and/or t_{pLH} that will be seen between units at the same given conditions (supply voltage, input current, temperature, etc).

Note 3: CM_H is the maximum rate of fall of the common mode voltage that can sustained with the output voltage in the logic high state ($V_O > 26$ V or $V_{FAULT} > 2$ V).

Note 4: CM_L is the maximum rate of rise of the common mode voltage that can sustained with the output voltage in the logic low state ($V_O < 1$ V or $V_{FAULT} < 0.8$ V).

Test Circuit

Test Circuit 1: IOPH

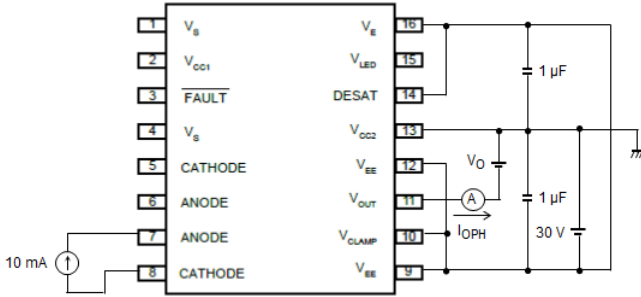

Test Circuit 2: IOPL

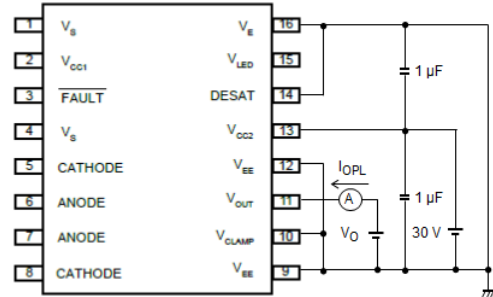

Test Circuit 3: VOH

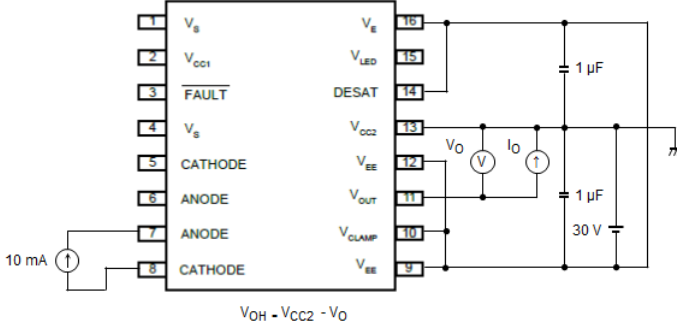

Test Circuit 4: VOL

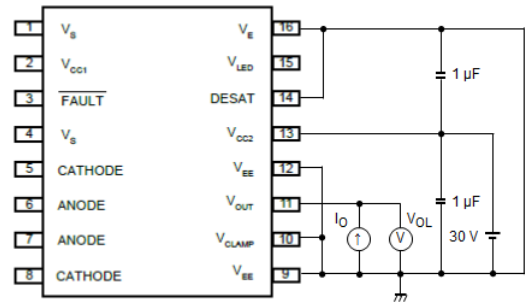

Test Circuit 5: ICC2H

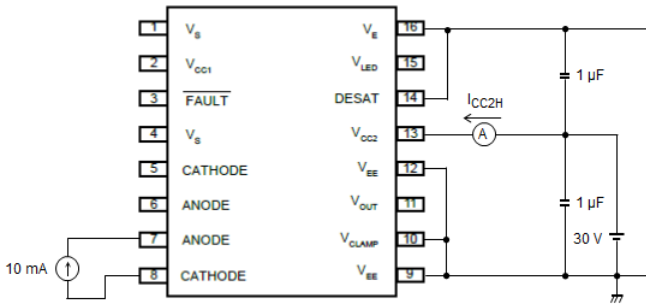

Test Circuit 6: ICC2L

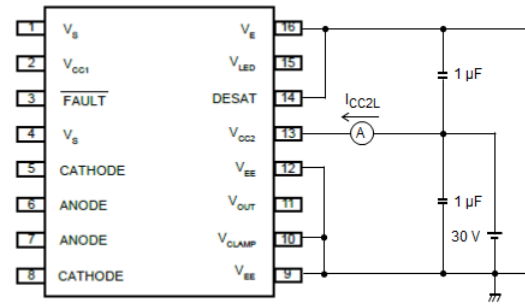

Test Circuit 7: I_{CHG}

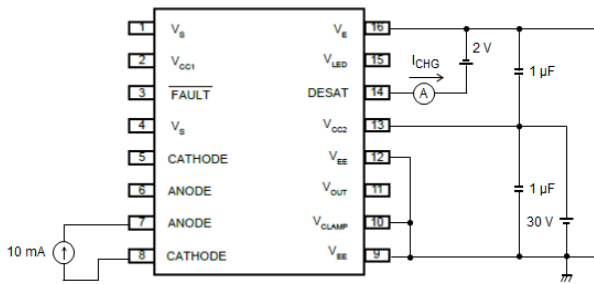

Test Circuit 8: I_{DSCHG}

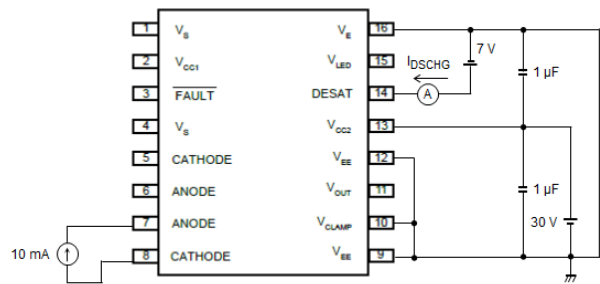

Test Circuit 9: V_{VULO}

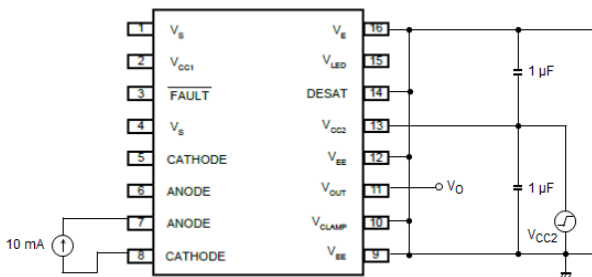

Test Circuit 10: I_{FLH}

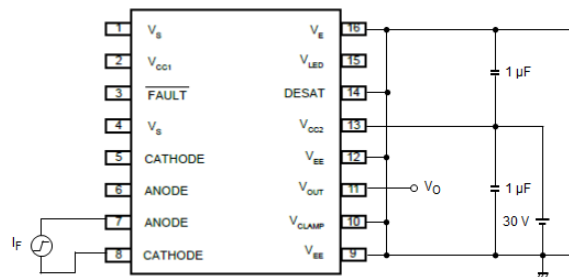

Test Circuit 11: t_{pLH}, t_{pHL}, t_r, t_f, | t_{pHL}-t_{pLH} |

I_F = 10 mA (P.G.)

(f = 10 kHz, duty = 50%, rise / fall time 5 ns or less)

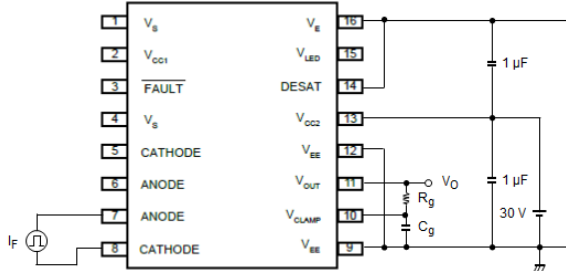

P.G.: Pulse generator

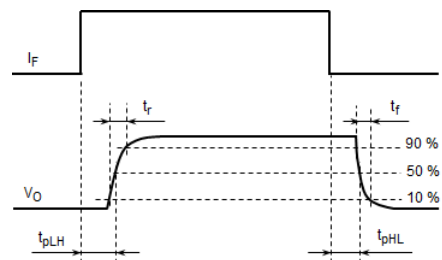

Test Circuit 12: t_{DESAT(90%)}, t_{DESAT(10%)}, t_{DESAT(LEB)}, t_{DESAT(FILTER)}, t_{DESAT(FAULT)}, t_{DESAT(Low)}, t_{DESAT(MUTE)}, t_{RESET(FAULT)}

I_F = 10 mA (P.G.)

(f = 10 kHz, duty = 50%, rise / fall time 5 ns or less)

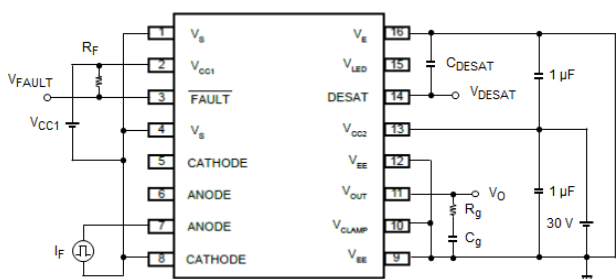

P.G.: Pulse generator

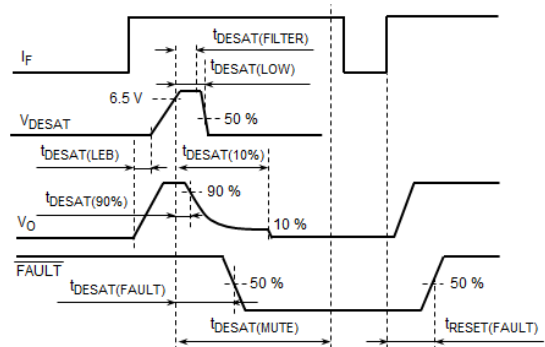

Test Circuit 13: CMR_LED1 ON

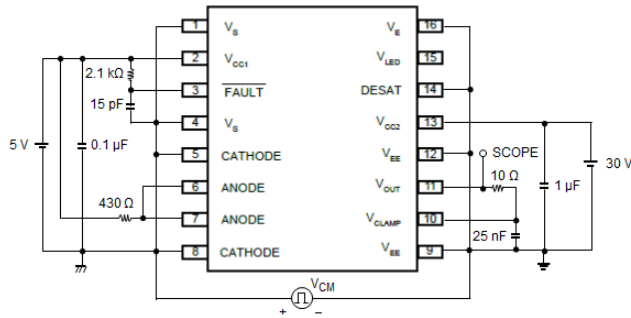

Test Circuit 14: CMR_LED1 OFF

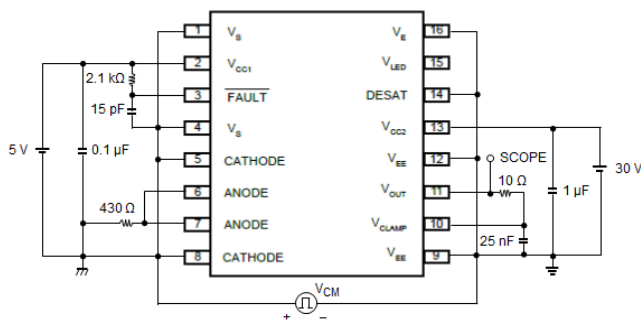

Test Circuit 15: CMR_LED2 ON

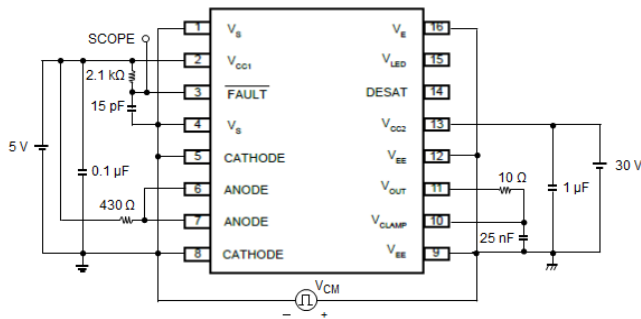

Test Circuit 16: CMR_LED2 OFF

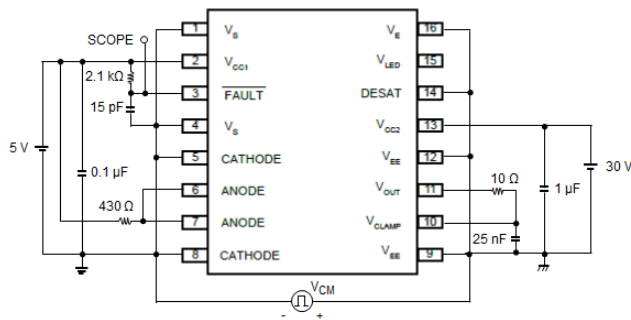

Characteristics Curves (Note)

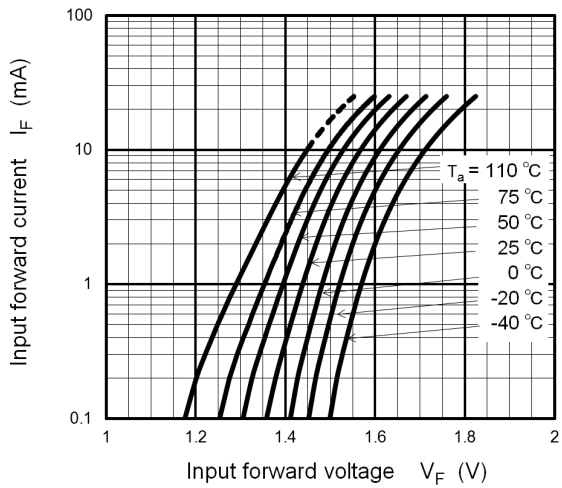

$I_F - V_F$

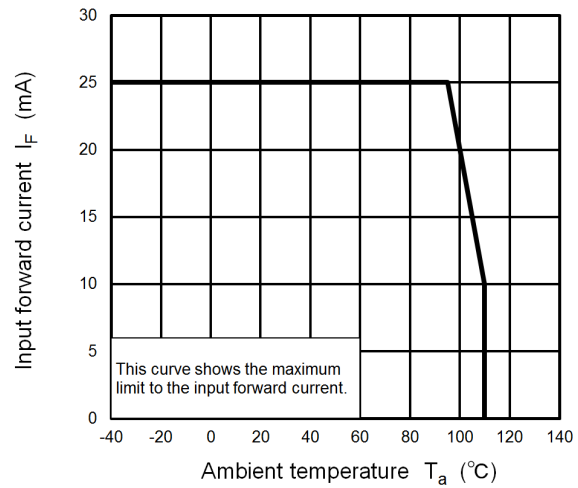

$I_F - T_a$

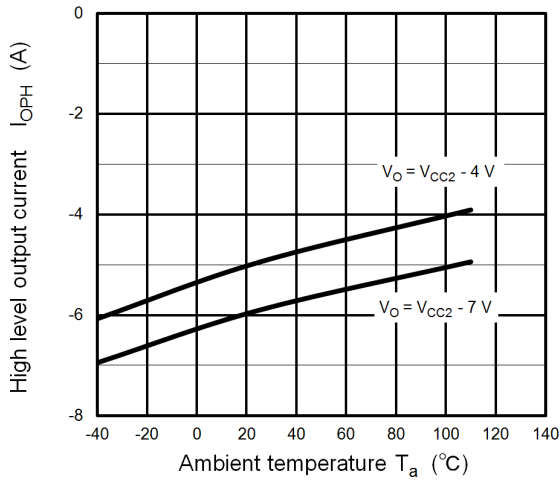

$I_{OPH} - T_a$

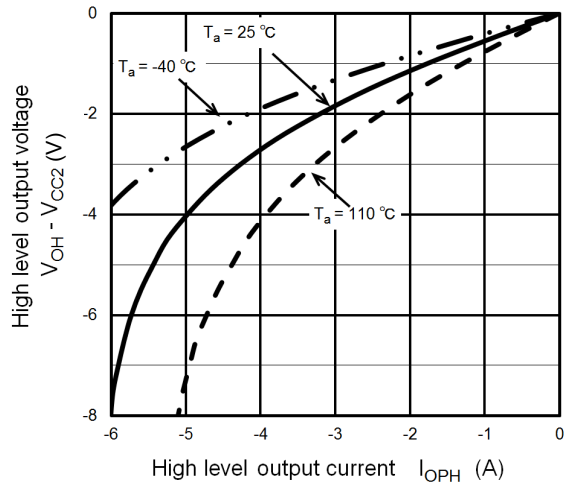

$(V_{OH} - V_{CC2}) - I_{OPH}$

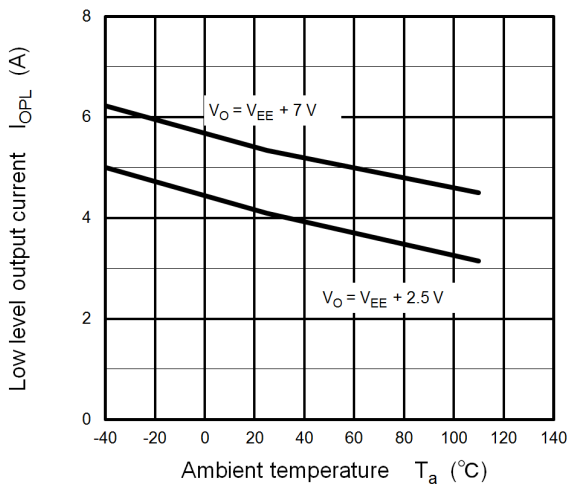

$I_{OPL} - T_a$

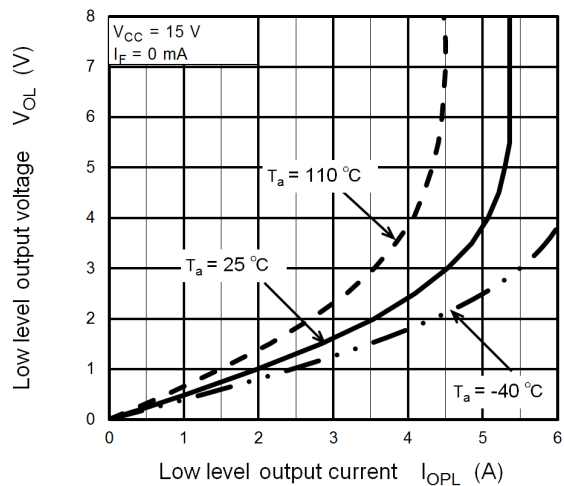

$V_{OL} - I_{OPL}$

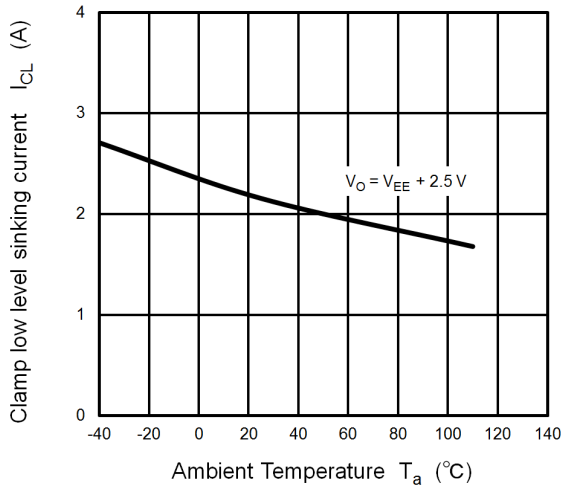

$I_{CL} - T_a$

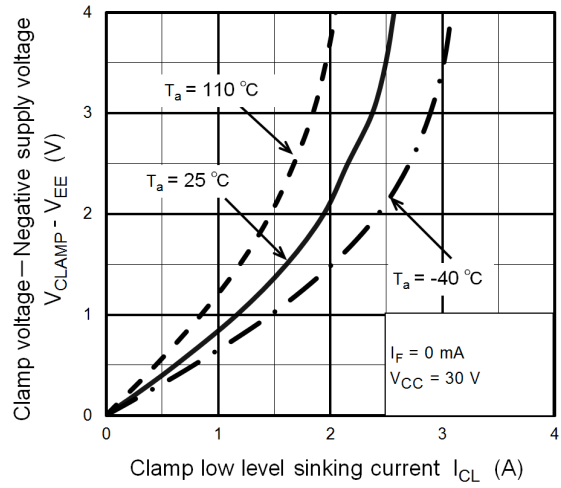

$(V_{CLAMP} - V_{EE}) - I_{CL}$

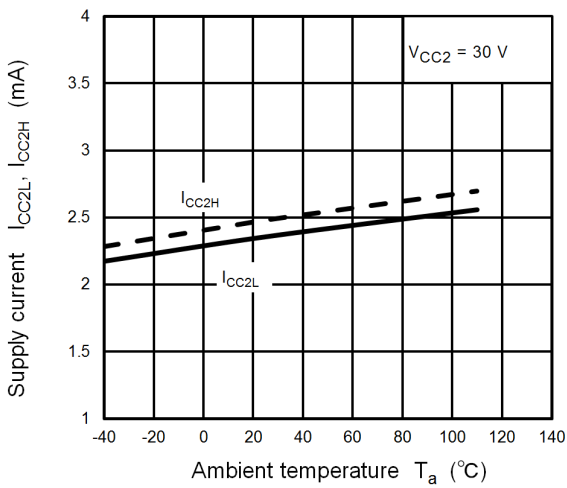

$I_{CC2L}, I_{CC2H} - T_a$

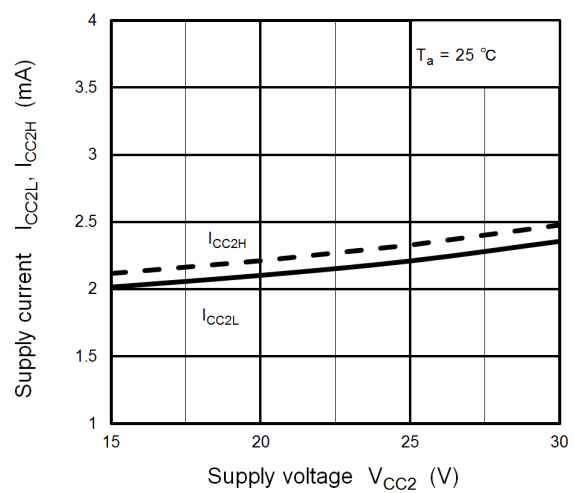

$I_{CC2L}, I_{CC2H} - V_{CC2}$

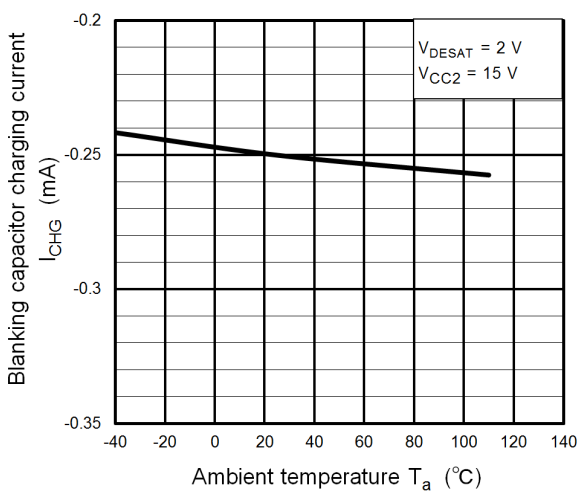

$I_{CHG} - T_a$

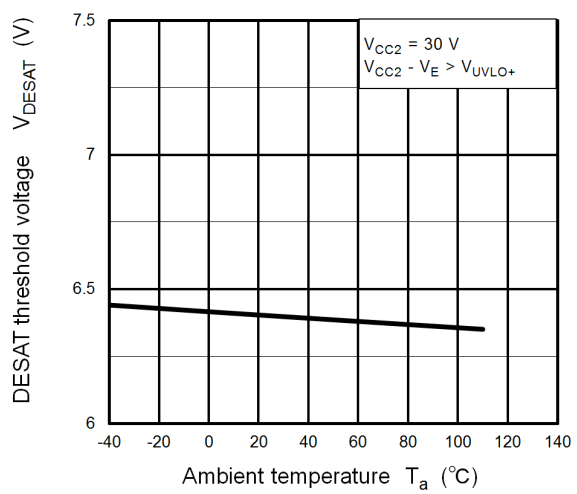

$V_{DESAT} - T_a$

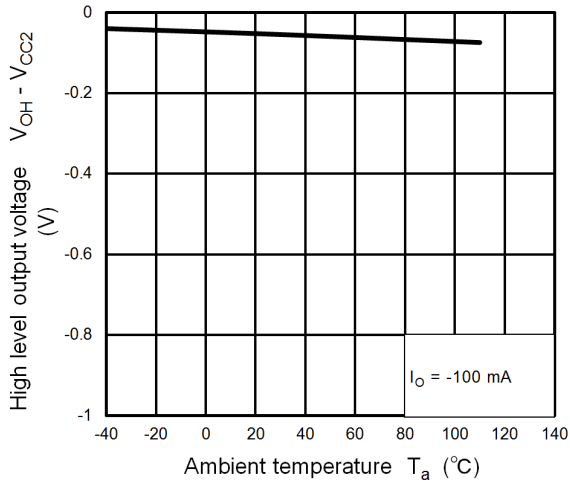

$(V_{OH} - V_{CC2}) - T_a$

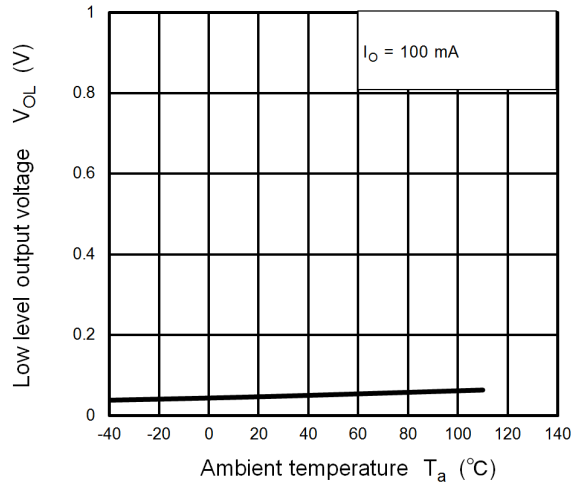

$V_{OL} - T_a$

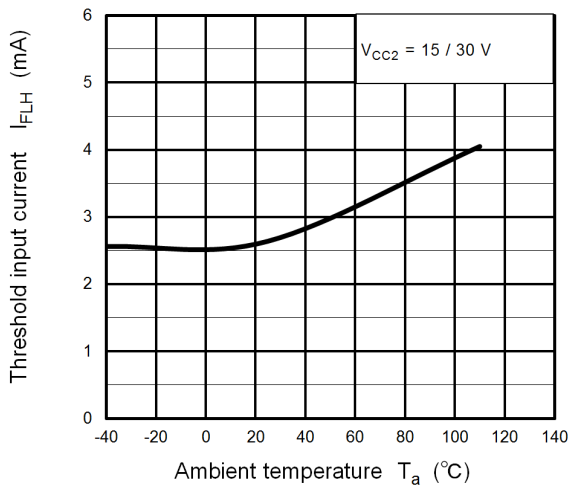

$I_{FLH} - T_a$

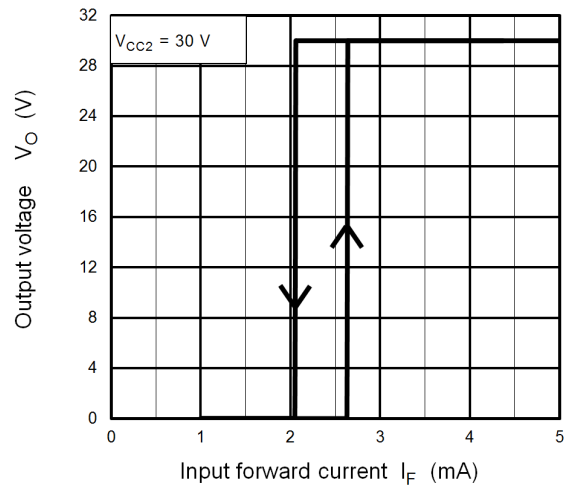

$V_O - I_F$

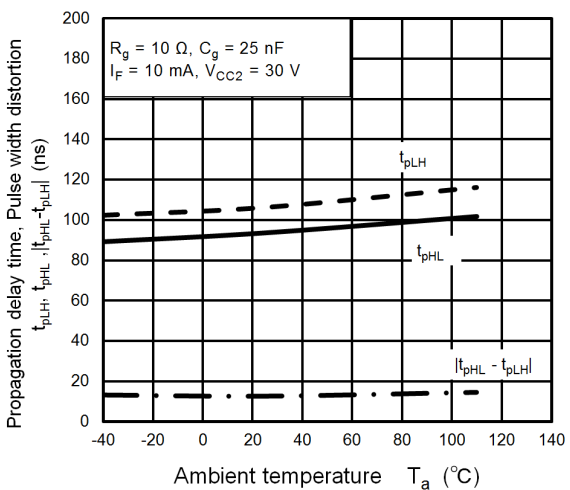

$t_{pHL}, t_{pLH}, |t_{pHL} - t_{pLH}| - T_a$

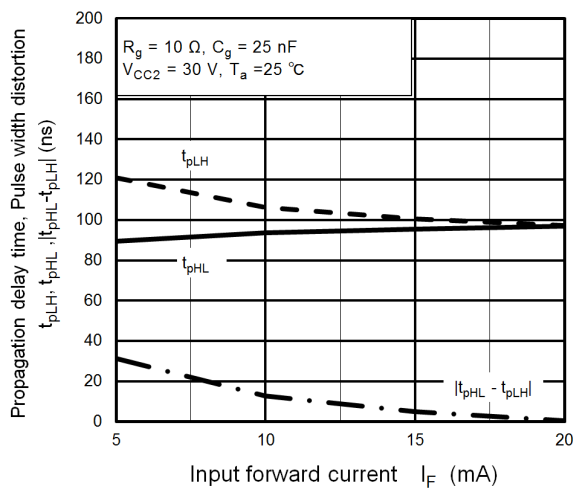

$t_{pHL}, t_{pLH}, |t_{pHL} - t_{pLH}| - I_F$

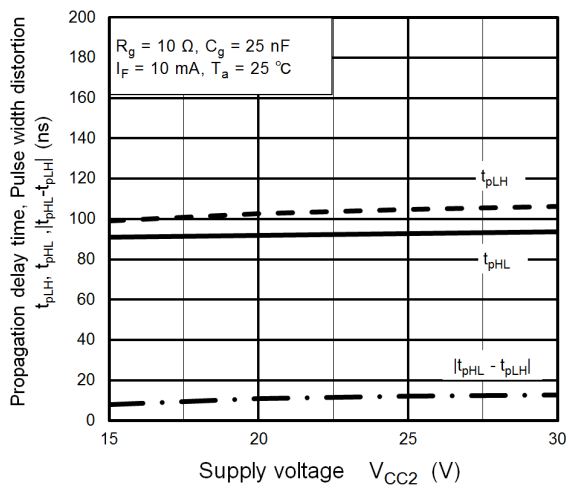

t_{pHL} , t_{pLH} , $|t_{pHL} - t_{pLH}| - V_{CC2}$

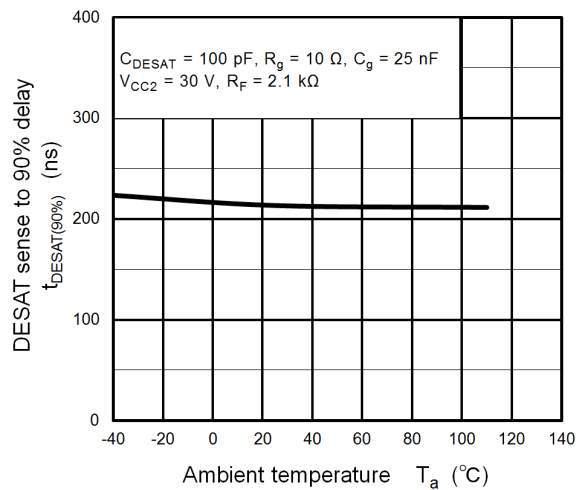

$t_{DESAT(90\%)} - T_a$

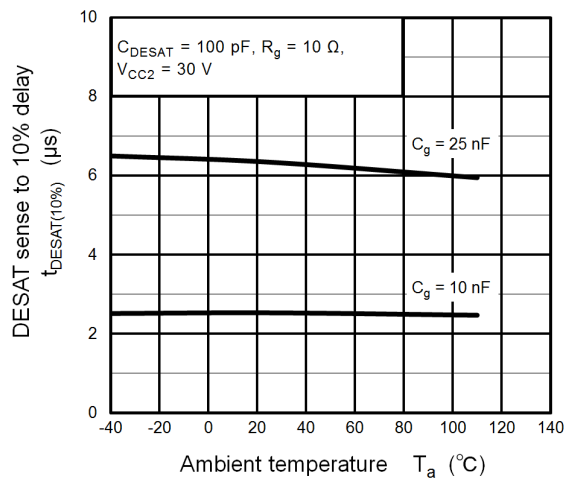

$t_{DESAT(10\%)} - T_a$

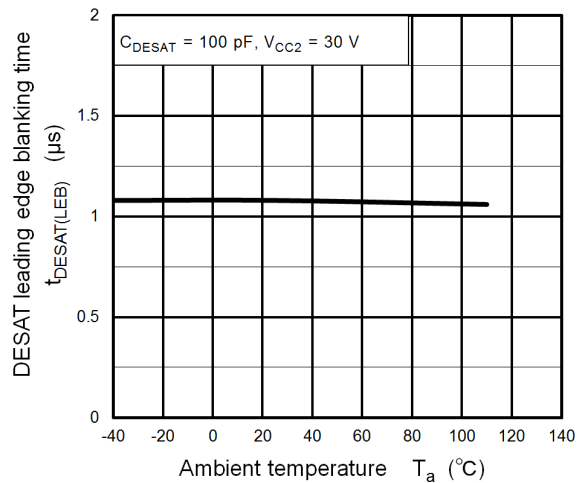

$t_{DESAT(LEB)} - T_a$

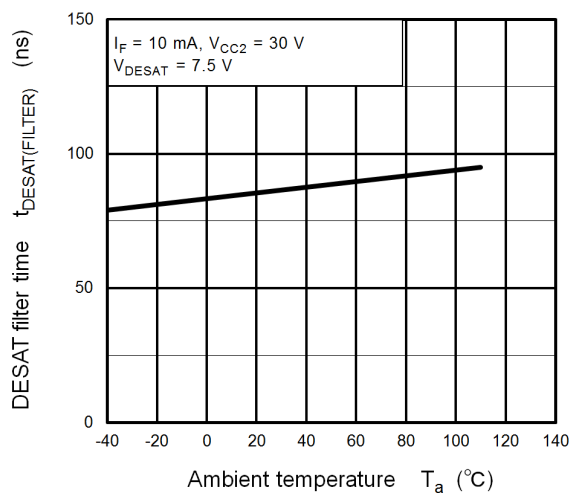

$t_{DESAT(FILTER)} - T_a$

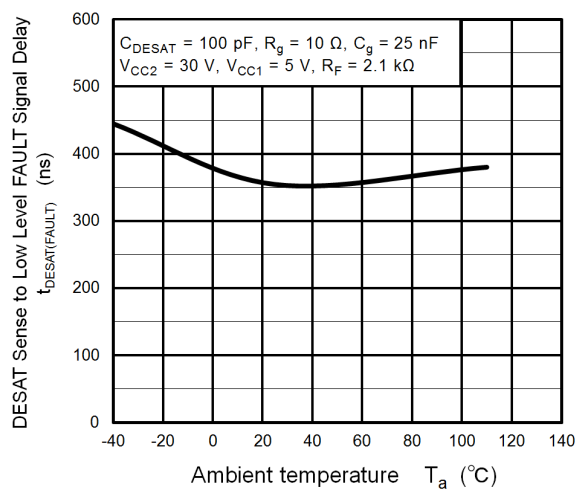

$t_{DESAT(FAULT)} - T_a$

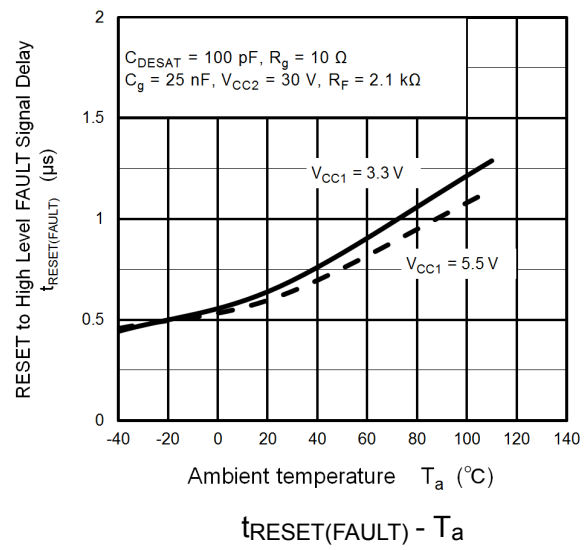
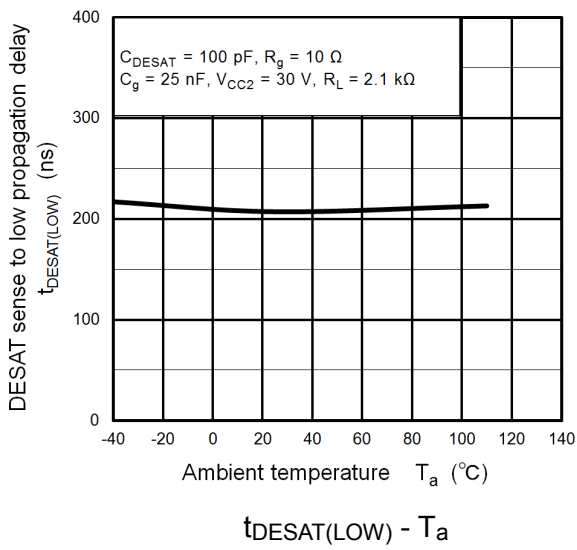

Note: The above characteristics curves are presented for reference only and not guaranteed by production test, unless otherwise noted.

Soldering and Storage

(1) Precautions for Soldering

The soldering temperature should be controlled as closely as possible to the conditions shown below, irrespective of whether a soldering iron or a reflow soldering method is used.

- When using soldering reflow

The soldering temperature profile is based on the package surface temperature.

(See the figure shown below, which is based on the package surface temperature.)

Reflow soldering must be performed once or twice.

The mounting should be complicated with the interval from the first to the last mountings being 2 weeks.

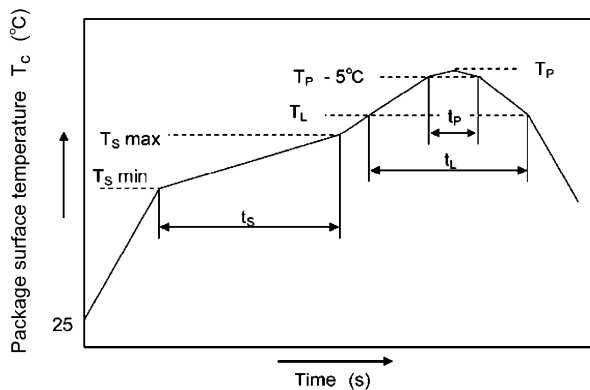

	Symbol	Min	Max	Unit
Preheat temperature	T_s	150	200	°C
Preheat time	t_s	60	120	s
Ramp-up rate (T_L to T_P)			3	°C/s
Liquidus temperature	T_L	217		°C
Time above T_L	t_L	60	150	s
Peak temperature	T_P		260	°C
Time during which T_c is between ($T_P - 5$) and T_P	t_p		30	s
Ramp-down rate (T_P to T_L)			6	°C/s

An example of a temperature profile when lead(Pb)-free solder is used

- When using soldering flow

Preheat the device at a temperature of 150 °C (package surface temperature) for 60 to 150 seconds.

Mounting condition of 260 °C within 10 seconds is recommended.

Flow soldering must be performed once.

- When using soldering iron

Complete soldering within 10 seconds for lead temperature not exceeding 260 °C or within 3 seconds not exceeding 350 °C.

Heating by soldering iron must be done only once per lead.

(2) Precautions for General Storage

- Avoid storage locations where devices may be exposed to moisture or direct sunlight.
- Follow the precautions printed on the packing label of the device for transportation and storage.
- Keep the storage location temperature and humidity within a range of 5 °C to 35 °C and 45 % to 75 %.
- Do not store the products in locations with poisonous gases (especially corrosive gases) or in dusty conditions.
- Store the products in locations with minimal temperature fluctuations. Rapid temperature changes during storage can cause condensation, resulting in lead oxidation or corrosion, which will deteriorate the solderability of the leads.
- When restoring devices after removal from their packing, use anti-static containers.
- Do not allow loads to be applied directly to devices while they are in storage.
- If devices have been stored for more than two years under normal storage conditions, it is recommended that you check the leads for ease of soldering prior to use.

Land Pattern Dimensions for Reference Only

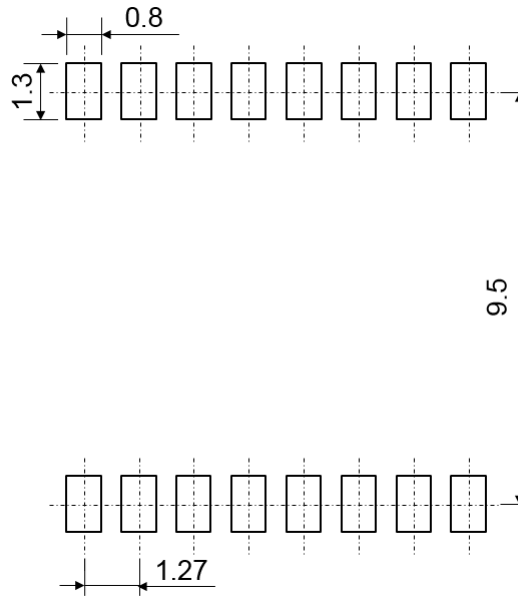

Unit: mm

Marking

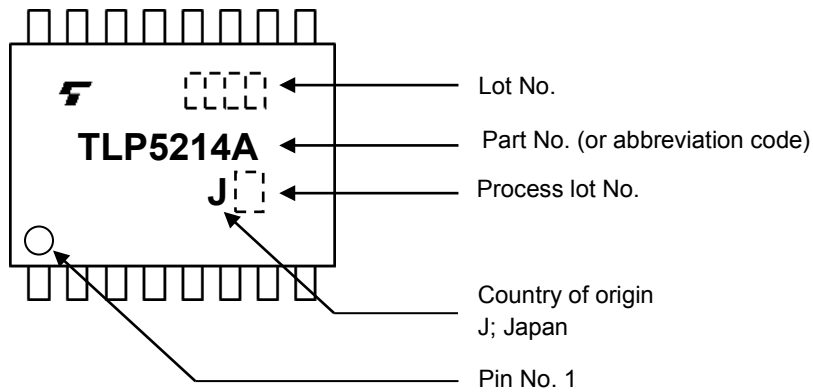

1. Ordering Method

When placing an order, please specify the part number, the tape and the quantity (Multiples of 1500) as shown in the following example.

Example) TLP5214A(TP,E 1500 pcs

Part number: TLP5214A

Tape type: TP (12-mm pitch)

[[G]]/RoHS COMPATIBLE: E (Note 1)

Quantity (must be a multiple of 1500): 1500 pcs

Note 1 :Please contact your Toshiba sales representative for details on environmental information such as the product's RoHS compatibility.

RoHS is the Directive 2011/65/EU of the European Parliament and of the Council of 8 June 2011 on the restriction of the use of certain hazardous substances in electrical and electronic equipment.

RESTRICTIONS ON PRODUCT USE

Toshiba Corporation and its subsidiaries and affiliates are collectively referred to as "TOSHIBA". Hardware, software and systems described in this document are collectively referred to as "Product".

- TOSHIBA reserves the right to make changes to the information in this document and related Product without notice.
- This document and any information herein may not be reproduced without prior written permission from TOSHIBA. Even with TOSHIBA's written permission, reproduction is permissible only if reproduction is without alteration/omission.
- Though TOSHIBA works continually to improve Product's quality and reliability, Product can malfunction or fail. Customers are responsible for complying with safety standards and for providing adequate designs and safeguards for their hardware, software and systems which minimize risk and avoid situations in which a malfunction or failure of Product could cause loss of human life, bodily injury or damage to property, including data loss or corruption. Before customers use the Product, create designs including the Product, or incorporate the Product into their own applications, customers must also refer to and comply with (a) the latest versions of all relevant TOSHIBA information, including without limitation, this document, the specifications, the data sheets and application notes for Product and the precautions and conditions set forth in the "TOSHIBA Semiconductor Reliability Handbook" and (b) the instructions for the application with which the Product will be used with or for. Customers are solely responsible for all aspects of their own product design or applications, including but not limited to (a) determining the appropriateness of the use of this Product in such design or applications; (b) evaluating and determining the applicability of any information contained in this document, or in charts, diagrams, programs, algorithms, sample application circuits, or any other referenced documents; and (c) validating all operating parameters for such designs and applications. **TOSHIBA ASSUMES NO LIABILITY FOR CUSTOMERS' PRODUCT DESIGN OR APPLICATIONS.**
- **PRODUCT IS NEITHER INTENDED NOR WARRANTED FOR USE IN EQUIPMENTS OR SYSTEMS THAT REQUIRE EXTRAORDINARILY HIGH LEVELS OF QUALITY AND/OR RELIABILITY, AND/OR A MALFUNCTION OR FAILURE OF WHICH MAY CAUSE LOSS OF HUMAN LIFE, BODILY INJURY, SERIOUS PROPERTY DAMAGE AND/OR SERIOUS PUBLIC IMPACT ("UNINTENDED USE").** Except for specific applications as expressly stated in this document, Unintended Use includes, without limitation, equipment used in nuclear facilities, equipment used in the aerospace industry, lifesaving and/or life supporting medical equipment, equipment used for automobiles, trains, ships and other transportation, traffic signaling equipment, equipment used to control combustions or explosions, safety devices, elevators and escalators, and devices related to power plant. **IF YOU USE PRODUCT FOR UNINTENDED USE, TOSHIBA ASSUMES NO LIABILITY FOR PRODUCT.** For details, please contact your TOSHIBA sales representative or contact us via our website.
- Do not disassemble, analyze, reverse-engineer, alter, modify, translate or copy Product, whether in whole or in part.
- Product shall not be used for or incorporated into any products or systems whose manufacture, use, or sale is prohibited under any applicable laws or regulations.
- The information contained herein is presented only as guidance for Product use. No responsibility is assumed by TOSHIBA for any infringement of patents or any other intellectual property rights of third parties that may result from the use of Product. No license to any intellectual property right is granted by this document, whether express or implied, by estoppel or otherwise.
- **ABSENT A WRITTEN SIGNED AGREEMENT, EXCEPT AS PROVIDED IN THE RELEVANT TERMS AND CONDITIONS OF SALE FOR PRODUCT, AND TO THE MAXIMUM EXTENT ALLOWABLE BY LAW, TOSHIBA (1) ASSUMES NO LIABILITY WHATSOEVER, INCLUDING WITHOUT LIMITATION, INDIRECT, CONSEQUENTIAL, SPECIAL, OR INCIDENTAL DAMAGES OR LOSS, INCLUDING WITHOUT LIMITATION, LOSS OF PROFITS, LOSS OF OPPORTUNITIES, BUSINESS INTERRUPTION AND LOSS OF DATA, AND (2) DISCLAIMS ANY AND ALL EXPRESS OR IMPLIED WARRANTIES AND CONDITIONS RELATED TO SALE, USE OF PRODUCT, OR INFORMATION, INCLUDING WARRANTIES OR CONDITIONS OF MERCHANTABILITY, FITNESS FOR A PARTICULAR PURPOSE, ACCURACY OF INFORMATION, OR NONINFRINGEMENT.**
- GaAs (Gallium Arsenide) is used in Product. GaAs is harmful to humans if consumed or absorbed, whether in the form of dust or vapor. Handle with care and do not break, cut, crush, grind, dissolve chemically or otherwise expose GaAs in Product.
- Do not use or otherwise make available Product or related software or technology for any military purposes, including without limitation, for the design, development, use, stockpiling or manufacturing of nuclear, chemical, or biological weapons or missile technology products (mass destruction weapons). Product and related software and technology may be controlled under the applicable export laws and regulations including, without limitation, the Japanese Foreign Exchange and Foreign Trade Law and the U.S. Export Administration Regulations. Export and re-export of Product or related software or technology are strictly prohibited except in compliance with all applicable export laws and regulations.
- Please contact your TOSHIBA sales representative for details as to environmental matters such as the RoHS compatibility of Product. Please use Product in compliance with all applicable laws and regulations that regulate the inclusion or use of controlled substances, including without limitation, the EU RoHS Directive. **TOSHIBA ASSUMES NO LIABILITY FOR DAMAGES OR LOSSES OCCURRING AS A RESULT OF NONCOMPLIANCE WITH APPLICABLE LAWS AND REGULATIONS.**