



IS3H7

DESCRIPTION

The IS3H7 series optocoupler consists of an infrared emitting diode optically coupled to an NPN silicon photo transistor.

This device belongs to Isocom Compact Range of Optocouplers.

FEATURES

- Half Pitch 1.27mm
- High AC Isolation voltage 3750V_{RMS}
- CTR Selections Available
- Wide Operating Temperature Range -55°C to 110°C
- Pb Free and RoHS Compliant
- UL Approval E91231, Model THP

APPLICATIONS

- Switching Mode Power Supply
- Industrial System Controllers
- Measuring Instruments
- Signal Transmission between Systems of Different Potentials and Impedances

ORDER INFORMATION

- Available in Tape and Reel with 1000pcs per reel

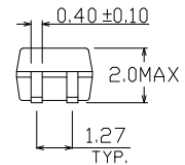
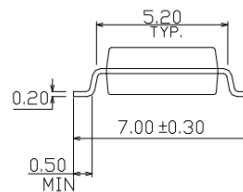
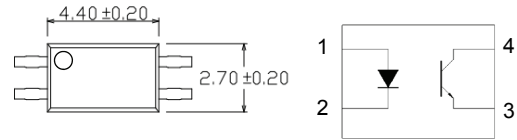

All dimensions in mm.

ABSOLUTE MAXIMUM RATINGS (T_A = 25°C)

Input Diode

Forward Current	50mA
Reverse Voltage	6V
Power dissipation	70mW

Output Transistor

Collector to Emitter Voltage BV _{CEO}	80V
Emitter to Collector Voltage BV _{ECO}	7V
Collector Current	50mA
Power Dissipation	150mW

Total Package

Isolation Voltage	3750V _{RMS}
Total Power Dissipation	200mW
Operating Temperature	-55 to 110 °C
Storage Temperature	-55 to 125 °C
Lead Soldering Temperature (10s)	260°C

ISOCOM COMPONENTS 2004 LTD

Unit 25B, Park View Road West, Park View Industrial Estate
Hartlepool, Cleveland, TS25 1UD, United Kingdom
Tel: +44 (0)1429 863 609 Fax : +44 (0)1429 863 581
e-mail: sales@isocom.co.uk
<http://www.isocom.com>

ISOCOM COMPONENTS ASIA LTD

Hong Kong Office,
Block A, 8/F, Wah Hing Industrial mansion,
36 Tai Yau Street, San Po Kong, Kowloon, Hong Kong.
Tel: +852 2995 9217 Fax : +852 8161 6292
e-mail: sales@isocom.com.hk



IS3H7

ELECTRICAL CHARACTERISTICS ($T_A = 25^\circ\text{C}$ unless otherwise specified)

INPUT

Parameter	Symbol	Test Condition	Min	Typ.	Max	Unit
Forward Voltage	V_F	$I_F = 20\text{mA}$		1.2	1.4	V
Reverse Current	I_R	$V_R = 4\text{V}$			10	μA
Input Capacitance	C_{IN}	$V_F = 0\text{V}, f = 1\text{KHz}$		30	250	pF

OUTPUT

Parameter	Symbol	Test Condition	Min	Typ.	Max	Unit
Collector-Emitter breakdown Voltage	BV_{CEO}	$I_C = 0.1\text{mA}, I_F = 0\text{mA}$	80			V
Emitter-Collector breakdown Voltage	BV_{ECO}	$I_E = 0.1\text{mA}, I_F = 0\text{mA}$	7			V
Collector-Emitter Dark Current	I_{CEO}	$V_{CE} = 20\text{V}, I_F = 0\text{mA}$			100	nA



IS3H7

ELECTRICAL CHARACTERISTICS ($T_A = 25^\circ\text{C}$ unless otherwise specified)

COUPLED

Parameter	Symbol	Test Condition	Min	Typ.	Max	Unit	
Current transfer ratio	CTR	$I_F = 5\text{mA}$, $V_{CE} = 5\text{V}$				%	
		IS3H&	50		600		
		IS3H&A	80		160		
		IS3H&B	130		260		
		IS3H&C	200		400		
		IS3H&D	300		600		
		IS3H&E	100		200		
		IS3H&F	150		300		
		$I_F = 10\text{mA}$, $V_{CE} = 5\text{V}$					
		IS3H&H	40		80		
		IS3H&I	63		125		
		IS3H&J	100		200		
		IS3H&K	160		320		
		IS3H&GR	100		300		
IS3H&GB	100		600				
Collector-Emitter Saturation Voltage	$V_{CE(sat)}$	$I_F = 10\text{mA}$, $I_C = 1\text{mA}$		0.1	0.2	V	
Input to Output Isolation Voltage	V_{ISO}	See note 1	3750			V_{RMS}	
Input to Output Isolation Resistance	R_{ISO}	$V_{IO} = 500\text{V}$ See note 1	5×10^{10}			Ω	
Floating Capacitance	C_f	$V_F = 0\text{V}$, $f = 1\text{MHz}$		0.3		pF	
Output Rise Time	t_r	$V_{CE} = 2\text{V}$, $I_C = 2\text{mA}$, $R_L = 100\Omega$		6	18	μs	
Output Fall Time	t_f	$V_{CE} = 2\text{V}$, $I_C = 2\text{mA}$, $R_L = 100\Omega$		6	18	μs	

Note 1 : Measured with input leads shorted together and output leads shorted together, R.H 40% to 60%



IS3H7

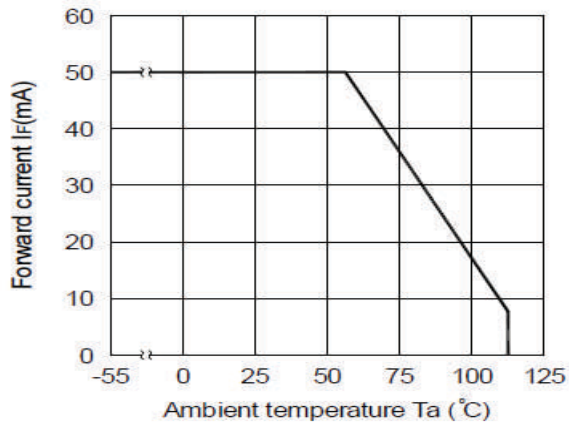

Fig 1 Forward Current vs Ambient Temperature

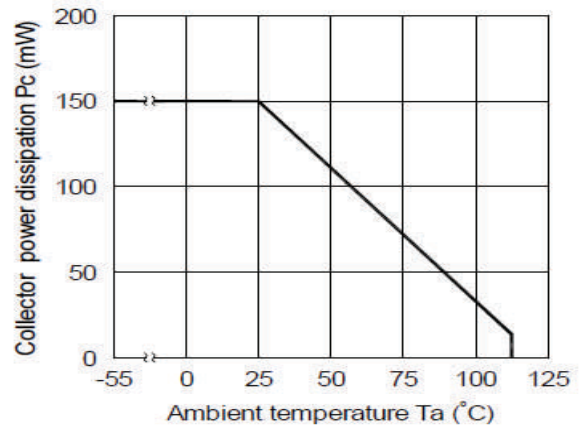

Fig 2 Collector Power Dissipation vs T_A

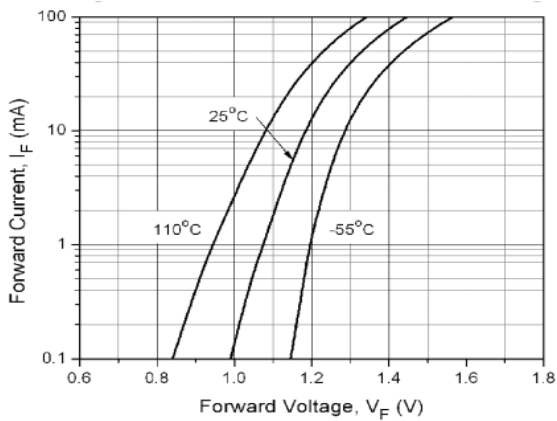

Fig 3 Forward Current vs Forward Voltage

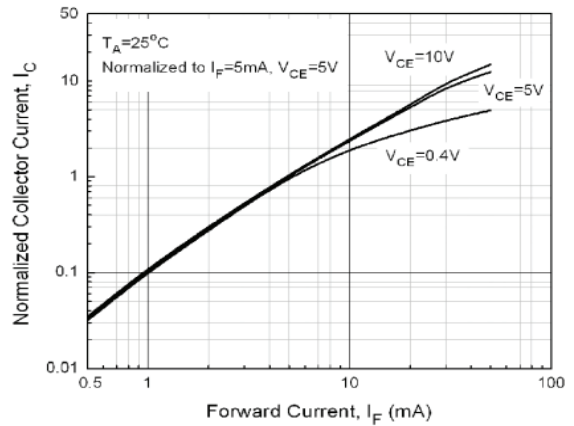

Fig 4 Normalized Collector Current vs Forward Current

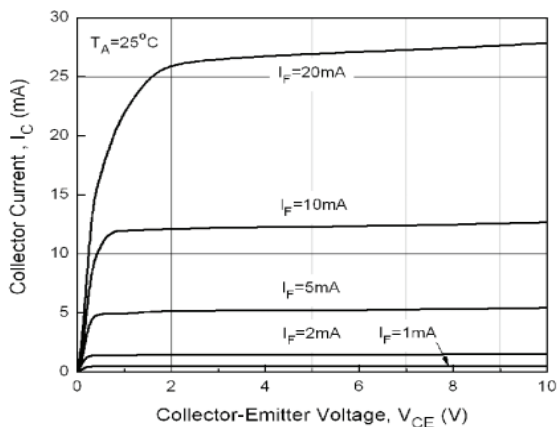

Fig 5 Collector Current vs Collector-Emitter Voltage (1)

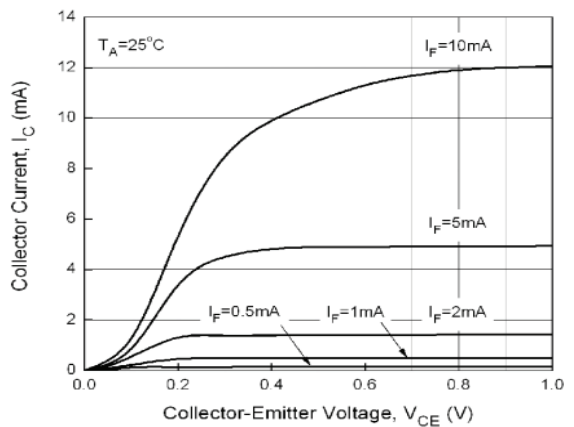

Fig 6 Collector Current vs Collector-Emitter Voltage (2)



IS3H7

ORDER INFORMATION

IS3H&			
After PN	PN	Description	Packing quantity
None	IS3H&	Surface Mount Tape & Reel	1000 pcs per reel
Any CTR Grade	IS3H&A, IS3H&B, IS3H&C, IS3H&D, IS3H&E, IS3H&F, IS3H&H, IS3H&I, IS3H&J, IS3H&K, IS3H&GR, IS3H&GB	Surface Mount Tape & Reel	1000 pcs per reel

DEVICE MARKING

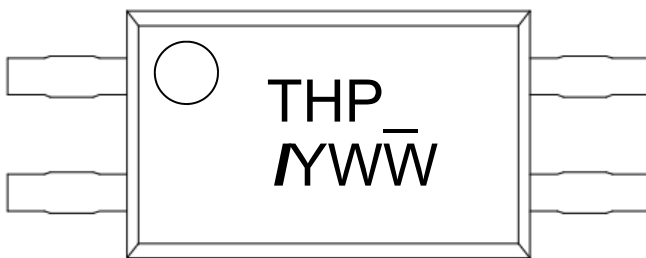

THP_ denotes Device Part Number where “_” denoted CTR Grade
I denotes Isocom
Y denotes 1 digit Year code
WW denotes 2 digit Week code



IS3H7

PACKAGE DIMENSIONS (mm)

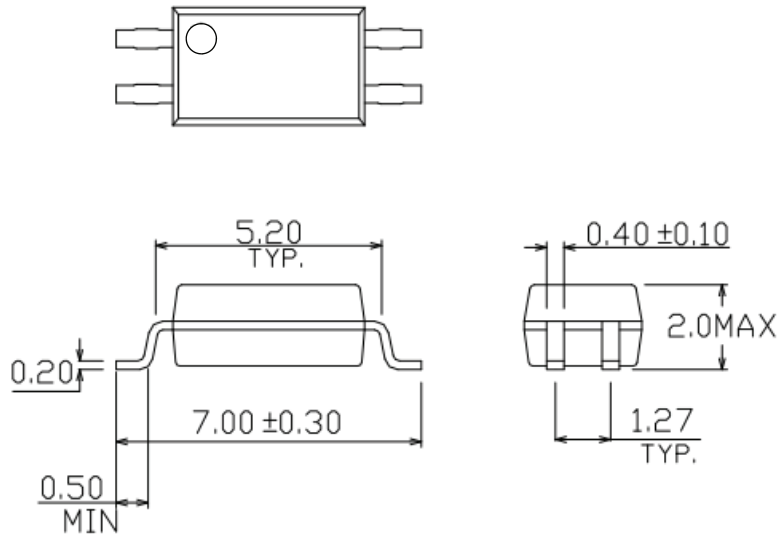

RECOMMENDED SOLDER PAD LAYOUT (mm)

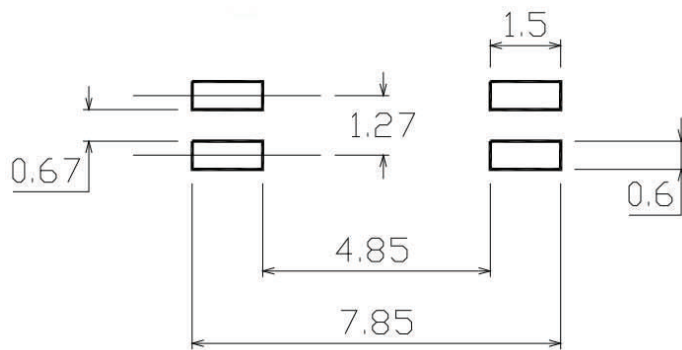



IS3H7

IR REFLOW SOLDERING TEMPERATURE PROFILE

(One Time Reflow Soldering is Recommended)

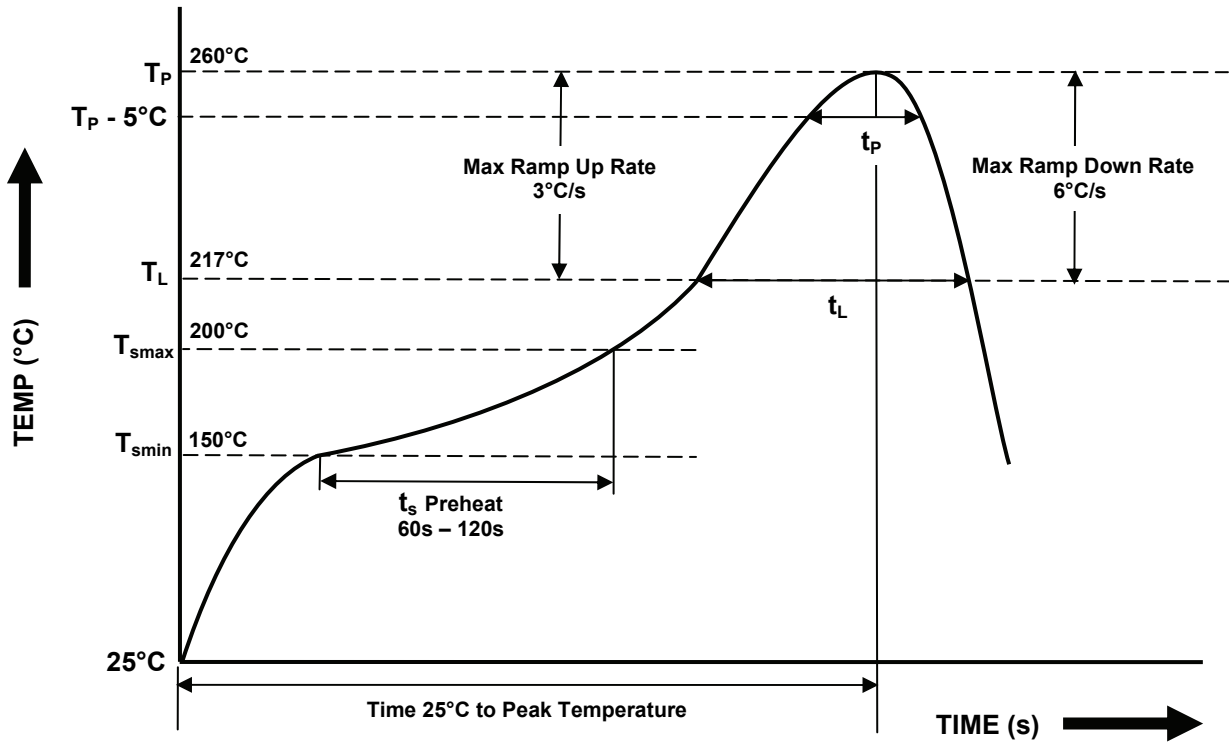

Profile Details	Conditions
Preheat - Min Temperature (T _{SMIN}) - Max Temperature (T _{SMAX}) - Time T _{SMIN} to T _{SMAX} (t _s)	150°C 200°C 60s – 120s
Soldering Zone - Peak Temperature (T _P) - Liquidous Temperature (T _L) - Time within 5°C of Actual Peak Temperature (T _P – 5°C) - Time maintained above T _L (t _L) - Ramp Up Rate (T _L to T _P) - Ramp Down Rate (T _P to T _L)	260°C 217°C 30s 60s – 100s 3°C/s max 6°C/s max
Average Ramp Up Rate (T _{smax} to T _P)	3°C/s max
Time 25°C to Peak Temperature	8 minutes max



IS3H7

Tape and Reel Packaging

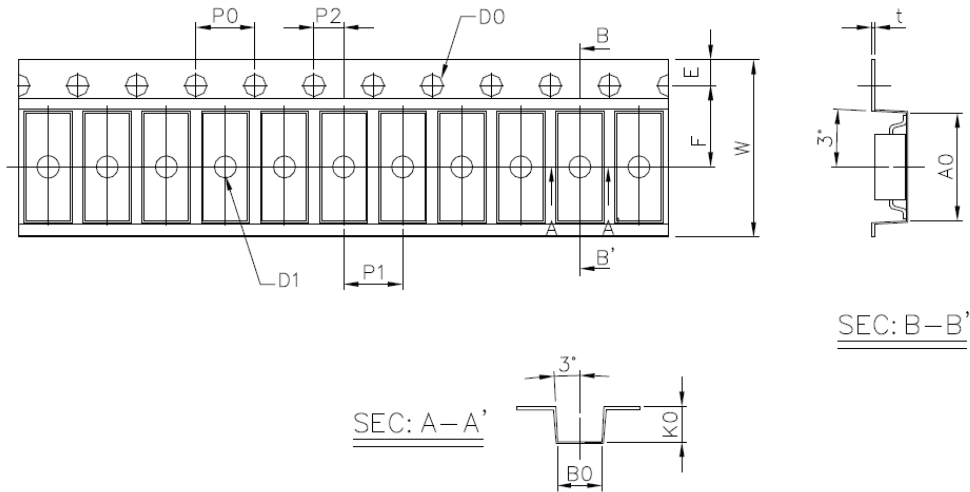

Dimension No.	A	B	Do	D1	E	F
Dimension (mm)	3.0 ± 0.1	7.3 ± 0.1	1.5 + 0.1/-0	1.5 ± 0.1	1.75 ± 0.1	5.5 ± 0.1
Dimension No.	Po	P1	P2	t	W	K
Dimension (mm)	4.0 ± 0.15	4.0 ± 0.1	2.0 ± 0.1	0.25 ± 0.03	12.0 ± 0.2	2.4 ± 0.1

