

TOSHIBA Photocoupler GaAlAs Ired & Photo-IC

# TLP251F

- Inverter for Air Conditioner
- Induction Heating
- Transistor Inverter
- Power MOSFET Gate Drive
- IGBT Gate Drive

The TOSHIBA TLP251F consists of a GaAlAs light emitting diode and an integrated photodetector.  
 This unit is 8-lead DIP package.  
 TLP251F is suitable for gate driving circuit of IGBT or power MOS FET.  
 Especially TLP251 is capable of "direct" gate drive of lower power IGBTs. (~15A)

- Input threshold current:  $I_F = 5\text{mA}$  (max.)
- Supply current: 11mA (max.)
- Supply voltage: 10~35V
- Output peak current:  $\pm 0.4\text{A}$  (max.)
- Switching time:  $t_{pHL}, t_{pLH} = 1\mu\text{s}$  (max.)
- Isolation voltage:  $2500V_{\text{rms}}$ (min.)
- UL recognized: UL1577, file no. E67349
- Option (D4) type  
 VDE approved: DIN EN 60747-5-2, certificate no. 40011913  
 Maximum operating insulation voltage: 1140V<sub>PK</sub>  
 Highest permissible over voltage: 6000V<sub>PK</sub>

**(Note 1) When a EN 60747-5-2 approved type is needed, please designate the " Option (D4) "**

- Structural parameter  
 Creepage distance: 8.0mm (min.)  
 Clearance: 8.0mm (min.)

Unit in mm

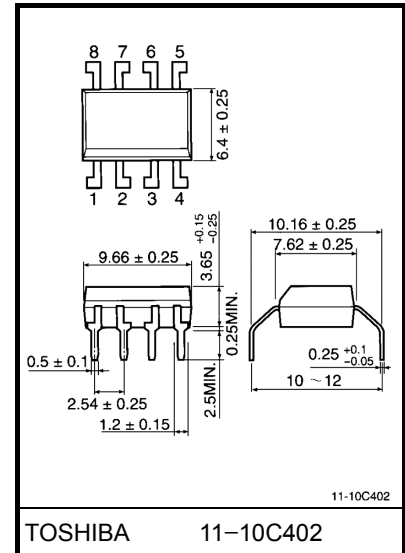

Weight: 0.54g

**Truth Table**

		Tr1	Tr2
		On	Off
Input LED	On	On	Off
	Off	Off	On

**Pin Configuration (top view)**

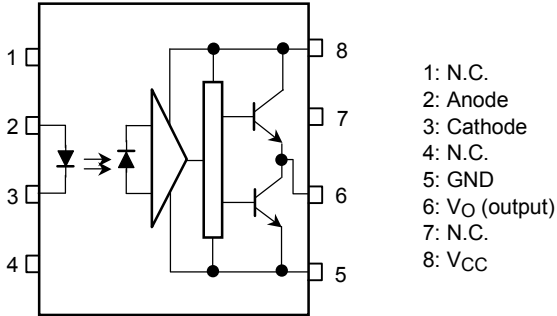

**Schematic**

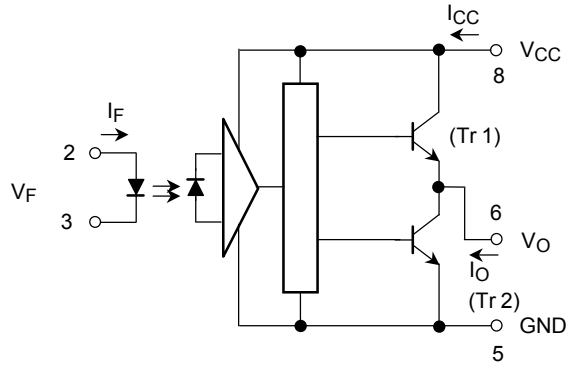

(Note 2 ) A 0.1 $\mu$ F bypass capacitor must be connected between pin 8 and 5.

**RESTRICTIONS ON PRODUCT USE**

20070701-EN

- The information contained herein is subject to change without notice.
- TOSHIBA is continually working to improve the quality and reliability of its products. Nevertheless, semiconductor devices in general can malfunction or fail due to their inherent electrical sensitivity and vulnerability to physical stress. It is the responsibility of the buyer, when utilizing TOSHIBA products, to comply with the standards of safety in making a safe design for the entire system, and to avoid situations in which a malfunction or failure of such TOSHIBA products could cause loss of human life, bodily injury or damage to property.  
In developing your designs, please ensure that TOSHIBA products are used within specified operating ranges as set forth in the most recent TOSHIBA products specifications. Also, please keep in mind the precautions and conditions set forth in the "Handling Guide for Semiconductor Devices," or "TOSHIBA Semiconductor Reliability Handbook" etc.
- The TOSHIBA products listed in this document are intended for usage in general electronics applications (computer, personal equipment, office equipment, measuring equipment, industrial robotics, domestic appliances, etc.). These TOSHIBA products are neither intended nor warranted for usage in equipment that requires extraordinarily high quality and/or reliability or a malfunction or failure of which may cause loss of human life or bodily injury ("Unintended Usage"). Unintended Usage include atomic energy control instruments, airplane or spaceship instruments, transportation instruments, traffic signal instruments, combustion control instruments, medical instruments, all types of safety devices, etc.. Unintended Usage of TOSHIBA products listed in this document shall be made at the customer's own risk.
- The products described in this document shall not be used or embedded to any downstream products of which manufacture, use and/or sale are prohibited under any applicable laws and regulations.
- The information contained herein is presented only as a guide for the applications of our products. No responsibility is assumed by TOSHIBA for any infringements of patents or other rights of the third parties which may result from its use. No license is granted by implication or otherwise under any patents or other rights of TOSHIBA or the third parties.
- GaAs(Gallium Arsenide) is used in this product. The dust or vapor is harmful to the human body. Do not break, cut, crush or dissolve chemically.
- Please contact your sales representative for product-by-product details in this document regarding RoHS compatibility. Please use these products in this document in compliance with all applicable laws and regulations that regulate the inclusion or use of controlled substances. Toshiba assumes no liability for damage or losses occurring as a result of noncompliance with applicable laws and regulations.