

TLP2200

- Isolated Buss Driver
- High Speed Line Receiver
- Microprocessor System Interfaces
- MOS FET Gate Driver
- Direct Replacement For HCPL-2200

The TOSHIBA TLP2200 consists of a GaAlAs light emitting diode and integrated high gain, high speed photodetector. This unit is 8-lead DIP package. The detector has a three state output stage that eliminates the need for pull-up resistor, and built-in schmitt trigger. The detector IC has an internal shield that provides a guaranteed common mode transient immunity of 1000V / μ s.

- Input current: $I_F = 1.6\text{mA}$
- Power supply voltage: $V_{CC} = 4.5\sim 20\text{V}$
- Switching speed: 2.5MBd guaranteed
- Common mode transient immunity: $\pm 1000\text{V} / \mu\text{s}$ (min.)
- Guaranteed performance over temp: $0\sim 85^\circ\text{C}$
- Isolation voltage: 2500Vrms(min.)
- UL recognized: UL1577, file No. E67349

Truth Table (positive logic)

Input	Enable	Output
H	H	Z
L	H	Z
H	L	H
L	L	L

Unit in mm

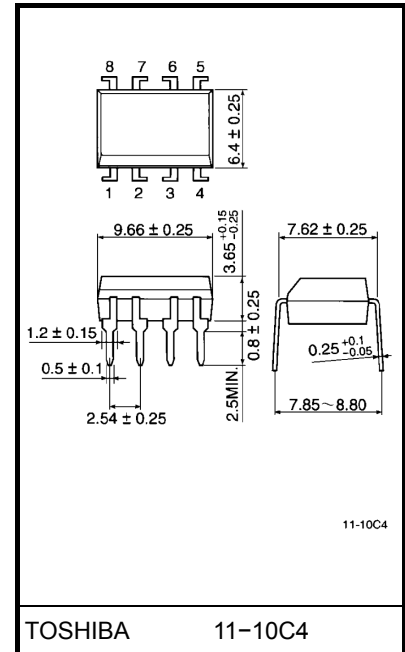

Weight: 0.54 g

Pin Configuration (top view)

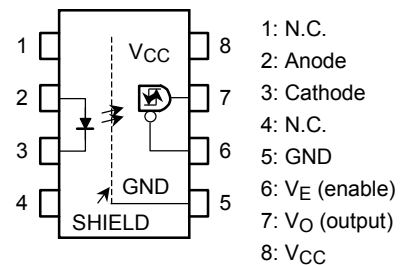

Schematic

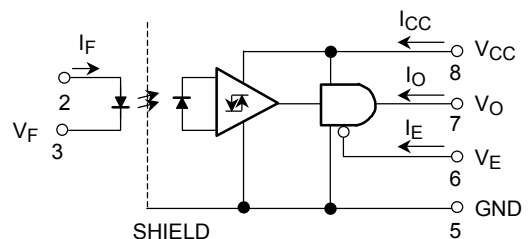

Recommended Operating Conditions

Characteristic	Symbol	Min.	Typ.	Max.	Unit
Input current, on	$I_{F(ON)}$	1.6	—	5	mA
Input current, off	$I_{F(OFF)}$	0	—	0.1	mA
Supply voltage	V_{CC}	4.5	—	20	V
Enable voltage high	V_{EH}	2.0	—	20	V
Enable voltage low	V_{EL}	0	—	0.8	V
Fan out (TTL load)	N	—	—	4	—
Operating temperature	T_{opr}	0	—	85	°C

Note: Recommended operating conditions are given as a design guideline to obtain expected performance of the device. Additionally, each item is an independent guideline respectively. In developing designs using this product, please confirm specified characteristics shown in this document.

Absolute Maximum Ratings (no derating required up to 70°C)

Characteristic		Symbol	Rating	Unit
□ □ □	Forward current	I_F	10	mA
	Peak transient forward current (Note 1)	I_{FPT}	1	A
	Reverse voltage	V_R	5	V
□ □ □ □ □ □	Output current	I_O	25	mA
	Supply voltage	V_{CC}	-0.5~20	V
	Output voltage	V_O	-0.5~20	V
	Three state enable voltage	V_E	-0.5~20	V
	Total package power dissipation (Note 2)	P_T	210	mW
	Operating temperature range	T_{opr}	-40~85	°C
Storage temperature range		T_{stg}	-55~125	°C
Lead solder temperature (10s) (**)		T_{sol}	260	°C
Isolation voltage (AC 1min., R.H. ≤ 60%, $T_a = 25^\circ\text{C}$) (Note 3)		BV_S	2500	Vrms

Note: Using continuously under heavy loads (e.g. the application of high temperature/current/voltage and the significant change in temperature, etc.) may cause this product to decrease in the reliability significantly even if the operating conditions (i.e. operating temperature/current/voltage, etc.) are within the absolute maximum ratings.

Please design the appropriate reliability upon reviewing the Toshiba Semiconductor Reliability Handbook ("Handling Precautions"/"Derating Concept and Methods") and individual reliability data (i.e. reliability test report and estimated failure rate, etc).

(Note 1) Pulse width 1μs 300pps.

(Note 2) Derate 4.5mW / °C above 70°C ambient temperature.

(Note 3) Device considered a two terminal device: Pins 1, 2, 3 and 4 shorted together, and pins 5,6,7 and 8 shorted together

(**) 1.6mm below seating plane.

Electrical Characteristics (unless otherwise specified, $T_a = 0\sim 85^\circ\text{C}$, $V_{CC} = 4.5\sim 20\text{V}$, $I_{F(\text{ON})} = 1.6\sim 5\text{mA}$, $I_{F(\text{OFF})} = 0\sim 0.1\text{mA}$, $V_{EL} = 0\sim 0.8\text{V}$, $V_{EH} = 2.0\sim 20\text{V}$)

Characteristic	Symbol	Test Condition		Min.	Typ.*	Max.	Unit
Output leakage current ($V_O > V_{CC}$)	I_{OHH}	$I_F = 5\text{mA}$, $V_{CC} = 4.5\text{V}$	$V_O = 5.5\text{V}$	—	—	100	μA
			$V_O = 20\text{V}$	—	2	500	
Logic low output voltage	V_{OL}	$I_{OL} = 6.4\text{mA}$ (4 TTL load)		—	0.32	0.5	V
Logic high output voltage	V_{OH}	$I_{OH} = -2.6\text{mA}$		2.4	3.4	—	V
Logic low enable current	I_{EL}	$V_E = 0.4\text{V}$		—	-0.13	-0.32	mA
Logic high enable current	I_{EH}	$V_E = 2.7\text{V}$		—	—	20	μA
		$V_E = 5.5\text{V}$		—	—	100	
		$V_E = 20\text{V}$		—	0.01	250	
Logic low enable voltage	V_{EL}	—		—	—	0.8	V
Logic high enable voltage	V_{EH}	—		2.0	—	—	V
Logic low supply current	I_{CCL}	$I_F = 0\text{mA}$ $V_E = \text{don't care}$	$V_{CC} = 5.5\text{V}$	—	5	6.0	mA
			$V_{CC} = 20\text{V}$	—	5.6	7.5	
Logic high supply current	I_{CCH}	$I_F = 5\text{mA}$ $V_E = \text{don't care}$	$V_{CC} = 5.5\text{V}$	—	2.5	4.5	mA
			$V_{CC} = 20\text{V}$	—	2.8	6.0	
High impedance state output current	I_{OZL}	$I_F = 5\text{mA}$ $V_E = 2\text{V}$	$V_O = 0.4\text{V}$	—	1	-20	μA
			$V_O = 2.4\text{V}$	—	—	20	
	I_{OZH}	$I_F = 0\text{mA}$ $V_E = 2\text{V}$	$V_O = 5.5\text{V}$	—	—	100	
			$V_O = 20\text{V}$	—	0.01	500	
Logic low short circuit output current (Note 4)	I_{OSL}	$I_F = 0\text{mA}$	$V_O = V_{CC} = 5.5\text{V}$	25	55	—	mA
			$V_O = V_{CC} = 20\text{V}$	40	80	—	
Logic high short circuit output current (Note 4)	I_{OSH}	$I_F = 5\text{mA}$ $V_O = \text{GND}$	$V_{CC} = 5.5\text{V}$	-10	-25	—	mA
			$V_{CC} = 20\text{V}$	-25	-60	—	
Input current hysteresis	I_{HYS}	$V_{CC} = 5\text{V}$		—	0.05	—	mA
Input forward voltage	V_F	$I_F = 5\text{mA}$, $T_a = 25^\circ\text{C}$		—	1.55	1.7	V
Temperature coefficient of forward voltage	$\Delta V_F / \Delta T_a$	$I_F = 5\text{mA}$		—	-2.0	—	mV / $^\circ\text{C}$
Input reverse breakdown voltage	BV_R	$I_R = 10\mu\text{A}$, $T_a = 25^\circ\text{C}$		5	—	—	V
Input capacitance	C_{IN}	$V_F = 0\text{V}$, $f = 1\text{MHz}$, $T_a = 25^\circ\text{C}$		—	45	—	pF
Resistance (input-output)	R_{I-O}	$V_{I-O} = 500\text{V}$ R.H. $\leq 60\%$ (Note 3)		5×10^{10}	10^{14}	—	Ω
Capacitance (input-output)	C_{I-O}	$V_{I-O} = 0\text{V}$, $f = 1\text{MHz}$ (Note 3)		—	0.6	—	pF

(**) All typ. values are at $T_a = 25^\circ\text{C}$, $V_{CC} = 5\text{V}$, $I_{F(\text{ON})} = 3\text{mA}$ unless otherwise specified.

Switching Characteristics

(unless otherwise specified, $T_a = 0\sim 85^\circ\text{C}$, $V_{CC} = 4.5\sim 20\text{V}$, $I_{F(ON)} = 1.6\sim 5\text{mA}$, $I_{F(OFF)} = 0\sim 0.1\text{mA}$)

Characteristic	Symbol	Test Circuit	Test Condition	Min.	Typ.	Max.	Unit
Propagation delay time to logic high output level (Note 5)	t_{pLH}	1	Without peaking capacitor C_1	—	235	—	ns
			With peaking capacitor C_1	—	—	400	
Propagation delay time to logic low output level (Note 5)	t_{pHL}		Without peaking capacitor C_1	—	250	—	ns
			With peaking capacitor C_1	—	—	400	
Output rise time (10–90%)	t_r			—	35	—	ns
Output fall time (90–10%)	t_f			—	20	—	ns
Output enable time to logic high	t_{pZH}	2	—	—	—	ns	
Output enable time to logic low	t_{pZL}		—	—	—	ns	
Output disable time from logic high	t_{pHZ}		—	—	—	ns	
Output disable time from logic low	t_{pLZ}		—	—	—	ns	
Common mode transient immunity at logic high output (Note 6)	CM_H	3	$I_F = 1.6\text{mA}$, $V_{CM} = 50\text{V}$, $T_a = 25^\circ\text{C}$	-1000	—	—	$\text{V} / \mu\text{s}$
Common mode transient immunity at logic low output (Note 6)	CM_L		$I_F = 0\text{mA}$, $V_{CM} = 50\text{V}$, $T_a = 25^\circ\text{C}$	1000	—	—	$\text{V} / \mu\text{s}$

(*) All typ. values are at $T_a = 25^\circ\text{C}$, $V_{CC} = 5\text{V}$, $I_{F(ON)} = 3\text{mA}$ unless otherwise specified.

(Note 4) Duration of output short circuit time should not exceed 10ms.

(Note 5) The t_{pLH} propagation delay is measured from the 50% point on the leading edge of the input pulse to the 1.3V point on the leading edge of the output pulse.The t_{pHL} propagation delay is measured from the 50% point on the trailing edge of the input pulse to the 1.3V point on the trailing edge of the output pulse.(Note 6) CM_L is the maximum rate of rise of the common mode voltage that can be sustained with the output voltage in the logic low state ($V_O \leq 0.8\text{V}$). CM_H is the maximum rate of fall of the common mode voltage that can be sustained with the output voltage in the logic high state ($V_O \leq 2.0\text{V}$).

Test Circuit 1 t_{pHL} , t_{pLH} , t_r and t_f

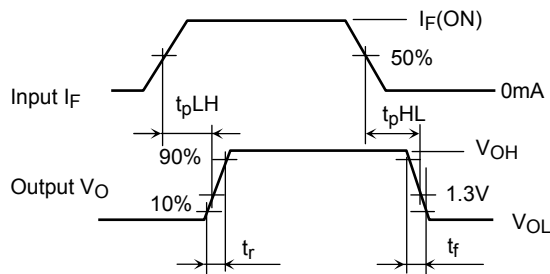

R_1	2.15k Ω	1.1k Ω	681 Ω
$I_F(\text{ON})$	1.6mA	3mA	5mA

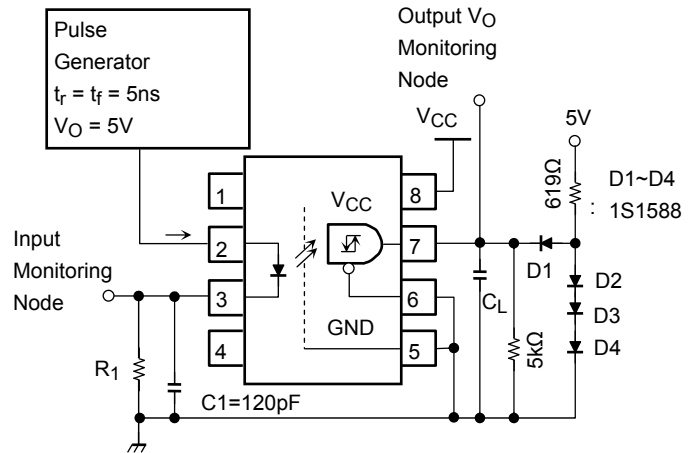

C_1 is peaking capacitor. The probe and jig capacitances are include in C_1 .
 C_L is approximately 15pF which includes probe and stray wiring capacitance.

Test Circuit 2 t_{pHZ} , t_{pZH} , t_{pLZ} and t_{pZL}

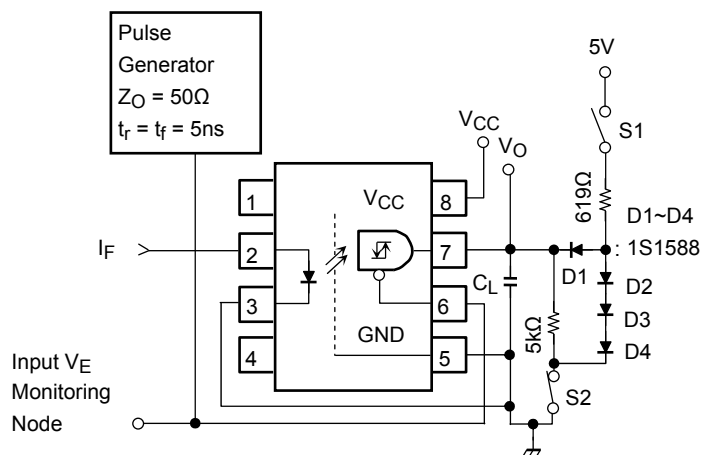
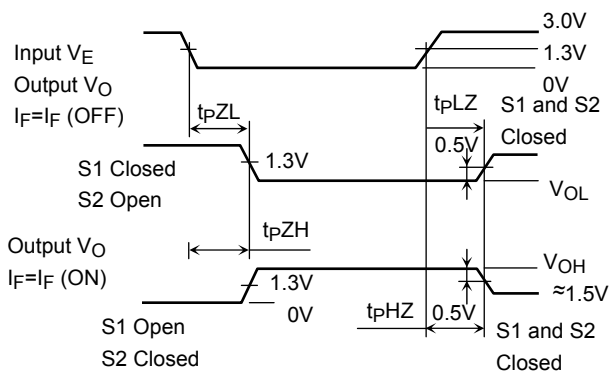

C_L is approximately 15pF which includes probe and stray wiring capacitance.

Test Circuit 3 Common Mode Transient Immunity

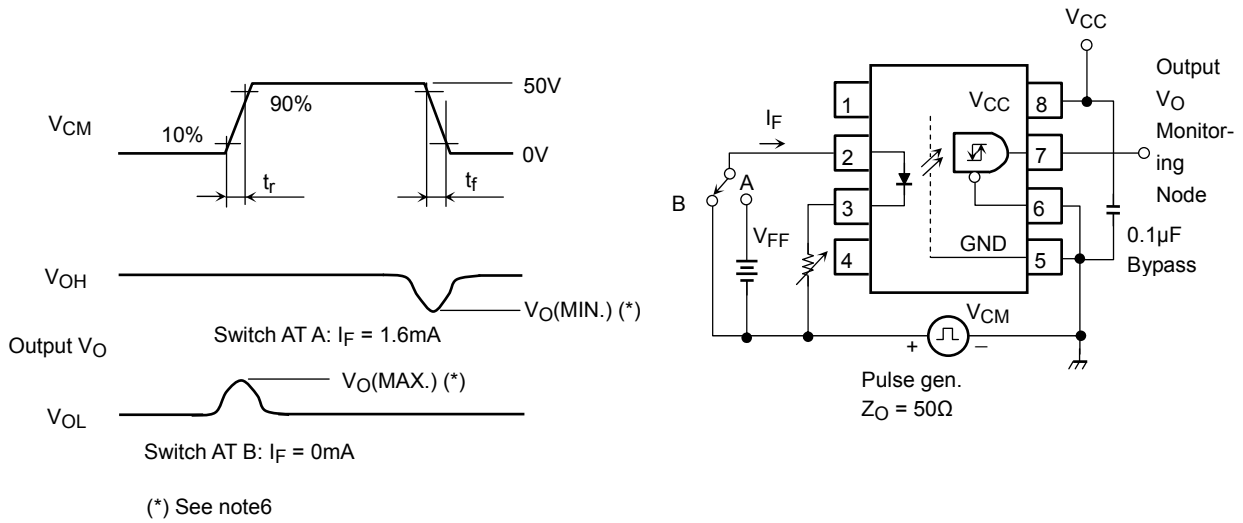

RESTRICTIONS ON PRODUCT USE

20070701-EN

- The information contained herein is subject to change without notice.
- TOSHIBA is continually working to improve the quality and reliability of its products. Nevertheless, semiconductor devices in general can malfunction or fail due to their inherent electrical sensitivity and vulnerability to physical stress. It is the responsibility of the buyer, when utilizing TOSHIBA products, to comply with the standards of safety in making a safe design for the entire system, and to avoid situations in which a malfunction or failure of such TOSHIBA products could cause loss of human life, bodily injury or damage to property.
In developing your designs, please ensure that TOSHIBA products are used within specified operating ranges as set forth in the most recent TOSHIBA products specifications. Also, please keep in mind the precautions and conditions set forth in the "Handling Guide for Semiconductor Devices," or "TOSHIBA Semiconductor Reliability Handbook" etc.
- The TOSHIBA products listed in this document are intended for usage in general electronics applications (computer, personal equipment, office equipment, measuring equipment, industrial robotics, domestic appliances, etc.). These TOSHIBA products are neither intended nor warranted for usage in equipment that requires extraordinarily high quality and/or reliability or a malfunction or failure of which may cause loss of human life or bodily injury ("Unintended Usage"). Unintended Usage include atomic energy control instruments, airplane or spaceship instruments, transportation instruments, traffic signal instruments, combustion control instruments, medical instruments, all types of safety devices, etc.. Unintended Usage of TOSHIBA products listed in this document shall be made at the customer's own risk.
- The products described in this document shall not be used or embedded to any downstream products of which manufacture, use and/or sale are prohibited under any applicable laws and regulations.
- The information contained herein is presented only as a guide for the applications of our products. No responsibility is assumed by TOSHIBA for any infringements of patents or other rights of the third parties which may result from its use. No license is granted by implication or otherwise under any patents or other rights of TOSHIBA or the third parties.
- GaAs(Gallium Arsenide) is used in this product. The dust or vapor is harmful to the human body. Do not break, cut, crush or dissolve chemically.
- Please contact your sales representative for product-by-product details in this document regarding RoHS compatibility. Please use these products in this document in compliance with all applicable laws and regulations that regulate the inclusion or use of controlled substances. Toshiba assumes no liability for damage or losses occurring as a result of noncompliance with applicable laws and regulations.