

# TLE 6711 G/GL

Multifunctional Voltage Regulator and Watchdog

Automotive Power



Never stop thinking



**Features**

- Step up converter (Boost Voltage)
- Boost Over- and Under-Voltage-Lockout
- Step down converter (Logic Voltage)
- 2% output voltage tolerance
- Logic Over- and Under-Voltage-Lockout
- Overtemperature Shutdown
- Power ON/OFF reset generator
- Digital window watchdog
- System Enable Output
- Ambient operation temperature range  
-40 °C to 125 °C
- Wide Supply voltage operation range
- Very low current consumption
- Very small PG-DSO-14-1 SMD package
- Green Product (RoHS Compliant)
- AEC Qualified

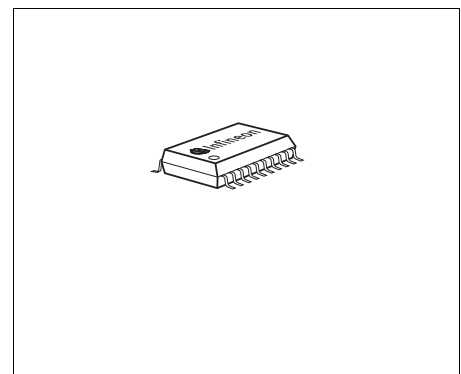
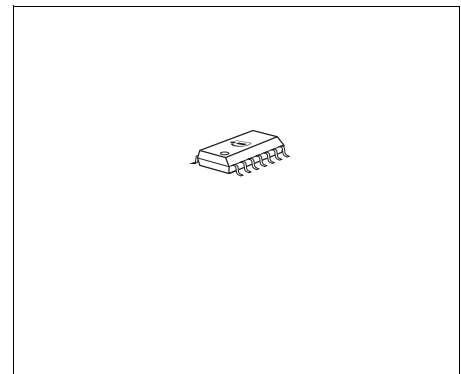

**Description**

The **TLE 6711 G/GL** is a multifunctional power supply circuit especially designed for automotive applications.

It delivers a programmable step up voltage (Boost) and a precise 5 V fully short circuit protected output voltage (Buck).

The **TLE 6711 G/GL** contains a power on reset feature to start up the system, an integrated digital window watchdog to monitor the connected microcontroller and a system enable output to indicate the microcontroller window watchdog faults.

The device is based on Infineon’s power technology SPT® which allows bipolar and CMOS control circuitry to be integrated with DMOS power devices on the same monolithic circuitry.

The very small **PG-DSO-14-1** SMD packages meet the application requirements.

Furthermore, the build-in features like under- and overvoltage lockout for boost- and buck-voltage and the overtemperature shutdown feature increase the reliability of the **TLE 6711 G/GL** supply system.

Type	Package
TLE 6711 G	PG-DSO-14-1
TLE 6711 GL	PG-DSO-20-36

# 1 Block Diagram

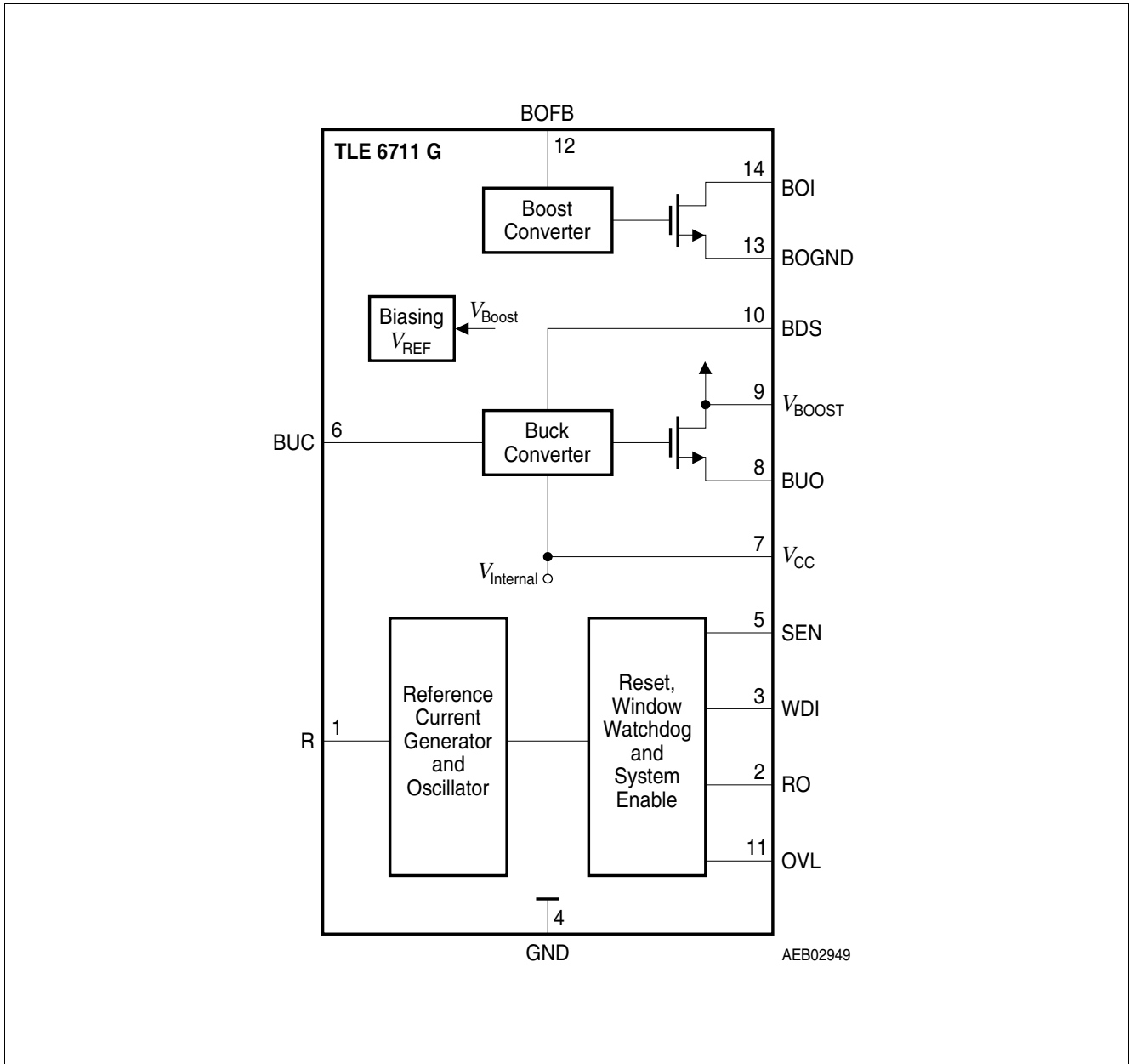

Figure 1 Block Diagram (pinning valid for PG-DSO-14-1)

## 2 Pin Configuration

### 2.1 Pin Assignment

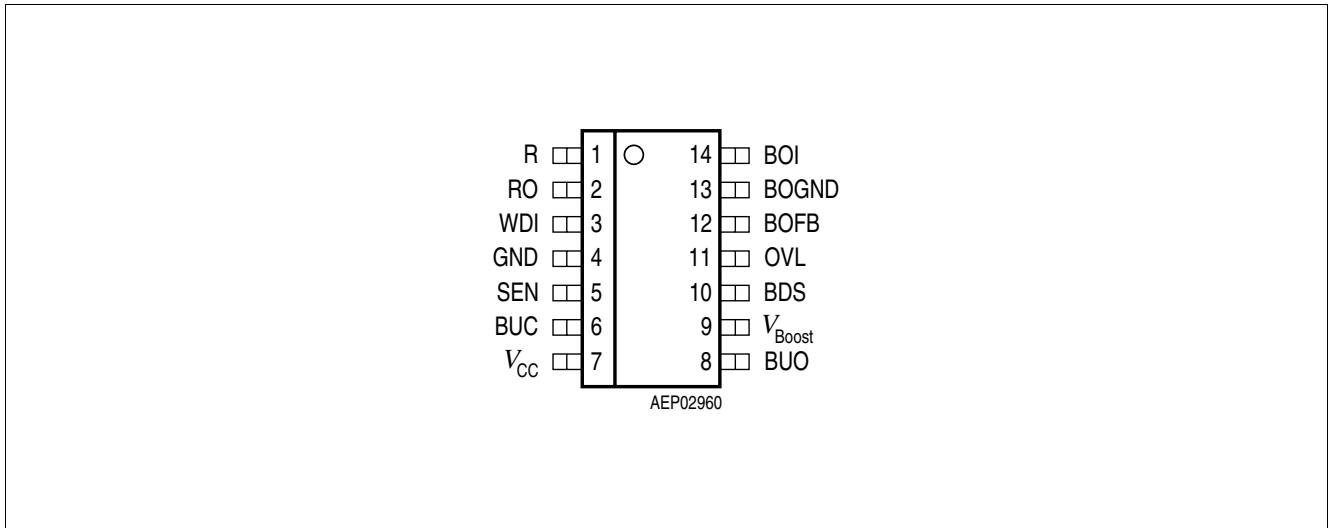

Figure 2 Pin Configuration PG-DSO-14-1 (top view)

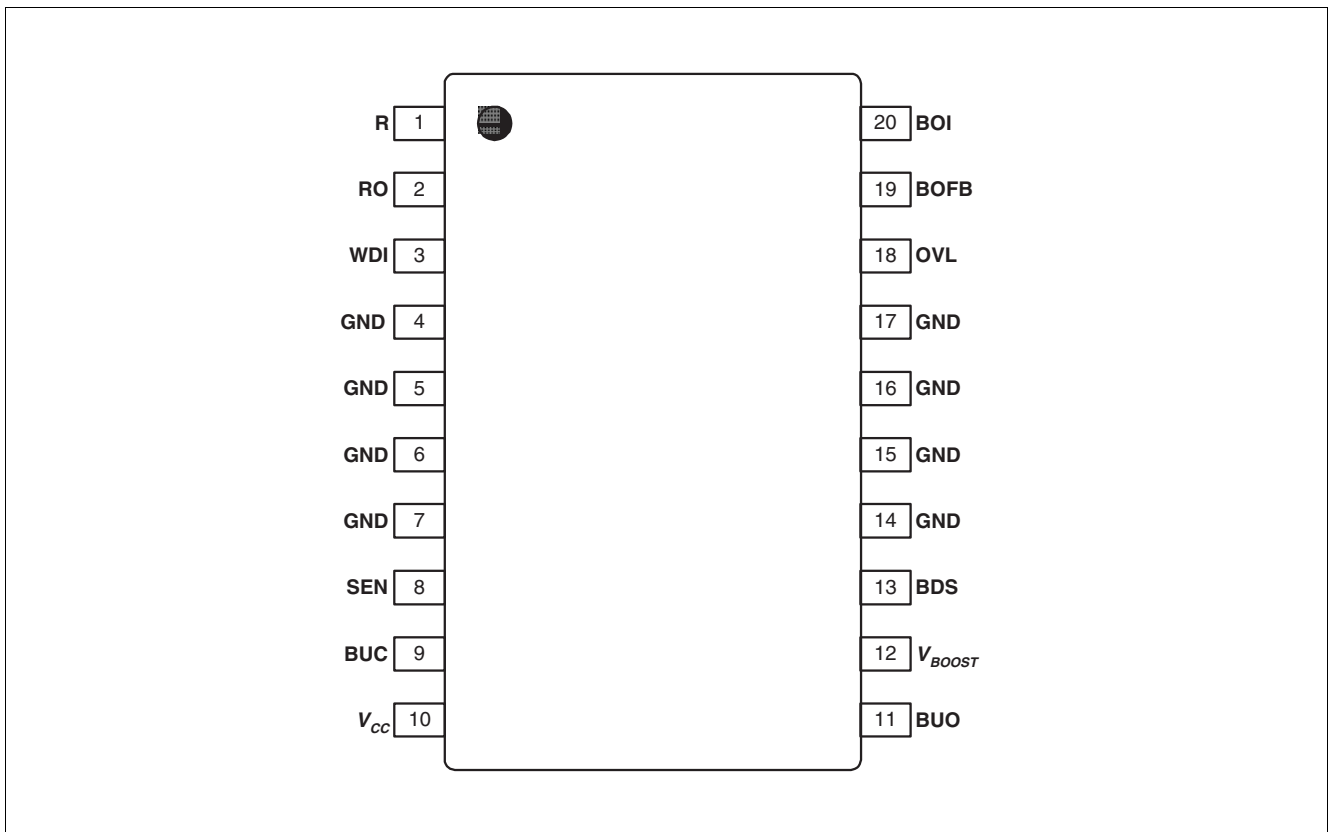

Figure 3 Pin Configuration PG-DSO-20-36 (top view)

## 2.2 Pin Definitions and Functions

Pin SO-14	Pin SO-20	Symbol	Function
1	1	R	<b>Reference Input;</b> an external resistor from this pin to GND determines the reference current and the oscillator frequency
2	2	RO	<b>Reset Output;</b> open drain output from reset comparator with an internal pull-up resistor
3	3	WDI	<b>Watchdog Input;</b> input for the watchdog control signal from the controller
4	4, 5, 6, 7, 14, 15, 16, 17	GND	<b>Ground;</b> analog signal ground
5	8	SEN	<b>System Enable Output;</b> open drain output from Watchdog fail-circuit with an internal pull-up resistor
6	9	BUC	<b>Buck-Converter Compensation Input;</b> output of internal error amplifier; for loop-compensation connect an external <i>R-C</i> -series combination to GND
7	10	$V_{CC}$	<b>Supply Voltage Output;</b> buck converter output; external blocking capacitor necessary
8	11	BUO	<b>Buck Converter Output;</b> source of the integrated power-DMOS
9	12	$V_{BOOST}$	<b>Boost Converter Input;</b> input supply voltage of the IC; coming from the boost converter output voltage; buck converter input voltage
10	13	BDS	<b>Buck Driver Supply Input;</b> voltage to drive the buck converter powerstage
11	18	OVL	<b>Boost Status Output;</b> open drain output from boost PWM comparator
12	19	BOFB	<b>Boost Converter Feedback Input;</b> connect boost voltage divider to this pin; internal reference is the boost feedback threshold $V_{BOFBTH}$
13	–	BOGND	<b>Boost-Ground;</b> power signal ground; source of boost converter power-DMOS
14	20	BOI	<b>Boost Converter Input;</b> drain of the integrated buck converter power-DMOS

### 3 General Product Characteristics

#### 3.1 Absolute Maximum Ratings

##### Absolute Maximum Ratings <sup>1)</sup>

$T_j = -40\text{ °C}$  to  $+150\text{ °C}$ ; all voltages with respect to ground, positive current flowing into pin (unless otherwise specified)

Pos.	Parameter	Symbol	Limit Values		Unit	Conditions
			Min.	Max.		
<b>Voltages</b>						
3.1.1	Boost input voltage	$V_{BOI}$	-0.3	46	V	–
3.1.2	Boost output voltage	$V_{BOOST}$	-0.3	46	V	–
3.1.3	Boost feedback voltage	$V_{BOFB}$	-0.3	46	V	–
3.1.4	Buck output voltage	$V_{BUO}$	-1	46	V	–
3.1.5	Buck driver supply voltage	$V_{BDS}$	-0.3	48	V	$0\text{ °C} < T_j \leq 150\text{ °C}$
3.1.6				47	V	$-40\text{ °C} \leq T_j \leq 0\text{ °C}$
3.1.7	Buck compensation input voltage	$V_{BUC}$	-0.3	6.8	V	–
3.1.8	Logic supply voltage	$V_{CC}$	-0.3	6.8	V	–
3.1.9	Reset output voltage	$V_{RO}$	-0.3	6.8	V	–
3.1.10	System Enable output voltage	$V_{SEN}$	-0.3	6.8	V	–
3.1.11	Current reference voltage	$V_R$	-0.3	6.8	V	–
3.1.12	Watchdog input voltage	$V_{WDI}$	-0.3	6.8	V	–
3.1.13	OVL output voltage	$V_{OVL}$	-0.3	6.8	V	–
<b>Temperatures</b>						
3.1.14	Junction Temperature	$T_j$	-40	150	°C	–
3.1.15	Storage Temperature	$T_{stg}$	-50	150	°C	–
<b>ESD Susceptibility</b>						
3.1.16	All pins to GND	$V_{HBM}$	-2	2	kV	Human Body Model; $R = 1.5\text{ k}\Omega$ ; $C = 100\text{ pF}$

1) Not subject to production test, specified by design.

**Attention: Stresses above the ones listed here may cause permanent damage to the device. Exposure to absolute maximum rating conditions for extended periods may affect device reliability.**

**Attention: Integrated protection functions are designed to prevent IC destruction under fault conditions described in the data sheet. Fault conditions are considered as “outside” normal operating range. Protection functions are not designed for continuous repetitive operation.**

### 3.2 Operating Range

Pos.	Parameter	Symbol	Limit Values		Unit	Conditions
			Min.	Max.		
3.2.1	Boost input voltage	$V_{BOI}$	-0.3	40	V	–
3.2.2	Boost input voltage; (normal operation)	$V_{BOOST}$	5	35	V	$V_{BOOST}$ increasing
3.2.3	Boost input voltage; (normal operation)	$V_{BOOST}$	4.5	36	V	$V_{BOOST}$ decreasing
3.2.4	Boost input voltage	$V_{BOOST}$	-0.3	4.5	V	Boost- and Buck- Converter OFF
3.2.5	Boost feedback voltage	$V_{BOFB}$	0	3.0	V	–
3.2.6	Buck output voltage	$V_{BUO}$	-0.6	40	V	–
3.2.7	Buck driver supply voltage	$V_{BDS}$	-0.3	48	V	$0\text{ °C} < T_j \leq 150\text{ °C}$
3.2.8				47	V	$-40\text{ °C} \leq T_j \leq 0\text{ °C}$
3.2.9	Buck compensation input voltage	$V_{BUC}$	0	3.0	V	–
3.2.10	Logic supply voltage	$V_{CC}$	4.00	6.25	V	–
3.2.11	Reset output voltage	$V_{RO}$	-0.3	$V_{CC} + 0.3$	V	–
3.2.12	System Enable output voltage	$V_{SEN}$	-0.3	$V_{CC} + 0.3$	V	–
3.2.13	Watchdog input voltage	$V_{WDI}$	0	$V_{CC} + 0.3$	V	–
3.2.14	Current reference voltage	$V_R$	0	3.0	V	–
3.2.15	Junction temperature	$T_j$	-40	150	°C	–
<b>Thermal Resistance</b>						
3.2.16	Junction ambient PG-DSO-14-1	$R_{thj-a}$	–	120	K/W	–
3.2.17	Junction ambient PG-DSO-20-36	$R_{thj-a}$	–	65	K/W	–

Note: In the operating range, the functions given in the circuit description are fulfilled.

## 4 Circuit Description

Below some important sections of the TLE 6711 G/GL are described in more detail.

### 4.1 Power On Reset

In order to avoid any system failure, a sequence of several conditions has to be passed. In case of  $V_{CC}$  power down ( $V_{CC} < V_{RT}$  for  $t > t_{RR}$ ) a logic LOW signal is generated at the pin RO to reset an external microcontroller. When the level of  $V_{CC}$  reaches the reset threshold  $V_{RT}$ , the signal at RO remains LOW for the Power-up reset delay time  $t_{RD}$  before switching to HIGH. If  $V_{CC}$  drops below the reset threshold  $V_{RT}$  for a time extending the reset reaction time  $t_{RR}$ , the reset circuit is activated and a power down sequence of period  $t_{RD}$  is initiated. The reset reaction time  $t_{RR}$  avoids wrong triggering caused by short “glitches” on the  $V_{CC}$ -line.

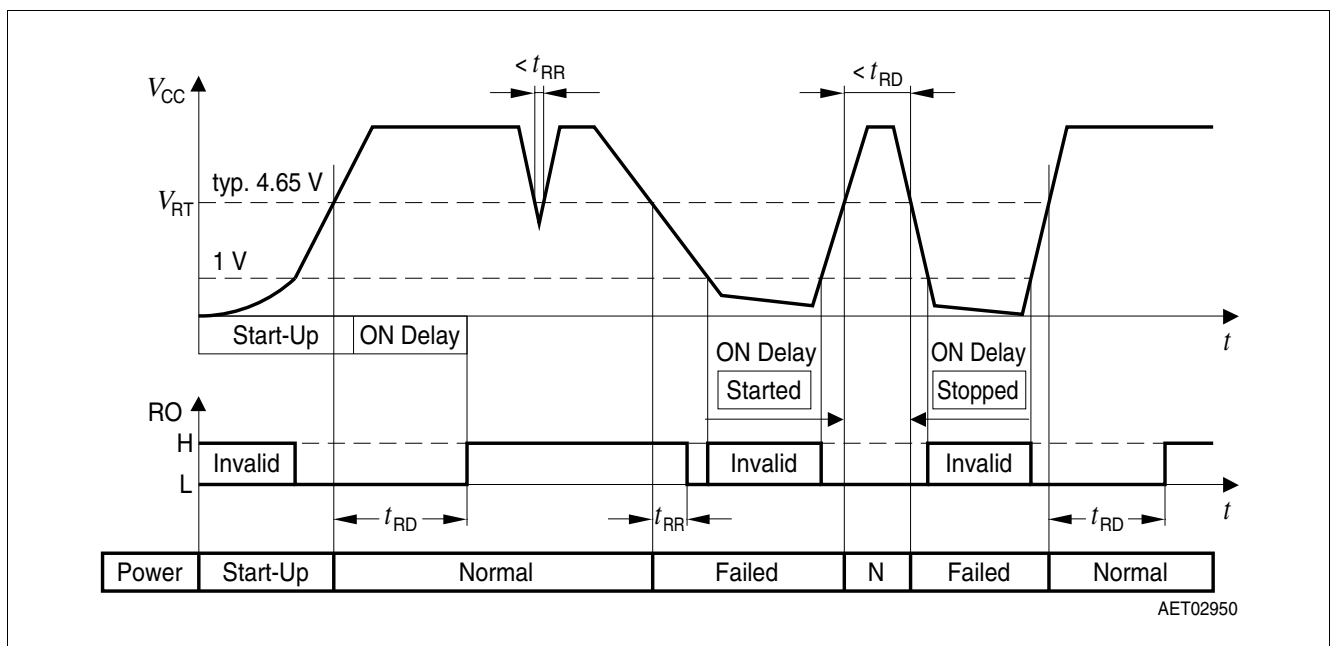

Figure 4 Reset Function

### 4.2 Watchdog Operation

The watchdog uses one hundred of the oscillator’s clock signal period as a timebase, defined as the watchdog cycle time  $t_{CYL}$ .

After power-on, the reset output signal at the RO pin (microcontroller reset) is kept LOW for the reset delay time  $t_{RD}$ , i.e. 64 cycles. With the LOW to HIGH transition of the signal at RO the device starts the closed window time  $t_{CW} = 32$  cycles. A trigger signal within this window is interpreted as a pretrigger failure according to the figures shown below. After the closed window the open window with the duration  $t_{OW}$  is started. The open window lasts at minimum until the trigger process has occurred, at maximum  $t_{OW}$  is 32 cycles.

A HIGH to LOW transition of the watchdog trigger signal on pin WDI is taken by a trigger. To avoid wrong triggering due to parasitic glitches two HIGH samples followed by two LOW samples (sample period  $t_{CYL}$ ) are decoded as a valid trigger. If a trigger signal appears at the watchdog input pin WDI during the open window or a power up/down occurs, the watchdog window signal is reset and a new closed window follows.

A reset is generated (RO goes LOW) if there is no trigger pulse during the open window or if a pretrigger occurs during the closed window. This reset happens after 64 cycles after the latest valid closed window start time and lasts for further 64 cycles.

The triggering is correct also, if the first three samples (two HIGH one LOW) of the trigger pulse at pin WDI are inside the closed window and only the fourth sample (the second LOW sample) is taken in the open window.

In addition to the microcontroller reset signal RO the device generates a system enable signal at pin SEN. If RO



is HIGH the system enable goes active HIGH with the first valid watchdog trigger pulse at pin WDI. The SEN output goes LOW immediately if a pretrigger, a missing trigger or a power down reset occurs.

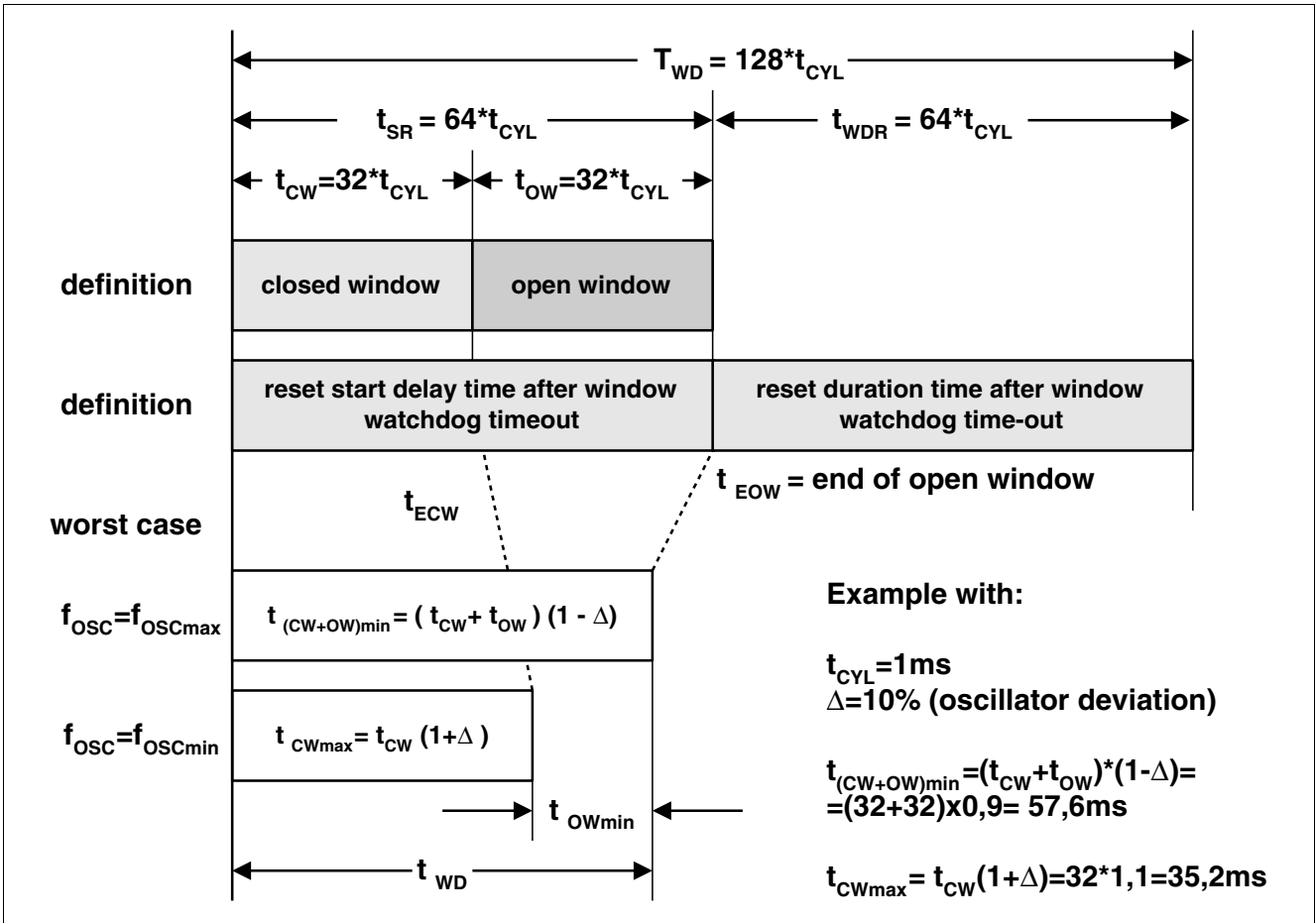

Figure 5 Window Watchdog Definitions 1

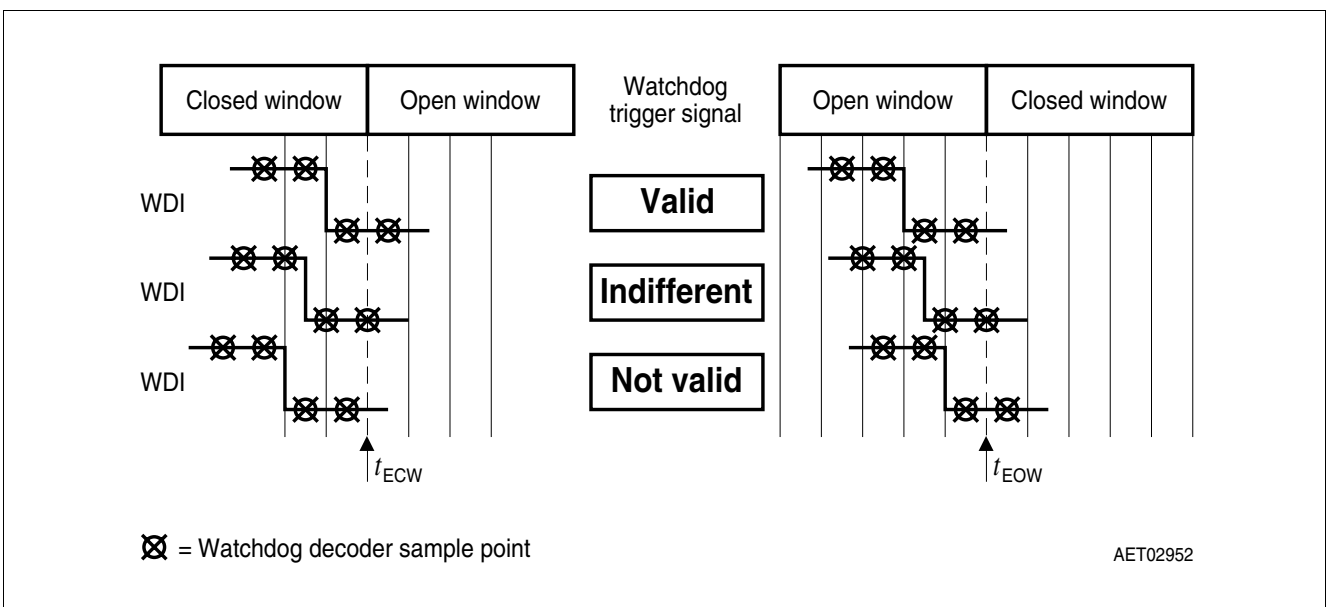

Figure 6 Window Watchdog Definitions 2

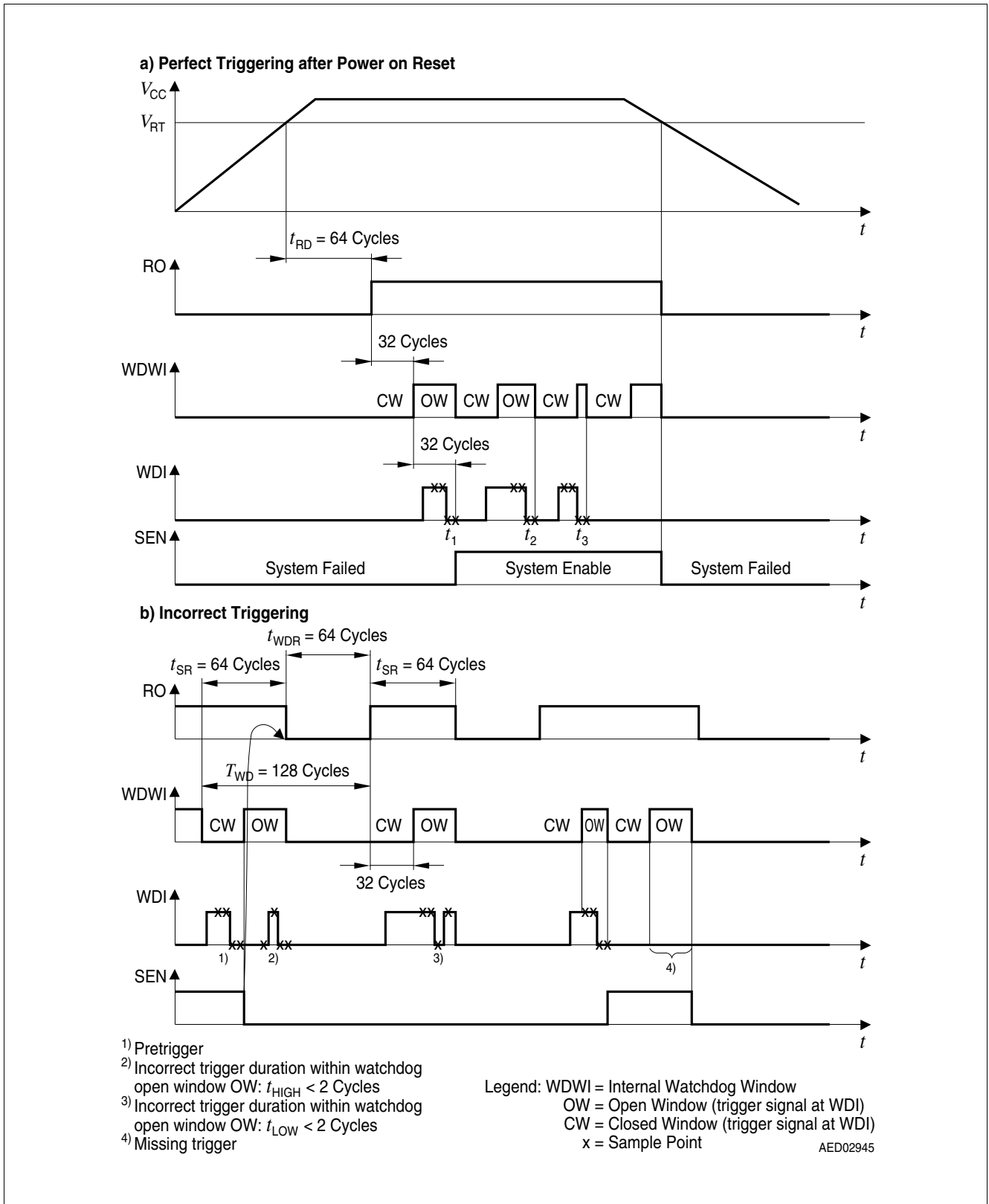

Figure 7 Window Watchdog Function

### 4.3 Boost Converter

The TLE 6711 G/GL contains a fully integrated boost converter (except the boost-diode), which provides a supply voltage for an energy reserve e.g. an airbag firing system. The regulated boost output voltage  $V_{BOOST}$  is programmable by a divider network (external resistors) providing the feedback voltage for the boost feedback pin BOFB. The energy which is stored in the external electrolytic capacitor at  $V_{BOOST}$  guarantees accurate airbag firing, even if the battery is disconnected by a car crash.

The boost inductance  $L_{BO}$  (typ. 100  $\mu$ H) is PWM-switched by an integrated current limited power DMOS transistor with a programmable (external resistor  $R_R$ ) frequency.

An internal bandgap reference provides a temperature independent, on chip trimmed reference voltage for the regulation loop. An error amplifier compares the reference voltage with the boost feedback signal  $V_{BOFB}$  from the external divider network (determination of the output boost voltage  $V_{BOOST}$ ).

Application note for programming the output voltage at pin  $V_{BOOST}$ :

$$V_{BOOST} = V_{BOFBTH} \times \frac{(R_{BO1} + R_{BO2})}{R_{BO2}} \tag{1}$$

With a PWM (Pulse Width Modulation) comparator the output of the error amplifier is compared to a periodic linear ramp, provided by a sawtooth signal of the oscillator connected to pin R. A logic signal with variable pulse width is generated. It passes through the logic circuits (sets the output latch PWM-FF) and driver circuits to the power switching DMOS. The Schmitt-trigger output resets the output flip-flop PWM-FF by NOR 2. The PWM signal is gated by the NAND 2 to guarantee a dominant reset.

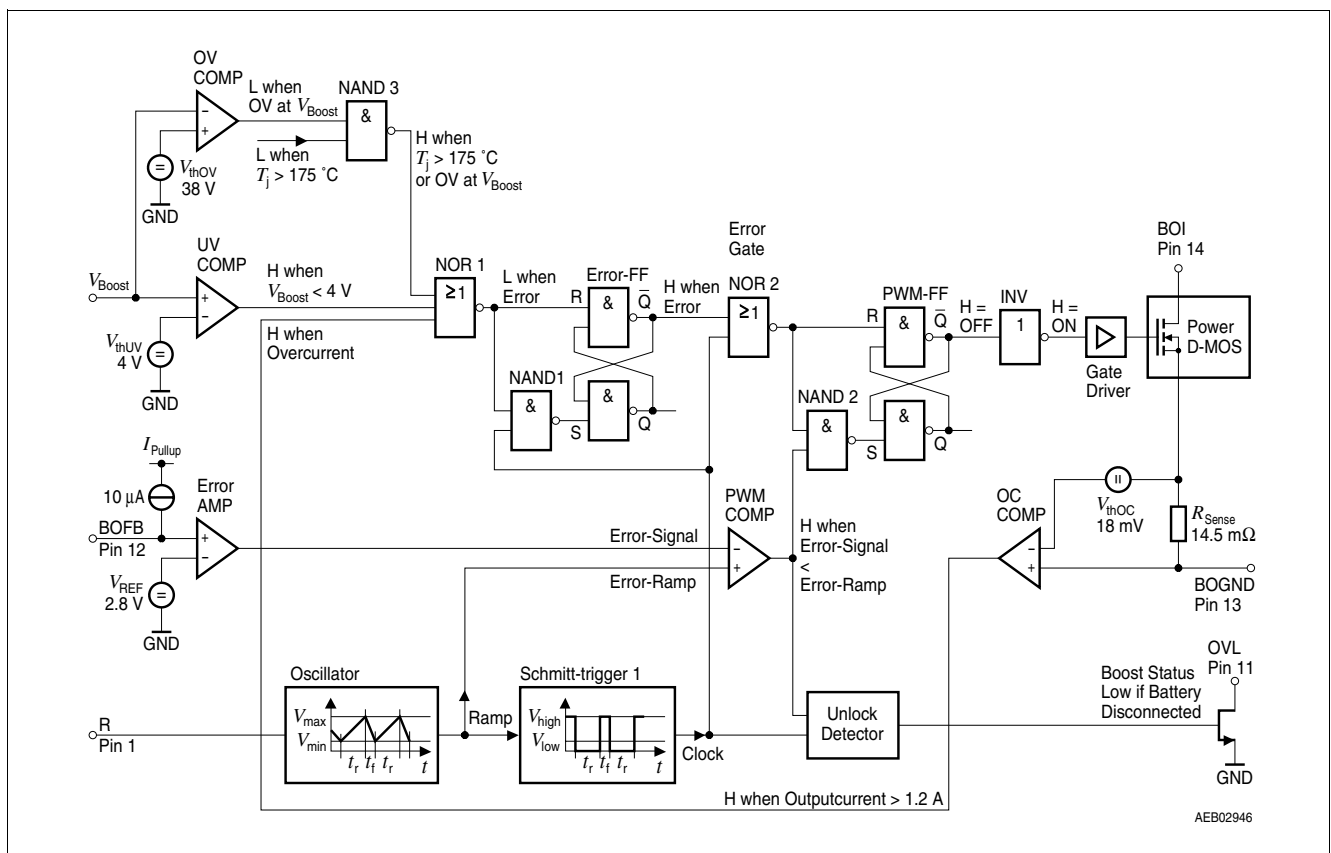

Figure 8 Boost Converter Block Diagram

Figure 8 shows the most important waveforms during operation; for low, medium and high loads up to overload condition. The output transistor is switched off immediately if the overcurrent comparator detects an overcurrent level at the power DMOS or if the sense output switches to low induced by a  $V_{BOOST}$  undervoltage command.

The TLE 6711 G/GL is also protected against several boost loop errors:

In case of a feedback interruption a pull-up current source ( $I_{FB}$  typ.  $0.4 \mu A$ ), integrated at pin BOFB pulls the voltage at the feedback pin BOFB above the reference voltage. The boost output is switched off by the high error voltage which controls the PWM-Comparator at a zero duty cycle.

In the case of a resistive loop error caused by leakage currents to ground, the boost output voltage would increase to very high values. In order to protect the  $V_{BOOST}$  input as well as the external load against catastrophic failures, an overvoltage protection is provided which switches the output transistor off as soon as the voltage at pin  $V_{BOOST}$  exceeds the internal fixed overvoltage threshold  $V_{BOOV OFF} = \text{typ. } 37 V$ .

**Application Note**

A short circuit from  $V_{BOOST}$  to ground will not destroy the IC, however, it may damage the external boost diode or the boost inductance if there is no overcurrent limitation in that path.

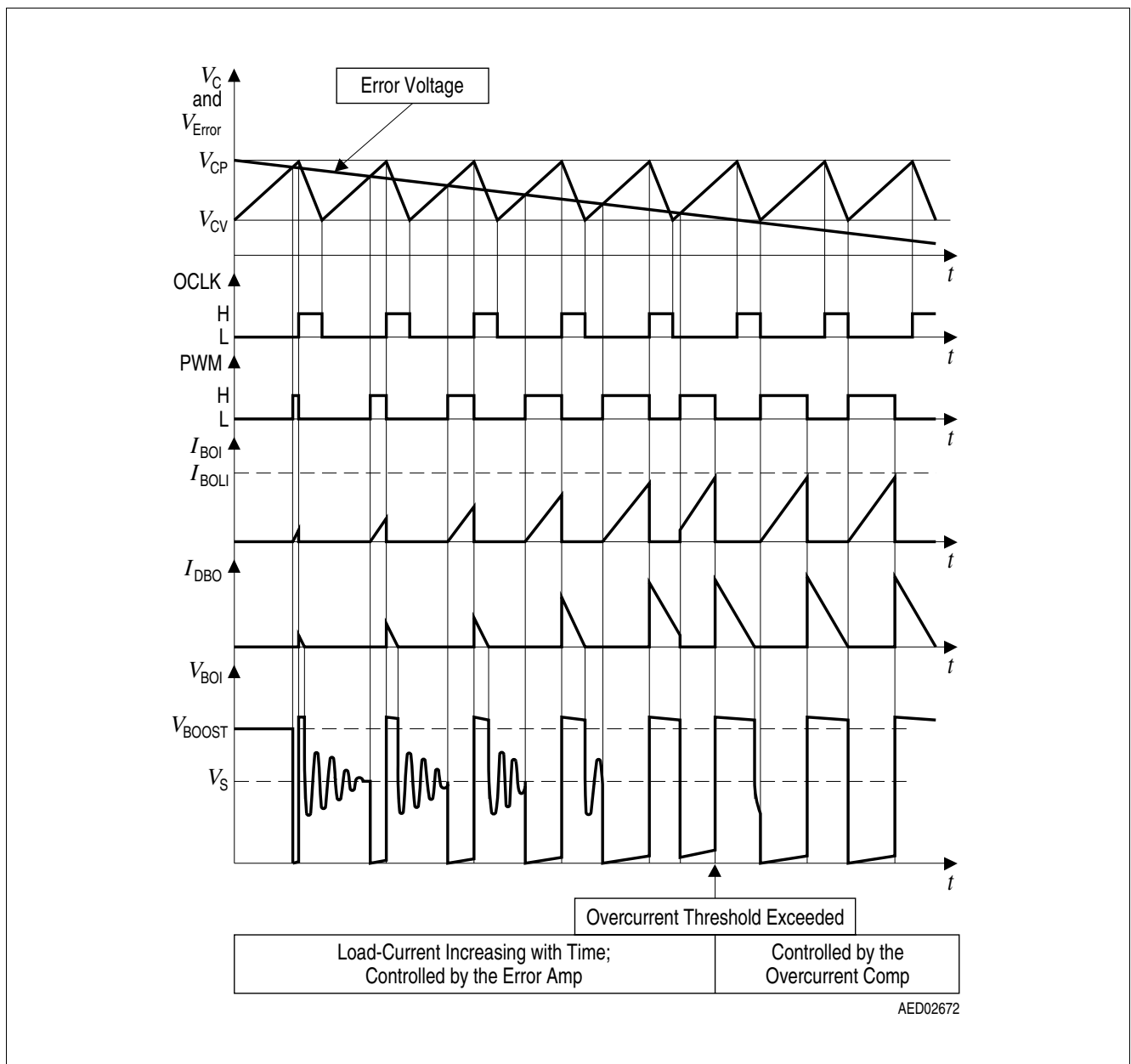

**Figure 9 Most Important Waveforms of the Boost Converter Circuit**

### 4.3.1 Boost Status Output OVL

For supervision of the Boost output voltage an open drain DMOS output is used. The output is high impedance in normal operation and low during the warning.

The OVL goes LOW if the PWM comparator output (see **Figure 8**) remains HIGH for clock time period. This occurs when the Error-Signal falls below the minimum value of the Error-Ramp, this mean that Boost voltage falls below a certain threshold voltage.

The OVL output used as a warning for insufficient Boost voltage.

### 4.4 Buck Converter

A stabilized logic supply voltage (typ. 5 V) for general purpose is realized in the system by a buck converter. An external buck-inductance  $L_{BU}$  is PWM switched by a high side DMOS power transistor with the programmed frequency (pin R).

The buck regulator supply is given by the boost converter output  $V_{BOOST}$ , in case of a battery power-down the stored energy of the boost converter capacitor is used.

Like the boost converter, the buck converter uses the temperature compensated bandgap reference voltage (typ. 2.8 V) for its regulation loop.

This reference voltage is connected to the non-inverting input of the error amplifier and an internal voltage divider supplies the inverting input. Therefore the output voltage  $V_{CC}$  is fixed due to the internal resistor ratio to typ. 5.0 V. The output of the error amplifier goes to the inverting input of the PWM comparator as well as to the buck compensation output BUC.

When the error amplifier output voltage exceeds the sawtooth voltage the output power MOS-transistor is switched on. So the duration of the output transistor conduction phase depends on the  $V_{CC}$  level. A logic signal PWM with variable pulse width is generated.

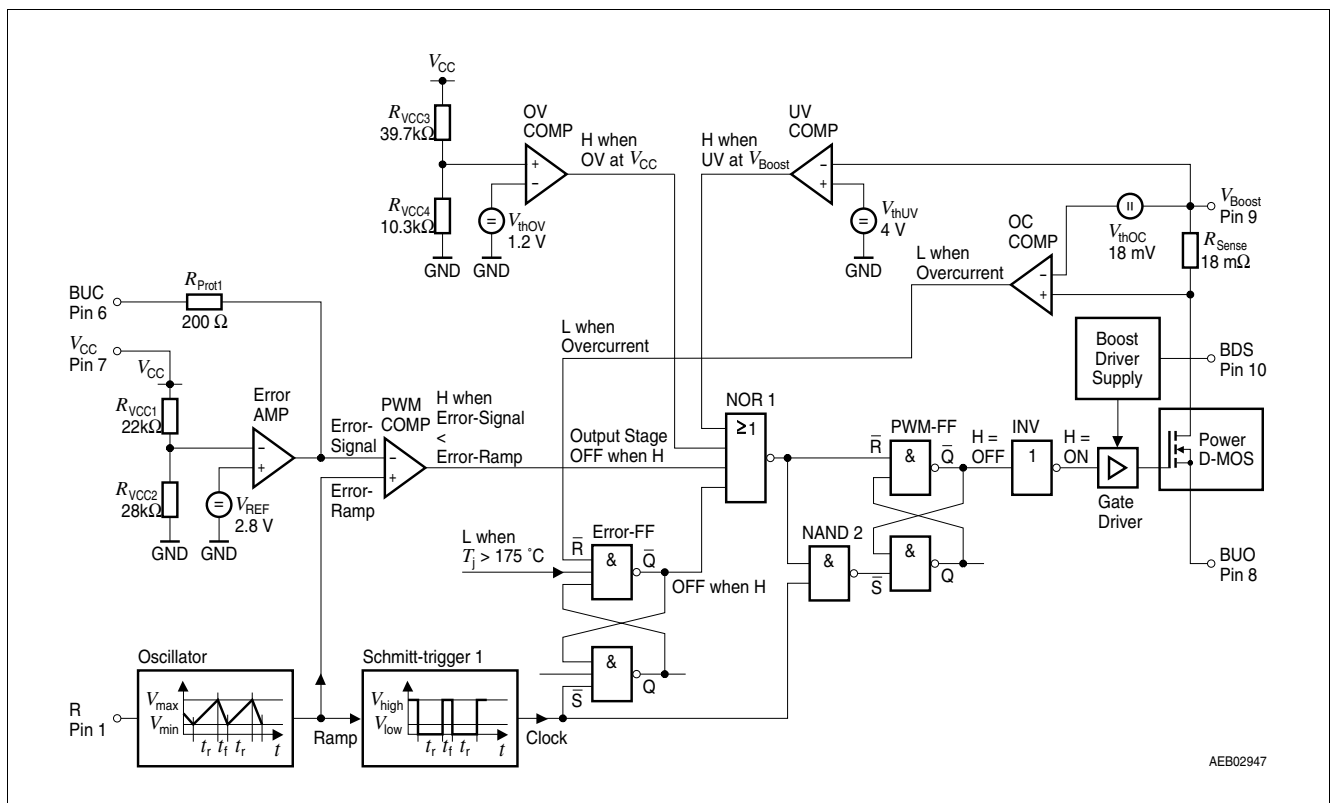

Figure 10 Buck Converter Block Diagram

Circuit Description

External loop compensation is required for converter stability, and is formed by connecting a compensation resistor-capacitor series-network ( $R_{BUC}$ ,  $C_{BUC}$ ) between pin BUC and GND.

In the case of overload or short-circuit at  $V_{CC}$  (the output current exceeds the buck overcurrent threshold  $I_{BUOC}$ ) the DMOS output transistor is switched off by the overcurrent comparator immediately. The pulse width is then controlled by the overcurrent comparator as seen before in the boost description.

In order to protect the  $V_{CC}$  input as well as the external load against catastrophic failures, an overvoltage protection is provided which switches the output transistor off as soon as the voltage at pin  $V_{CC}$  exceeds the internal fixed overvoltage threshold  $V_{BUOV\ OFF} = \text{typ. } 6.0 \text{ V}$ .

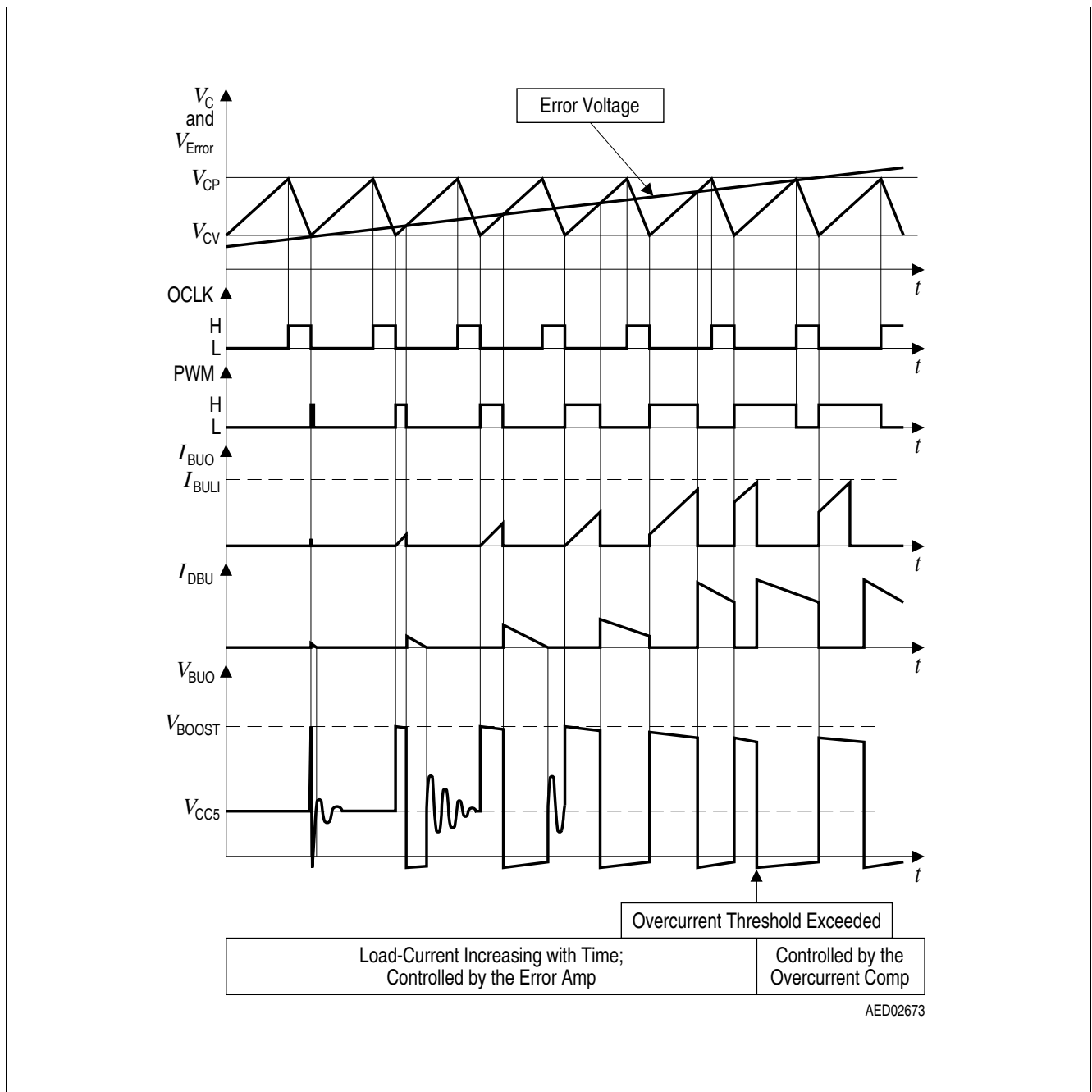

Figure 11 Most Important Waveforms of the Buck Converter Circuit

### 4.5 Electrical Characteristics

Note: The listed characteristics are ensured over the operating range of the integrated circuit. Typical characteristics specify mean values expected over the production spread. If not otherwise specified, typical characteristics apply at  $T_A = 25\text{ °C}$  and the given supply voltage.

#### Electrical Characteristics: Current Consumption

$V_{CC} = 4.75\text{ V to }5.25\text{ V}$ ;  $V_{Boost} = 8\text{ V to }35\text{ V}$ ,  $T_j = -40\text{ °C to }+150\text{ °C}$ ,  $R_R = 47\text{ k}\Omega$ ; all voltages with respect to ground, positive current flowing into pin (unless otherwise specified)

Pos.	Parameter	Symbol	Limit Values			Unit	Conditions
			Min.	Typ.	Max.		
4.5.1	Current consumption; see application circuit	$I_{Boost}$	–	1.5	4	mA	$I_{CC} = 0\text{ mA}$ ; $I_{BoLoad} = 0\text{ mA}$
4.5.2	Current consumption; see application circuit	$I_{Boost}$	–	5	10	mA	$I_{CC} = 200\text{ mA}$ ; $I_{BoLoad} = 50\text{ mA}$

#### Electrical Characteristics: Under- and Over-Voltage Lockout at $V_{Boost}$

$V_{CC} = 4.75\text{ V to }5.25\text{ V}$ ;  $V_{Boost} = 8\text{ V to }35\text{ V}$ ,  $T_j = -40\text{ °C to }+150\text{ °C}$ ,  $R_R = 47\text{ k}\Omega$ ; all voltages with respect to ground, positive current flowing into pin (unless otherwise specified)

Pos.	Parameter	Symbol	Limit Values			Unit	Conditions
			Min.	Typ.	Max.		
4.5.3	UV ON voltage; boost and buck conv. ON	$V_{BOUVON}$	4.0	4.5	5.0	V	$V_{Boost}$ increasing
4.5.4	UV OFF voltage; boost and buck conv. OFF	$V_{BOUVOFF}$	3.5	4.0	4.5	V	$V_{Boost}$ decreasing
4.5.5	UV Hysteresis voltage	$V_{BOUVHY}$	0.2	0.5	1.0	V	HY = ON - OFF
4.5.6	OV OFF voltage; boost conv. OFF	$V_{BOOVOFF}$	34	37	40	V	$V_{Boost}$ increasing
4.5.7	OV ON voltage; boost conv. ON	$V_{BOOVON}$	30	33	36	V	$V_{Boost}$ decreasing
4.5.8	OV Hysteresis voltage	$V_{BOUVHY}$	1.5	4	10	V	HY = OFF - ON

#### Electrical Characteristics: Over-Voltage Lockout at $V_{CC}$

$V_{CC} = 4.75\text{ V to }5.25\text{ V}$ ;  $V_{Boost} = 8\text{ V to }35\text{ V}$ ,  $T_j = -40\text{ °C to }+150\text{ °C}$ ,  $R_R = 47\text{ k}\Omega$ ; all voltages with respect to ground, positive current flowing into pin (unless otherwise specified)

Pos.	Parameter	Symbol	Limit Values			Unit	Conditions
			Min.	Typ.	Max.		
4.5.9	OV OFF voltage; buck conv. OFF	$V_{BUOVOFF}$	5.5	6.0	6.5	V	$V_{CC}$ increasing
4.5.10	OV ON voltage; buck conv. ON	$V_{BUOVON}$	5.25	5.75	6.25	V	$V_{CC}$ decreasing
4.5.11	OV Hysteresis voltage	$V_{BUOVHY}$	0.10	0.25	0.50	V	HY = OFF - ON

**Electrical Characteristics: Boost-Converter; BOI, BOFB and  $V_{\text{BOOST}}$** 

$V_{\text{CC}} = 4.75 \text{ V to } 5.25 \text{ V}$ ;  $V_{\text{Boost}} = 8 \text{ V to } 35 \text{ V}$ ,  $T_j = -40 \text{ }^\circ\text{C to } +150 \text{ }^\circ\text{C}$ ,  $R_R = 47 \text{ k}\Omega$ ; all voltages with respect to ground, positive current flowing into pin (unless otherwise specified)

Pos.	Parameter	Symbol	Limit Values			Unit	Conditions
			Min.	Typ.	Max.		
4.5.12	Boost voltage; see application circuit	$V_{\text{BOOST}}$	24.0	27.5	31.0	V	$5 \text{ mA} < I_{\text{BOOST}} < 100 \text{ mA}$ ; $T_j = 25 \text{ }^\circ\text{C}$ ; $8 \text{ V} < V_{\text{Batt}} < 16 \text{ V}$
4.5.13	Boost Voltage; see application circuit	$V_{\text{BOOST}}$	23	–	32	V	$5 \text{ mA} < I_{\text{BOOST}} < 100 \text{ mA}$ ; $8 \text{ V} < V_{\text{Batt}} < 16 \text{ V}$
4.5.14	Efficiency; see. appl. circuit	$\eta$	–	80	–	%	$I_{\text{BOOST}} = 100 \text{ mA}$
4.5.15	Power-Stage ON resistance	$R_{\text{BOON}}$	–	0.6	0.75	$\Omega$	$T_j = 25 \text{ }^\circ\text{C}$ ; $I_{\text{BOI}} = 1 \text{ A}$
4.5.16	Power-Stage ON resistance	$R_{\text{BOON}}$	–	–	1.4	$\Omega$	$I_{\text{BOI}} = 1 \text{ A}$
4.5.17	Boost overcurrent threshold	$I_{\text{BOOC}}$	1.0	1.3	1.8	A	–
4.5.18	Feedback threshold voltage	$V_{\text{BOFBTH}}$	2.55	2.7	2.85	V	$V_{\text{BOI}} = 12 \text{ V}$ ; $I_{\text{BOOST}} = 25 \text{ mA}$
4.5.19	Feedback input current	$I_{\text{FB}}$	-2	-0.4	0	$\mu\text{A}$	$2 \text{ V} < V_{\text{BOFB}} < 4 \text{ V}$

**Electrical Characteristics: Buck-Converter; BUO, BDS, BUC and  $V_{\text{CC}}$** 

$V_{\text{CC}} = 4.75 \text{ V to } 5.25 \text{ V}$ ;  $V_{\text{Boost}} = 8 \text{ V to } 35 \text{ V}$ ,  $T_j = -40 \text{ }^\circ\text{C to } +150 \text{ }^\circ\text{C}$ ,  $R_R = 47 \text{ k}\Omega$ ; all voltages with respect to ground, positive current flowing into pin (unless otherwise specified)

Pos.	Parameter	Symbol	Limit Values			Unit	Conditions
			Min.	Typ.	Max.		
4.5.20	Logic supply voltage	$V_{\text{CC}}$	4.9	–	5.1	V	$1 \text{ mA} < I_{\text{CC}} < 250 \text{ mA}$ ; see. appl. circuit
4.5.21	Efficiency; see. appl. circuit	$\eta$	–	85	–	%	$I_{\text{CC}} = 250 \text{ mA}$ ; $V_{\text{Boost}} = 25 \text{ V}$
4.5.22	Power-Stage ON resistance	$R_{\text{BUON}}$	–	0.38	0.5	$\Omega$	$T_j = 25 \text{ }^\circ\text{C}$ ; $I_{\text{BUO}} = 1 \text{ A}$
4.5.23	Power-Stage ON resistance	$R_{\text{BUON}}$	–	–	1.0	$\Omega$	$I_{\text{BUO}} = 1 \text{ A}$
4.5.24	Buck overcurrent threshold	$I_{\text{BUOC}}$	0.7	0.95	1.2	A	–
4.5.25	Input current on pin $V_{\text{CC}}$	$I_{\text{CC}}$	–	0.2	0.5	mA	$V_{\text{CC}} = 5 \text{ V}$
4.5.26	Buck Gate supply voltage; $V_{\text{BGS}} = V_{\text{BDS}} - V_{\text{BOOST}}$	$V_{\text{BGS}}$	5	–	10	V	–



**Electrical Characteristics: Reference Input; R  
(Oscillator; Timebase for Boost- and Buck-Converter, Reset and Watchdog)**

$V_{CC} = 4.75 \text{ V to } 5.25 \text{ V}$ ;  $V_{Boost} = 8 \text{ V to } 35 \text{ V}$ ,  $T_j = -40 \text{ }^\circ\text{C to } +150 \text{ }^\circ\text{C}$ ,  $R_R = 47 \text{ k}\Omega$ ; all voltages with respect to ground, positive current flowing into pin (unless otherwise specified)

Pos.	Parameter	Symbol	Limit Values			Unit	Conditions
			Min.	Typ.	Max.		
4.5.27	Voltage on pin R	$V_R$	1.3	1.4	1.5	V	–
4.5.28	Oscillator frequency	$f_{OSC}$	85	95	105	kHz	$T_j = 25 \text{ }^\circ\text{C}$
4.5.29	Oscillator frequency	$f_{OSC}$	75	–	115	kHz	–
4.5.30	Cycle time for watchdog and reset timing	$t_{CYL}$	–	1.05	–	ms	$t_{CYL} = 100/f_{OSC}$

**Electrical Characteristics: Reset Generator; RO**

$V_{CC} = 4.75 \text{ V to } 5.25 \text{ V}$ ;  $V_{Boost} = 8 \text{ V to } 35 \text{ V}$ ,  $T_j = -40 \text{ }^\circ\text{C to } +150 \text{ }^\circ\text{C}$ ,  $R_R = 47 \text{ k}\Omega$ ; all voltages with respect to ground, positive current flowing into pin (unless otherwise specified)

Pos.	Parameter	Symbol	Limit Values			Unit	Conditions
			Min.	Typ.	Max.		
4.5.31	Reset threshold; $V_{CC}$ decreasing/increasing	$V_{RT}$	4.50	4.65	4.75	V	$V_{RO}$ H to L or L to H transition; $V_{RO}$ remains low down to $V_{CC} > 1 \text{ V}$
4.5.32	Reset low voltage	$V_{ROL}$	–	0.2	0.4	V	$I_{ROL} = 2 \text{ mA}$ ; $2.5 \text{ V} < V_{CC} < V_{RT}$
4.5.33	Reset low voltage	$V_{ROL}$	–	0.2	0.4	V	$I_{ROL} = 0.2 \text{ mA}$ ; $1 \text{ V} < V_{CC} < V_{RT}$
4.5.34	Reset high voltage	$V_{ROH}$	$V_{CC} - 0.1$	–	$V_{CC} + 0.1$	V	$I_{ROH} = 0 \text{ mA}$
4.5.35	Reset pull-up current	$I_{RO}$	–	240	–	$\mu\text{A}$	$0 \text{ V} < V_{RO} < 4 \text{ V}$
4.5.36	Reset Reaction time	$t_{RR}$	50	100	150	$\mu\text{s}$	$V_{CC} < V_{RT}$
4.5.37	Power-up reset delay time	$t_{RD}$	–	64	–	$t_{CYL}$	$V_{CC} \geq 4.8 \text{ V}$

**Electrical Characteristics: Watchdog Generator; WDI**

$V_{CC} = 4.75 \text{ V to } 5.25 \text{ V}$ ;  $V_{Boost} = 8 \text{ V to } 35 \text{ V}$ ,  $T_j = -40 \text{ }^\circ\text{C to } +150 \text{ }^\circ\text{C}$ ,  $R_R = 47 \text{ k}\Omega$ ; all voltages with respect to ground, positive current flowing into pin (unless otherwise specified)

Pos.	Parameter	Symbol	Limit Values			Unit	Conditions
			Min.	Typ.	Max.		
4.5.38	H-input voltage threshold	$V_{WDIH}$	–	–	$0.7 \times V_{CC}$	V	–
4.5.39	L-input voltage threshold	$V_{WDIL}$	$0.3 \times V_{CC}$	–	–	V	–
4.5.40	Watchdog period	$T_{WD}$	–	128	–	$t_{CYL}$	$V_{CC} \geq 4.8 \text{ V}$
4.5.41	Start of reset; after watchdog time-out	$t_{SR}$	–	64	–	$t_{CYL}$	$V_{CC} \geq 4.8 \text{ V}$

**Electrical Characteristics: Watchdog Generator; WDI (cont'd)**

$V_{CC} = 4.75 \text{ V to } 5.25 \text{ V}$ ;  $V_{Boost} = 8 \text{ V to } 35 \text{ V}$ ,  $T_j = -40 \text{ }^\circ\text{C to } +150 \text{ }^\circ\text{C}$ ,  $R_R = 47 \text{ k}\Omega$ ; all voltages with respect to ground, positive current flowing into pin (unless otherwise specified)

Pos.	Parameter	Symbol	Limit Values			Unit	Conditions
			Min.	Typ.	Max.		
4.5.42	Reset duration; after watchdog time-out	$t_{WDR}$	–	64	–	$t_{CYL}$	$V_{CC} \geq 4.8 \text{ V}$
4.5.43	Open window time	$t_{OW}$	–	32	–	$t_{CYL}$	$V_{CC} \geq 4.8 \text{ V}$
4.5.44	Closed window time	$t_{CW}$	–	32	–	$t_{CYL}$	$V_{CC} \geq 4.8 \text{ V}$
4.5.45	Window watchdog trigger time	$t_{WD}$	–	46.4	–	$t_{CYL}$	$V_{CC} \geq 4.8 \text{ V}$

**Electrical Characteristics: System Enable Output; SEN**

$V_{CC} = 4.75 \text{ V to } 5.25 \text{ V}$ ;  $V_{Boost} = 8 \text{ V to } 35 \text{ V}$ ,  $T_j = -40 \text{ }^\circ\text{C to } +150 \text{ }^\circ\text{C}$ ,  $R_R = 47 \text{ k}\Omega$ ; all voltages with respect to ground, positive current flowing into pin (unless otherwise specified)

Pos.	Parameter	Symbol	Limit Values			Unit	Conditions
			Min.	Typ.	Max.		
4.5.46	Enable low voltage	$V_{SENL}$	–	0.2	0.4	V	$I_{SENL} = 2 \text{ mA}$ ; $2.5 \text{ V} < V_{CC} < V_{RT}$
4.5.47	Enable low voltage	$V_{SENL}$	–	0.2	0.4	V	$I_{SENL} = 0.2 \text{ mA}$ ; $1 \text{ V} < V_{CC} < V_{RT}$
4.5.48	Enable high voltage	$V_{SENH}$	$V_{CC} - 0.1$	–	$V_{CC} + 0.1$	V	$I_{SENH} = 0 \text{ mA}$
4.5.49	Enable pull-up current	$I_{SEN}$	–	240	–	$\mu\text{A}$	$0 \text{ V} < V_{SEN} < 4 \text{ V}$

**Electrical Characteristics: Boost Status Output; OVL**

$V_{CC} = 4.75 \text{ V to } 5.25 \text{ V}$ ;  $V_{Boost} = 8 \text{ V to } 35 \text{ V}$ ,  $T_j = -40 \text{ }^\circ\text{C to } +150 \text{ }^\circ\text{C}$ ,  $R_R = 47 \text{ k}\Omega$ ; all voltages with respect to ground, positive current flowing into pin (unless otherwise specified)

Pos.	Parameter	Symbol	Limit Values			Unit	Conditions
			Min.	Typ.	Max.		
4.5.50	Enable low voltage	$V_{OVLL}$	–	0.2	0.4	V	$I_{OVLL} = 1 \text{ mA}$ ; $2.5 \text{ V} < V_{CC} < V_{RT}$
4.5.51	Boost feedback threshold voltage	$V_{OVLTH}$	2.3	2.45	2.6	V	See application circuit

**Electrical Characteristics: Thermal Shutdown (Boost and Buck-Converter OFF)**

$V_{CC} = 4.75 \text{ V to } 5.25 \text{ V}$ ;  $V_{Boost} = 8 \text{ V to } 35 \text{ V}$ ,  $T_j = -40 \text{ }^\circ\text{C to } +150 \text{ }^\circ\text{C}$ ,  $R_R = 47 \text{ k}\Omega$ ; all voltages with respect to ground, positive current flowing into pin (unless otherwise specified)

Pos.	Parameter	Symbol	Limit Values			Unit	Conditions
			Min.	Typ.	Max.		
4.5.52	Thermal shutdown junction temperature	$T_{jSD}$	150	175	200	$^\circ\text{C}$	–
4.5.53	Thermal switch-on junction temperature	$T_{jSO}$	120	–	170	$^\circ\text{C}$	–
4.5.54	Temperature hysteresis	$\Delta T$	–	30	–	K	–

## 5 Application Information

Note: The following information is given as a hint for the implementation of the device only and shall not be regarded as a description or warranty of a certain functionality, condition or quality of the device.

Figure 12 shows the application circuit of the TLE 6711 G/GL with the suggested external parts.

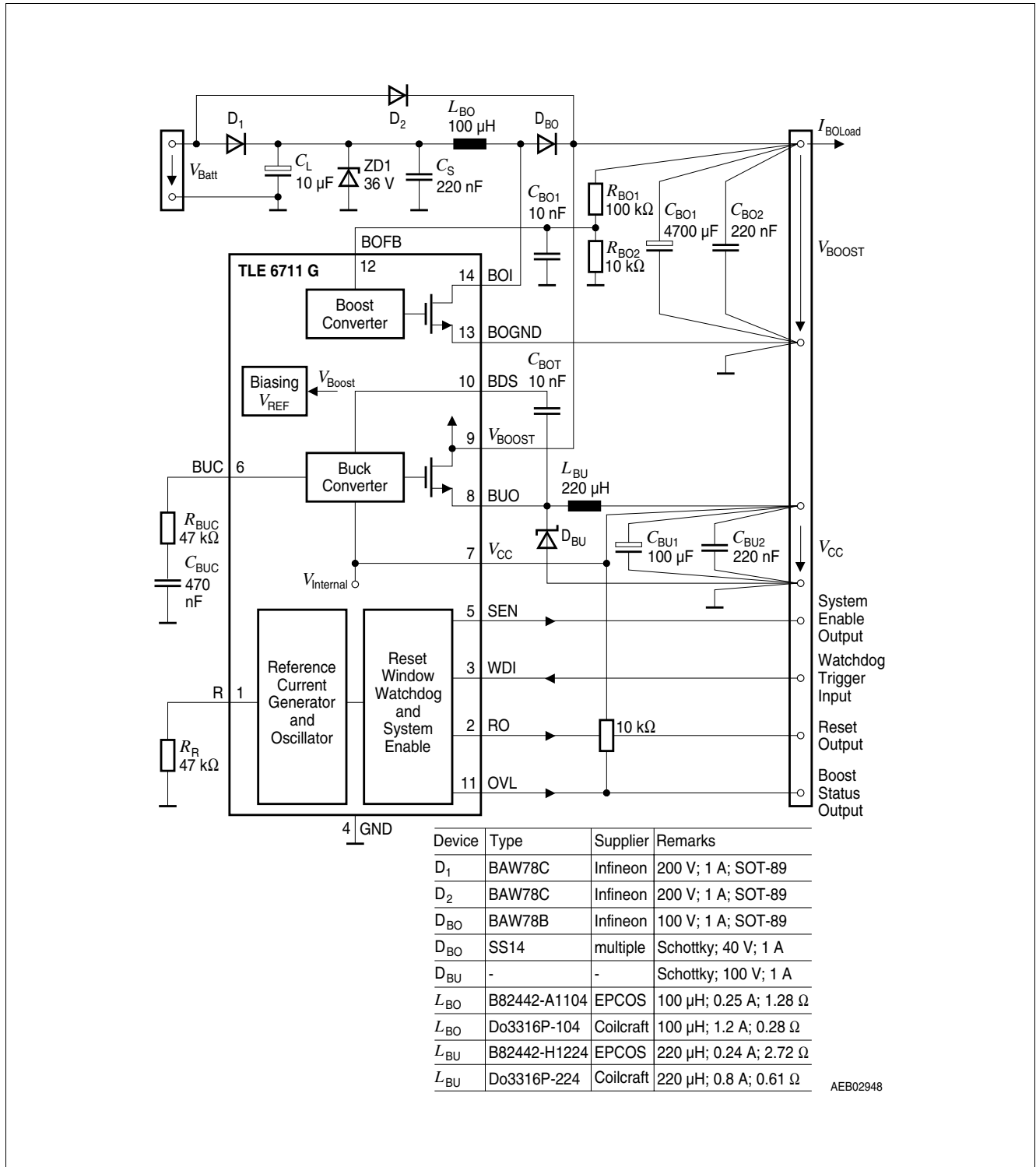
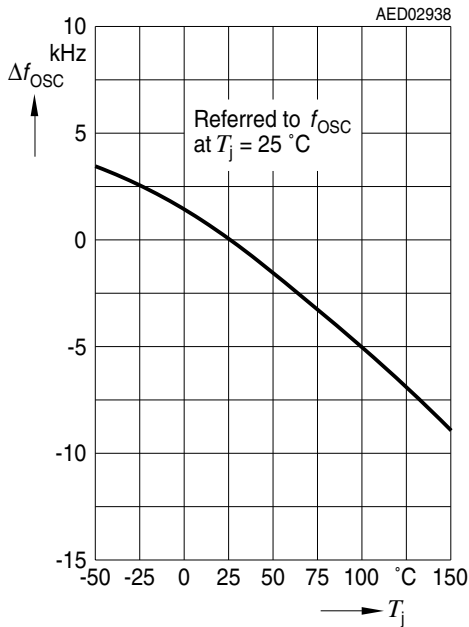

Figure 12 Application Circuit (pinning valid for PG-DSO-14-1)

## 6 Diagrams: Oscillator and Boost/Buck-Converter Performance

In the following the behaviour of the Boost/Buck-converter and the oscillator is shown.

**Oscillator Frequency Deviation vs. Junction Temperature**



**Boost Feedback Current vs. Junction Temperature**

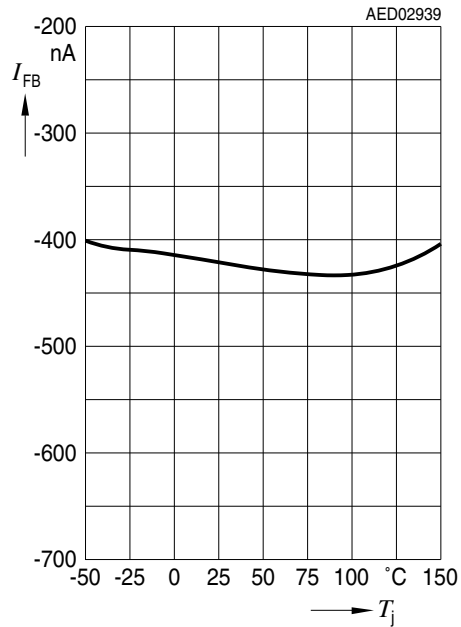

**Current Consumption vs. Junction Temperature**

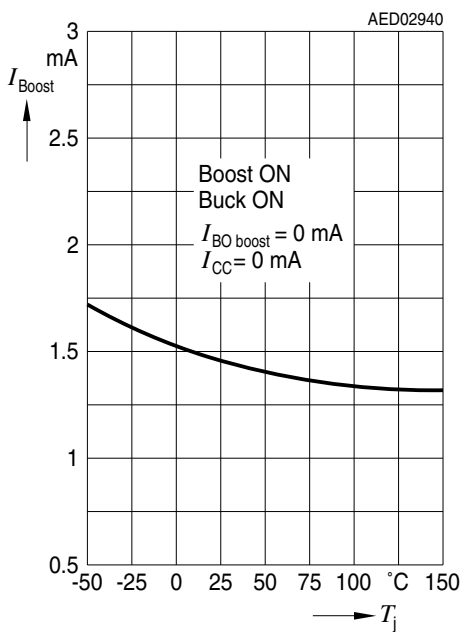

**Efficiency Buck vs. Load**

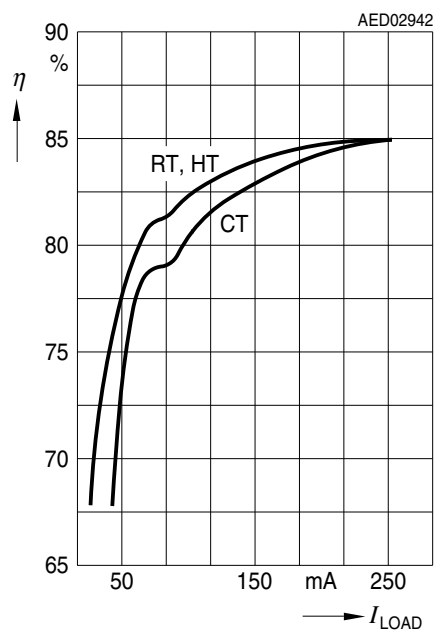

Diagrams: Oscillator and Boost/Buck-Converter Performance

**Efficiency Buck vs. Boost Voltage**

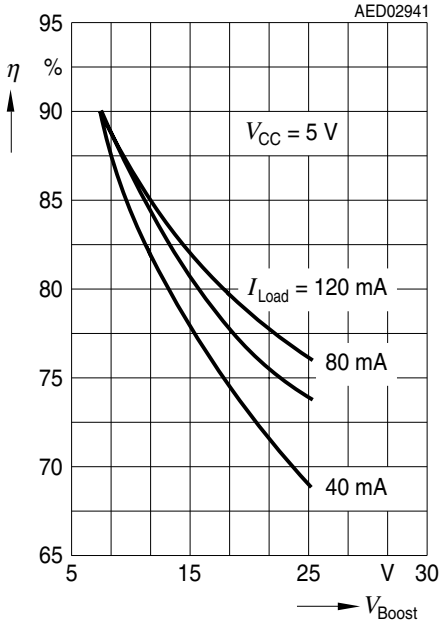

**Oscillator Frequency vs. Resistor from R to GND**

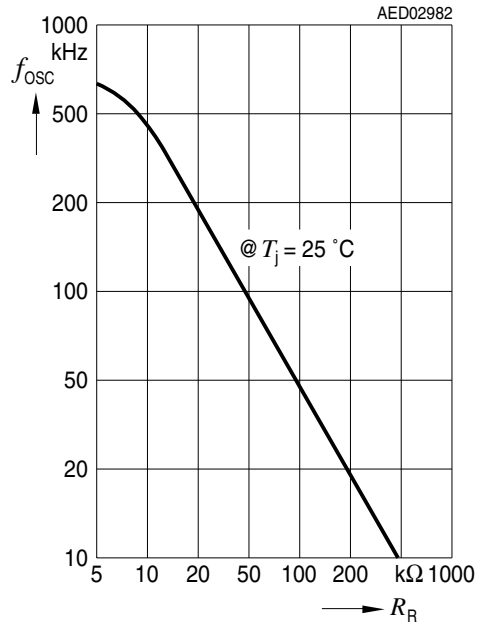

**Efficiency Boost vs. Input Voltage**

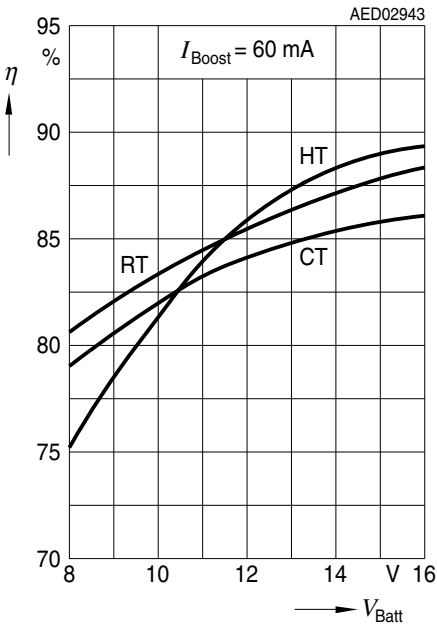

**Boost Output Voltage vs. Load**

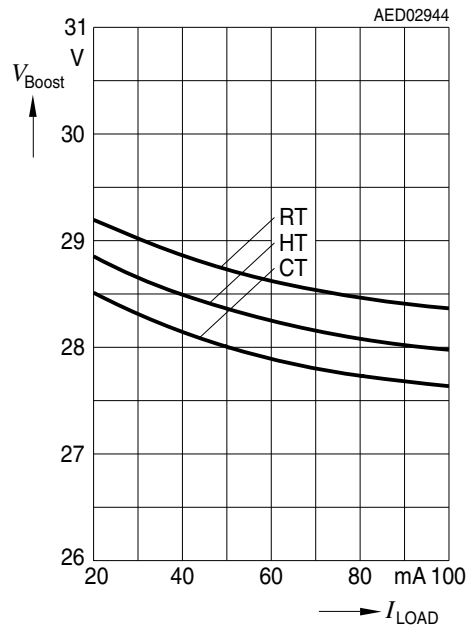

Diagrams: Oscillator and Boost/Buck-Converter Performance

**Boost and Logic Output Voltage vs. Junction Temperature**

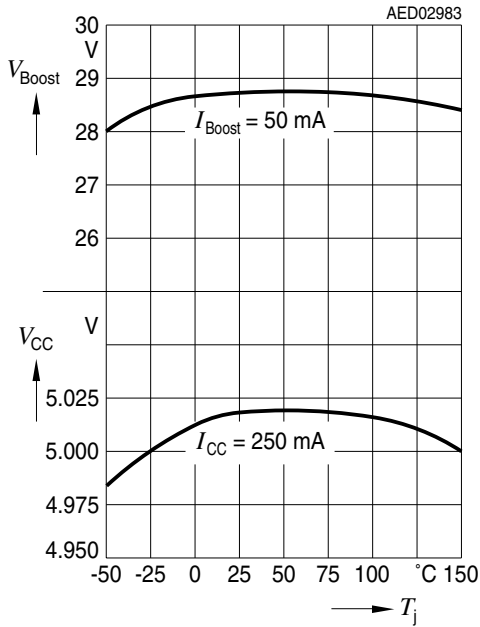

**Boost and Buck Overcurrent Threshold vs. Junction Temperature**

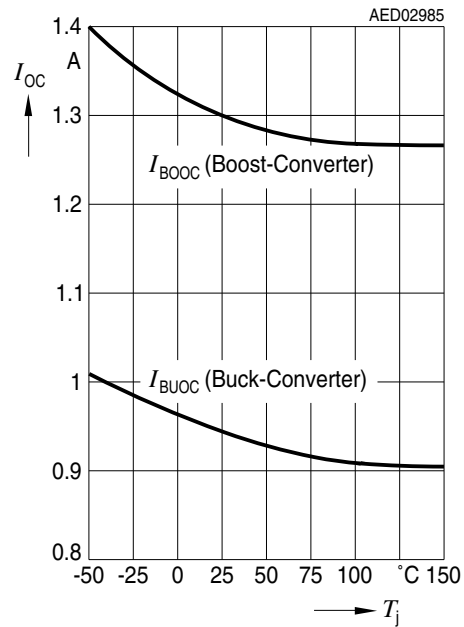

**Boost and Buck ON Resistance vs. Junction Temperature**

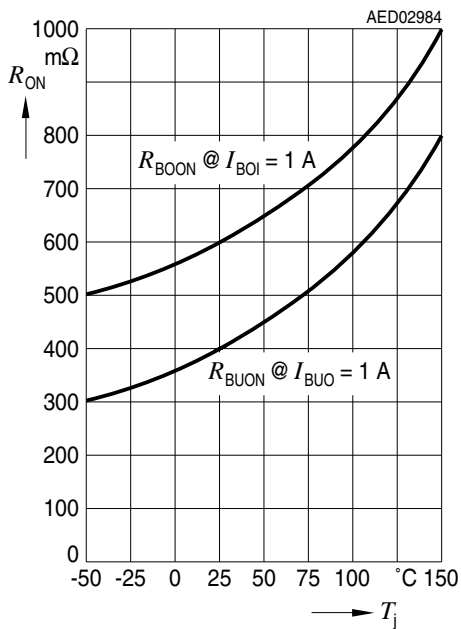

## 7 Package Outlines

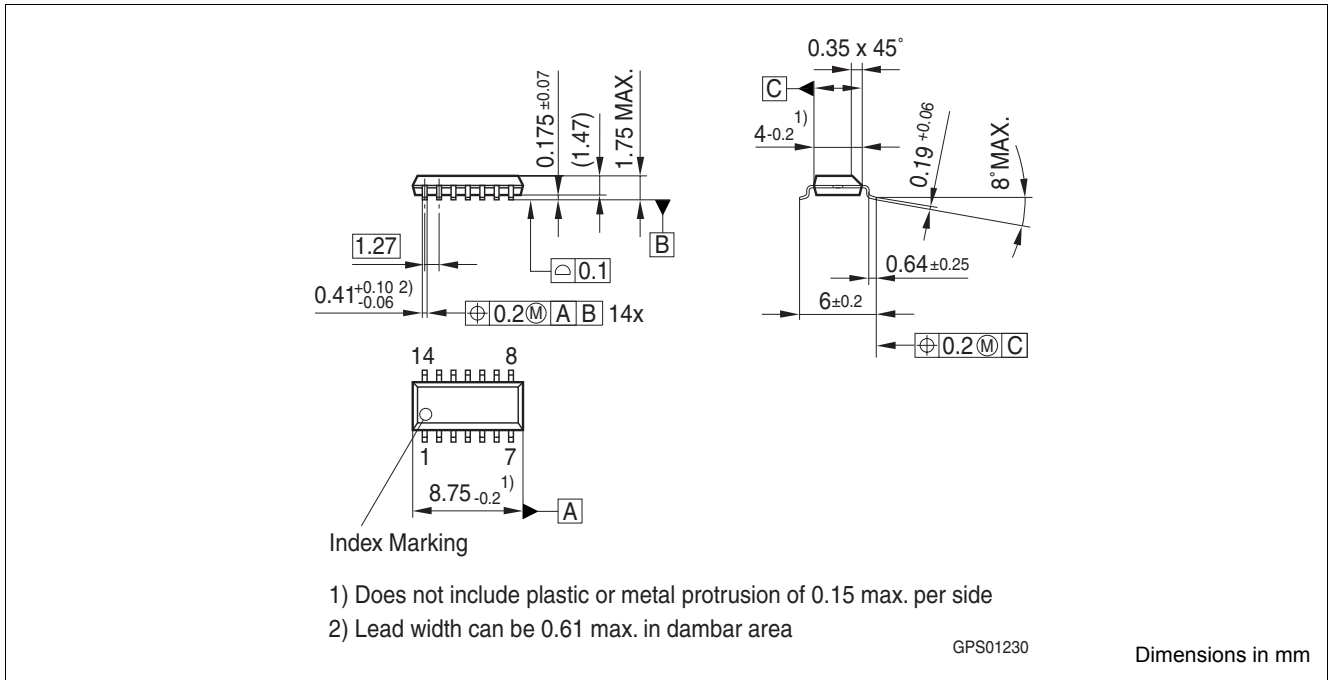

Figure 13 PG-DSO-14-1 (Plastic Dual Small Outline Package)

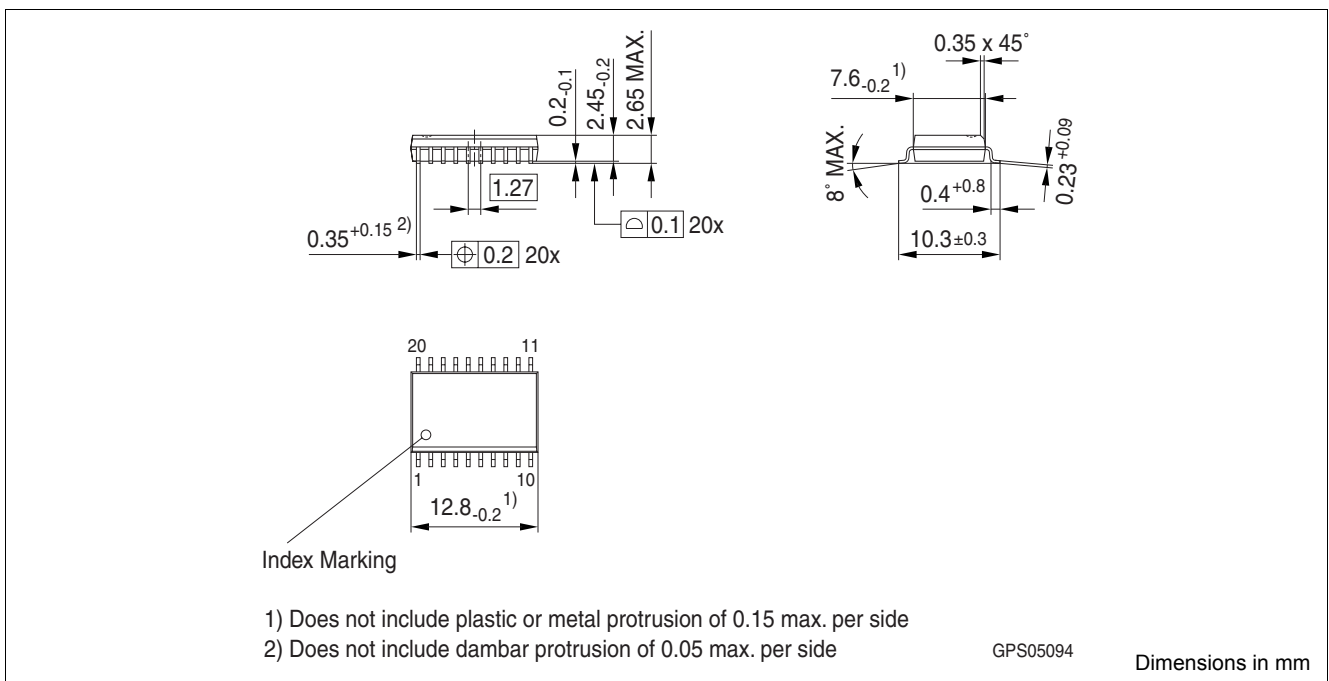

Figure 14 PG-DSO-20-36 (Plastic Dual Small Outline Package)

### Green Product (RoHS compliant)

To meet the world-wide customer requirements for environmentally friendly products and to be compliant with government regulations the device is available as a green product. Green products are RoHS-Compliant (i.e Pb-free finish on leads and suitable for Pb-free soldering according to IPC/JEDEC J-STD-020).

## 8 Revision History

Revision	Date	Changes
3.4	2007-08-16	Initial version of RoHS-compliant derivate of TLE 6711. <b>Page 2</b> : AEC certified statement added. <b>Page 2</b> and <b>Page 23</b> : RoHS compliance statement and Green product feature added. <b>Page 2</b> and <b>Page 23</b> : Packages changed to RoHS compliant version. Disclaimer updated.
3.3	2006-03-16	Page 9: Figure 5 corrected, $T_{WD} = 128 t_{CYL}$ . Page 19: Figure 12 corrected, Inductor type EPCOS B82442-H1224.



**Edition 2007-08-16**

**Published by  
Infineon Technologies AG  
81726 Munich, Germany**

**© 2007 Infineon Technologies AG  
All Rights Reserved.**

### **Legal Disclaimer**

The information given in this document shall in no event be regarded as a guarantee of conditions or characteristics. With respect to any examples or hints given herein, any typical values stated herein and/or any information regarding the application of the device, Infineon Technologies hereby disclaims any and all warranties and liabilities of any kind, including without limitation, warranties of non-infringement of intellectual property rights of any third party.

### **Information**

For further information on technology, delivery terms and conditions and prices, please contact the nearest Infineon Technologies Office ([www.infineon.com](http://www.infineon.com)).

### **Warnings**

Due to technical requirements, components may contain dangerous substances. For information on the types in question, please contact the nearest Infineon Technologies Office.

Infineon Technologies components may be used in life-support devices or systems only with the express written approval of Infineon Technologies, if a failure of such components can reasonably be expected to cause the failure of that life-support device or system or to affect the safety or effectiveness of that device or system. Life support devices or systems are intended to be implanted in the human body or to support and/or maintain and sustain and/or protect human life. If they fail, it is reasonable to assume that the health of the user or other persons may be endangered.