

# Boost to battery evaluation kit

TLD5099EP

## About this document

### Product description

The TLD5099EP is an AEC qualified DC/DC boost controller, especially designed to drive LEDs.

- Built in diagnosis and protection features
- Pulse width modulator to implement a dimming function with reduced color shifting
- Spread spectrum modulator to improve the EMI performance

### Scope and purpose

Scope of this user manual is to provide to the audience instructions on usage of TLD5099EP boost to battery evaluation board.

### Intended audience

This document is intended for engineers who need to perform measurements and check performances with TLD5099EP boost to battery evaluation board.

## Table of contents

	<b>About this document</b> .....	1
	<b>Table of contents</b> .....	1
<b>1</b>	<b>Description</b> .....	2
<b>2</b>	<b>Quick start procedure</b> .....	4
<b>3</b>	<b>Current adjustment</b> .....	5
<b>4</b>	<b>Power derating (Battery dependent current)</b> .....	6
<b>5</b>	<b>Embedded PWM engine</b> .....	7
<b>6</b>	<b>Cold crank survival circuit</b> .....	8
<b>7</b>	<b>Schematics</b> .....	9
<b>8</b>	<b>PCB layout</b> .....	12
<b>9</b>	<b>Bill of material</b> .....	13
<b>10</b>	<b>Efficiency measurements</b> .....	15
<b>11</b>	<b>Maximizing efficiency</b> .....	16
<b>12</b>	<b>Minimizing EMI emissions</b> .....	17
<b>13</b>	<b>Revision history</b> .....	18
	<b>Disclaimer</b> .....	19

## 1 Description

### 1 Description

Evaluation board for high power LED application with TLD5099EP product in boost to battery topology.

Default configuration of the board is boost to battery topology without any additional features enabled. In this configuration, it can deliver up to 21 W to the load with an efficiency above 84%. Auxiliary circuits to protect the DC/DC and the load during short to ground are present.

The board is also equipped with the following features, enabled by jumpers:

- Output current adjustment trimmer
- Power derating circuitry
- Embedded PWM engine
- Cold Crank Survival Circuit (**CCSC**)

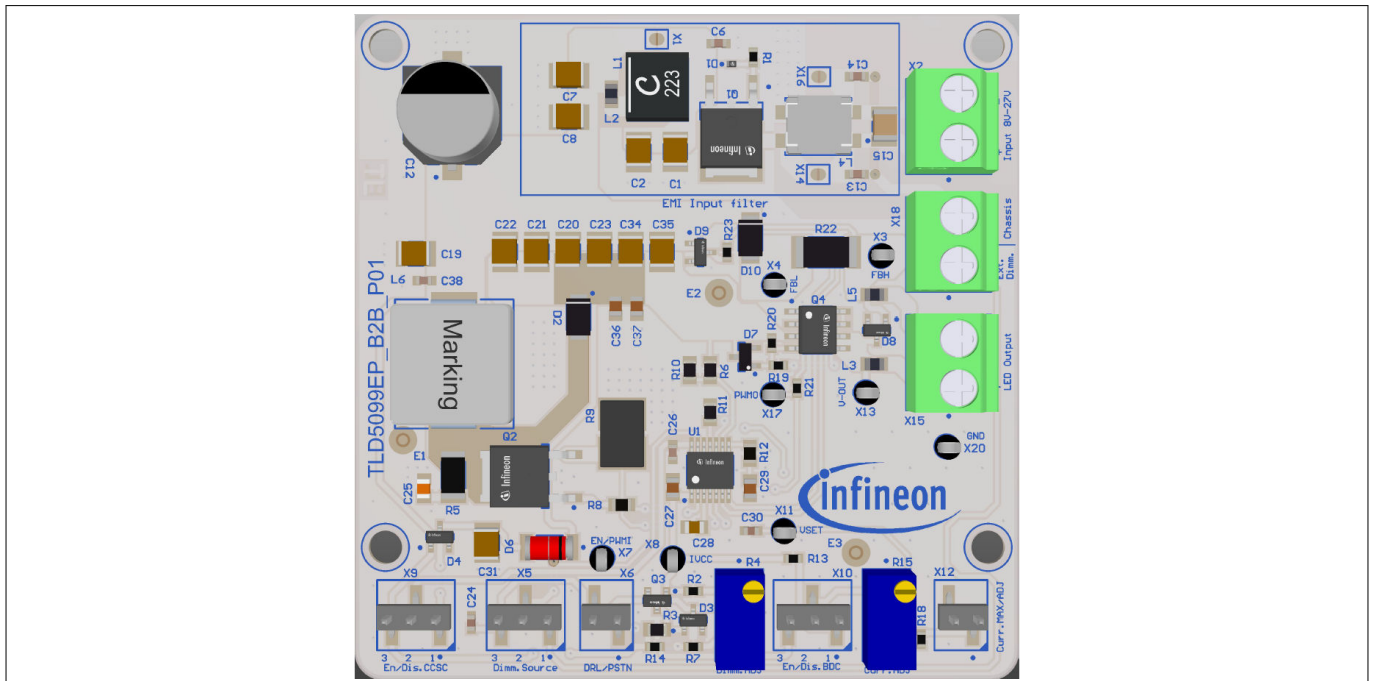
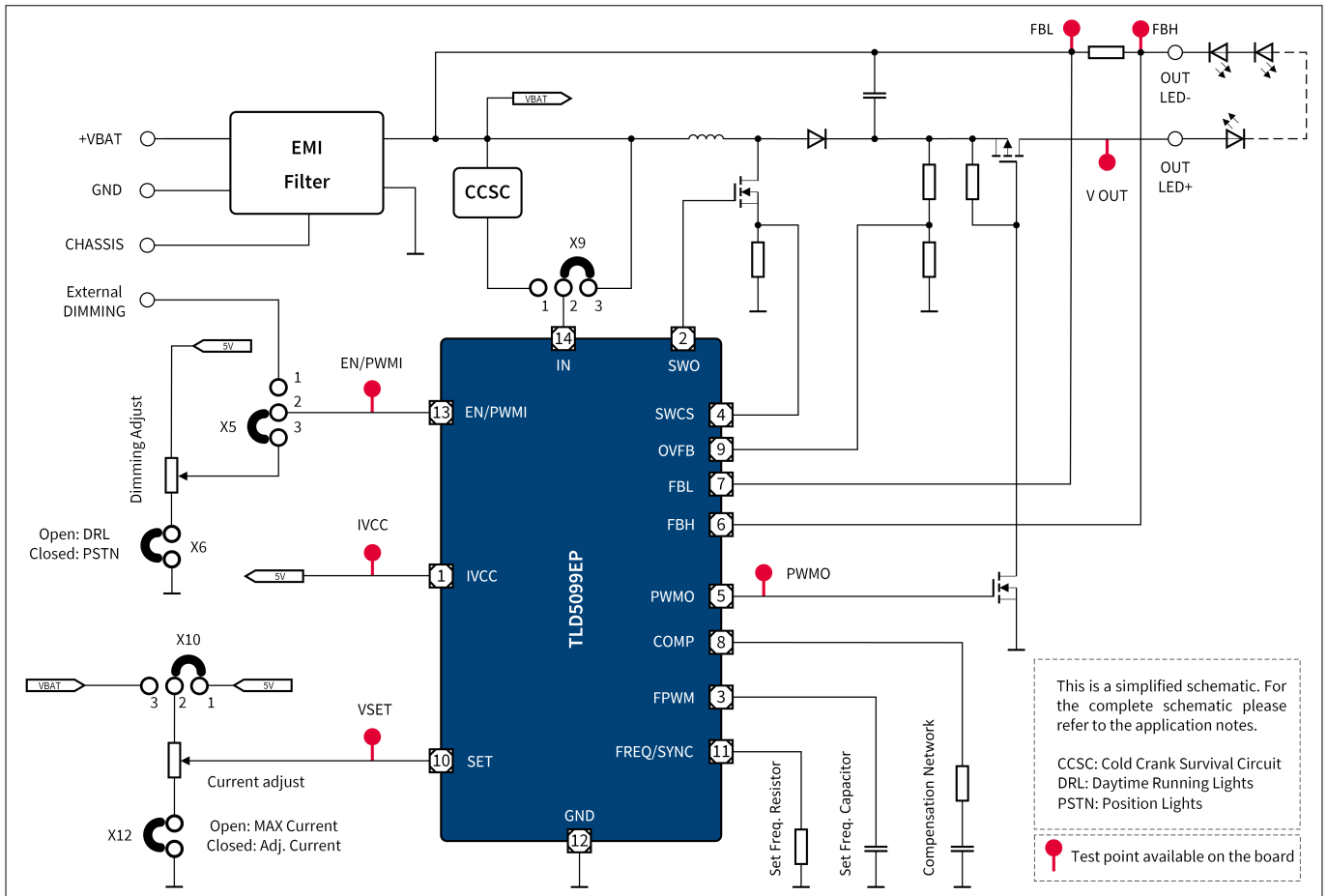

Figure 1 Board picture

**1 Description**



**Figure 2** Simplified schematic

**Table 1** Performance summary

Parameter	Conditions	Value
Input supply voltage	Jumper X9 in position 2-3 (CCSC deactivated) Parameter degradation below 6.5 V	8 V to 27 V Down to 6.5 V for less than 2 s
Input supply voltage	Jumper X9 in position 1-2 (CCSC active)	8 V to 27 V Down to 3.0 V for less than 2 s
Output current	Jumper X12 open	1 A
Switching frequency	$V_{IN} = 13.2 \text{ V}$ ; spread spectrum "on"	400 kHz
Efficiency	Measured with 7 white standard LED 3 V @ 1 A output current	> 84%
Output voltage range	Output voltage related to positive input	6 V to 23 V
Output overvoltage protection	Output voltage related to ground	59 V

**2 Quick start procedure**

**2 Quick start procedure**

The default configuration of the board has all additional features disabled. Jumpers are populated as follows:

**Table 2 Jumper population**

Jumper number	Conditions	Meaning
X9	Close 2-3	Disable CCSC
X5	Close 2-1	External dimming enabled
X10	Close 2-1	Disable battery dependent current

The default configuration is depicted below:

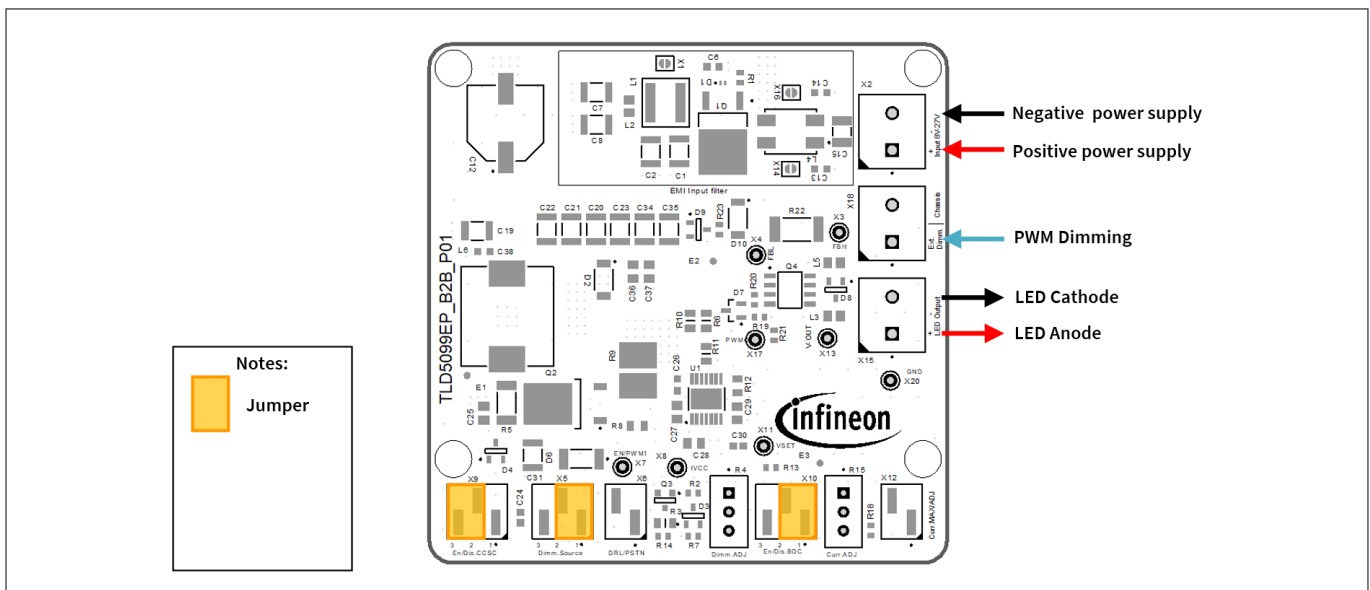

**Figure 3 Default configuration of the board**

In this configuration, PWM signal has to be applied as digital signal on X18 (max 45 V), and the output current cannot be adjusted.

**3 Current adjustment**

**3 Current adjustment**

Output current adjustment can be performed by changing the value of trimmer R15 with a screwdriver, when X10 is closed in position 1-2 and X12 is closed. Output current can vary from 0 to 100% of the maximum output current (in this demoboard from 0 to 1 A). By removing the X12 jumper, output current will reach its maximum value.

Jumpers are populated as follows:

**Table 3 Jumper population**

Jumper number	Condition	Meaning
X9	Close 2-3	Disable CCSC
X5	Close 2-1	External dimming enabled
X10	Close 2-1	Disable battery dependent current
X12	Closed	Adjustable output current enabled

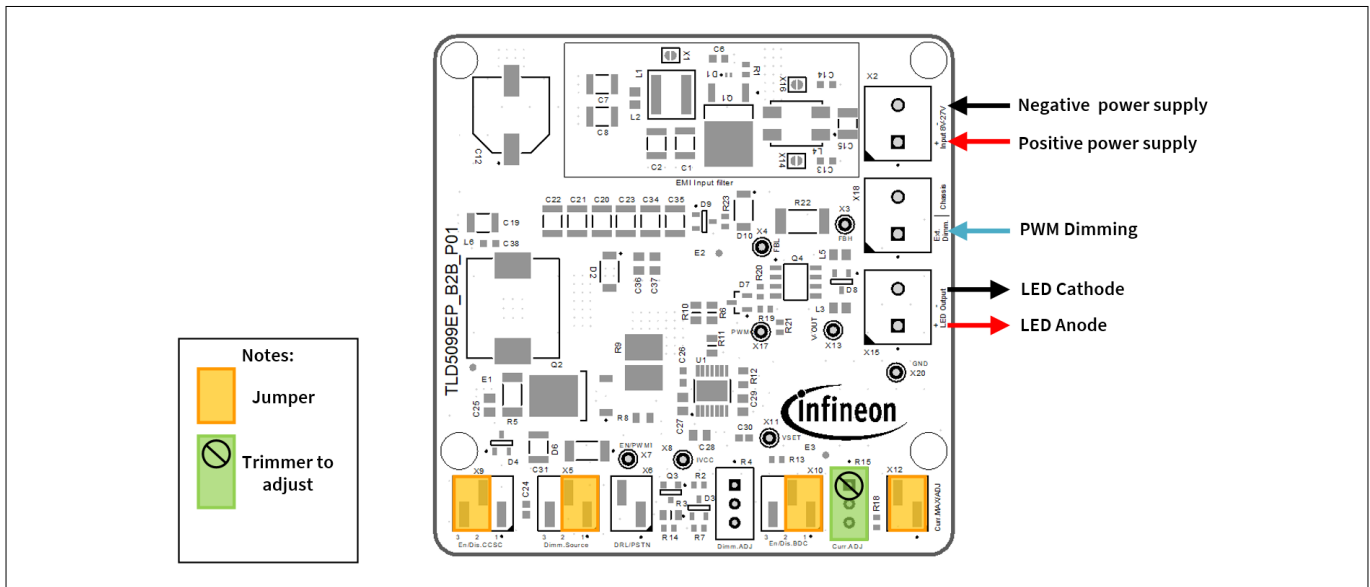

**Figure 4 Current adjustment**

**4 Power derating (Battery dependent current)**

**4 Power derating (Battery dependent current)**

Power derating acts by reducing  $V_{SET}$  (and thus the output current) when the battery voltage drops below 8 V. It works better when R15 is trimmed to its maximum value, otherwise a different derating profile is applied. If a different derating profile is needed, R14 has to be changed accordingly, in order to have 1.6 V on pin SET when the battery voltage reach the desired threshold below which the output current must decrease proportionally. A quick formula to calculate R14 is:

$$R14 = (R15 + R18) \cdot \left( \frac{V_{BATT}}{1.6} - 1 \right)$$

where  $R15 = 10\text{ k}\Omega$  and  $R18 = 560\ \Omega$ .

For example, if the power derating should start when the battery voltage drops under 12 V, R14 must be replaced with a 68 k $\Omega$  0603 resistor (please refer to the TLD5099EP datasheets for more information).

Jumpers are populated as follows:

**Table 4 Jumper population**

Jumper number	Condition
X9	Close 2-3
X5	Close 2-1
X10	Close 2-3
X12	Closed

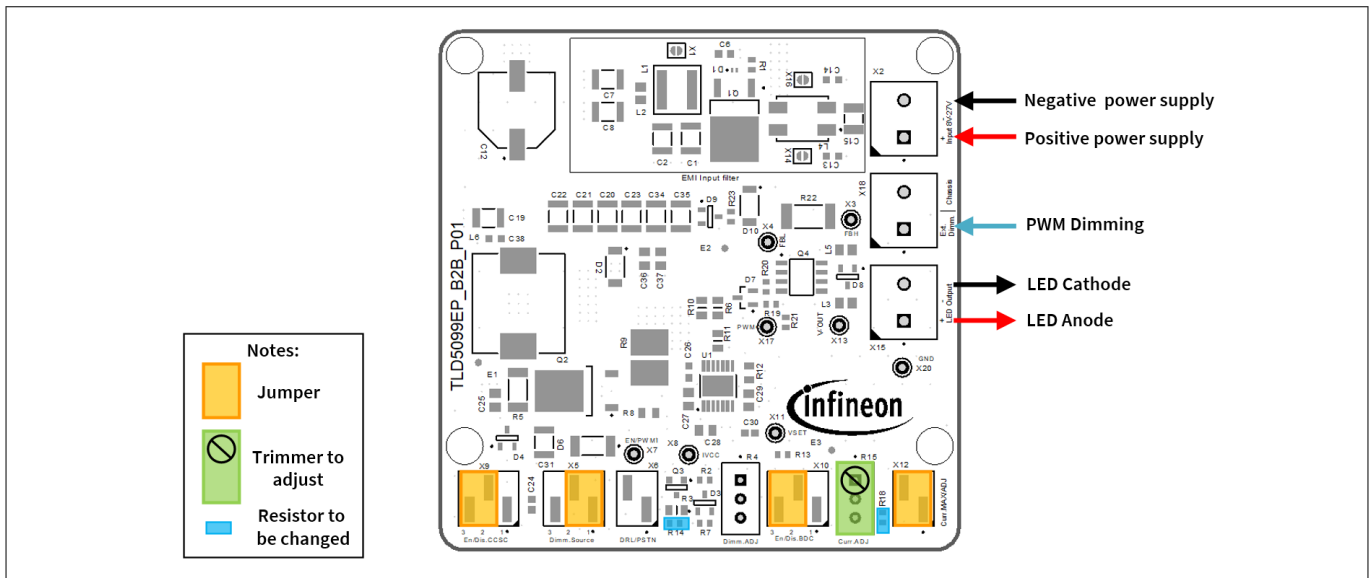

**Figure 5 Power derating**

**5 Embedded PWM engine**

**5 Embedded PWM engine**

Embedded PWM engine provides an internal PWM signal without any external dimming signal required. It is enabled when X5 is closed in position 2-3. If X6 is open, EN/PWMI/PWMA pin is biased at 5 V and then the duty cycle is 100%; closing X6, the duty cycle is adjustable by means of trimmer R4. The PWM frequency is set to 350 Hz; if another PWM frequency is needed, C28 must be changed to a proper value (please refer to the TLD5099EP datasheets for more information).

Jumpers are populated as follows:

**Table 5 Jumper population**

Jumper number	Condition	Meaning
X9	Close 2-3	Disable CCSC
X5	Close 2-3	Internal dimming enabled
X10	Close 2-1	Disable battery dependent current
X6	Closed	Adjustable PWM dimming for position light

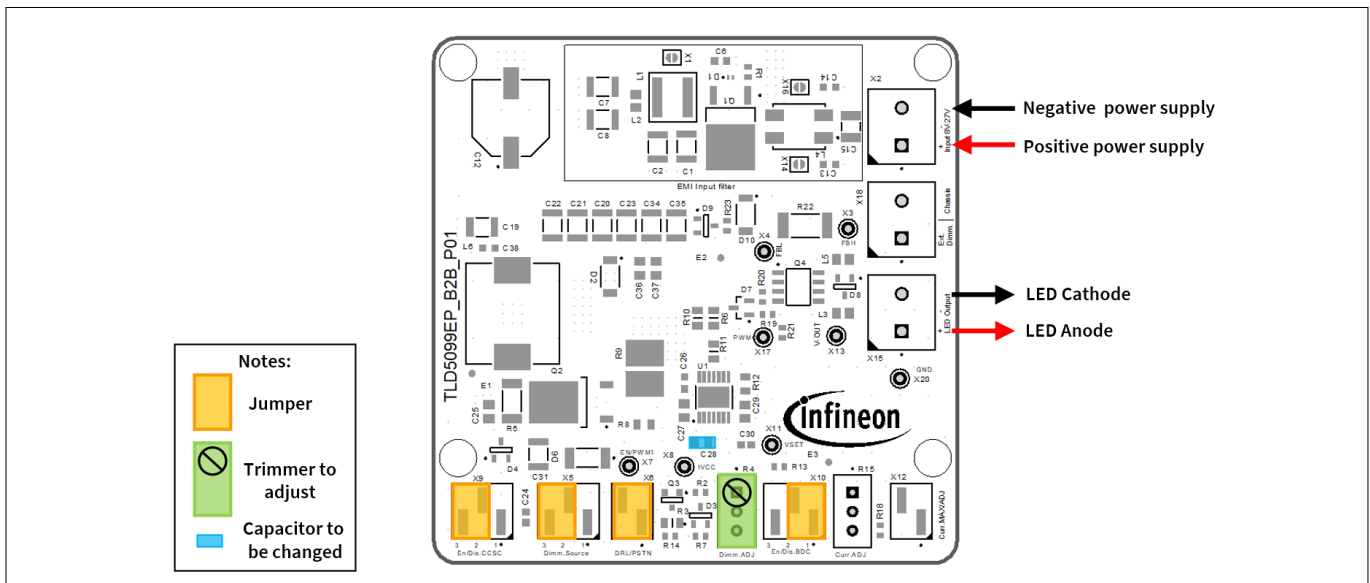

**Figure 6 Embedded PWM engine**

**6 Cold crank survival circuit**

**6 Cold crank survival circuit**

This feature helps the system to survive the LV124 test E11 “severe test pulse”, when input voltage drops below 4.5 V that is the minimum input voltage for the TLD5099EP. This circuit feeds back the device with the output voltage when the input voltage drops. To activate this feature, close X9 in position 1-2. Other settings can be left as preferred.

**Warning:** The CCSC uses a Zener diode to adapt the output voltage to the required voltage for the TLD5099EP, so that it can derate the efficiency performance.

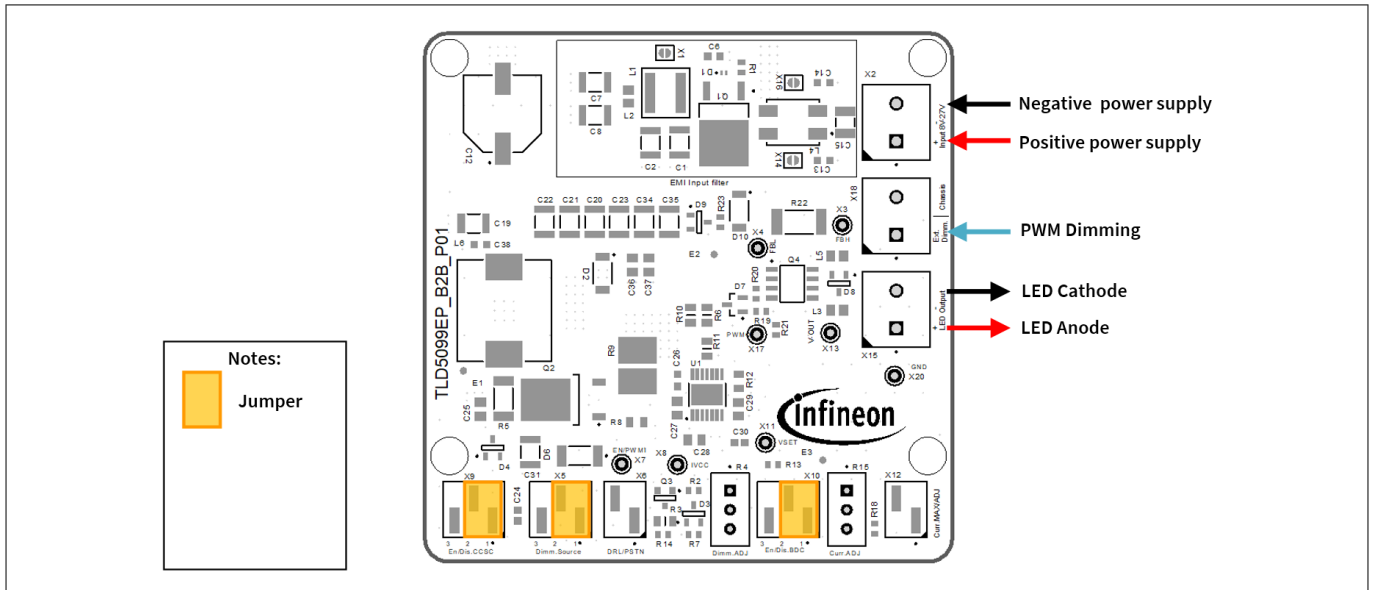

**Figure 7 Cold crank survival circuit**



7 Schematics

7 Schematics

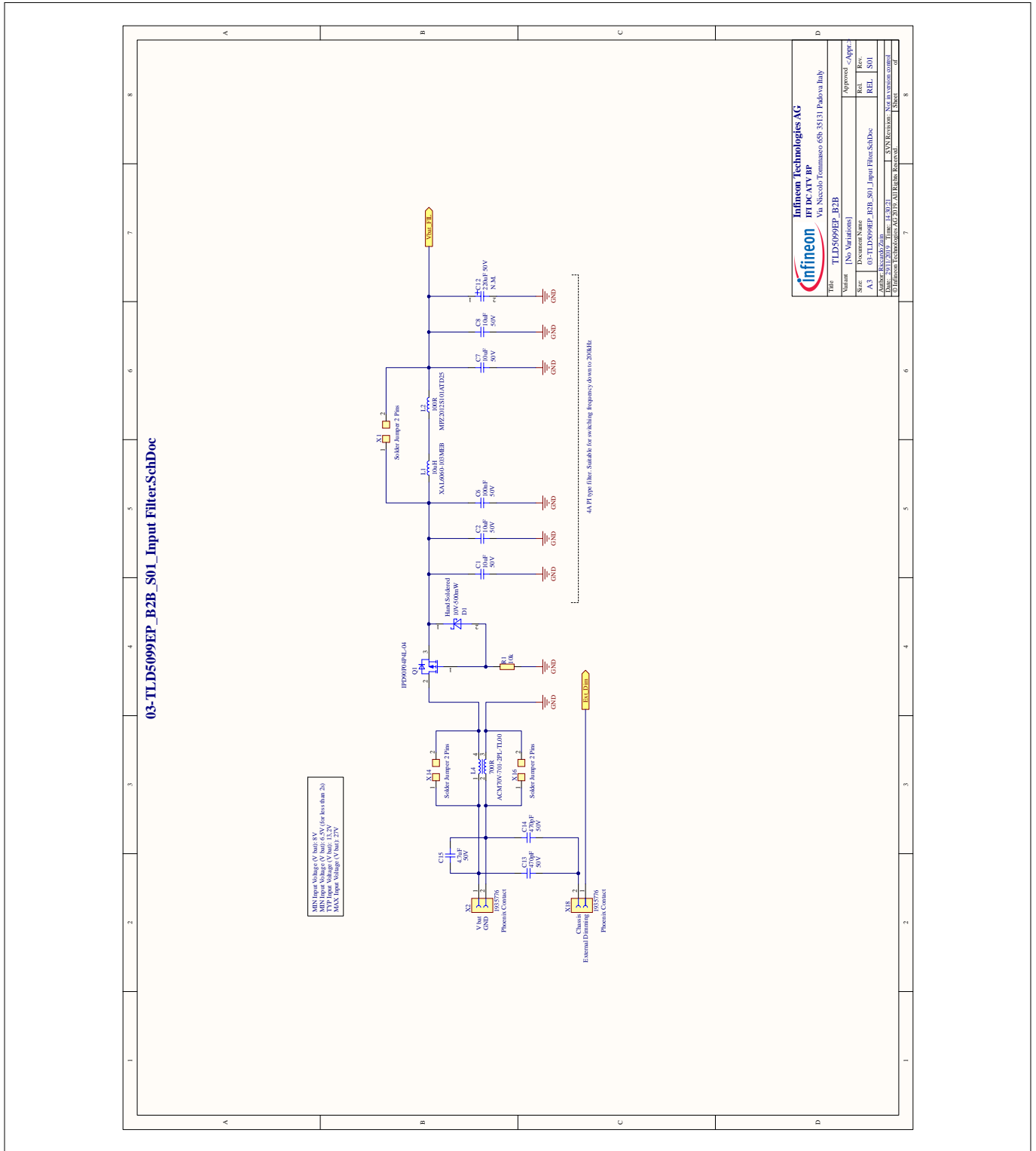

Figure 8 Input filter







**9 Bill of material**

**9 Bill of material**

**Table 6 Bill of material**

<b>Designator</b>	<b>Value</b>	<b>Manufacturer</b>	<b>Manufacturer order number</b>
C1, C2, C7, C8, C19, C20, C21, C22, C23, C31, C34, C35	10uF	muRata	GCM32EC71H106KA03
C6, C26, C38	100nF	AVX	06035C104K4Z2A
C12	220uF	Panasonic	EEEFK1H221P
C13, C14	470pF	muRata	GCM1885C1H471JA16
C15	4.7uF	Kemet	C1210C475K5RACAUTO
C24, C30	1uF	TDK	CGA3E1X7R1V105K080AC
C25	1nF	TDK Corporation	CGA4F2X7R2A102M085AE
C27	10uF	TDK	CGA4J1X7S1C106K125AC
C28	560pF	muRata	GCM2165C2A561JA16
C29, C36	100nF	TDK	CGA4J2X7R2A104M125AE
C37	1uF	TDK Corporation	CGA4J3X7S2A105K125AB
D1	Zener 10V-500mW		
D2, D10	PMEG6030EP,115	Nexperia	PMEG6030EP,115
D3, D4, D8, D9	BAS16	Infineon Technologies	BAS16
D6	10V	Vishay	ZMY10-GS08
D7	10V	ON Semiconductor	BZX84C10LT1G
L1	10uH	Coilcraft	XAL6060-103MEB
L2	100H	TDK Corporation	MPZ2012S101ATD25
L3, L5	1kH	TDK	MPZ2012S102ATD25
L4		TDK	ACM70V-701-2PL-TL00
L6	47uH	Bourns	SRP1265A-470M
Q1	IPD90P04P4L-04	Infineon Technologies	IPD90P04P4L-04
Q2	IPD22N08S2L-50	Infineon	IPD22N08S2L-50
Q3	BSS138N	Infineon Technologies	BSS138N
Q4	BSO615CGHUMA1	Infineon Technologies	BSO615CGHUMA1
R1, R23	10kΩ	Vishay	CRCW060310K0FK
R2	8.2kΩ	Vishay	CRCW06038K20FK
R3	2.2kΩ	Vishay	CRCW08052K20FK
R4, R15	10kΩ	Vishay	T93YA103KT20
R5	2.2Ω	Vishay	CRCW20102R20FK
R6	47kΩ	Vishay	CRCW080547K0FK
R7	3.3kΩ	Vishay	CRCW06033K30FK
R8, R12	0Ω	Yageo	AC0805JR-070RL

**9 Bill of material**

**Table 6 Bill of material (continued)**

<b>Designator</b>	<b>Value</b>	<b>Manufacturer</b>	<b>Manufacturer order number</b>
R9	33mΩ	Vishay	WSHM2818R0330FEA
R10	1kΩ	Vishay	CRCW08051K00FK
R11	2kΩ	Vishay	CRCW08052K00FK
R13, R20	22kΩ	Vishay	CRCW060322K0FK
R14	39kΩ	Vishay	CRCW060339K0FK
R18	560Ω	Vishay	CRCW0603560RFK
R19	27kΩ	Vishay	CRCW060327K0FK
R21	10Ω	Vishay	CRCW060310R0FK
R22	300mΩ	Vishay	WSL2512R3000FEA
U1	TLD5099EP	Infineon Technologies	TLD5099EP
X1, X14, X16	Solder Jumper 2 Pins	Infineon Technologies AG	Solder Jumper 2 Pins
X2, X15, X18	1935776	Phoenix Contact	1935776
X3, X4, X7, X8, X11, X13, X17, X20	5001	Keystone	5001
X5, X9, X10	TSM-103-01-S-SV	Samtec	TSM-103-01-S-SV
X6, X12	TSM-102-01-S-SV	Samtec	TSM-102-01-S-SV

**10 Efficiency measurements**

**10 Efficiency measurements**

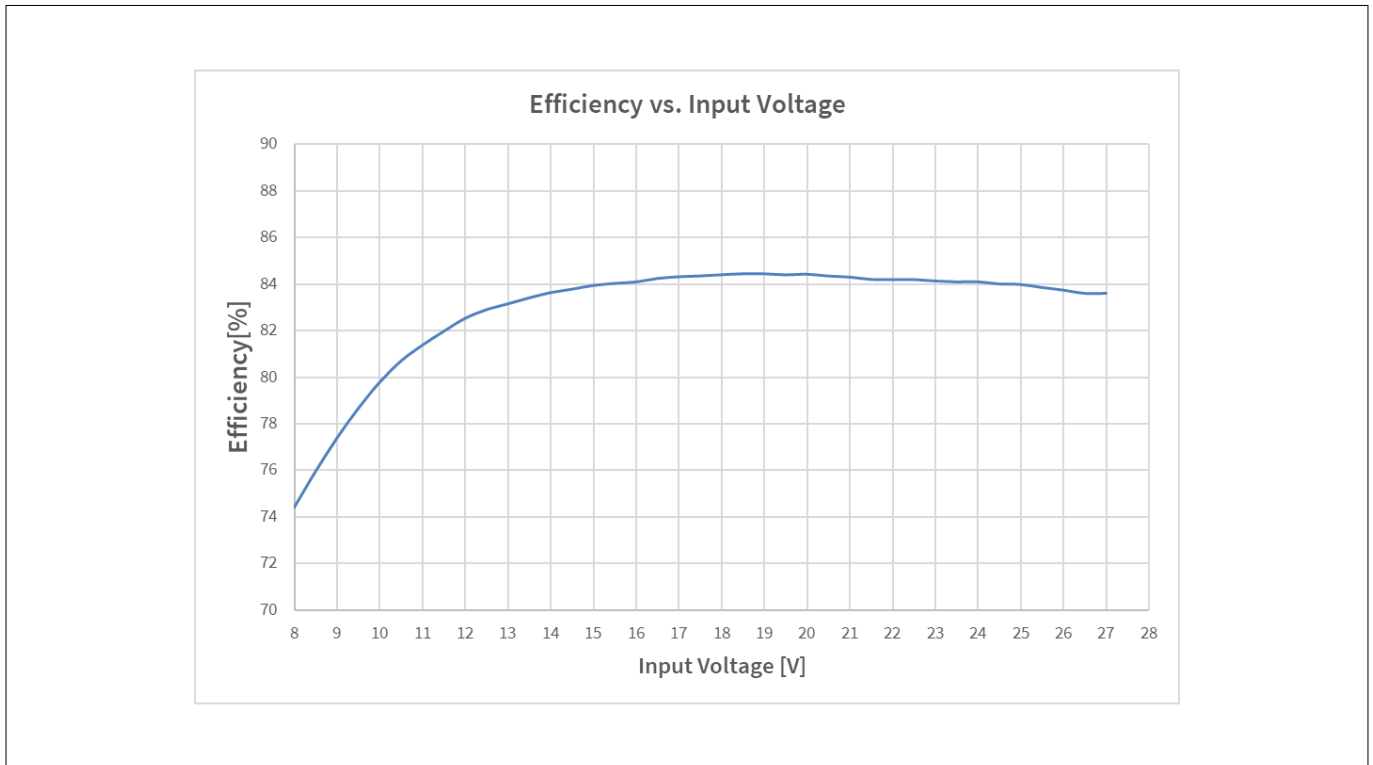

**Figure 13 Efficiency vs. input voltage**

This efficiency performance has been obtained with:

**Table 7 Parameters influencing efficiency**

Output load:	Series of 7 white standard LED with $V_j = 3\text{ V}$ kept cooled with forced air
EMI filter:	Totally bypassed by closing the jumpers X1, X14 and X16
CCSC:	Off (jumper X9 closed on 2-3)
Current adjustment:	Off (jumper X12 left open)
Dimming output:	Off (jumper X6 left open)
Power derating:	Off (jumper X10 closed on 1-2)

Efficiency performances can be increased: refer to [Chapter 11](#).

---

## 11 Maximizing efficiency

### 11 Maximizing efficiency

This evaluation board has been designed to reach a fair compromise between efficiency performance and EMI emissions compliance.

Nevertheless, if the maximum efficiency is needed, the following actions should be considered:

1. Remove the snubber circuit R5, C25 or choose a lower value for the capacitor C25 (for example 470 pF)
2. Bypass the whole EMI filter, by bridging the jumpers X1, X14 and X16
3. Bypass the output ferrite beads L3 and L5
4. Replace the main inductor L6 with one that boasts a lower parasitic DC resistance, for example
  - Vishay IHLP6767GZER470M8A
  - Bourns SRP1770TA-470M
5. Turn off the CCSC by placing the jumper X9 on position 2-3



## **12 Minimizing EMI emissions**

This evaluation board has been designed to reach a fair compromise between efficiency performance and EMI emissions compliance. Furthermore, this evaluation board can fulfill the class V of the CISPR25 in conducted emissions from 150 kHz to 108 MHz.

Nevertheless, if the minimum EMI emission is required, the following actions should be considered:

- 1.** Choose a higher value for the capacitor C25 (for example 2.2 nF)
- 2.** Include the whole EMI filter, by removing bridges from the jumpers X1, X14 and X16.
- 3.** Replace the 0  $\Omega$  resistor R8 with a small value like 10  $\Omega$  or 22  $\Omega$
- 4.** Replace the main inductor L6 with a shielded one (for example the Cynotec VCHE106G-470MS6) and connecting to ground the shield
- 5.** With a short piece of wire connect the CHASSIS TERMINAL to the test ground plane as close as possible to where the board is placed

---

**13 Revision history**

## **13 Revision history**

<b>Document version</b>	<b>Date of release</b>	<b>Description of changes</b>
Rev. 1.00	2020-01-29	First release related to evalboard S01_P01.

## Trademarks

All referenced product or service names and trademarks are the property of their respective owners.

**Edition 2020-01-29**

**Published by**

**Infineon Technologies AG**

**81726 Munich, Germany**

**© 2020 Infineon Technologies AG**

**All Rights Reserved.**

**Do you have a question about any aspect of this document?**

**Email: [erratum@infineon.com](mailto:erratum@infineon.com)**

**Document reference**

**IFX-awj1578581807661**

## IMPORTANT NOTICE

The information contained in this application note is given as a hint for the implementation of the product only and shall in no event be regarded as a description or warranty of a certain functionality, condition or quality of the product. Before implementation of the product, the recipient of this application note must verify any function and other technical information given herein in the real application. Infineon Technologies hereby disclaims any and all warranties and liabilities of any kind (including without limitation warranties of non-infringement of intellectual property rights of any third party) with respect to any and all information given in this application note.

The data contained in this document is exclusively intended for technically trained staff. It is the responsibility of customer's technical departments to evaluate the suitability of the product for the intended application and the completeness of the product information given in this document with respect to such application.

## WARNINGS

Due to technical requirements products may contain dangerous substances. For information on the types in question please contact your nearest Infineon Technologies office.

Except as otherwise explicitly approved by Infineon Technologies in a written document signed by authorized representatives of Infineon Technologies, Infineon Technologies' products may not be used in any applications where a failure of the product or any consequences of the use thereof can reasonably be expected to result in personal injury