

# 12-Channel, 16-Bit, Enhanced Spectrum, PWM, RGB, LED Driver with 3.3-V Linear Regulator

Check for Samples: [TLC5971](#)

## FEATURES

- 12 Constant-Current Sink Output Channels
- Current Capability: 60 mA per channel
- Grayscale (GS) Control with Enhanced Spectrum PWM:
  - 16-bit (65536 steps)
- Global Brightness Control (BC):
  - 7-bit (128 steps)
- Power-Supply Voltage Range:
  - Internal linear regulator: 6 V to 17 V
  - Direct power supply: 3 V to 5.5 V
- LED Supply Voltage: Up to 17 V
- Constant-Current Accuracy:
  - Channel-to-Channel =  $\pm 1\%$  (typ)
  - Device-to-Device =  $\pm 1\%$  (typ)
- Data Transfer Rate: 20 MHz
- Linear Voltage Regulator: 3.3 V
- Auto Display Repeat Function
- Display Timing Reset Function
- Internal/External Selectable GS Clock
- Thermal Shutdown (TSD) with Auto Restart
- Unlimited Device Cascading
- Operating Temperature Range:  $-40^{\circ}\text{C}$  to  $+85^{\circ}\text{C}$

## APPLICATIONS

- RGB LED Cluster Lamp Displays

## DESCRIPTION

The TLC5971 is a 12-channel, constant-current sink driver. Each output channel has individually adjustable currents with 65536 PWM grayscale (GS) steps. Also, each color group can be controlled by 128 constant-current sink steps with the global brightness control (BC) function. GS control and BC are accessible via a two-wire signal interface. The maximum current value for each channel is set by a single external resistor. All constant-current outputs are turned off when the IC is in an over-temperature condition.

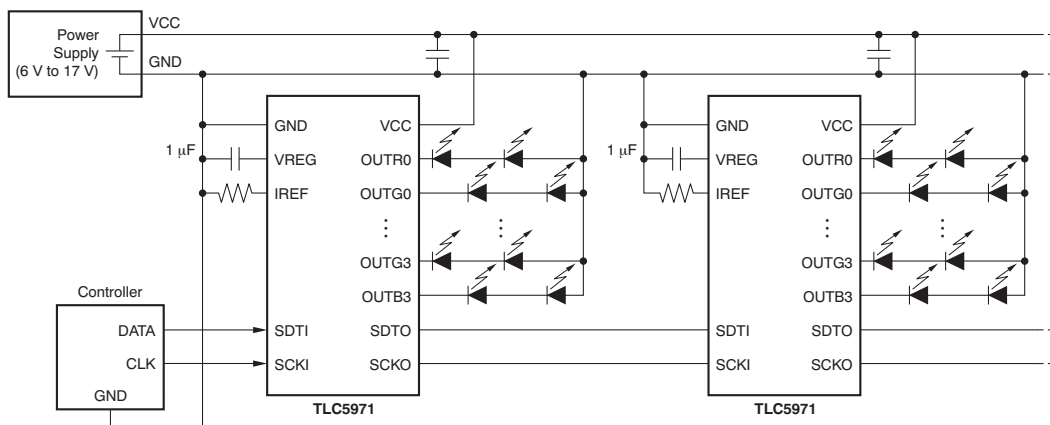

NOTE: The number of LEDs in series changes, depending on the VCC voltage.

### Typical Application Circuit Example (Internal Linear Regulator Using VCC = 6 V to 17 V)



Please be aware that an important notice concerning availability, standard warranty, and use in critical applications of Texas Instruments semiconductor products and disclaimers thereto appears at the end of this data sheet.

PowerPAD is a trademark of Texas Instruments Incorporated.

All other trademarks are the property of their respective owners.

**DESCRIPTION (CONTINUED)**

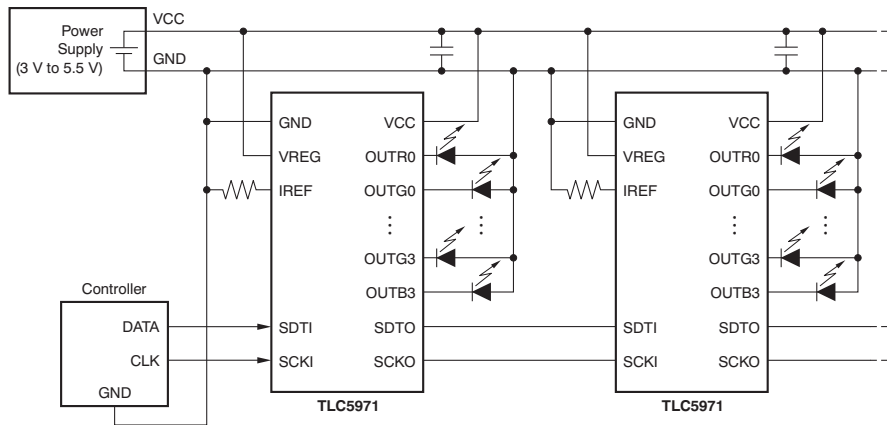

**Typical Application Circuit Example (Direct Power Supplying VCC = 3 V to 5.5 V)**



This integrated circuit can be damaged by ESD. Texas Instruments recommends that all integrated circuits be handled with appropriate precautions. Failure to observe proper handling and installation procedures can cause damage.

ESD damage can range from subtle performance degradation to complete device failure. Precision integrated circuits may be more susceptible to damage because very small parametric changes could cause the device not to meet its published specifications.

**ORDERING INFORMATION<sup>(1)</sup>**

PRODUCT	PACKAGE-LEAD	ORDERING NUMBER	TRANSPORT MEDIA, QUANTITY
TLC5971	HTSSOP-20 PowerPAD™	TLC5971PWPR	Tape and Reel, 2000
		TLC5971PWP	Tube, 70
TLC5971	QFN-24 4.0 mm x 4.0 mm	TLC5971RGER	Tape and Reel, 3000
		TLC5971RGET	Tape and Reel, 250

(1) For the most current package and ordering information, see the Package Option Addendum at the end of this document, or visit the device product folder at [www.ti.com](http://www.ti.com).

## ABSOLUTE MAXIMUM RATINGS<sup>(1)(2)</sup>

Over operating free-air temperature range, unless otherwise noted.

		VALUE		UNIT
		MIN	MAX	
Supply voltage	VCC	-0.3	+18	V
Input voltage	IREF	-0.3	VREG + 0.3	V
	SDTI, SCKI	-0.3	VREG + 0.6	V
Output voltage	OUTR0 to OUTR3, OUTG0 to OUTG3, OUTB0 to OUTB3	-0.3	+18	V
	SDTO, SCKO	-0.3	VREG + 0.3	V
	VREG	-0.3	+6	V
Output current (DC)	OUTR0 to OUTR3, OUTG0 to OUTG3, OUTB0 to OUTB3		75	mA
	VREG		-30	mA
Operating junction temperature	T <sub>J (max)</sub>		+150	°C
Storage temperature	T <sub>stg</sub>	-55	+150	°C
Electrostatic discharge rating	Human body model (HBM)		4	kV
	Charged device model (CDM)		2	kV

- (1) Stresses beyond those listed under *absolute maximum ratings* may cause permanent damage to the device. These are stress ratings only, and functional operation of the device at these or any other conditions beyond those indicated under *recommended operating conditions* is not implied. Exposure to absolute-maximum-rated conditions for extended periods may affect device reliability.
- (2) All voltage values are with respect to network ground terminal.

## THERMAL INFORMATION

THERMAL METRIC <sup>(1)</sup>		TLC5971	TLC5971	UNITS
		PWP	RGE	
		20 PINS	24 PINS	
$\theta_{JA}$	Junction-to-ambient thermal resistance	68.6	38	°C/W
$\theta_{Jctop}$	Junction-to-case (top) thermal resistance	44.2	40.5	
$\theta_{JB}$	Junction-to-board thermal resistance	19.3	10.2	
$\psi_{JT}$	Junction-to-top characterization parameter	2.7	0.3	
$\psi_{JB}$	Junction-to-board characterization parameter	15.7	10	
$\theta_{Jcbot}$	Junction-to-case (bottom) thermal resistance	1.8	2.9	

- (1) For more information about traditional and new thermal metrics, see the *IC Package Thermal Metrics* application report, [SPRA953](#).

## DISSIPATION RATINGS

PACKAGE	DERATING FACTOR ABOVE T <sub>A</sub> = +25°C	POWER RATING T <sub>A</sub> < +25°C	POWER RATING T <sub>A</sub> = +70°C	POWER RATING T <sub>A</sub> = +85°C
HTSSOP 20-pin with PowerPAD soldered <sup>(1)</sup>	25.7 mW/°C	3121 mW	1998 mW	1623 mW
QFN 24-pin exposed thermal pad soldered <sup>(2)</sup>	24.8 mW/°C	3106 mW	1988 mW	1615 mW

- (1) With PowerPAD soldered onto copper area on TI recommended printed circuit board (PCB); 2-oz. copper. For more information, see [application report SLMA002, PowerPAD Thermally-Enhanced Package](#) (available for download at [www.ti.com](http://www.ti.com)).
- (2) The package thermal impedance is calculated in accordance with JESD51-5.

## RECOMMENDED OPERATING CONDITIONS

At  $T_A = -40^\circ\text{C}$  to  $+85^\circ\text{C}$ , and  $V_{CC} = 6\text{ V}$  to  $17\text{ V}$  or  $V_{CC} = V_{REG} = 3\text{ V}$  to  $5.5\text{ V}$ , unless otherwise noted.

		TLC5971			UNIT
		MIN	NOM	MAX	
<b>DC CHARACTERISTICS</b>					
VCC	Supply voltage, internal voltage regulator used	6		17	V
VREG	Supply voltage, VREG connected to VCC	3	3.3	5.5	V
V <sub>O</sub>	Voltage applied to output (OUTR0 to OUTR3, OUTG0 to OUTG3, OUTB0 to OUTB3)			17	V
V <sub>IH</sub>	High-level input voltage (SDTI, SCKI)	0.7 × VREG		VREG	V
V <sub>IL</sub>	Low-level input voltage (SDTI, SCKI)	GND		0.3 × VREG	V
V <sub>IHYS</sub>	Input voltage hysteresis (SDTI, SCKI)		0.2 × VREG		V
I <sub>OH</sub>	High-level output current (SDTO)			-2	mA
I <sub>OL</sub>	Low-level output current (SDTO)			2	mA
I <sub>OLC</sub>	Constant output sink current (OUTR0 to OUTR3, OUTG0 to OUTG3, OUTB0 to OUTB3)			60	mA
I <sub>REG</sub>	Voltage regulator output current (VREG)			-25	mA
T <sub>A</sub>	Operating free temperature range	-40		+85	°C
T <sub>J</sub>	Operating junction temperature	-40		+125	°C
<b>AC CHARACTERISTICS</b>					
f <sub>CLK</sub> (SCKI)	Data clock frequency and GS control clock frequency, SCKI	0.007		20	MHz
t <sub>WH</sub> /t <sub>WL</sub>	Pulse duration, SCKI	10			ns
t <sub>SU</sub>	Setup time, SDTI – SCKI↑	5			ns
t <sub>H</sub>	Hold time, SDTI – SCKI↑	3			ns

## ELECTRICAL CHARACTERISTICS

At  $T_A = -40^\circ\text{C}$  to  $+85^\circ\text{C}$ ,  $V_{CC} = 6\text{ V}$  to  $17\text{ V}$  or  $V_{CC} = V_{REG} = 3\text{ V}$  to  $5.5\text{ V}$ ,  $V_{LED} = 5\text{ V}$ , and  $C_{VREG} = 1\text{ }\mu\text{F}$ , unless otherwise noted. Typical values are at  $T_A = +25^\circ\text{C}$  and  $V_{CC} = 12\text{ V}$ .

PARAMETER		TEST CONDITIONS	TLC5971			UNIT
			MIN	TYP	MAX	
V <sub>OH</sub>	High-level output voltage, SDTO/SCKO	I <sub>OH</sub> = -2 mA	VREG - 0.4		VREG	V
V <sub>OL</sub>	Low-level output voltage, SDTO/SCKO	I <sub>OL</sub> = 2 mA	0		0.4	V
I <sub>I</sub>	Input current, SDTI/SCKI	V <sub>I</sub> = VREG or GND	-1		1	μA
I <sub>CC</sub>	Supply current	SDTI/SCKI = low, BLANK = 1, GS <sub>n</sub> = FFFFh, BCX = 7Fh, V <sub>OUTXn</sub> = 1 V, R <sub>IREF</sub> = 24 kΩ (I <sub>OLCMax</sub> = 2 mA)		2	4	mA
I <sub>CC1</sub>		SDTI/SCKI = low, BLANK = 1, GS <sub>n</sub> = FFFFh, BCX = 7Fh, V <sub>OUTXn</sub> = 1 V, R <sub>IREF</sub> = 1.6 kΩ (I <sub>OLCMax</sub> = 30 mA)		6	9	mA
I <sub>CC2</sub>		SDTI = 10 MHz, SCKI = 20 MHz, BLANK = 0, auto repeat enable, external GS clock selected, GS <sub>n</sub> = FFFFh, BCX = 7Fh, V <sub>OUTXn</sub> = 1 V, R <sub>IREF</sub> = 1.6 kΩ (I <sub>OLCMax</sub> = 30 mA)		14	22	mA
I <sub>CC3</sub>		SDTI = 10 MHz, SCKI = 20 MHz, BLANK = 0, auto repeat enable, external GS clock selected, GS <sub>n</sub> = FFFFh, BCX = 7Fh, V <sub>OUTXn</sub> = 1 V, R <sub>IREF</sub> = 0.82 kΩ (I <sub>OLCMax</sub> = 60 mA)		21	36	mA
I <sub>OLC</sub>	Constant output current, OUTX <sub>n</sub>	All OUTX <sub>n</sub> on, BCX = 7Fh, V <sub>OUTXn</sub> = 1 V, V <sub>OUTIX</sub> = 1 V, R <sub>IREF</sub> = 0.82 kΩ (I <sub>OLCMax</sub> = 60 mA)	56.3	60.5	64.7	mA
I <sub>OLKG</sub>	Leakage output current, OUTX <sub>n</sub>	All OUTX <sub>n</sub> on, BCX = 7Fh, V <sub>OUTXn</sub> = 17 V, V <sub>OUTIX</sub> = 17 V, R <sub>IREF</sub> = 0.82 kΩ (I <sub>OLCMax</sub> = 60 mA)			0.1	μA
ΔI <sub>OLC</sub>	Constant-current error <sup>(1)</sup> (channel-to-channel in same color group), OUTX <sub>n</sub>	All OUTX <sub>n</sub> on, BCX = 7Fh, V <sub>OUTXn</sub> = V <sub>OUTIX</sub> = 1 V, R <sub>IREF</sub> = 0.82 kΩ (I <sub>OLCMax</sub> = 60 mA)		±1	±3	%

- (1) The deviation of each output in the same color group (OUTR0-OUTR3 or OUTG0-OUTG3 or OUTB0-OUTB3) from the average current from the same color group. Deviation is calculated by the formula:

$$\Delta (\%) = \left[ \frac{I_{OLCXn}}{(I_{OLCX0} + I_{OLCX1} + I_{OLCX2} + I_{OLCX3})} - 1 \right] \times 100$$

Where: X = R/G/B, and n = 0-3

**ELECTRICAL CHARACTERISTICS (continued)**

At  $T_A = -40^\circ\text{C}$  to  $+85^\circ\text{C}$ ,  $V_{CC} = 6\text{ V}$  to  $17\text{ V}$  or  $V_{CC} = V_{REG} = 3\text{ V}$  to  $5.5\text{ V}$ ,  $V_{LED} = 5\text{ V}$ , and  $C_{VREG} = 1\text{ }\mu\text{F}$ , unless otherwise noted. Typical values are at  $T_A = +25^\circ\text{C}$  and  $V_{CC} = 12\text{ V}$ .

PARAMETER	TEST CONDITIONS	TLC5971			UNIT
		MIN	TYP	MAX	
$\Delta I_{OLC1}$	Constant current error <sup>(2)</sup> (device-to-device in same color group), OUTXn		$\pm 1$	$\pm 4$	%
$\Delta I_{OLC2}$	Line regulation of constant-current output, OUTXn <sup>(3)</sup>		$\pm 0.5$	$\pm 1$	%/V
$\Delta I_{OLC3}$	Load regulation of constant-current output, OUTXn <sup>(4)</sup>		$\pm 1$	$\pm 3$	%/V
$T_{SD}$	Thermal shutdown temperature	150	165	180	$^\circ\text{C}$
$T_{HYS}$	Thermal shutdown hysteresis	5	10	20	$^\circ\text{C}$
$V_{REF}$	Reference voltage output, IREF	1.18	1.21	1.24	V
$V_{REG}$	Linear regulator output voltage, VREG	3.1	3.3	3.5	V
$\Delta V_{REG}$	Line regulation of linear regulator, VREG			90	mV
$\Delta V_{REG1}$	Load regulation of linear regulator, VREG			120	mV
$V_{STR}$	Undervoltage lockout release, VREG	2.5	2.7	2.9	V
$V_{HYS}$	Undervoltage lockout hysteresis, VREG	300	400	500	mV

- (2) The deviation of each color group constant-current average from the ideal constant-current value. Deviation is calculated by the following formula:

$$\Delta (\%) = \left[ \frac{(I_{OLCX0} + I_{OLCX1} + I_{OLCX2} + I_{OLCX3})}{4} - (\text{Ideal Output Current}) \right] \times 100$$

Where:  $X = R/G/B$ .

Ideal current is calculated by the following formula for the OUTRn and OUTGn groups:

$$I_{OLCXn(\text{IDEAL})} (\text{mA}) = 41 \times \left( \frac{1.21}{R_{IREF} (\Omega)} \right)$$

Where:  $X = R/G/B$ .

- (3) Line regulation is calculated by this equation:

$$\Delta (\%/V) = \left[ \frac{(I_{OLCXn} \text{ at } V_{CC} = 5.5\text{ V}) - (I_{OLCXn} \text{ at } V_{CC} = 3\text{ V})}{(I_{OLCXn} \text{ at } V_{CC} = 3\text{ V})} \right] \times \frac{100}{5.5\text{ V} - 3\text{ V}}$$

Where:  $X = R/G/B$ ,  $n = 0-3$ .

- (4) Load regulation is calculated by the equation:

$$\Delta (\%/V) = \left[ \frac{(I_{OLCXn} \text{ at } V_{OUTXn} = 3\text{ V}) - (I_{OLCXn} \text{ at } V_{OUTXn} = 1\text{ V})}{(I_{OLCXn} \text{ at } V_{OUTXn} = 1\text{ V})} \right] \times \frac{100}{3\text{ V} - 1\text{ V}}$$

Where:  $X = R/G/B$ ,  $n = 0-3$ .

- (5) Not tested, specified by design.

## SWITCHING CHARACTERISTICS

At  $T_A = -40^\circ\text{C}$  to  $+85^\circ\text{C}$ ,  $V_{CC} = 6\text{ V}$  to  $17\text{ V}$  or  $V_{CC} = V_{REG} = 3\text{ V}$  to  $5.5\text{ V}$ ,  $C_{VREG} = 1\ \mu\text{F}$ ,  $C_L = 15\ \text{pF}$ ,  $R_L = 68\ \Omega$ , and  $V_{LED} = 5\text{ V}$ , unless otherwise noted. Typical values are at  $T_A = +25^\circ\text{C}$  and  $V_{CC} = 12\text{ V}$ .

PARAMETER		TEST CONDITIONS	TLC5971			UNIT
			MIN	TYP	MAX	
$t_{R0}$	Rise time, SDTO/SCKO			3	10	ns
$t_{R1}$	Rise time, OUTXn	BCX = 7Fh		5	15	ns
$t_{F0}$	Fall time, SDTO/SCKO			3	10	ns
$t_{F1}$	Fall time, OUTXn	BCX = 7Fh		15	25	ns
$t_{D0}$	Propagation delay	SCKI $\uparrow$ to SDTO $\downarrow$	10	25	60	ns
$t_{D1}$		SCKI $\uparrow$ to SCKO $\uparrow$	5	15	40	ns
$t_{D2}^{(1)}$		SCKO $\uparrow$ to SDTO $\downarrow$	5	10	20	ns
$t_{D3}$		SCKI $\uparrow$ to OUTRn $\uparrow\downarrow$ , BLANK = 0, BCXn = 7Fh, OUTTMG = 1 Or SCKI $\downarrow$ to OUTRn $\uparrow\downarrow$ , BLANK = 0, BCXn = 7Fh, OUTTMG = 0	10	25	60	ns
$t_{D4}$		SCKI $\uparrow$ to OUTGn $\uparrow\downarrow$ , BLANK = 0, BCXn = 7Fh, OUTTMG = 1 Or SCKI $\downarrow$ to OUTGn $\uparrow\downarrow$ , BLANK = 0, BCXn = 7Fh, OUTTMG = 0	25	50	90	ns
$t_{D5}$		SCKI $\uparrow$ to OUTBn $\uparrow\downarrow$ , BLANK = 0, BCXn = 7Fh, OUTTMG = 1 Or SCKI $\downarrow$ to OUTBn $\uparrow\downarrow$ , BLANK = 0, BCXn = 7Fh, OUTTMG = 0	40	75	120	ns
$t_{D6}^{(2)}$	Last SCKI $\uparrow$ to internal latch pulse generation	$8/f_{OSC}$		$16384/f_{OSC}$	sec	
$t_{W(SCKO)}$	Shift clock output one pulse width	SCKO $\uparrow$ to SCKO $\downarrow$	12	25	35	ns
$f_{OSC}$	Internal oscillator frequency		6	10	12	MHz

(1) The propagation delays are calculated by  $t_{D2} = t_{D0} - t_{D1}$ .

(2) The generation timing of the internal latch pulse changes depending on the SCKI clock frequency; see the [Internal Latch Pulse Generation Timing](#) section.

FUNCTIONAL BLOCK DIAGRAM

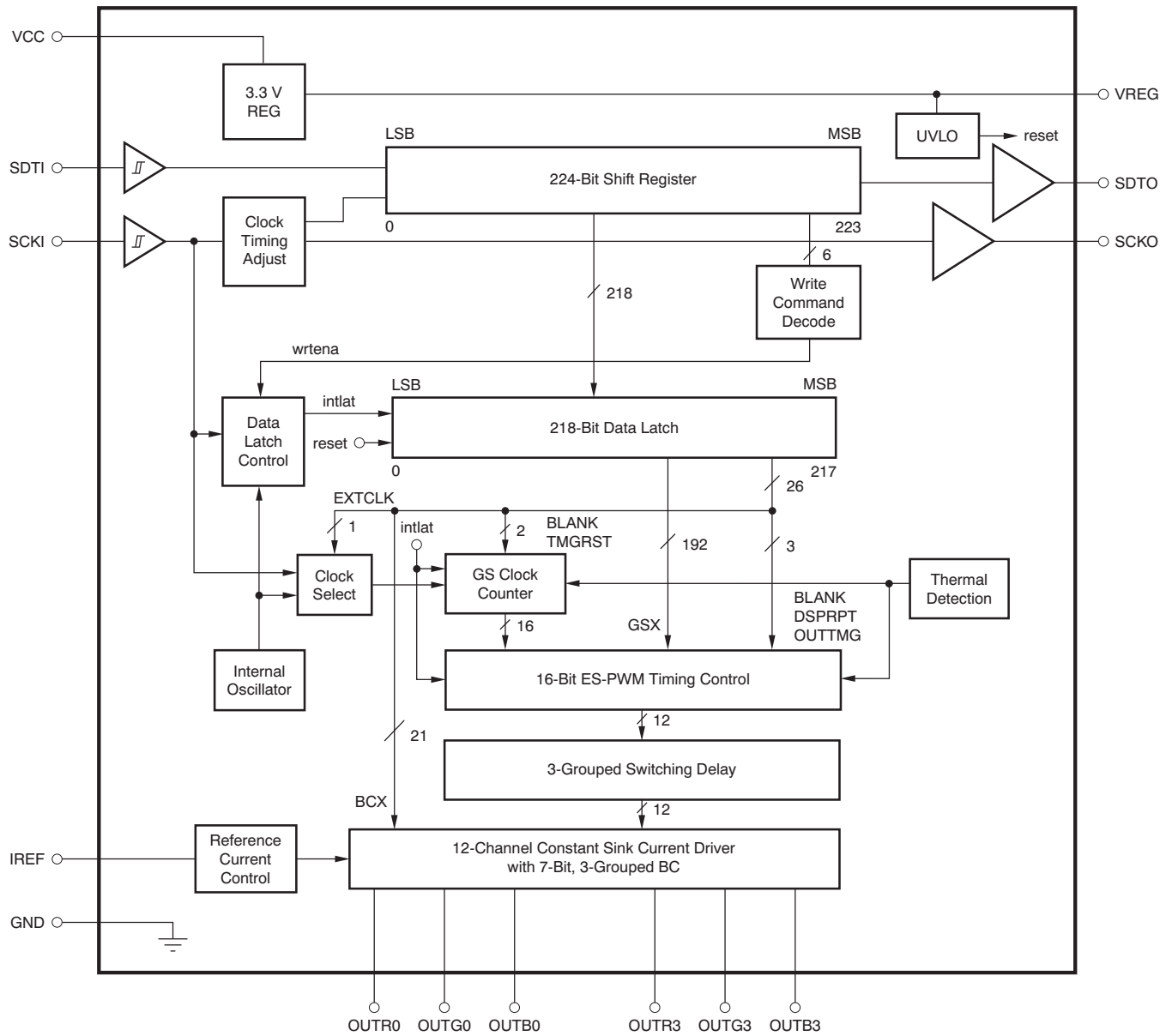

### PIN CONFIGURATIONS

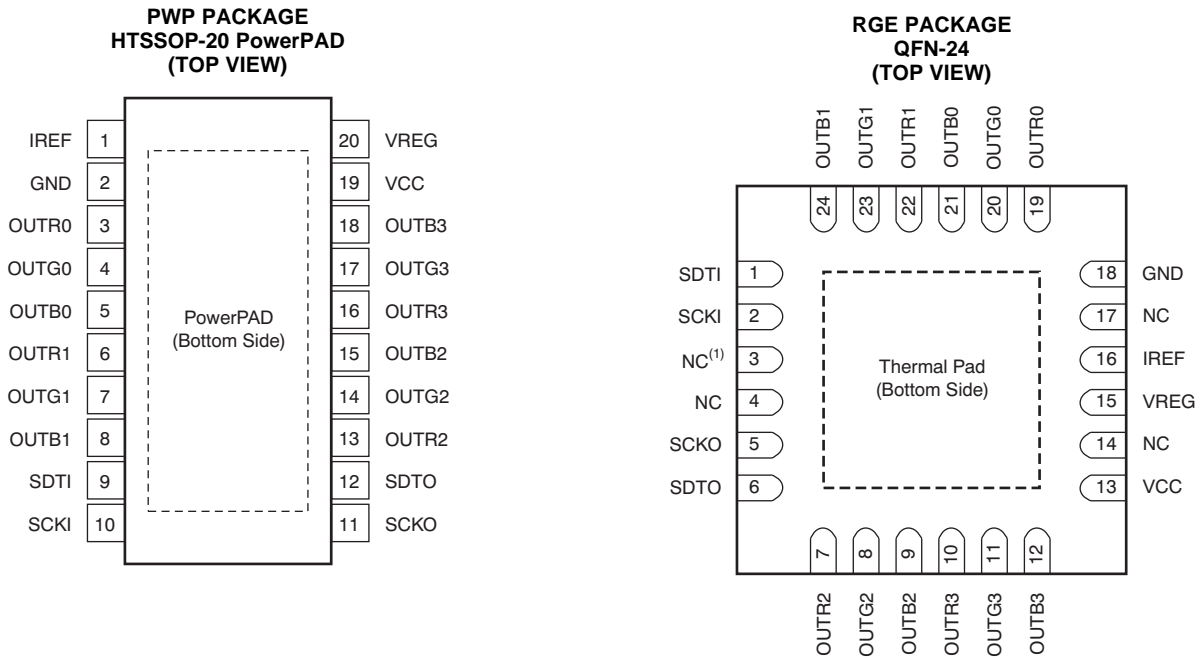

(1) NC = not connected

### TERMINAL FUNCTIONS

TERMINAL		PWP	RGE	I/O	DESCRIPTION
NAME					
SDTI	9	1	I	Serial data input for the 224-bit shift register	
SCKI	10	2	I	Serial data shift clock input. Data present on SDTI are shifted to the LSB of the 224-bit shift register with the SCKI rising edge. Data in the shift register are shifted toward the MSB at each SCKI rising edge. The MSB data of the shift register appear on SDTO.	
SDTO	12	6	O	Serial data output of the 224-bit shift register. SDTO is connected to the MSB of the 224-bit shift register. Data are clocked out at the SCKI rising edge.	
SCKO	11	5	O	Serial data shift clock output. The input shift clock signal from SCKI is adjusted to the timing of the serial data output for SDTO and the signal is then output at SCKO.	
VREG	20	15	I/O	Internal linear voltage regulator output. A decoupling capacitor of 1 $\mu$ F must be connected. This output can be used for external devices as a 3.3-V power supply. This terminal can be connected with the VREG terminal of other devices to increase the supply current. Also, this pin can be supplied with 3 V to 5.5 V from an external power supply by connecting it to VCC.	
IREF	1	16	I/O	Maximum current programming terminal. A resistor connected between IREF and GND sets the maximum current for every constant-current output. When this terminal is directly connected to GND, all outputs are forced off. The external resistor should be placed close to the device.	
OUTR0	3	19	O	RED constant-current outputs. Multiple outputs can be configured in parallel to increase the constant-current capability. Different voltages can be applied to each output.	
OUTR1	6	22	O		
OUTR2	13	7	O		
OUTR3	16	10	O		
OUTG0	4	20	O	GREEN constant-current outputs. Multiple outputs can be configured in parallel to increase the constant-current capability. Different voltages can be applied to each output.	
OUTG1	7	23	O		
OUTG2	14	8	O		
OUTG3	17	11	O		



**TERMINAL FUNCTIONS (continued)**

TERMINAL			I/O	DESCRIPTION
NAME	PWP	RGE		
OUTB0	5	21	O	BLUE constant-current outputs. Multiple outputs can be configured in parallel to increase the constant-current capability. Different voltages can be applied to each output.
OUTB1	8	24	O	
OUTB2	15	9	O	
OUTB3	18	12	O	
VCC	19	13	—	Power-supply terminal
GND, PowerPAD (PWP)	2	—	—	Power ground terminal
GND, exposed thermal pad (RGE)	—	18	—	
NC	—	3, 4, 14, 17	—	No internal connection

**PARAMETRIC MEASUREMENT INFORMATION**

**PIN EQUIVALENT INPUT/OUTPUT SCHEMATICS**

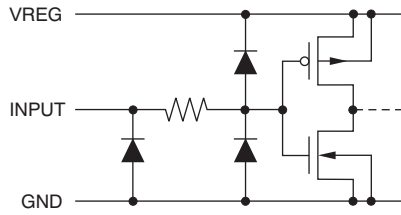

**Figure 1. SDTI/SCKI**

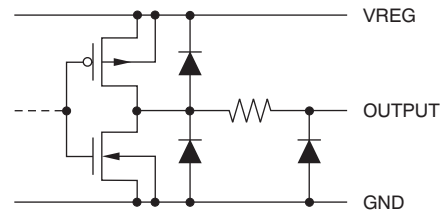

**Figure 2. SDTO/SCKO**

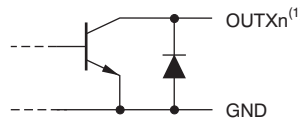

(1) X = R/G/B, n = 0-3.

**Figure 3. OUTR0 Through OUTB3**

**TEST CIRCUITS**

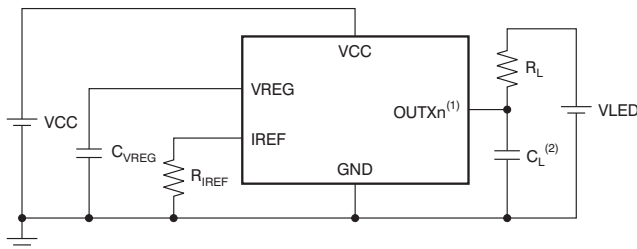

(1) X = R/G/B, n = 0-3.

(2) C<sub>L</sub> includes measurement probe and stray capacitance.

**Figure 4. Rise/Fall Time Test Circuit for OUTXn**

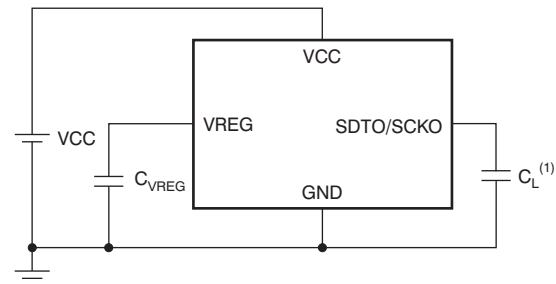

(1) C<sub>L</sub> includes measurement probe and stray capacitance.

**Figure 5. Rise/Fall Time Test Circuit for SDTO/SCKO**

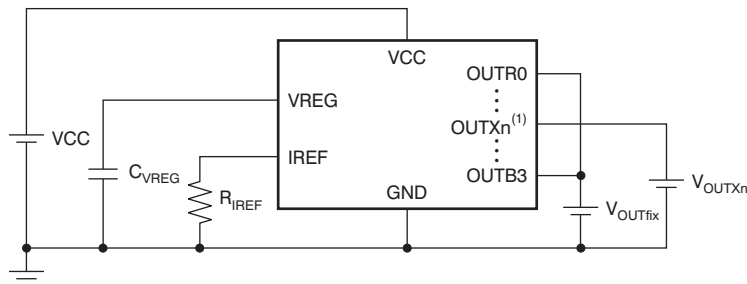

(1) X = R/G/B, n = 0-3.

**Figure 6. Constant-Current Test Circuit for OUTXn**

TIMING DIAGRAMS

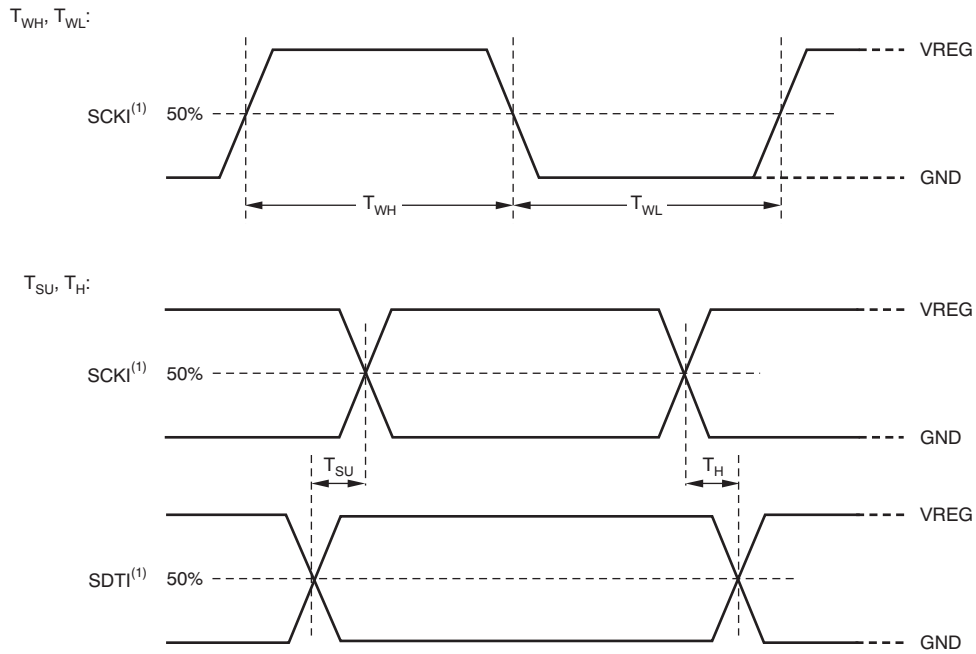

(1) Input pulse rise and fall time is 1ns to 3ns.

Figure 7. Input Timing

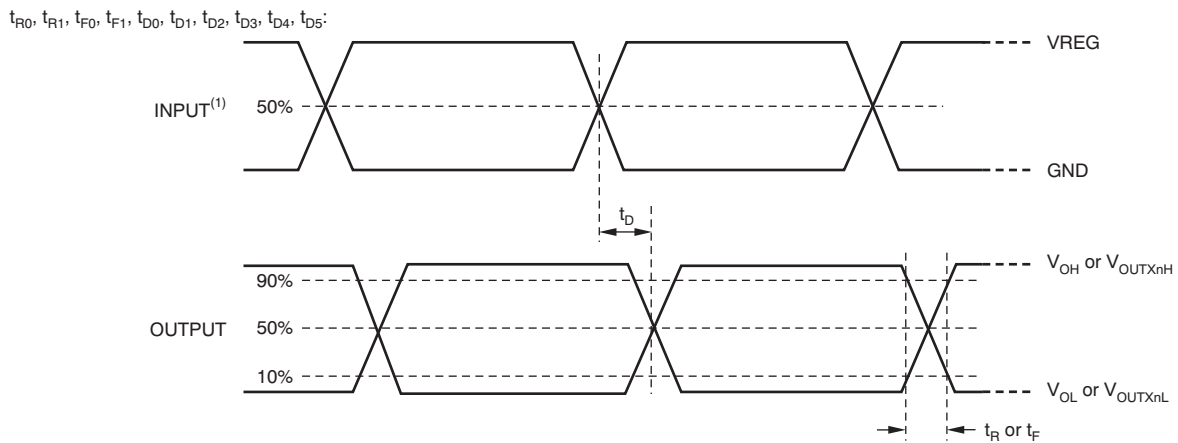

(1) Input pulse rise and fall time is 1ns to 3ns.

Figure 8. Output Timing

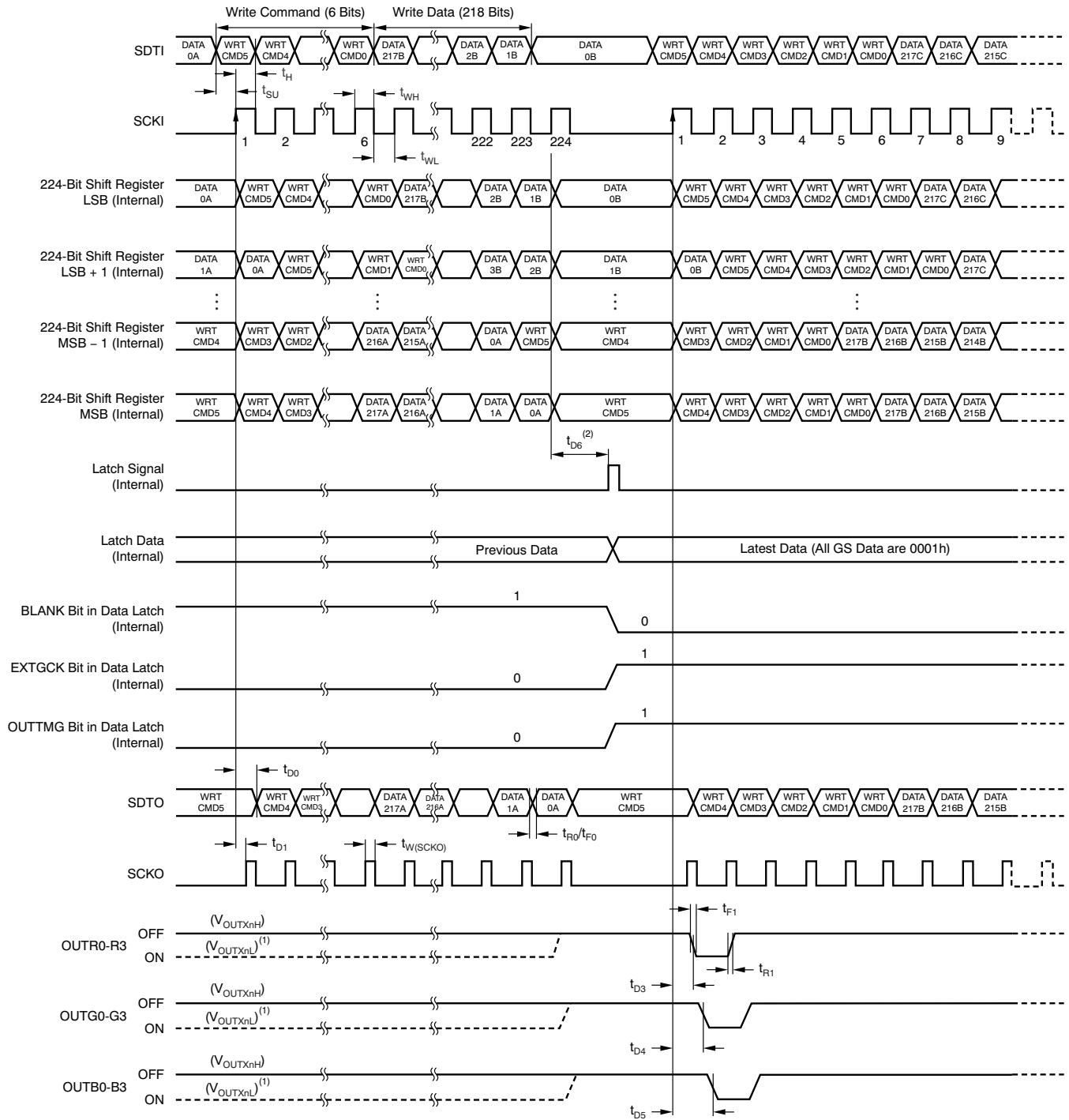

- (1) OUTXn on-off timing depends on previous GS data in the 218-bit data latch.
- (2) The propagation delay time shows the period from the rising edge of the last SCKI, not the 224th SCKI to the internal latch signal generation.

**Figure 9. Data Write and OUTXn Switching Timing (OUTTMG = 1)**

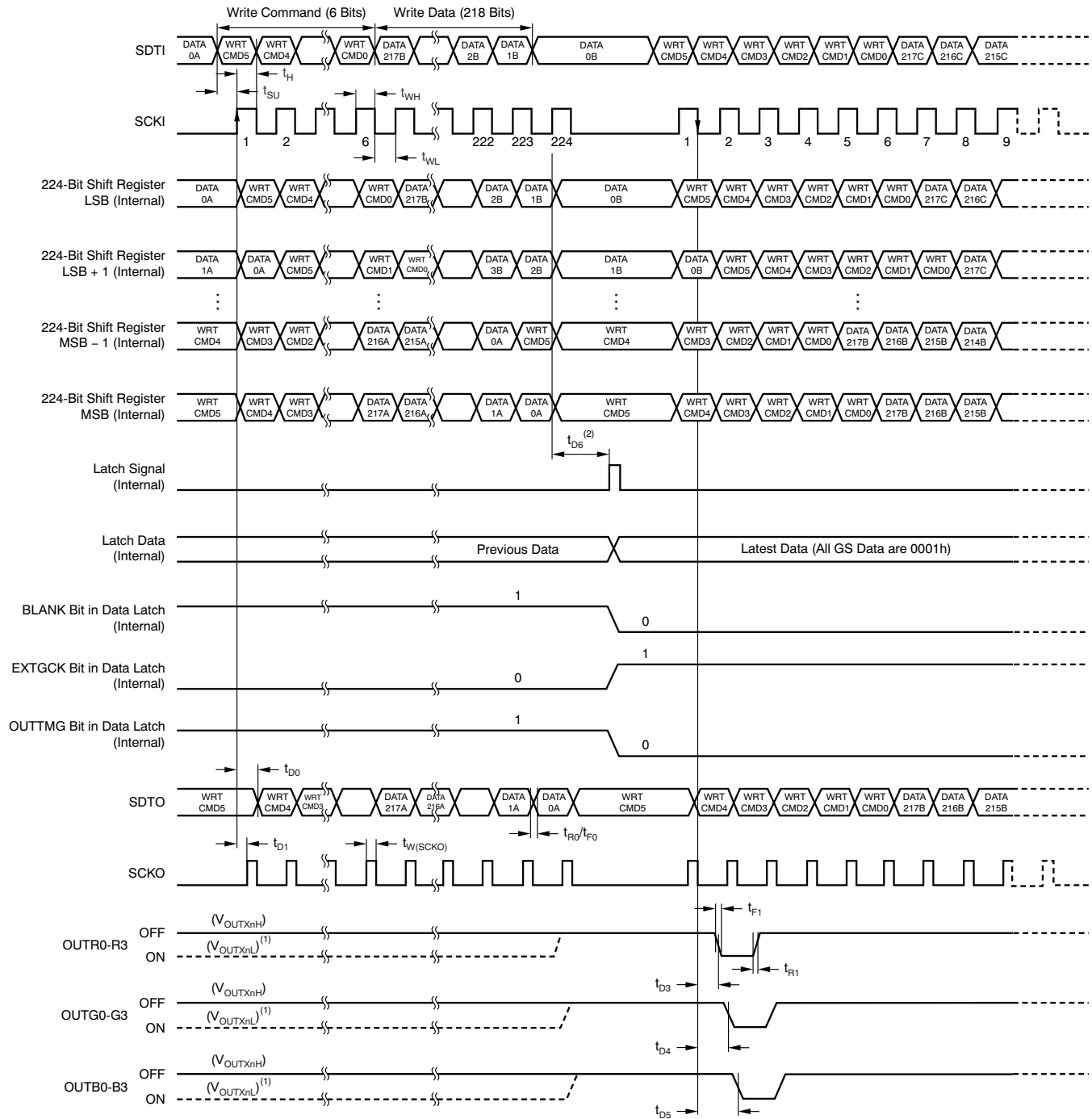

(1) OUTXn on-off timing depends on previous GS data in the 218-bit data latch.

(2) The propagation delay time shows the period from the rising edge of the last SCKI, not the 224th SCKI to the internal latch signal generation.

**Figure 10. Data Write and OUTXn Switching Timing (OUTTMG = 0)**

### TYPICAL CHARACTERISTICS

At  $T_A = +25^\circ\text{C}$  and  $V_{CC} = 24\text{ V}$ , unless otherwise noted.

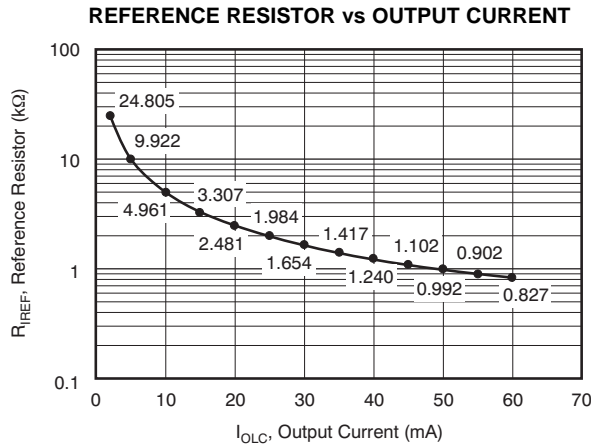

Figure 11.

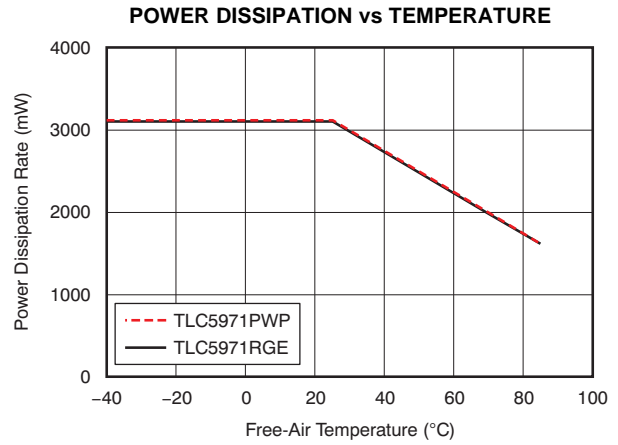

Figure 12.

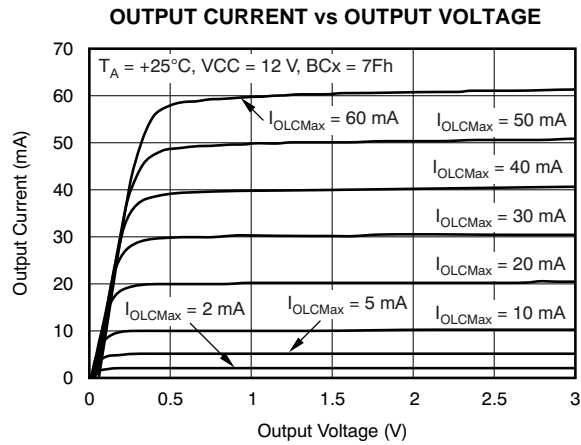

Figure 13.

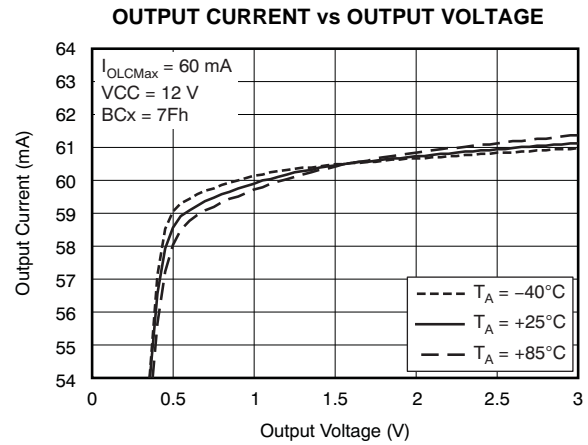

Figure 14.

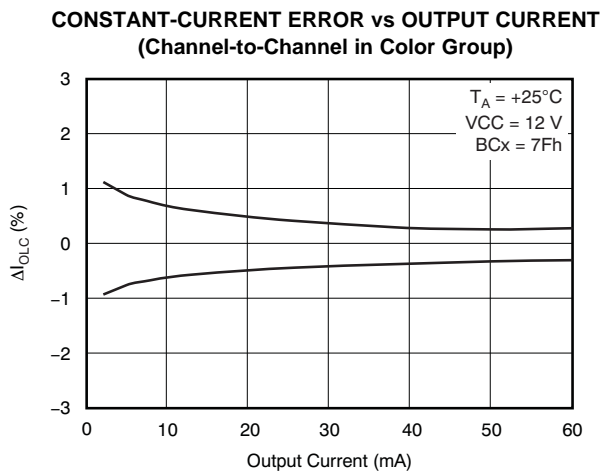

Figure 15.

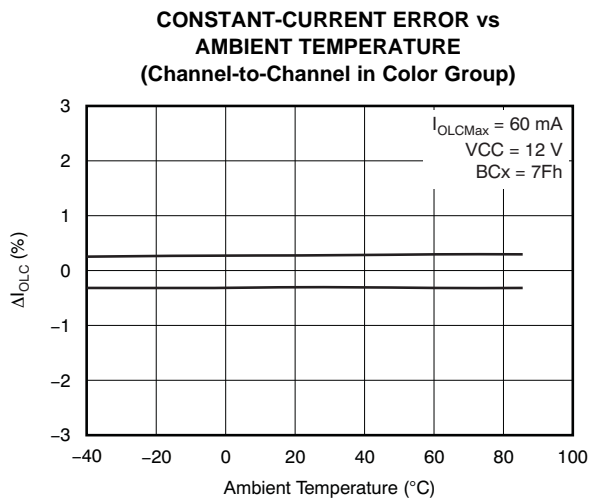

Figure 16.

**TYPICAL CHARACTERISTICS (continued)**

At  $T_A = +25^\circ\text{C}$  and  $V_{CC} = 24\text{ V}$ , unless otherwise noted.

**GLOBAL BRIGHTNESS CONTROL LINEARITY**

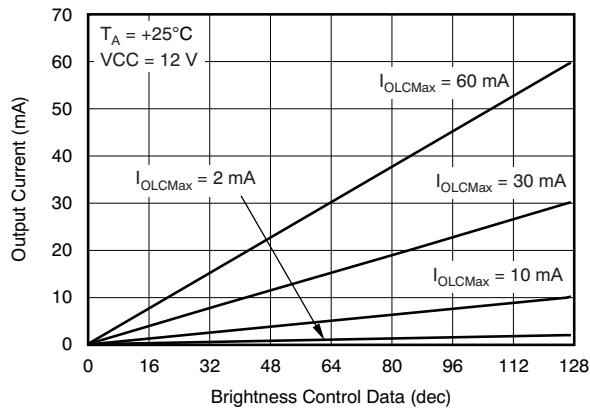

Figure 17.

**SUPPLY CURRENT vs OUTPUT CURRENT**

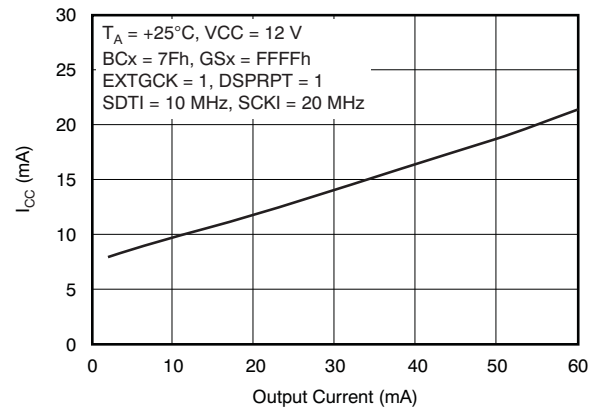

Figure 18.

**SUPPLY CURRENT vs AMBIENT TEMPERATURE**

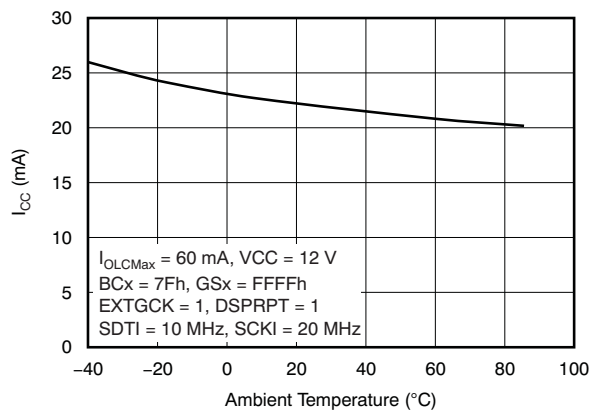

Figure 19.

**LINEAR REGULATOR OUTPUT VOLTAGE vs LINEAR REGULATOR OUTPUT CURRENT**

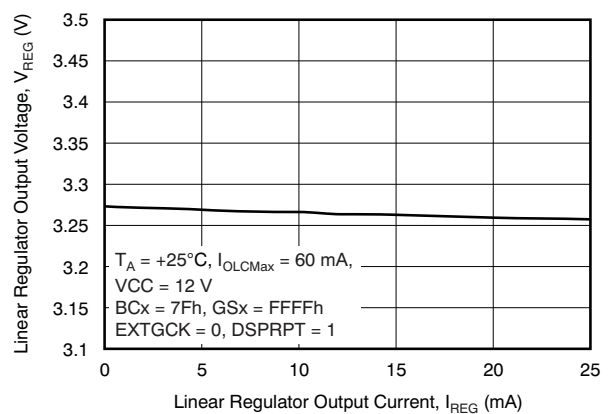

Figure 20.

**LINEAR REGULATOR OUTPUT VOLTAGE vs SUPPLY VOLTAGE**

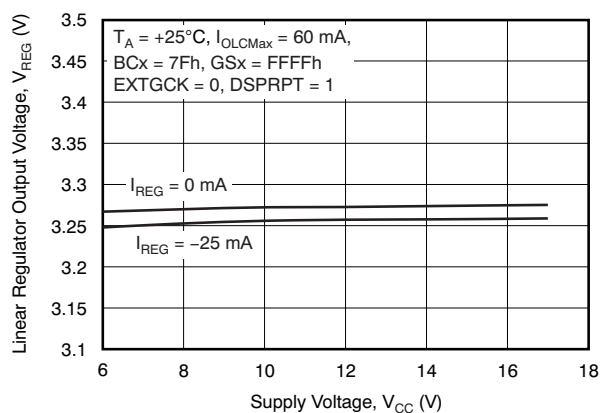

Figure 21.

**CONSTANT-CURRENT OUTPUT VOLTAGE WAVEFORM**

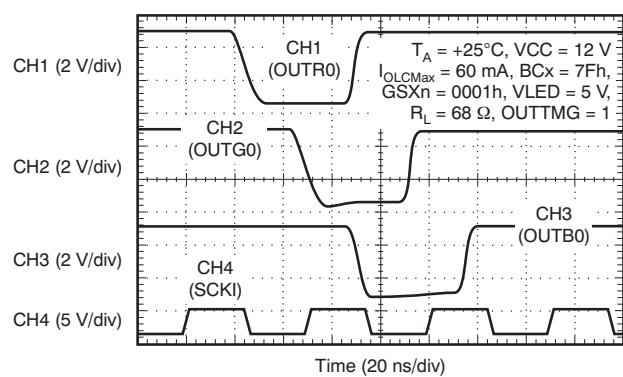

Figure 22.

## APPLICATION INFORMATION

### MAXIMUM CONSTANT SINK CURRENT SETTING

The maximum constant sink current value for each channel,  $I_{OLCMax}$ , is programmed through a single resistor,  $R_{IREF}$ , placed between IREF and GND. The desired value can be calculated with [Equation 1](#):

$$R_{IREF} (k\Omega) = \frac{V_{IREF} (V)}{I_{OLCMax} (mA)} \times 41$$

Where:

$V_{IREF}$  = the internal reference voltage on the IREF pin (1.21 V, typically, when the the global brightness control data are at maximum),

$I_{OLCMax}$  = 2 mA to 60 mA. (1)

$I_{OLCMax}$  is the maximum current for each output. Each output sinks the  $I_{OLCMax}$  current when it is turned on and global brightness control data (BC) are set to the maximum value of 7Fh (127d).

$R_{IREF}$  must be between 0.82 k $\Omega$  and 24.8 k $\Omega$  to hold  $I_{OLCMax}$  between 60 mA (typical) and 2 mA (typical). Otherwise, the output may be unstable. Output currents lower than 2 mA can be achieved by setting  $I_{OLCMax}$  to 2 mA or higher and then using global brightness control to lower the output current. The constant-current sink values for specific external resistor values are shown in [Figure 11](#) and [Table 1](#).

**Table 1. Maximum Constant-Current versus External Resistor Value**

$I_{OLCMax}$ (mA)	$R_{IREF}$ (k $\Omega$ , Typical)
60	0.827
55	0.902
50	0.992
45	1.1
40	1.24
35	1.42
30	1.65
25	1.98
20	2.48
15	3.31
10	4.96
5	9.92
2	24.8



## GLOBAL BRIGHTNESS CONTROL (BC) FUNCTION (SINK CURRENT CONTROL)

The TLC5971 has the capability to adjust all output currents of each color group (OUTR0-3, OUTG0-3, and OUTB0-3) to the same current value. This function is called *global brightness (BC) control*. The BC data are seven bits long, which allows each color group output current to be adjusted in 128 steps from 0% to 100% of the maximum output current,  $I_{OLCMax}$ . The BC data are set via the serial interface. When the BC data are changed, the output current is changed immediately.

When the IC is powered on, all outputs are forced off by BLANK (bit 213). BLANK initializes in the data latch but the data in the 224-bit shift register and the 218-bit data latch are not set to a default value, except for the BLANK bit. Therefore, BC data must be written to the data latch when BLANK is set to '0'.

Equation 2 determines each color group maximum output sink current:

$$I_{OUT} \text{ (mA)} = I_{OLCMax} \text{ (mA)} \times \left( \frac{BCX}{127d} \right)$$

Where:

$I_{OLCMax}$  = the maximum channel current for each channel determined by  $R_{IREF}$

BC = the global brightness control value in the data latch for the specific color group

(BCX = 0d to 127d, X = R/G/B)

(2)

Table 2 summarizes the BC data value versus the output current ratio and set current value.

**Table 2. BC Data versus Current Ratio and Set Current Value**

BC DATA (Binary)	BC DATA (Decimal)	BC DATA (Hex)	OUTPUT CURRENT RATIO TO $I_{OLCMax}$ (% , Typical)	60 mA $I_{OLCMax}$ (mA, Typical)	2 mA $I_{OLCMax}$ (mA, Typical)
000 0000	0	00	0	0	0
000 0001	1	01	0.8	0.47	0.02
000 0010	2	02	1.6	0.94	0.03
—	—	—	—	—	—
111 1101	125	7D	98.4	59.06	1.97
111 1110	126	7E	99.2	59.53	1.98
111 1111	127	7F	100	60	2

## GRAYSCALE (GS) FUNCTION (PWM CONTROL)

The TLC5971 can adjust the brightness of each output channel using the enhanced spectrum pulse width modulation (ES-PWM) control scheme. The PWM bit length for each output is 16 bits. The use of the 16-bit length results in 65536 brightness steps from 0% to 100% brightness.

The PWM operation for all color groups is controlled by a 16-bit grayscale (GS) counter. The GS counter increments on each rising or falling edge of the external or internal GS reference clock that is selected by OUTTMG (bit 217) and EXTGCK (bit 216) in the data latch. When the external GS clock is selected, the GS counter uses the SCKI clock as the grayscale clock. The GS counter is reset to 0000h and all outputs are forced off when BLANK (bit 213) is set to '1' in the data latch and the counter value is held at '0' while BLANK is '1', even if the GS reference clock is toggled in between.

**Equation 3** calculates each output (OUTXn) total on-time ( $t_{OUT\_ON}$ ):

$$t_{OUT\_ON} \text{ (ns)} = t_{GSCLK} \text{ (ns)} \times GSXn$$

Where:

$t_{GSCLK}$  = one period of the selected GS reference clock

(internal clock = 100ns typical, external clock = the period of SCKI)

GSXn = the programmed GS value for OUTXn (0d to 65535d) (3)

**Table 3** summarizes the GS data values versus the output total on-time and duty cycle. When the IC is powered up, BLANK (bit 213) is set to '1' to force all outputs off; however, the 224-bit shift register and the 218-bit data latch are not set to default values. Therefore, the GS data must be written to the data latch when BLANK (bit 213) is set to '0'.

**Table 3. Output Duty Cycle and Total On-Time versus GS Data**

GS DATA (decimal)	GS DATA (hex)	ON-TIME DUTY (%)	GS DATA (decimal)	GS DATA (hex)	ON-TIME DUTY (%)
0	0	0	32768	8000	50.001
1	1	0.002	32769	8001	50.002
2	2	0.003	32770	8002	50.004
3	3	0.005	32771	8003	50.005
—	—	—	—	—	—
8191	1FFF	12.499	40959	9FFF	62.499
8192	2000	12.5	40960	A000	62.501
8193	2001	12.502	40961	A001	62.502
—	—	—	—	—	—
16383	3FFF	24.999	49149	BFFF	74.997
16384	4000	25	49150	C000	74.998
16385	4001	25.002	49151	C001	75
—	—	—	—	—	—
24575	5FFF	37.499	57343	DFFF	87.5
24576	6000	37.501	57344	E000	87.501
24577	6001	37.502	57345	E001	87.503
—	—	—	—	—	—
32765	7FFD	49.996	65533	FFFD	99.997
32766	7FFE	49.998	65534	FFFE	99.998
32767	7FFF	49.999	65535	FFFF	100

## ENHANCED SPECTRUM (ES) PWM CONTROL

Enhanced spectrum (ES) PWM has the total display period divided into 128 display segments. The total display period refers the period between the first grayscale clock input to the 65536th grayscale clock input after BLANK (bit 213) is set to '0'. Each display period has 512 grayscale values, maximum. Each output on-time changes depending on the grayscale data. Refer to [Table 4](#) for sequence information and [Figure 23](#) for timing information.

**Table 4. ES-PWM Drive Turn-On Time Length**

GS DATA (dec)	GS DATA (hex)	OUTn DRIVER OPERATION
0	0000h	Does not turn on
1	0001h	Turns on during one GS clock period in the 1st display period
2	0002h	Turns on during one GS clock period in the 1st and 65th display period
3	0003h	Turns on during one GS clock period in the 1st, 33rd, and 65th display period
4	0004h	Turns on during one GS clock period in the 1st, 33rd, 65th, and 97th display period
5	0005h	Turns on during one GS clock period in the 1st, 17th, 33rd, 65th, and 97th display period
6	0006h	Turns on during one GS clock period in the 1st, 17th, 33rd, 65th, 81st, and 97th display period
—	—	The number of display periods that OUTXn is turned on during one GS clock is incremented by the GS data increasing in the following order. The order of display periods that the output turns on are: 1, 65, 33, 97, 17, 81, 49, 113, 9, 73, 41, 105, 25, 89, 57, 121, 5, 69, 37, 101, 21, 85, 53, 117, 13, 77, 45, 109, 29, 93, 61, 125, 3, 67, 35, 99, 19, 83, 51, 115, 11, 75, 43, 107, 27, 91, 59, 123, 7, 71, 39, 103, 23, 87, 55, 119, 15, 79, 47, 111, 31, 95, 63, 127, 2, 66, 34, 98, 18, 82, 50, 114, 10, 74, 42, 106, 26, 90, 58, 122, 6, 70, 38, 102, 22, 86, 54, 118, 14, 78, 46, 110, 30, 94, 62, 126, 4, 68, 36, 100, 20, 84, 52, 116, 12, 76, 44, 108, 28, 92, 60, 124, 8, 72, 40, 104, 24, 88, 56, 120, 16, 80, 48, 112, 32, 96, 64, and 128.
127	007Fh	Turns on during one GS clock period in the 1st to 127th display period, but does not turn on in the 128th display period
128	0080h	Turns on during one GS clock period in all display periods (1st to 128th)
129	0081h	Turns on during two GS clock periods in the 1st display period and one GS clock period in the next display period
—	—	The number of display periods where OUTn is turned on for two GS clocks is incremented by the increased GS data similar to the previous case where the GS value is 1 through 127
255	00FFh	Turns on during two GS clock periods in the 1st to 127th display period, but only turns on during one GS clock period in the 128th display period
256	0100h	Turns on during two GS clock periods in all display periods (1st to 128th)
257	0101h	Turns on during three GS clock periods in the 1st display period and two GS clock periods in the next display period
—	—	Display periods with OUTn turned on is incremented by the increased GS data similar to 0101h operation
65478	FEFFh	Turns on during 511 GS clock periods in the 1st to 127th display period, but only turns on 510 GS clock periods in the 128th display period
65280	FF00h	Turns on during 511 GS clock periods in all display periods (1st to 128th)
65281	FF01h	Turns on during 512 GS clock periods in the 1st display period and 511 GS clock periods in the 2nd to 128th display periods
—	—	—
65534	FFFEh	Turns on during 512 GS clock periods in the 1st to 63th and 65th to 127th display periods, and turns on 511 GS clock periods in the 64th and 128th display periods
65535	FFFFh	Turns on during 512 GS clock periods in the 1st to 127th display period, but only turns on 511 GS clock periods in the 128th display period

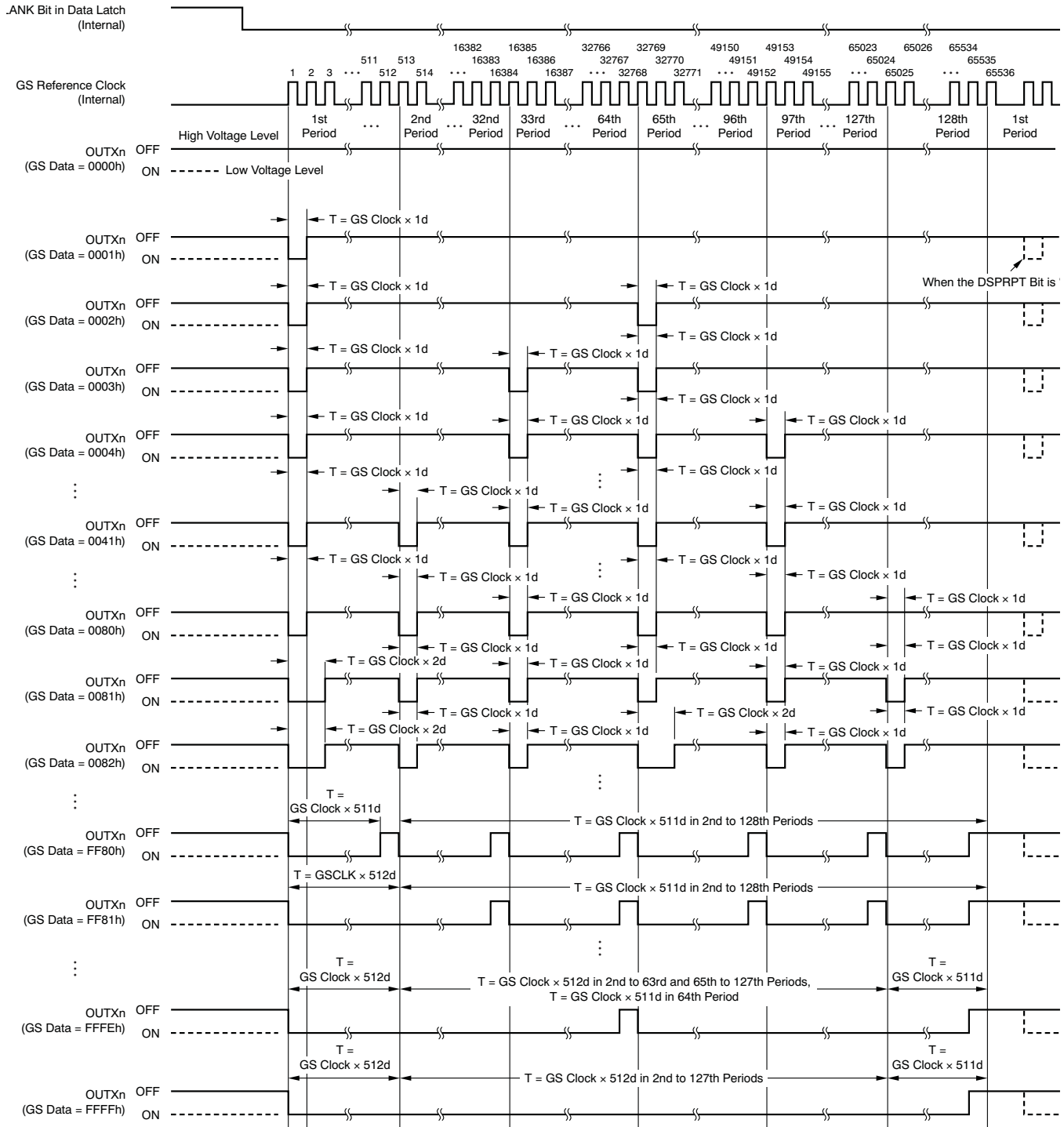

Figure 23. ES-PWM Operation

## REGISTER AND DATA LATCH CONFIGURATION

The TLC5971 has a 224-bit shift register and a 218-bit data latch that set grayscale (GS) data, global brightness control (BC), and function control (FC) data into the device. When the internal latch pulse is generated and the data of the six MSBs in the shift register are 25h, the 218 following data bits in the shift register are copied into the 218-bit data latch. If the data of the six MSBs is not 25h, the 218 data bits are not copied into the 218-bit data latch. The data in the data latch are used for GS, BC, and FC functions. Figure 24 shows the shift register and the data latch configuration.

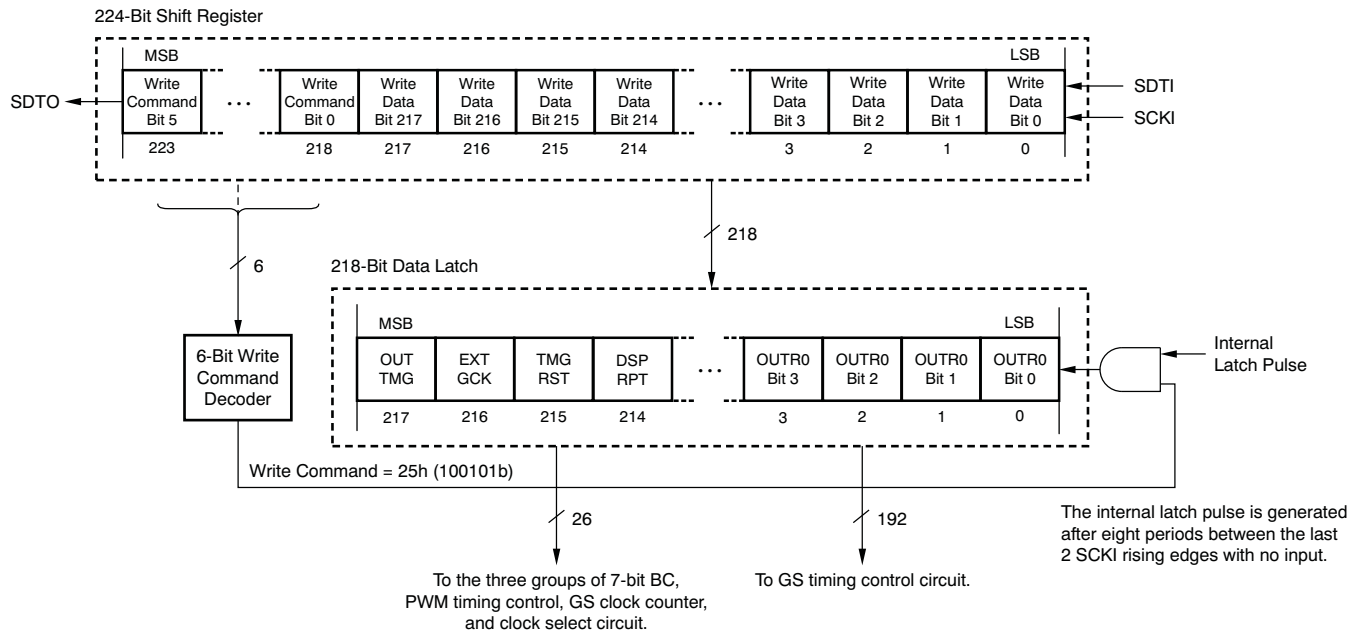

Figure 24. Common Shift Register and Control Data Latch Configuration

### 224-Bit Shift Register

The 224-bit shift register is used to input data from the SCKI pin with the SCKI clock into the TLC5971. The shifted data in this register is used for GS, BC, and FC. The six MSBs are used for the write command. The LSB of the register is connected to the SCKI pin and the MSB is connected to the SDTO pin. On each SCKI rising edge, the data on SCKI are shifted into the register LSB and all 224 bits are shifted towards the MSB. The register MSB is always connected to SDTO. When the device is powered up, the data in the 224-bit shift register is not set to any default value.

### 218-Bit Data Latch

The 218-bit data latch is used to latch the GS, BC, and FC data. The 218 LSBs in the 244-bit shift register are copied to the data latch when the internal latch pulse is generated with the 6-bit write command, 25h (100101b). When the device is powered up, the data in the latch are not reset except for BLANK (bit 213) which is set to '1' to force all outputs off. Therefore, GS, BC, and FC data must be set to the proper values before BLANK is set to '0'. The 218-bit data latch configuration is shown in Figure 25 and the data bit assignment is shown in Table 5.

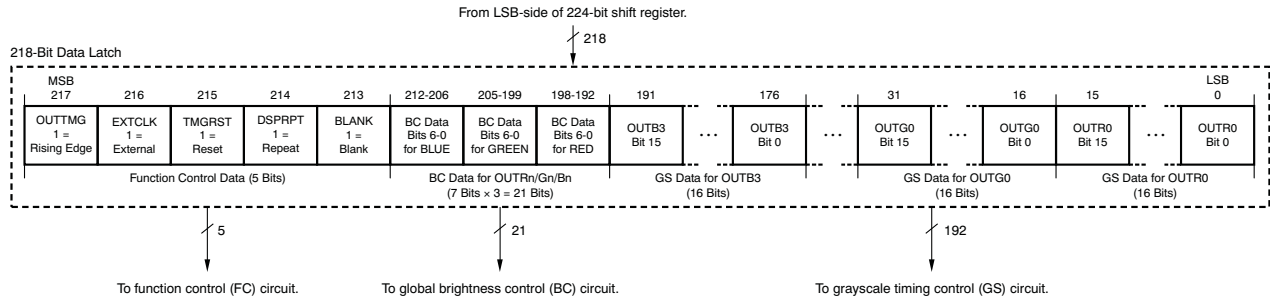

Figure 25. 218-Bit Data Latch Configuration

Table 5. Data Latch Bit Assignment

BIT NUMBER	BIT NAME	CONTROLLED CHANNEL/FUNCTIONS
15-0	GSR0	GS data bits 15 to 0 for OUTR0
31-16	GSG0	GS data bits 15 to 0 for OUTG0
47-32	GSB0	GS data bits 15 to 0 for OUTB0
63-48	GSR1	GS data bits 15 to 0 for OUTR1
79-64	GSG1	GS data bits 15 to 0 for OUTG1
95-80	GSB1	GS data bits 15 to 0 for OUTB1
111-96	GSR2	GS data bits 15 to 0 for OUTR2
127-112	GSG2	GS data bits 15 to 0 for OUTG2
143-128	GSB2	GS data bits 15 to 0 for OUTB2
159-144	GSR3	GS data bits 15 to 0 for OUTR3
175-160	GSG3	GS data bits 15 to 0 for OUTG3
191-176	GSB3	GS data bits 15 to 0 for OUTB3
198-192	BCR6-0	BC data bits 6 to 0 for OUTR0-3
205-199	BCG6-0	BC data bits 6 to 0 for OUTG0-3
212-206	BCB6-0	BC data bits 6 to 0 for OUTB0-3
213	BLANK	Constant-current output enable bit in FC data (0 = output control enabled, 1 = blank). When this bit is '0', all constant-current outputs (OUTR0-OUTB3) are controlled by the GS PWM timing controller. When this bit is '1', all constant-current outputs are forced off. The GS counter is reset to '0', and the GS PWM timing controller is initialized. When the IC is powered on, this bit is set to '1'.
214	DSPRPT	Auto display repeat mode enable bit in FC data (0 = disabled, 1 = enabled). When this bit is '0', the auto repeat function is disabled. Each constant-current output is only turned on once, according the GS data after BLANK is set to '0' or after the internal latch pulse is generated with the TMGRST bit set to '1'. When this bit is '1', each output turns on and off according to the GS data every 65536 GS reference clocks.
215	TMGRST	Display timing reset mode enable bit in FC data (0 = disabled, 1 = enabled). When this bit is '1', the GS counter is reset to '0' and all constant-current outputs are forced off when the internal latch pulse is generated for data latching. This function is the same when BLANK is set to '0'. Therefore, BLANK does not need to be controlled by an external controller when this mode is enabled. When this bit is '0', the GS counter is not reset and no output is forced off even if the internal latch pulse is generated.
216	EXTGCK	GS reference clock select bit in FC data (0 = internal oscillator clock, 1 = SCKI clock). When this bit is '1', PWM timing refers to the SCKI clock. When this bit is '0', PWM timing refers to the internal oscillator clock.
217	OUTTMG	GS reference clock edge select bit for OUTXn on-off timing contro in FC datal (0 = falling edge, 1 = rising edge). When this bit is '1', OUTXn are turned on or off at the rising edge of the selected GS reference clock. When this bit is '0', OUTXn are turned on or off at the falling edge of the selected clock.

## INTERNAL LATCH PULSE GENERATION TIMING

The internal latch pulse is generated when the SCKI rising edge does not change for 8x the period between the last SCKI rising edge and the second to last SCKI rising edge if the data of the six MSBs in the 244-bit shift register are the command code 25h. The generation timing changes as a result of the SCKI frequency with the time range between 16384 times the internal oscillator period (2.74ms), maximum, and 8x the internal oscillator period (666 ns), minimum. Figure 26 shows the internal latch pulse generation timing.

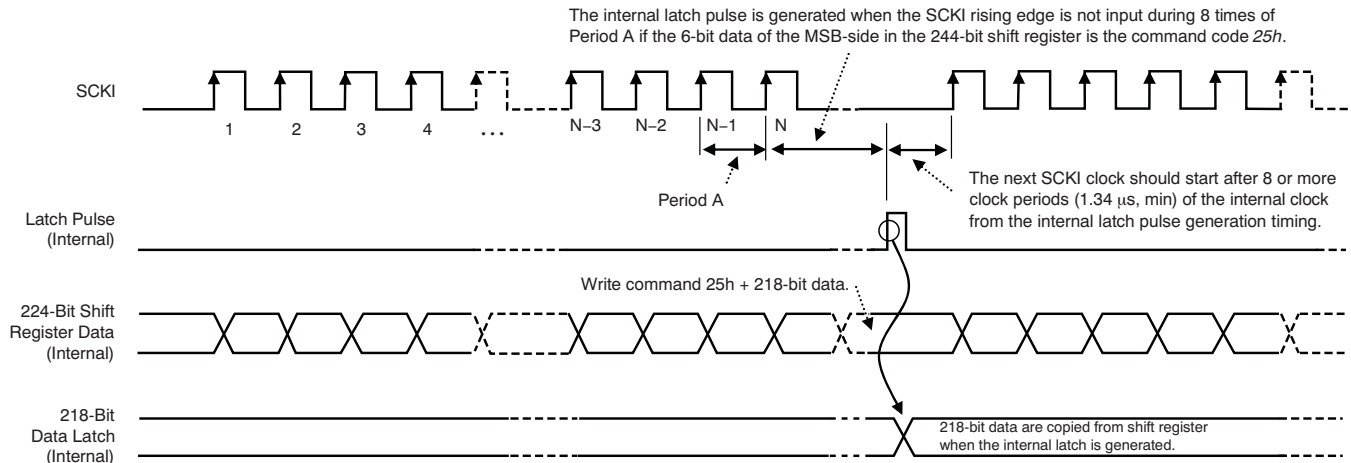

Figure 26. Data Latch Pulse Generation Timing

## AUTO DISPLAY REPEAT FUNCTION

This function repeats the total display period without a BLANK bit change, as long as the GS reference clock is available. This function can be enabled or disabled with DSPRPT (bit 214) in the data latch. When the DSPRPT bit is '1', this function is enabled and the entire display period repeats without a BLANK bit data change. When the DSPRPT bit is '0', this function is disabled and the entire display period executes only once after the BLANK bit is set to '0' or the internal latch pulse is generated when the display timing reset function is enabled. Figure 27 shows the auto display repeat operation timing.

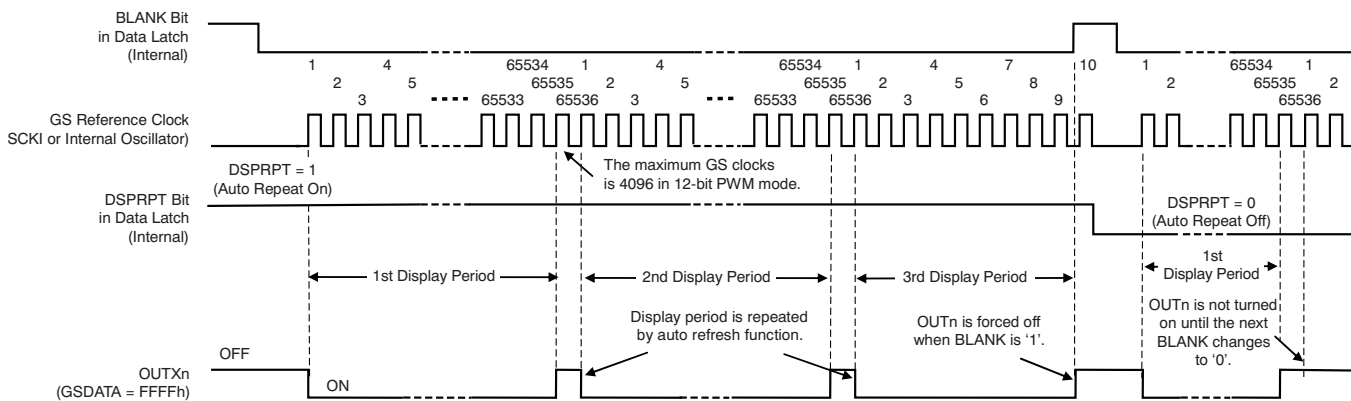

Figure 27. Auto Repeat Display Function

### DISPLAY TIMING RESET FUNCTION

This function allows the display timing to be initialized using the internal latch pulse, as shown in Figure 28. This function can be enabled or disabled by TMGRST (bit 215) in the data latch. When the TMGRST bit is '1', the GS counter is reset to '0' and all outputs are forced off when the internal latch pulse is generated. This function is the same when the BLANK bit changes (such as from '0' to '1' and from '1' to '0'). Therefore, the BLANK bit does not need to be controlled from an external controller to restart the PWM control from the next GS reference clock rising edge. When this bit is '0', the GS counter is not reset and no output is forced off even if the internal latch pulse is generated. Figure 28 shows the display timing reset operation.

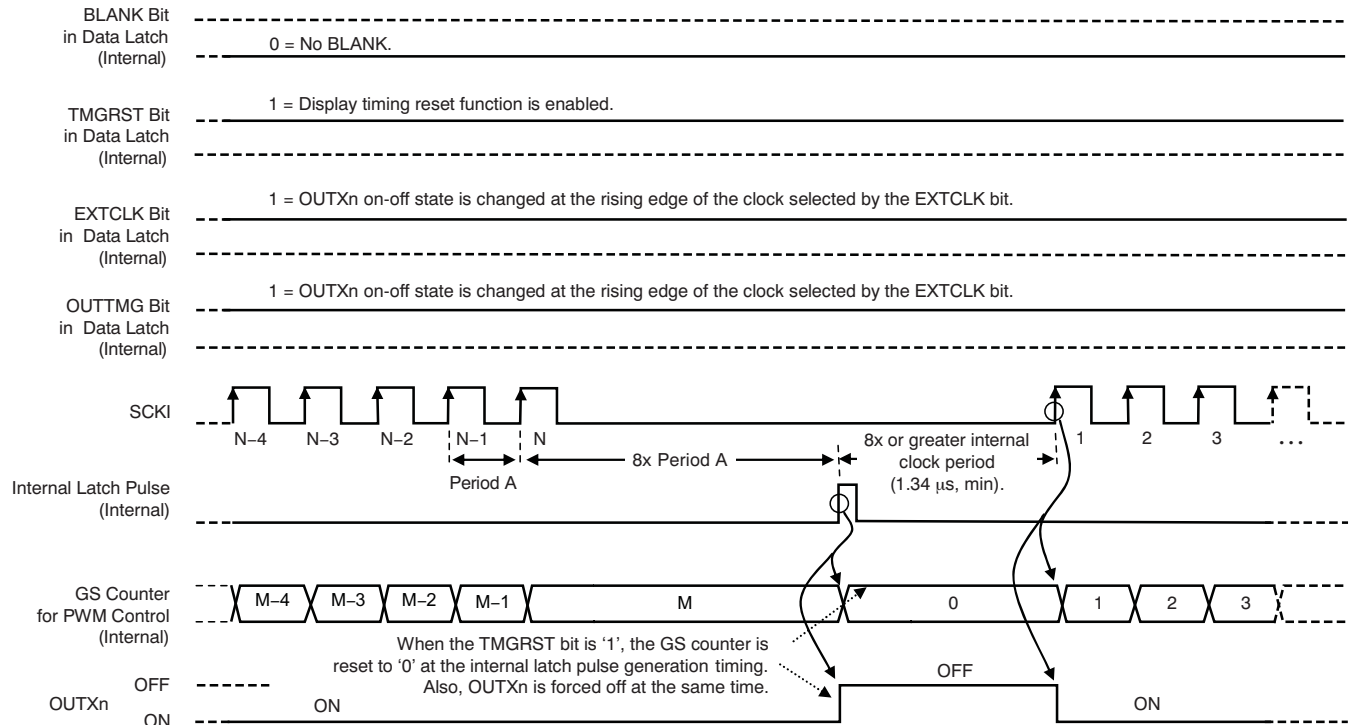

Figure 28. Display Timing Reset Function

### OUTPUT TIMING SELECT FUNCTION

This function selects the on-off change timing of the constant-current outputs (OUTXn) set by OUTTMG (bit 217) in the data latch. When this bit is '1', OUTXn are turned on or off at the rising edge of the selected GS reference clock. When this bit is '0', OUTXn are turned on or off at the falling edge of the selected clock. Electromagnetic interference (EMI) of the total system can be reduced using this bit setting. For example, when the odd number of devices in the system have this bit set to '0' and the even number of devices in the system have this bit set to '1', EMI is reduced because the devices change the OUTXn status at a deferent timing. Figure 29 and Figure 30 show the output switching timing when the OUTTMG bit is '1' and '0', respectively.



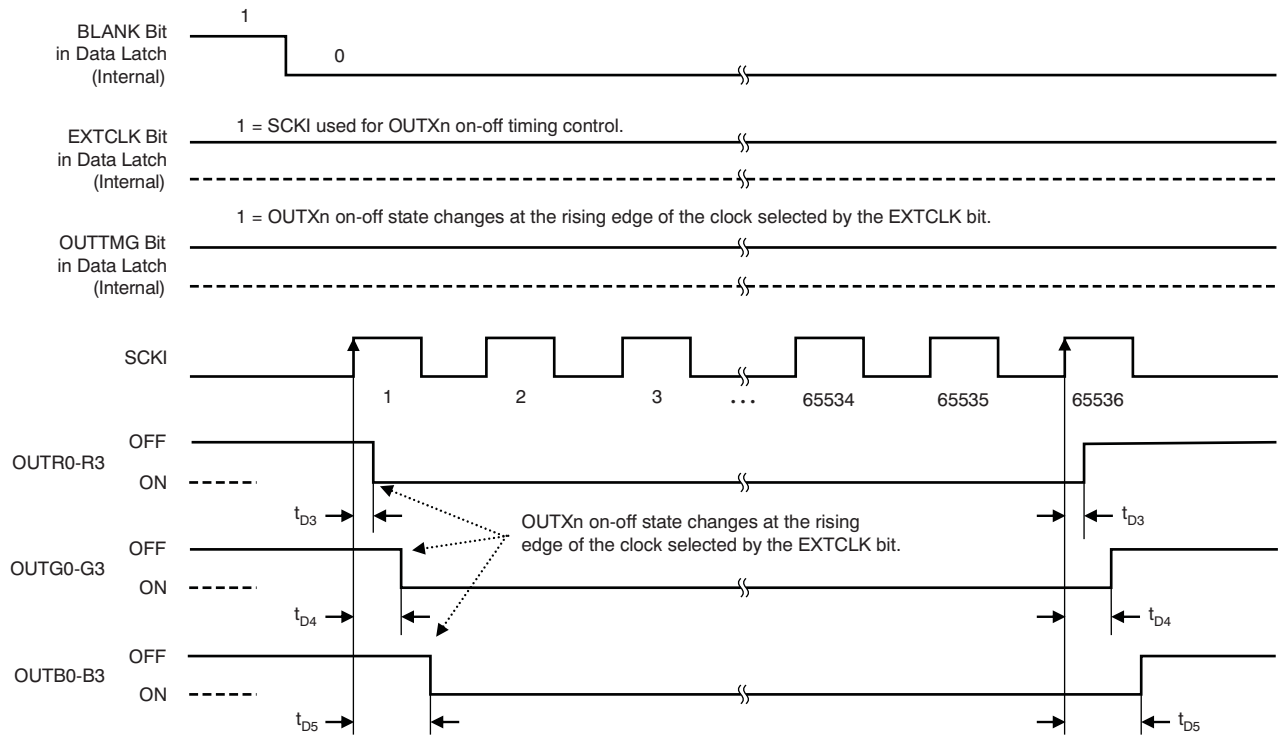

Figure 29. Output On-Off Timing with Four-Channel Grouped Delay (OUTTMG = 1)

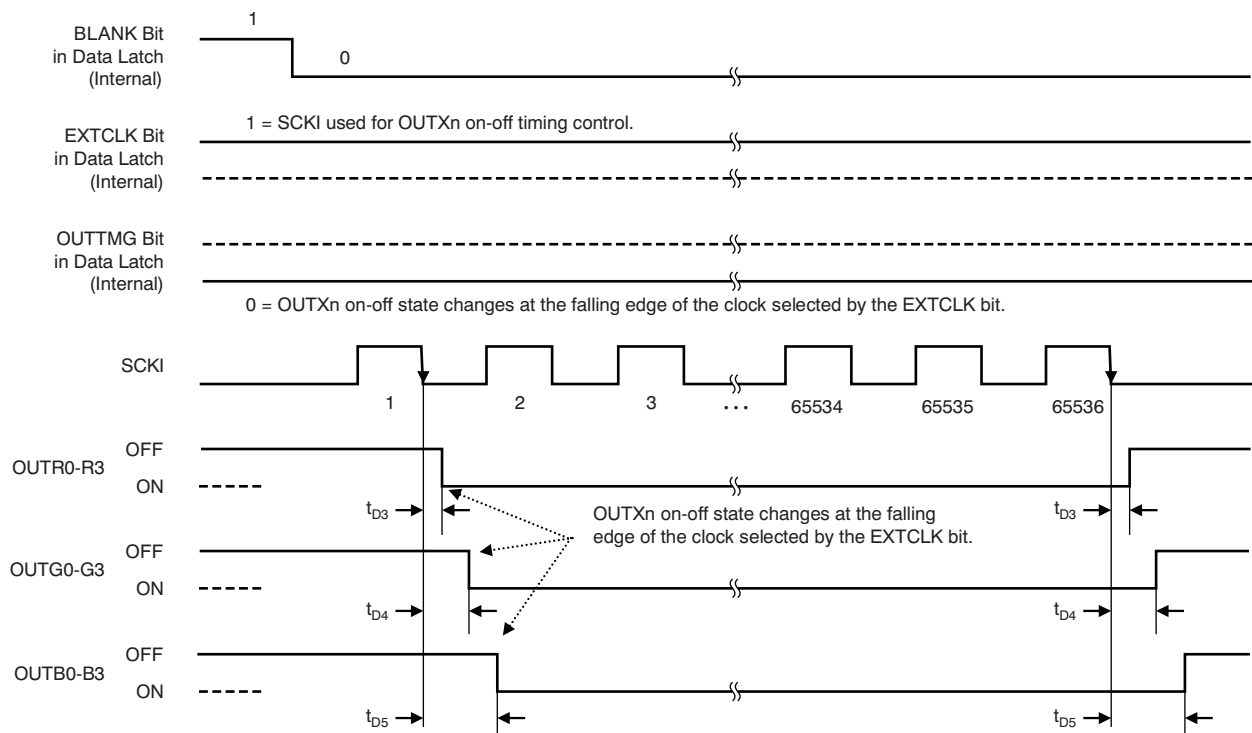
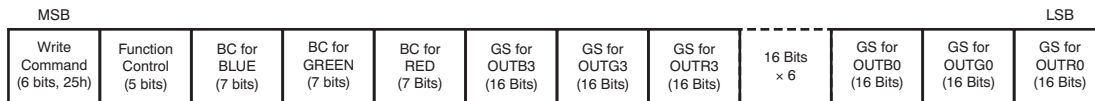

Figure 30. Output On-Off Timing with Four-Channel Grouped Delay (OUTTMG = 0)

## HOW TO CONTROL THE TLC5971

To set each function mode, BC color, GS output, 6-bit write command, 5-bit FC data, 21-bit BC data for each color group, and 192-bit GS data for OUTXn, a total number of 224 bits must be written into the device. Figure 31 shows the 224-bit data packet configuration.

When  $N$  units of the TLC5971 are cascaded (as shown in Figure 32),  $N \times 224$  bits must be written from the controller into the first device to control all devices. The number of cascaded devices is not limited as long as the proper voltage is supplied to the device at VCC. The packets for all devices must be written again whenever the data in one packet is changed.



**Figure 31. 224-Bit Data Packet Configuration**

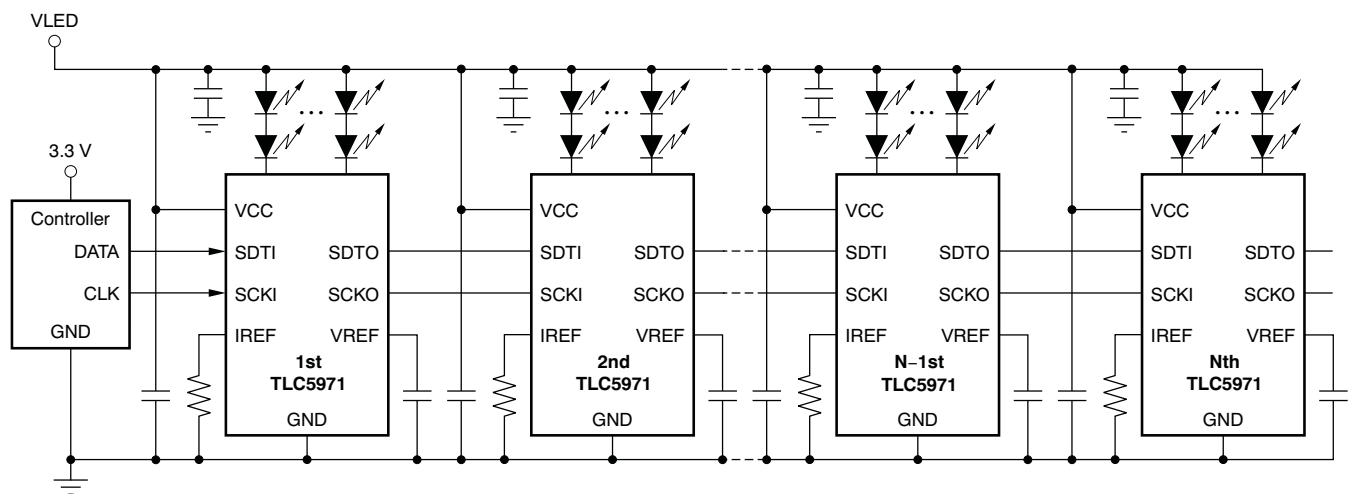
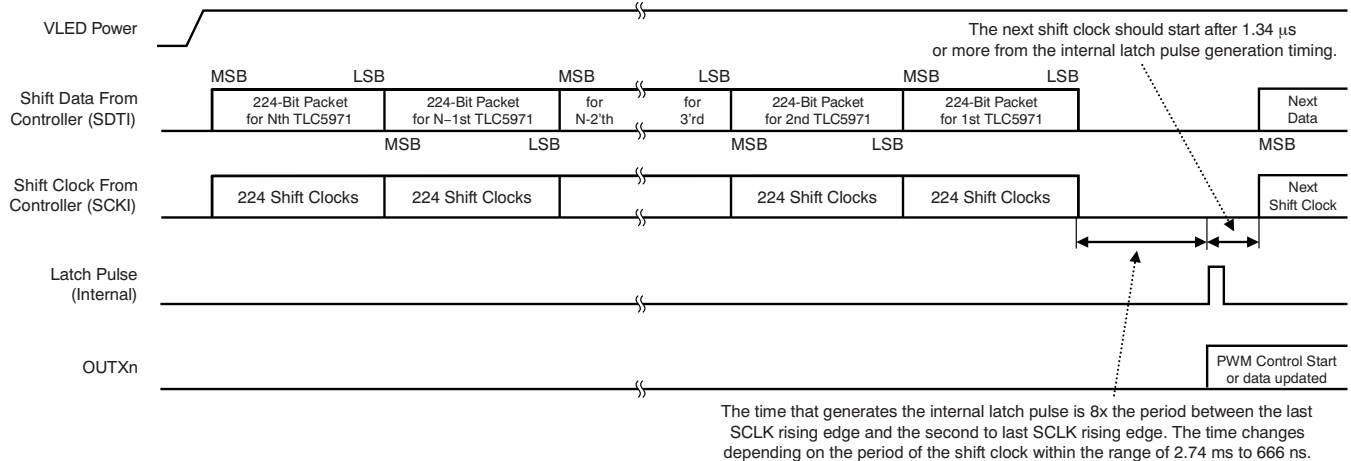

**Figure 32. Cascading Connection of  $N$  TLC5971 Units**

### Data Write and PWM Control with Internal Grayscale Clock Mode

When the EXTCLK bit is '0', the internal oscillator clock is used for PWM control of OUTXn ( $X = R/G/B$  and  $n = 0-3$ ) as the GS reference clock. This mode is ideal for illumination applications that change the display image at low frequencies. The data and clock timing is shown in Figure 9 and Figure 33. A writing procedure for the function setting and display control follows:

1. Power up VCC (VLED); all OUTXn are off because BLANK is set to '1'.
2. Write the 224-bit data packet (with MSB bit first) for the Nth TLC5971 using the SDTI and SCKI signals. The first six bits of the 224-bit data packet are used as the write command. The write command must be 25h (100101b); otherwise, the 218-bit data in the 224-bit shift register are not copied to the 218-bit data latch. The EXTCLK bit must be set to '0' for the internal oscillator mode. Also, the DSPRPT bit should be set to '1' to repeat the PWM timing control and BLANK set to '0' to start the PWM control.
3. Write the 224-bit data packet for the ( $N - 1$ ) TLC5971 without delay after step 2.
4. Repeat the data write sequence until all TLC5971s have data. The total shift clock count (SCKI) is now  $224 \times N$ . After all device data are written, stop the SCKI at a high or low level for  $8 \times$  the period between the last SCKI rising edge and the second to last SCKI rising edge. Then the 218 LSBs in the 224-bit shift register are copied to the 218-bit data latch in all devices and the PWM control is started or updated at the same time.

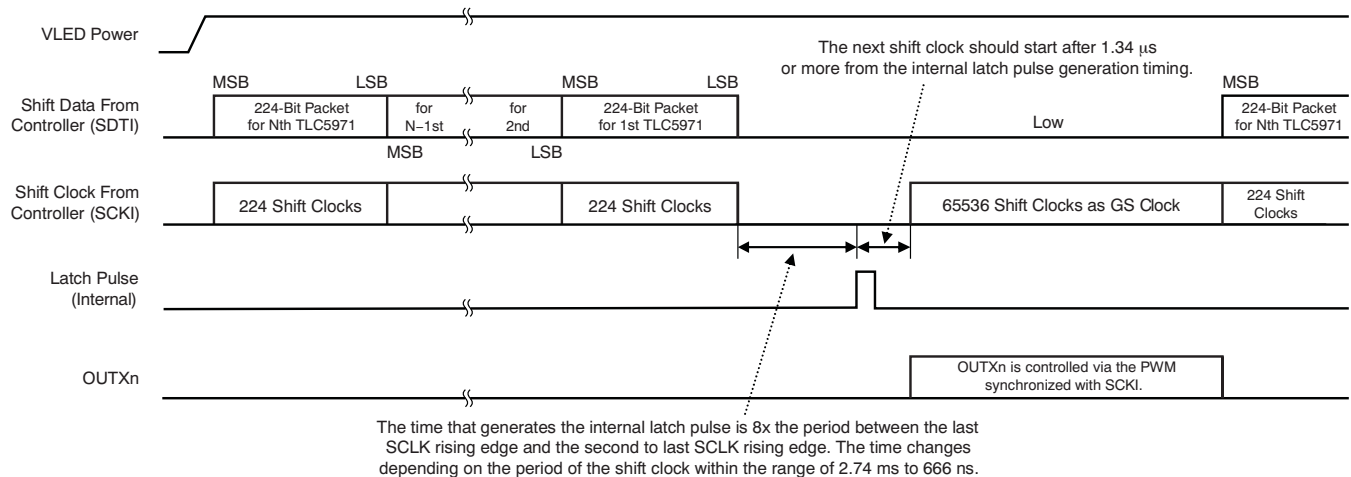

**Figure 33. Data Packet and Display Start/Update Timing 1 (Internal Oscillator Mode)**

### Data Write and PWM Control with External Grayscale Clock Mode

When the EXTCLK bit is '1', the data shift clock (SCKI) is used for PWM control of OUTX<sub>n</sub> (X = R/G/B and n = 0-3) as the GS reference clock. This mode is ideal for video image applications that change the display image with high frequencies or for certain display applications that must synchronize all TLC5971s. The data and clock timing are shown in Figure 9 and Figure 34. A writing procedure for the display data and display timing control follows:

1. Power- up VCC (VLED); all OUTX<sub>n</sub> are off because BLANK is set to '1'.
2. Write the 224-bit data packet MSB-first for the Nth TLC5971 using the SDTI and SCKI signals. The first six bits of the 224-bit data packet are used as the write command. The write command must be 25h (100101b); otherwise, the 218-bit data in the 224-bit shift register are not copied to the 218-bit data latch. The EXTCLK bit must be set to '1' for the external oscillator mode. Also, the DSPRPT bit should be set to '0' so that the PWM control is not repeated, the TMGRST bit should be set to '1' to reset the PWM control timing at the internal latch pulse generation, and BLANK must be set to '0' to start the PWM control.
3. Write the 224-bit data for the (N – 1) TLC5971 without delay after step 2.
4. Repeat the data write sequence until all TLC5971s have data. The total shift clock count (SCKI) is 224 × N. After all device data are written, stop the SCKI at a high or low level for 8× the period between the last SCKI rising edge and the second to last SCKI rising edge. Then the 218 LSBs in the 224-bit shift register are copied to the 218-bit data latch in all devices.
5. To start the PWM control, send one pulse of the SCKI clock with SDTI low after 1.34μs or more from step 4. The OUTX<sub>n</sub> are turned on when the output GS data are not 0000h.
6. Send the remaining 65535 SCKI clocks with SDTI low. Then the PWM control for OUTX<sub>n</sub> is synchronized with the SCKI clock and one display period is finished with a total of 65536 SCKI clock periods.
7. Repeat step 2 to step 6 for the next display period.



**Figure 34. Data Packet and Display Start/Update Timing 2 (External Clock Mode)**

There is another control procedure that is recommended for a long chain of cascaded devices. The data and clock timings are shown in [Figure 9](#) and [Figure 35](#). When 256 TLC5971 units are cascaded, use the following procedure:

1. Power up VCC (VLED); all OUTXn are off because BLANK is set to '1'.
2. Write the 224-bit data packet MSB-first for the 256th TLC5971 using the SDTI and SCKI signals. The EXTCLK bit must be set to '1' for the external oscillator mode. Also, the DSPRPT bit should be set to '0' so that the PWM control does not repeat, the TMGRST bit should be set to '1' to reset the PWM control timing with the internal latch pulse, and BLANK must be set to '0' to start the PWM control.
3. Repeat the data write sequence for all TLC5971s. The total shift clock count (SCKI) is 57344 ( $224 \times 256$ ). After all device data are written, stop the SCKI signal at a high or low level for eight or more periods between the last SCKI rising edge and the second to last SCKI rising edge. Then the 218 LSBs in the 224-bit shift register are copied to the 218-bit data latch in all devices.
4. To control the PWM, send 8192 SCKI clock periods with SDTI low after 1.34 $\mu$ s or more from step 3 (or step 7). These 8192 clock periods are used for the OUTXn PWM control.
5. Write the new 224-bit data packets to the 256th to first TLC5971s for the next display with  $256 \times 224$  SCKI clock for a total of 57344 clocks. The PWM control for OUTXn remains synchronized with the SCKI clock and one display period is finished with a total of 65536 SCKI clocks. The SCKI clock signal is therefore used for PWM control and, at the same time, to write data into the shift registers of all cascaded parts.
6. Stop the SCKI signal at a high or low level for eight or more periods between the last SCKI rising edge and the second to last SCKI rising edge. Then the 218-bit LSBs in the 224-bit shift register are copied to the 218-bit data latch in all devices.
7. Repeat step 4 to step 6 for the next display periods.

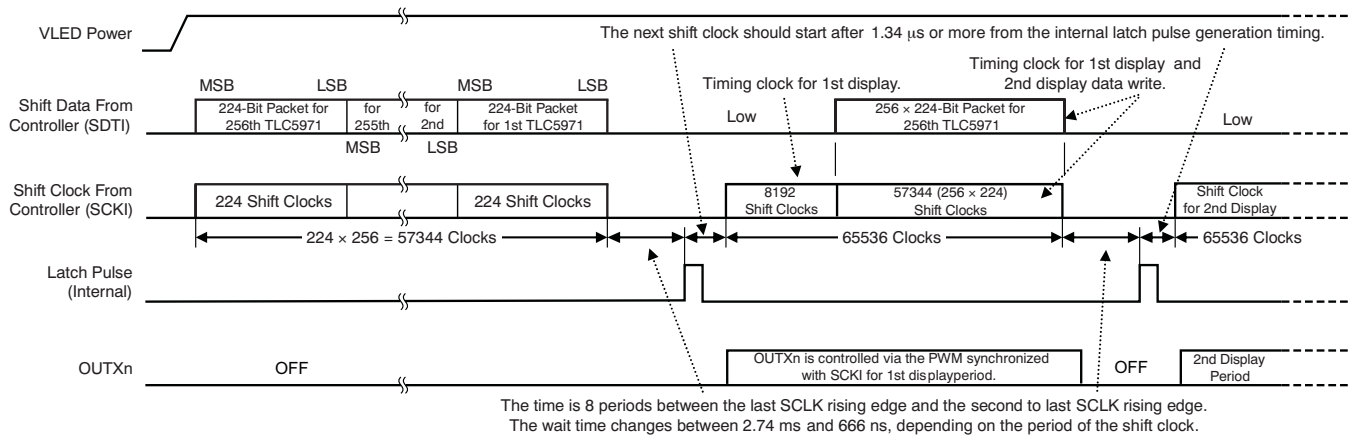

**Figure 35. Data Packet and Display Start/Update Timing 3 (External Clock Mode with 256 Cascaded Devices)**

## THERMAL SHUTDOWN

The thermal shutdown (TSD) function turns off all IC constant-current outputs when the junction temperature ( $T_J$ ) exceeds the threshold ( $T_{TSD} = +165^\circ\text{C}$ , typ). When the junction temperature drops below ( $T_{TSD} - T_{HYS}$ ), the output control starts at the first GS clock in the next display period.

## NOISE REDUCTION

Large surge currents may flow through the IC and the board if all 12 outputs turn on simultaneously at the start of each GS cycle. These large current surges could induce detrimental noise and EMI into other circuits. The TLC5971 turns on the outputs for each color group independently with a 25 ns (typ) rise time. The output current sinks are grouped into three groups. The first group that is turned on/off are OUTR0-3; the second group that is turned on/off are OUTG0-3; and the third group is OUTB0-3. However, the state of each output is controlled by the selected GS clock; see the [Output Timing Select Function](#) section.

**PACKAGING INFORMATION**

Orderable Device	Status <sup>(1)</sup>	Package Type	Package Drawing	Pins	Package Qty	Eco Plan <sup>(2)</sup>	Lead/ Ball Finish	MSL Peak Temp <sup>(3)</sup>	Samples (Requires Login)
TLC5971PWPR	ACTIVE	HTSSOP	PWP	20	2000	Green (RoHS & no Sb/Br)	CU NIPDAU	Level-2-260C-1 YEAR	<a href="#">Request Free Samples</a>
TLC5971RGER	PREVIEW	VQFN	RGE	24		TBD	Call TI	Call TI	Samples Not Available
TLC5971RGET	PREVIEW	VQFN	RGE	24		TBD	Call TI	Call TI	Samples Not Available

<sup>(1)</sup> The marketing status values are defined as follows:

**ACTIVE:** Product device recommended for new designs.

**LIFEBUY:** TI has announced that the device will be discontinued, and a lifetime-buy period is in effect.

**NRND:** Not recommended for new designs. Device is in production to support existing customers, but TI does not recommend using this part in a new design.

**PREVIEW:** Device has been announced but is not in production. Samples may or may not be available.

**OBSOLETE:** TI has discontinued the production of the device.

<sup>(2)</sup> Eco Plan - The planned eco-friendly classification: Pb-Free (RoHS), Pb-Free (RoHS Exempt), or Green (RoHS & no Sb/Br) - please check <http://www.ti.com/productcontent> for the latest availability information and additional product content details.

**TBD:** The Pb-Free/Green conversion plan has not been defined.

**Pb-Free (RoHS):** TI's terms "Lead-Free" or "Pb-Free" mean semiconductor products that are compatible with the current RoHS requirements for all 6 substances, including the requirement that lead not exceed 0.1% by weight in homogeneous materials. Where designed to be soldered at high temperatures, TI Pb-Free products are suitable for use in specified lead-free processes.

**Pb-Free (RoHS Exempt):** This component has a RoHS exemption for either 1) lead-based flip-chip solder bumps used between the die and package, or 2) lead-based die adhesive used between the die and leadframe. The component is otherwise considered Pb-Free (RoHS compatible) as defined above.

**Green (RoHS & no Sb/Br):** TI defines "Green" to mean Pb-Free (RoHS compatible), and free of Bromine (Br) and Antimony (Sb) based flame retardants (Br or Sb do not exceed 0.1% by weight in homogeneous material)

<sup>(3)</sup> MSL, Peak Temp. -- The Moisture Sensitivity Level rating according to the JEDEC industry standard classifications, and peak solder temperature.

**Important Information and Disclaimer:** The information provided on this page represents TI's knowledge and belief as of the date that it is provided. TI bases its knowledge and belief on information provided by third parties, and makes no representation or warranty as to the accuracy of such information. Efforts are underway to better integrate information from third parties. TI has taken and continues to take reasonable steps to provide representative and accurate information but may not have conducted destructive testing or chemical analysis on incoming materials and chemicals. TI and TI suppliers consider certain information to be proprietary, and thus CAS numbers and other limited information may not be available for release.

In no event shall TI's liability arising out of such information exceed the total purchase price of the TI part(s) at issue in this document sold by TI to Customer on an annual basis.

## TAPE AND REEL INFORMATION



### QUADRANT ASSIGNMENTS FOR PIN 1 ORIENTATION IN TAPE



\*All dimensions are nominal

Device	Package Type	Package Drawing	Pins	SPQ	Reel Diameter (mm)	Reel Width W1 (mm)	A0 (mm)	B0 (mm)	K0 (mm)	P1 (mm)	W (mm)	Pin1 Quadrant
TLC5971PWPR	HTSSOP	PWP	20	2000	330.0	16.4	6.95	7.1	1.6	8.0	16.0	Q1

**TAPE AND REEL BOX DIMENSIONS**

\*All dimensions are nominal

Device	Package Type	Package Drawing	Pins	SPQ	Length (mm)	Width (mm)	Height (mm)
TLC5971PWPR	HTSSOP	PWP	20	2000	346.0	346.0	33.0



# MECHANICAL DATA

PWP (R-PDSO-G\*\*) 20 PIN SHOWN

PowerPAD™ PLASTIC SMALL-OUTLINE PACKAGE

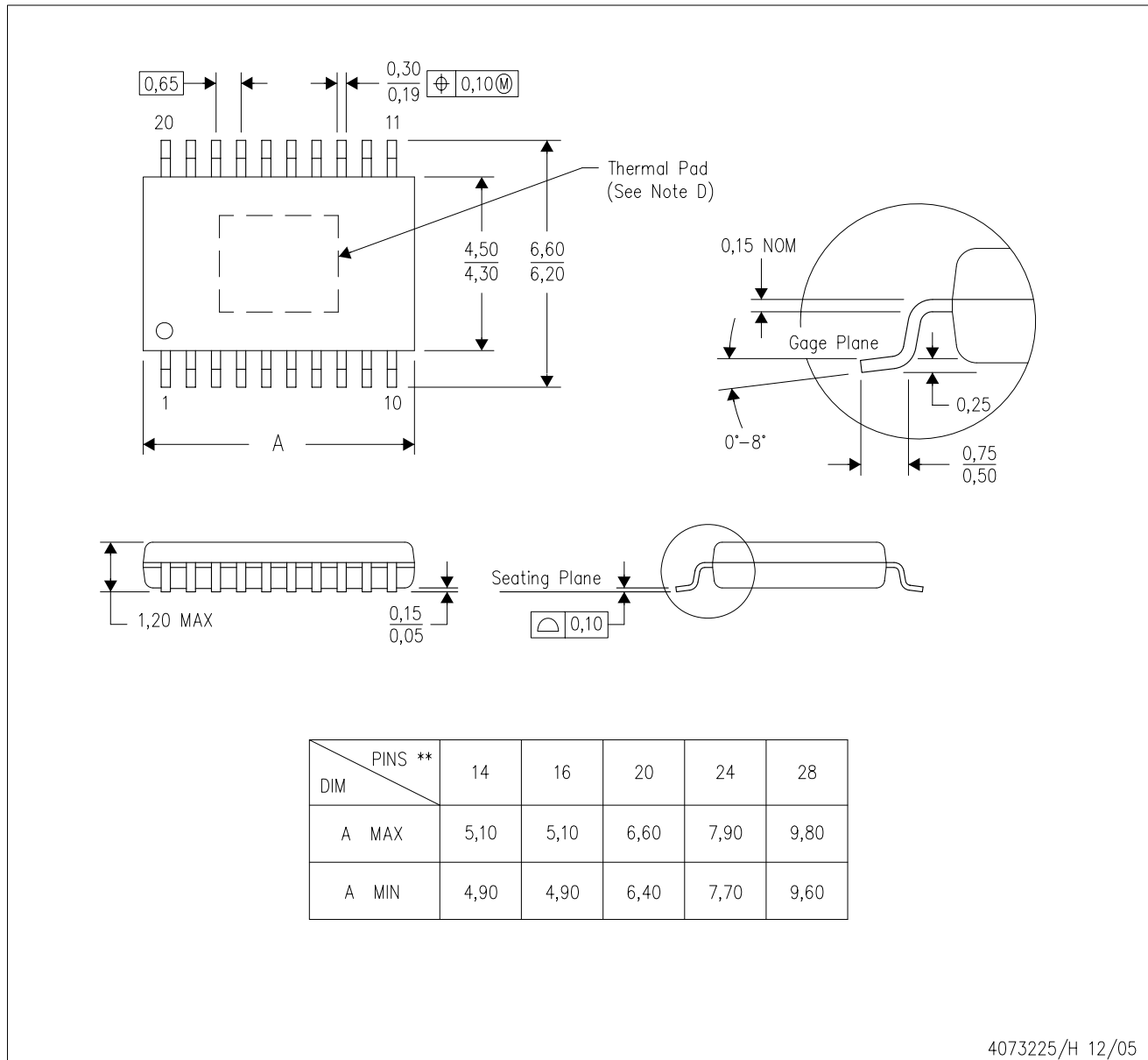

- NOTES:
- All linear dimensions are in millimeters.
  - This drawing is subject to change without notice.
  - Body dimensions do not include mold flash or protrusions. Mold flash and protrusion shall not exceed 0.15 per side.
  - This package is designed to be soldered to a thermal pad on the board. Refer to Technical Brief, PowerPad Thermally Enhanced Package, Texas Instruments Literature No. SLMA002 for information regarding recommended board layout. This document is available at [www.ti.com](http://www.ti.com) <<http://www.ti.com>>.
  - Falls within JEDEC MO-153

PowerPAD is a trademark of Texas Instruments.

# THERMAL PAD MECHANICAL DATA

PWP (R-PDSO-G20)

PowerPAD™ SMALL PLASTIC OUTLINE

## THERMAL INFORMATION

This PowerPAD™ package incorporates an exposed thermal pad that is designed to be attached to a printed circuit board (PCB). The thermal pad must be soldered directly to the PCB. After soldering, the PCB can be used as a heatsink. In addition, through the use of thermal vias, the thermal pad can be attached directly to the appropriate copper plane shown in the electrical schematic for the device, or alternatively, can be attached to a special heatsink structure designed into the PCB. This design optimizes the heat transfer from the integrated circuit (IC).

For additional information on the PowerPAD package and how to take advantage of its heat dissipating abilities, refer to Technical Brief, PowerPAD Thermally Enhanced Package, Texas Instruments Literature No. SLMA002 and Application Brief, PowerPAD Made Easy, Texas Instruments Literature No. SLMA004. Both documents are available at [www.ti.com](http://www.ti.com).

The exposed thermal pad dimensions for this package are shown in the following illustration.

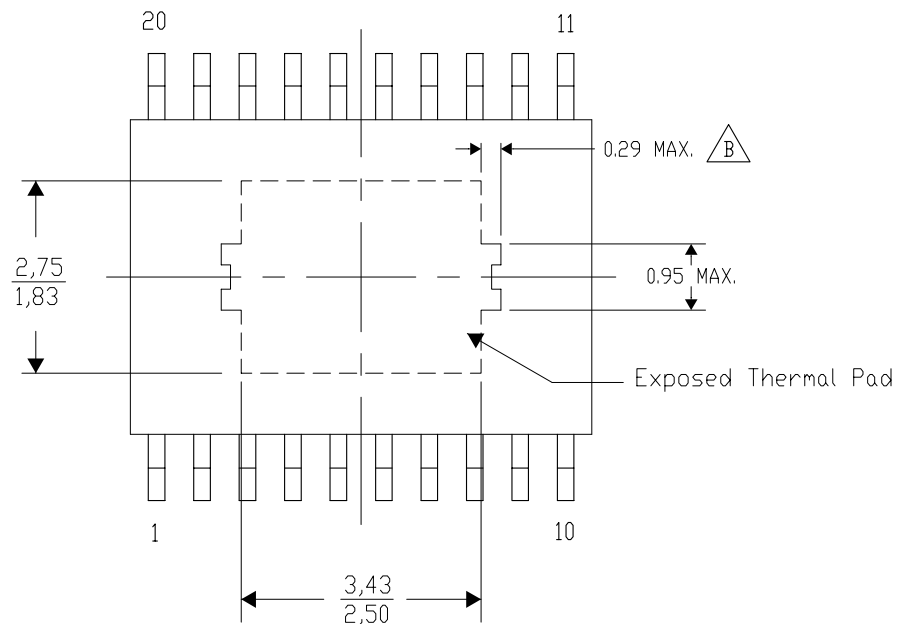

Top View

Exposed Thermal Pad Dimensions

4206332-10/R 08/10

NOTE: A. All linear dimensions are in millimeters

$\triangle B$ . Exposed tie strap features may not be present.

PWP (R-PDSO-G20)

PowerPAD™ PLASTIC SMALL OUTLINE

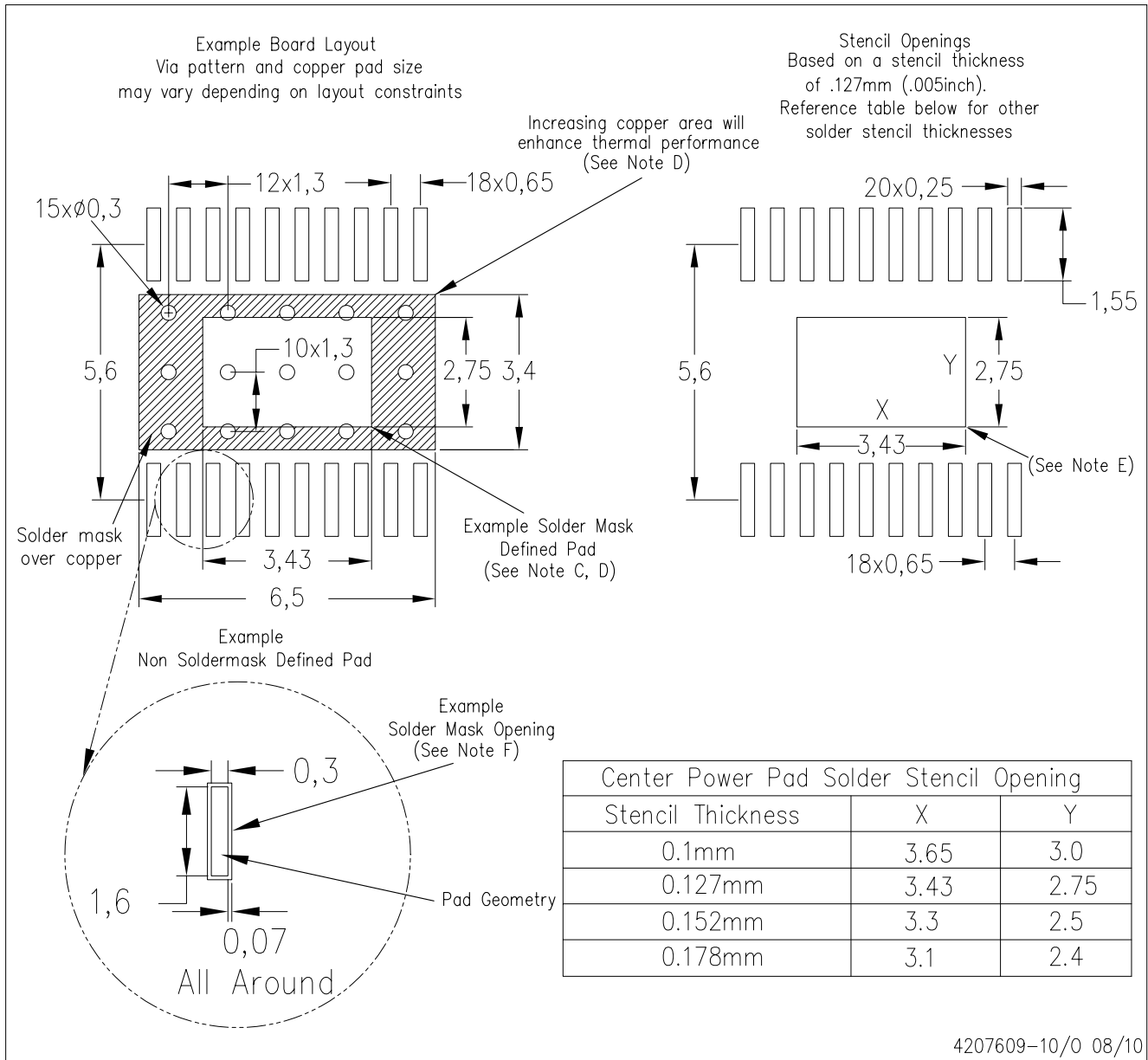

- NOTES:
- All linear dimensions are in millimeters.
  - This drawing is subject to change without notice.
  - Customers should place a note on the circuit board fabrication drawing not to alter the center solder mask defined pad.
  - This package is designed to be soldered to a thermal pad on the board. Refer to Technical Brief, PowerPad Thermally Enhanced Package, Texas Instruments Literature No. SLMA002, SLMA004, and also the Product Data Sheets for specific thermal information, via requirements, and recommended board layout. These documents are available at [www.ti.com](http://www.ti.com) <<http://www.ti.com>>. Publication IPC-7351 is recommended for alternate designs.
  - Laser cutting apertures with trapezoidal walls and also rounding corners will offer better paste release. Customers should contact their board assembly site for stencil design recommendations. Example stencil design based on a 50% volumetric metal load solder paste. Refer to IPC-7525 for other stencil recommendations.
  - Customers should contact their board fabrication site for solder mask tolerances between and around signal pads.

PowerPAD is a trademark of Texas Instruments.

RGE (S-PVQFN-N24)

PLASTIC QUAD FLATPACK NO-LEAD

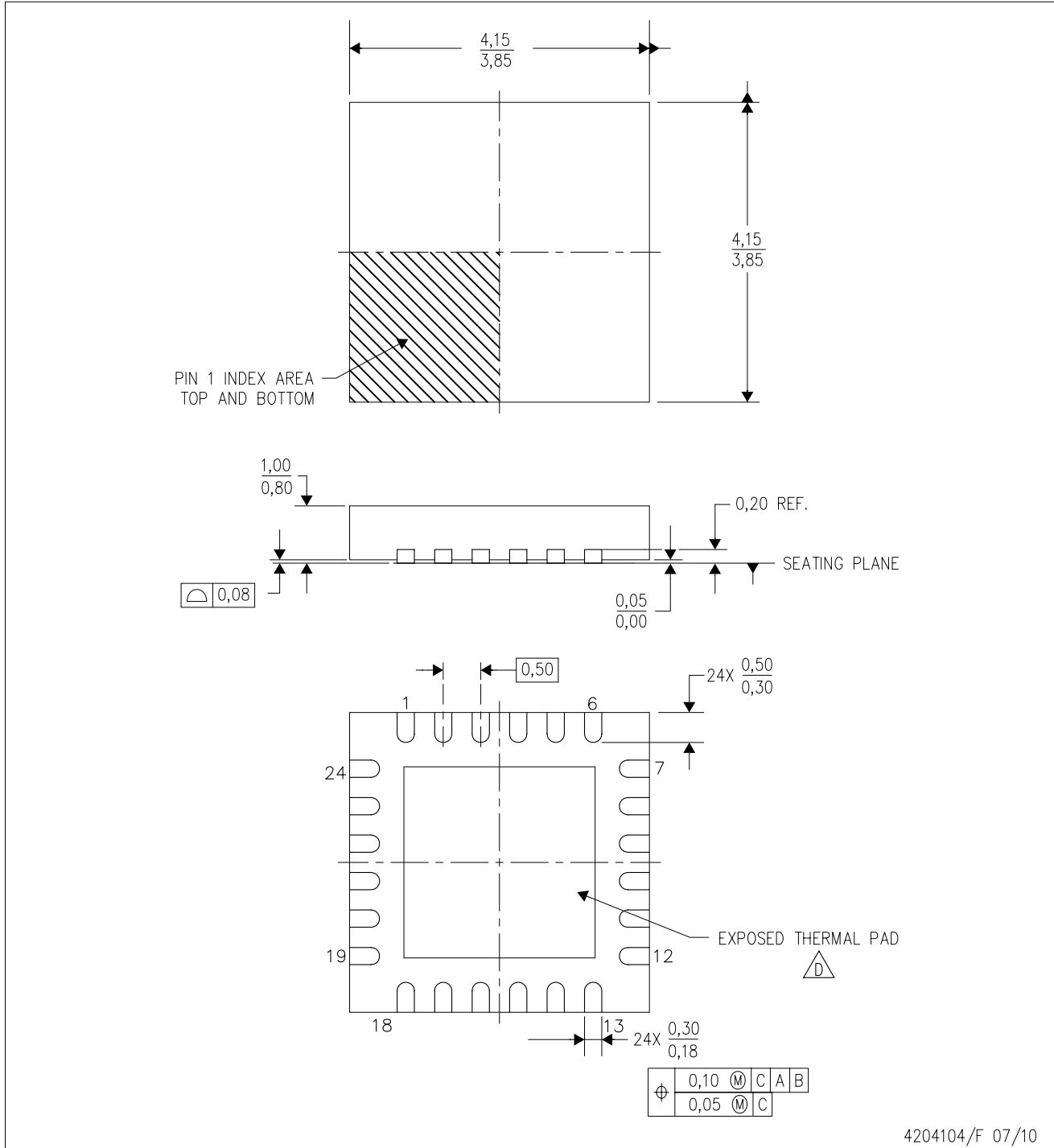

4204104/F 07/10

- NOTES:
- A. All linear dimensions are in millimeters. Dimensioning and tolerancing per ASME Y14.5M-1994.
  - B. This drawing is subject to change without notice.
  - C. Quad Flatpack, No-Leads (QFN) package configuration.
  - △ The package thermal pad must be soldered to the board for thermal and mechanical performance. See the Product Data Sheet for details regarding the exposed thermal pad dimensions.
  - E. Falls within JEDEC MO-220.

## IMPORTANT NOTICE

Texas Instruments Incorporated and its subsidiaries (TI) reserve the right to make corrections, modifications, enhancements, improvements, and other changes to its products and services at any time and to discontinue any product or service without notice. Customers should obtain the latest relevant information before placing orders and should verify that such information is current and complete. All products are sold subject to TI's terms and conditions of sale supplied at the time of order acknowledgment.

TI warrants performance of its hardware products to the specifications applicable at the time of sale in accordance with TI's standard warranty. Testing and other quality control techniques are used to the extent TI deems necessary to support this warranty. Except where mandated by government requirements, testing of all parameters of each product is not necessarily performed.

TI assumes no liability for applications assistance or customer product design. Customers are responsible for their products and applications using TI components. To minimize the risks associated with customer products and applications, customers should provide adequate design and operating safeguards.

TI does not warrant or represent that any license, either express or implied, is granted under any TI patent right, copyright, mask work right, or other TI intellectual property right relating to any combination, machine, or process in which TI products or services are used. Information published by TI regarding third-party products or services does not constitute a license from TI to use such products or services or a warranty or endorsement thereof. Use of such information may require a license from a third party under the patents or other intellectual property of the third party, or a license from TI under the patents or other intellectual property of TI.

Reproduction of TI information in TI data books or data sheets is permissible only if reproduction is without alteration and is accompanied by all associated warranties, conditions, limitations, and notices. Reproduction of this information with alteration is an unfair and deceptive business practice. TI is not responsible or liable for such altered documentation. Information of third parties may be subject to additional restrictions.

Resale of TI products or services with statements different from or beyond the parameters stated by TI for that product or service voids all express and any implied warranties for the associated TI product or service and is an unfair and deceptive business practice. TI is not responsible or liable for any such statements.

TI products are not authorized for use in safety-critical applications (such as life support) where a failure of the TI product would reasonably be expected to cause severe personal injury or death, unless officers of the parties have executed an agreement specifically governing such use. Buyers represent that they have all necessary expertise in the safety and regulatory ramifications of their applications, and acknowledge and agree that they are solely responsible for all legal, regulatory and safety-related requirements concerning their products and any use of TI products in such safety-critical applications, notwithstanding any applications-related information or support that may be provided by TI. Further, Buyers must fully indemnify TI and its representatives against any damages arising out of the use of TI products in such safety-critical applications.

TI products are neither designed nor intended for use in military/aerospace applications or environments unless the TI products are specifically designated by TI as military-grade or "enhanced plastic." Only products designated by TI as military-grade meet military specifications. Buyers acknowledge and agree that any such use of TI products which TI has not designated as military-grade is solely at the Buyer's risk, and that they are solely responsible for compliance with all legal and regulatory requirements in connection with such use.

TI products are neither designed nor intended for use in automotive applications or environments unless the specific TI products are designated by TI as compliant with ISO/TS 16949 requirements. Buyers acknowledge and agree that, if they use any non-designated products in automotive applications, TI will not be responsible for any failure to meet such requirements.

Following are URLs where you can obtain information on other Texas Instruments products and application solutions:

<b>Products</b>		<b>Applications</b>	
Amplifiers	<a href="http://amplifier.ti.com">amplifier.ti.com</a>	Audio	<a href="http://www.ti.com/audio">www.ti.com/audio</a>
Data Converters	<a href="http://dataconverter.ti.com">dataconverter.ti.com</a>	Automotive	<a href="http://www.ti.com/automotive">www.ti.com/automotive</a>
DLP® Products	<a href="http://www.dlp.com">www.dlp.com</a>	Communications and Telecom	<a href="http://www.ti.com/communications">www.ti.com/communications</a>
DSP	<a href="http://dsp.ti.com">dsp.ti.com</a>	Computers and Peripherals	<a href="http://www.ti.com/computers">www.ti.com/computers</a>
Clocks and Timers	<a href="http://www.ti.com/clocks">www.ti.com/clocks</a>	Consumer Electronics	<a href="http://www.ti.com/consumer-apps">www.ti.com/consumer-apps</a>
Interface	<a href="http://interface.ti.com">interface.ti.com</a>	Energy	<a href="http://www.ti.com/energy">www.ti.com/energy</a>
Logic	<a href="http://logic.ti.com">logic.ti.com</a>	Industrial	<a href="http://www.ti.com/industrial">www.ti.com/industrial</a>
Power Mgmt	<a href="http://power.ti.com">power.ti.com</a>	Medical	<a href="http://www.ti.com/medical">www.ti.com/medical</a>
Microcontrollers	<a href="http://microcontroller.ti.com">microcontroller.ti.com</a>	Security	<a href="http://www.ti.com/security">www.ti.com/security</a>
RFID	<a href="http://www.ti-rfid.com">www.ti-rfid.com</a>	Space, Avionics & Defense	<a href="http://www.ti.com/space-avionics-defense">www.ti.com/space-avionics-defense</a>
RF/IF and ZigBee® Solutions	<a href="http://www.ti.com/lprf">www.ti.com/lprf</a>	Video and Imaging	<a href="http://www.ti.com/video">www.ti.com/video</a>
		Wireless	<a href="http://www.ti.com/wireless-apps">www.ti.com/wireless-apps</a>

Mailing Address: Texas Instruments, Post Office Box 655303, Dallas, Texas 75265  
Copyright © 2010, Texas Instruments Incorporated