

16-Channel, Constant-Current LED Driver with 4-Channel Grouped Delay

 Check for Samples: [TLC59282](#)

FEATURES

- 16 Channels, Constant-Current Sink Output with On/Off Control
- Capability (Constant-Current Sink): 35 mA ($V_{CC} \leq 3.6$ V), 45 mA ($V_{CC} > 3.6$ V)
- LED Power-Supply Voltage up to 17 V
- $V_{CC} = 3$ V to 5.5 V
- Constant-Current Accuracy:
 - Channel-to-Channel = $\pm 0.6\%$ (typ), $\pm 2\%$ (max)
 - Device-to-Device = $\pm 1\%$ (typ), $\pm 3\%$ (max)
- Low Saturation Voltage: 0.31 V at 20 mA (typ)
 - $T_A = +25^\circ\text{C}$, One Channel On
- CMOS Logic Level I/O
- Data Transfer Rate: 35 MHz
- BLANK Pulse Width: 30 ns
- Four-Channel Grouped Delay for Noise Reduction
- Operating Temperature: -40°C to $+85^\circ\text{C}$

APPLICATIONS

- Video Displays
- Message Boards
- Illumination

DESCRIPTION

The TLC59282 is a 16-channel, constant-current sink driver. Each channel can be individually controlled via a simple serial communications protocol that is compatible with 3.3 V or 5 V CMOS logic levels, depending on the operating VCC. Once the serial data buffer is loaded, a rising edge on LATCH transfers the data to the LEDx outputs. The BLANK pin can be used to turn off all OUTn outputs during power-on and output data latching to prevent unwanted image displays during these times. The constant-current value of all 16 channels is set by a single external resistor. Multiple TLC59282s can be cascaded together to control additional LEDs from the same processor.

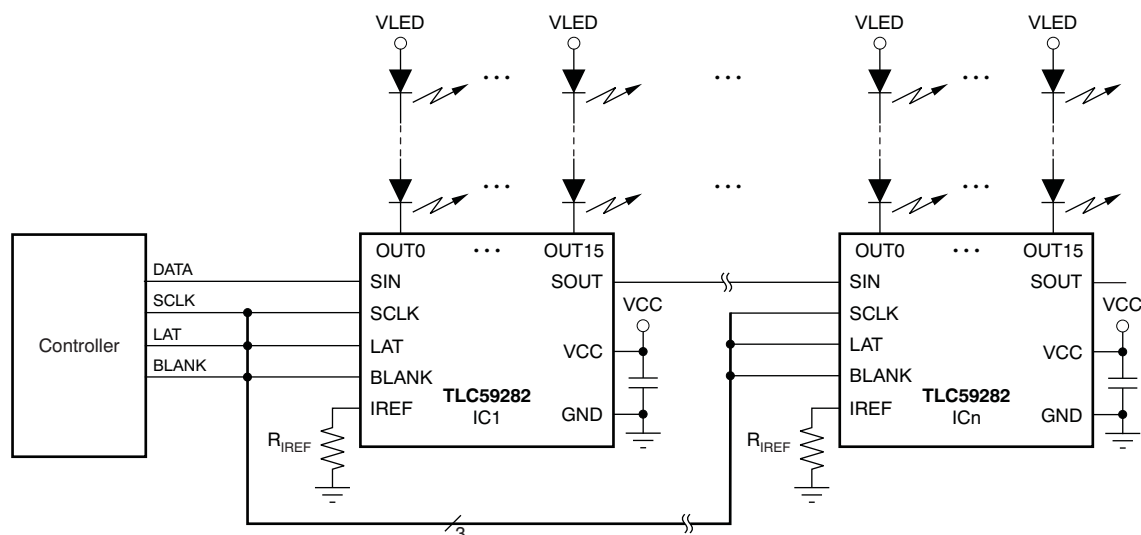

Typical Application Circuit (Multiple Daisy-Chainned TLC59282s)



Please be aware that an important notice concerning availability, standard warranty, and use in critical applications of Texas Instruments semiconductor products and disclaimers thereto appears at the end of this data sheet.

All trademarks are the property of their respective owners.



This integrated circuit can be damaged by ESD. Texas Instruments recommends that all integrated circuits be handled with appropriate precautions. Failure to observe proper handling and installation procedures can cause damage.

ESD damage can range from subtle performance degradation to complete device failure. Precision integrated circuits may be more susceptible to damage because very small parametric changes could cause the device not to meet its published specifications.

PACKAGE/ORDERING INFORMATION⁽¹⁾

PRODUCT	PACKAGE-LEAD	ORDERING NUMBER	TRANSPORT MEDIA, QUANTITY
TLC59282	SSOP-24/QSOP-24	TLC59282DBQR	Tape and Reel, 2500
		TLC59282DBQ	Tube, 50
TLC59282	QFN-24	TLC59282RGER	Tape and Reel, 3000
		TLC59282RGE	Tape and Reel, 250

(1) For the most current package and ordering information, see the Package Option Addendum at the end of this document, or visit the device product folder at www.ti.com.

ABSOLUTE MAXIMUM RATINGS⁽¹⁾⁽²⁾

Over operating free-air temperature range, unless otherwise noted.

PARAMETER		TLC59282	UNIT
V_{CC}	Supply voltage	-0.3 to +6	V
I_{OUT}	Output current (dc)	OUT0 to OUT15	50
V_{IN}	Input voltage range	SIN, SCLK, LAT, BLANK, IREF	-0.3 to $V_{CC} + 0.3$
V_{OUT}	Output voltage range	SOUT	-0.3 to $V_{CC} + 0.3$
		OUT0 to OUT15	-0.3 to +18
$T_{J(MAX)}$	Operating junction temperature	+150	°C
T_{STG}	Storage temperature range	-55 to +150	°C
ESD rating	Human body model (HBM)	4000	V
	Charged device model (CDM)	1000	V

- (1) Stresses above these ratings may cause permanent damage. Exposure to absolute maximum conditions for extended periods may degrade device reliability. These are stress ratings only, and functional operation of the device at these or any other conditions beyond those specified is not supported.
- (2) All voltage values are with respect to network ground terminal.

THERMAL INFORMATION

THERMAL METRIC ⁽¹⁾		TLC59282		UNITS
		DBQ	RGE	
		24 PINS	24 PINS	
θ_{JA}	Junction-to-ambient thermal resistance	73.2	46.8	°C/W
θ_{JCTop}	Junction-to-case (top) thermal resistance	44.6	48.6	
θ_{JB}	Junction-to-board thermal resistance	38.9	23.0	
Ψ_{JT}	Junction-to-top characterization parameter	12.3	1.2	
Ψ_{JB}	Junction-to-board characterization parameter	39.7	22.9	
θ_{JCbott}	Junction-to-case (bottom) thermal resistance	n/a	6.3	

(1) For more information about traditional and new thermal metrics, see the *IC Package Thermal Metrics* application report, [SPRA953](http://www.ti.com/lit/zip/SBPA953).

RECOMMENDED OPERATING CONDITIONS

 At $T_A = -40^\circ\text{C}$ to $+85^\circ\text{C}$, unless otherwise noted.

PARAMETER	TEST CONDITIONS	TLC59282			UNIT	
		MIN	NOM	MAX		
DC Characteristics: $V_{CC} = 3\text{ V to }5.5\text{ V}$						
V_{CC}	Supply voltage		3		5.5	V
V_O	Voltage applied to output		OUT0 to OUT15		17	V
V_{IH}	High-level input voltage		$0.7 \times V_{CC}$		V_{CC}	V
V_{IL}	Low-level input voltage		GND		$0.3 \times V_{CC}$	V
I_{OH}	High-level output current		SOUT		-1	mA
I_{OL}	Low-level output current		SOUT		1	mA
I_{OLC}	Constant output sink current		OUT0 to OUT15, $3\text{ V} \leq V_{CC} < 3.6\text{ V}$	2	35	mA
			OUT0 to OUT15, $3.6\text{ V} \leq V_{CC} < 5.5\text{ V}$	2	45	mA
T_A	Operating free-air temperature range		-40		+85	$^\circ\text{C}$
T_J	Operating junction temperature range		-40		+125	$^\circ\text{C}$
AC Characteristics: $V_{CC} = 3\text{ V to }5.5\text{ V}$						
f_{CLK} (SCLK)	Data shift clock frequency		SCLK		35	MHz
T_{WH0}	Pulse duration		SCLK	10		ns
T_{WL0}			SCLK	10		ns
T_{WH1}			LAT	20		ns
T_{WH2}			BLANK	60		ns
T_{WL2}			BLANK	30		ns
T_{SU0}		Setup time		SIN-SCLK \uparrow	4	
T_{SU1}			LAT \downarrow -SCLK \uparrow	10		ns
T_{H0}	Hold time		SIN-SCLK \uparrow	4		ns
T_{H1}			LAT \downarrow -SCLK \uparrow	10		ns

ELECTRICAL CHARACTERISTICS

At $V_{CC} = 3\text{ V}$ to 5.5 V and $T_A = -40^\circ\text{C}$ to $+85^\circ\text{C}$. Typical values at $V_{CC} = 3.3\text{ V}$ and $T_A = +25^\circ\text{C}$, unless otherwise noted.

PARAMETER		TEST CONDITIONS	TLC59282			UNIT
			MIN	TYP	MAX	
V_{OH}	High-level output voltage	$I_{OH} = -1\text{ mA}$ at SOUT	$V_{CC} - 0.4$		V_{CC}	V
V_{OL}	Low-level output voltage	$I_{OL} = 1\text{ mA}$ at SOUT			0.4	V
I_{IN}	Input current	$V_{IN} = V_{CC}$ or GND at SIN and SCLK	-1		1	μA
I_{CC0}	Supply current (V_{CC})	SIN/SCLK/LAT = low, BLANK = high, $V_{OUTn} = 1\text{ V}$, $R_{REF} = \text{open}$	0.1		1	mA
I_{CC1}		SIN/SCLK/LAT = low, BLANK = high, $V_{OUTn} = 1\text{ V}$, $R_{REF} = 3\text{ k}\Omega$ ($I_{OUT} = 16.8\text{ mA}$ target)	4.5		6	mA
I_{CC2}		All $OUTn = \text{ON}$, SIN/SCLK/LAT/BLANK = low, $V_{OUTn} = 1\text{ V}$, $R_{REF} = 3\text{ k}\Omega$	7		15	mA
I_{CC3}		All $OUTn = \text{ON}$, SIN/SCLK/LAT/BLANK = low, $V_{OUTn} = 1\text{ V}$, $R_{REF} = 1.5\text{ k}\Omega$ ($I_{OUT} = 33.6\text{ mA}$ target)	16		34	mA
I_{OLC}	Constant output current	All $OUTn = \text{ON}$, $V_{OUTn} = V_{OUTfix} = 1\text{ V}$, $R_{REF} = 1.5\text{ k}\Omega$ at OUT0 to OUT15 (see Figure 6), $T_A = +25^\circ\text{C}$	32.1	33.7	35.3	mA
I_{OLKG}	Output leakage current	$OUTn = \text{OFF}$, $V_{OUTn} = V_{OUTfix} = 17\text{ V}$, BLANK = high, $R_{REF} = 1.5\text{ k}\Omega$ at OUT0 to OUT15 (see Figure 6)			0.1	μA
ΔI_{OLC0}	Constant-current error (channel-to-channel) ⁽¹⁾	All $OUTn = \text{ON}$, $V_{OUTn} = V_{OUTfix} = 1\text{ V}$, $R_{REF} = 1.5\text{ k}\Omega$ at OUT0 to OUT15	± 0.6		± 2	%
ΔI_{OLC1}	Constant-current error (device-to-device) ⁽²⁾	All $OUTn = \text{ON}$, $V_{OUTn} = V_{OUTfix} = 1\text{ V}$, $R_{REF} = 1.5\text{ k}\Omega$ at OUT0 to OUT15, $T_A = +25^\circ\text{C}$	± 1		± 3	%
ΔI_{OLC2}	Line regulation ⁽³⁾	All $OUTn = \text{ON}$, $V_{OUTn} = V_{OUTfix} = 1\text{ V}$, $R_{REF} = 1.5\text{ k}\Omega$ at OUT0 to OUT15, $V_{CC} = 3\text{ V}$ to 5.5 V	± 0.5		± 1	%/V
ΔI_{OLC3}	Load regulation ⁽⁴⁾	All $OUTn = \text{ON}$, $V_{OUTn} = 1\text{ V}$ to 3 V , $V_{OUTfix} = 1\text{ V}$, $R_{REF} = 1.5\text{ k}\Omega$	± 1		± 3	%/V
V_{REF}	Reference voltage output	$R_{REF} = 1.5\text{ k}\Omega$, $T_A = +25^\circ\text{C}$	1.18	1.205	1.23	V
R_{PUP}	Pull-up resistor	BLANK	250	500	750	k Ω
R_{PDWN}	Pull-down resistor	LAT	250	500	750	k Ω

- (1) The deviation of each output from the average of OUT0–OUT15 constant-current. Deviation is calculated by the formula:

$$\Delta (\%) = \left[\frac{I_{OUTn}}{\frac{(I_{OUT0} + I_{OUT1} + \dots + I_{OUT14} + I_{OUT15})}{16}} - 1 \right] \times 100$$

- (2) The deviation of the OUT0–OUT15 constant-current average from the ideal constant-current value.

Deviation is calculated by the following formula:

$$\Delta (\%) = \left[\frac{\frac{(I_{OUT0} + I_{OUT1} + \dots + I_{OUT14} + I_{OUT15})}{16} - (\text{Ideal Output Current})}{\text{Ideal Output Current}} \right] \times 100$$

Ideal current is calculated by the formula:

$$I_{OUT(\text{IDEAL})} = 41.9 \times \left[\frac{1.205}{R_{REF}} \right]$$

- (3) Line regulation is calculated by this equation:

$$\Delta (\%/V) = \left[\frac{(I_{OUTn} \text{ at } V_{CC} = 5.5\text{ V}) - (I_{OUTn} \text{ at } V_{CC} = 3\text{ V})}{(I_{OUTn} \text{ at } V_{CC} = 3\text{ V})} \right] \times \frac{100}{5.5\text{ V} - 3\text{ V}}$$

- (4) Load regulation is calculated by the equation:

$$\Delta (\%/V) = \left[\frac{(I_{OUTn} \text{ at } V_{OUTn} = 3\text{ V}) - (I_{OUTn} \text{ at } V_{OUTn} = 1\text{ V})}{(I_{OUTn} \text{ at } V_{OUTn} = 1\text{ V})} \right] \times \frac{100}{3\text{ V} - 1\text{ V}}$$

SWITCHING CHARACTERISTICS

At $V_{CC} = 3\text{ V to }5.5\text{ V}$, $T_A = -40^\circ\text{C to }+85^\circ\text{C}$, $C_L = 15\text{ pF}$, $R_L = 130\ \Omega$, $R_{IREF} = 1.5\text{ k}\Omega$, and $V_{LED} = 5.5\text{ V}$. Typical values at $V_{CC} = 3.3\text{ V}$ and $T_A = +25^\circ\text{C}$, unless otherwise noted.

PARAMETER	TEST CONDITIONS	TLC59282			UNIT	
		MIN	TYP	MAX		
t_{R0}	Rise time	SOUT (see Figure 5)		5	12	ns
t_{R1}		OUTn (see Figure 4)		10	30	ns
t_{F0}	Fall time	SOUT (see Figure 5)		5	12	ns
t_{F1}		OUTn (see Figure 4)		10	30	ns
t_{D0}	Propagation delay time	SCLK \uparrow to SOUT $\uparrow\downarrow$		8	20	ns
t_{D1}		LAT \uparrow or BLANK $\uparrow\downarrow$ to OUT0/OUT7/OUT8/OUT15 on/off		18	36	ns
t_{D2}		LAT \uparrow or BLANK $\uparrow\downarrow$ to OUT1/OUT6/OUT9/OUT14 on/off		38	69	ns
t_{D3}		LAT \uparrow or BLANK $\uparrow\downarrow$ to OUT2/OUT5/OUT10/OUT13 on/off		58	102	ns
t_{D4}		LAT \uparrow or BLANK $\uparrow\downarrow$ to OUT3/OUT4/OUT11/OUT12 on/off		78	135	ns
t_{ON_ERR}	Output on-time error ⁽¹⁾	On/off latch data = all '1', 30 ns BLANK low level one-shot pulse input		-15	15	ns

(1) Output on-time error (t_{ON_ERR}) is calculated by the formula: $t_{ON_ERR}\text{ (ns)} = t_{OUT_ON} - \text{BLANK low level one-shot pulse width (}T_{WL2}\text{)}$. t_{OUT_ON} indicates the actual on-time of the constant-current output.

FUNCTIONAL BLOCK DIAGRAM

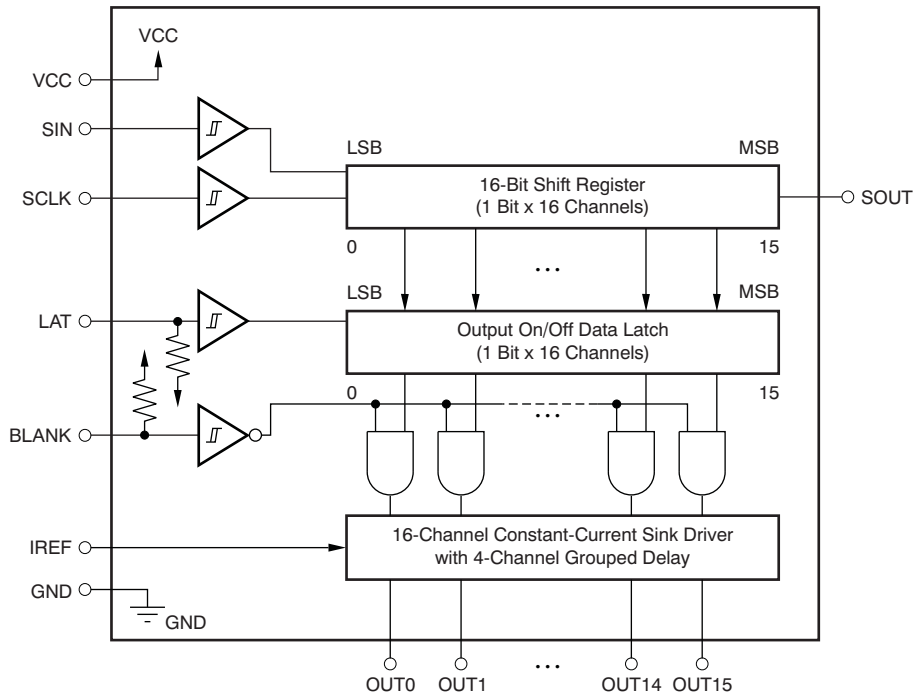

DEVICE INFORMATION

SSOP-24/QSOP-24
DBQ PACKAGE
(TOP VIEW)

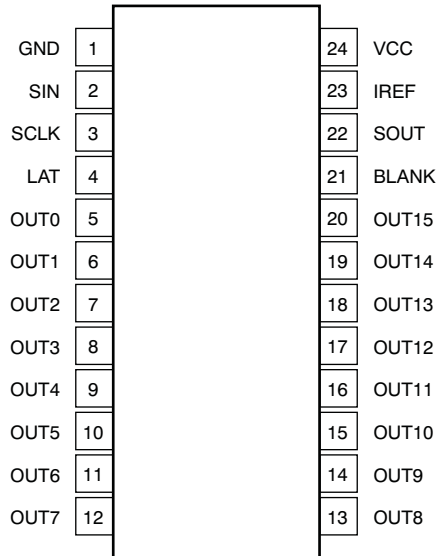

QFN-24
RGE PACKAGE
(TOP VIEW)

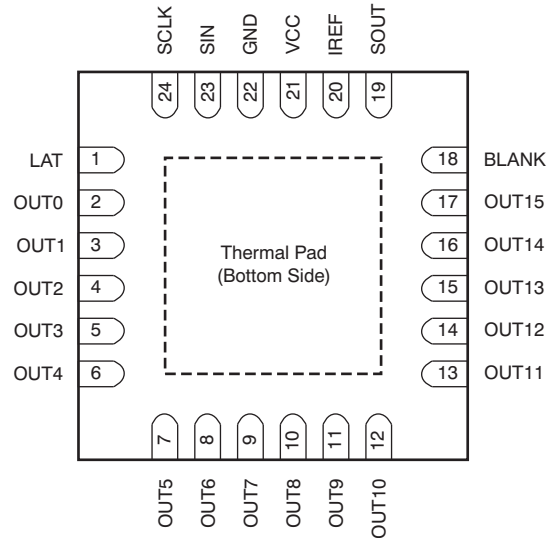

NOTE: Thermal pad is not connected to GND internally. The thermal pad must be connected to GND via the PCB pattern.

TERMINAL FUNCTIONS

TERMINAL			I/O	DESCRIPTION
NAME	DBQ	RGE		
SIN	2	23	I	Serial data input for driver on/off control; Schmitt buffer input. When SIN is high, data '1' are written into the LSB of the 16-bit shift register at the SCLK rising edge.
SCLK	3	24	I	Serial data shift clock; Schmitt buffer input. All data in the 16-bit shift register are shifted toward the MSB by 1-bit synchronization of SCLK.
LAT	4	1	I	Level triggered latch; Schmitt buffer input. The data in the 16-bit shift register continue to transfer to the output on/off data latch while LAT is high. Therefore, if the data in the 16-bit shift register are changed when LAT is high, the data in the data latch are also changed. The data in the data latch are held when LAT is low. This pin is internally pulled down to GND with a 500 k Ω (typ) resistor.
BLANK	21	18	I	Blank, all outputs; Schmitt buffer input. When BLANK is high, all constant-current outputs (OUT0–OUT15) are forced off. When BLANK is low, all constant-current outputs are controlled by the data in the output on/off data latch. This pin is internally pulled up to V _{CC} with a 500 k Ω (typ) resistor.
IREF	23	20	I/O	Constant-current value setting, OUT0–OUT15 sink constant-current is set to desired value by connection to an external resistor between IREF and GND.
SOUT	22	19	O	Serial data output. This output is connected to the MSB of the 16-bit shift register. SOUT data changes at the rising edge of SCLK.
OUT0	5	2	O	Constant-current output. Each output can be tied together with others to increase the constant-current. Different voltages can be applied to each output.
OUT1	6	3	O	Constant-current output
OUT2	7	4	O	Constant-current output
OUT3	8	5	O	Constant-current output
OUT4	9	6	O	Constant-current output
OUT5	10	7	O	Constant-current output
OUT6	11	8	O	Constant-current output
OUT7	12	9	O	Constant-current output
OUT8	13	10	O	Constant-current output
OUT9	14	11	O	Constant-current output
OUT10	15	12	O	Constant-current output
OUT11	16	13	O	Constant-current output
OUT12	17	14	O	Constant-current output
OUT13	18	15	O	Constant-current output
OUT14	19	16	O	Constant-current output
OUT15	20	17	O	Constant-current output
VCC	24	21	—	Power-supply voltage
GND	1	22	—	Power ground

PARAMETER MEASUREMENT INFORMATION

PIN EQUIVALENT INPUT AND OUTPUT SCHEMATIC DIAGRAMS

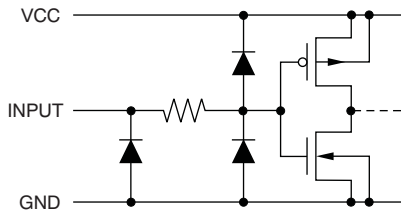

Figure 1. SIN, SCLK, LAT, BLANK

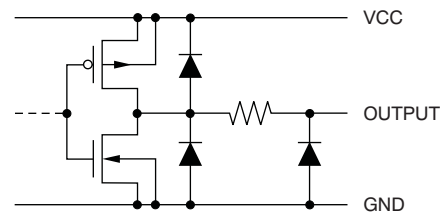

Figure 2. SOUT

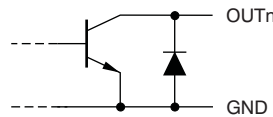
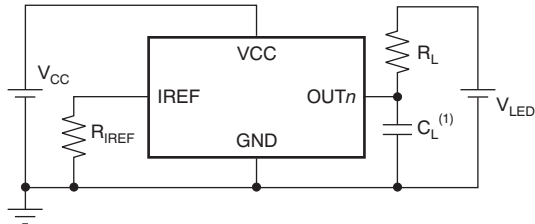

Figure 3. OUT0 Through OUT15

TEST CIRCUITS



(1) C_L includes measurement probe and jig capacitance.

Figure 4. Rise Time and Fall Time Test Circuit for OUTn

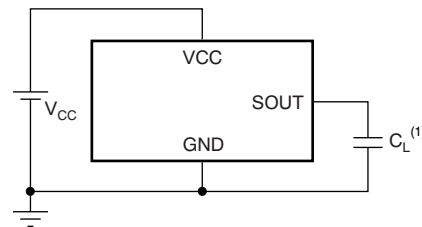

(1) C_L includes measurement probe and jig capacitance.

Figure 5. Rise Time and Fall Time Test Circuit for SOUT

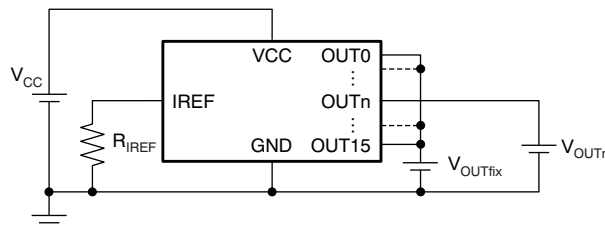
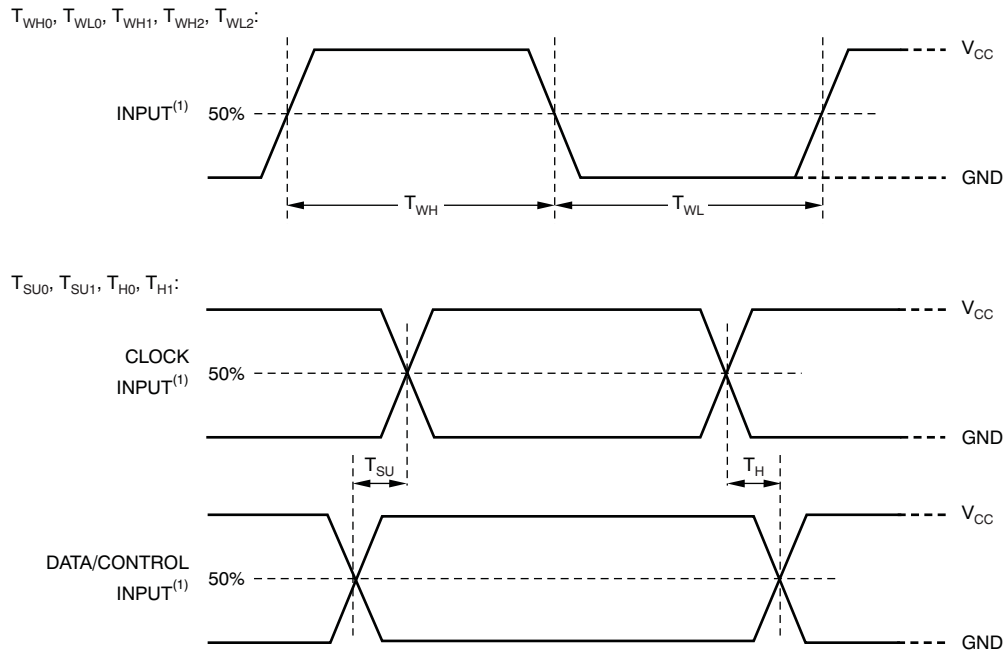

Figure 6. Constant-Current Test Circuit for OUTn

TIMING DIAGRAMS



(1) Input pulse rise and fall time is 1 ns to 3 ns.

Figure 7. Input Timing

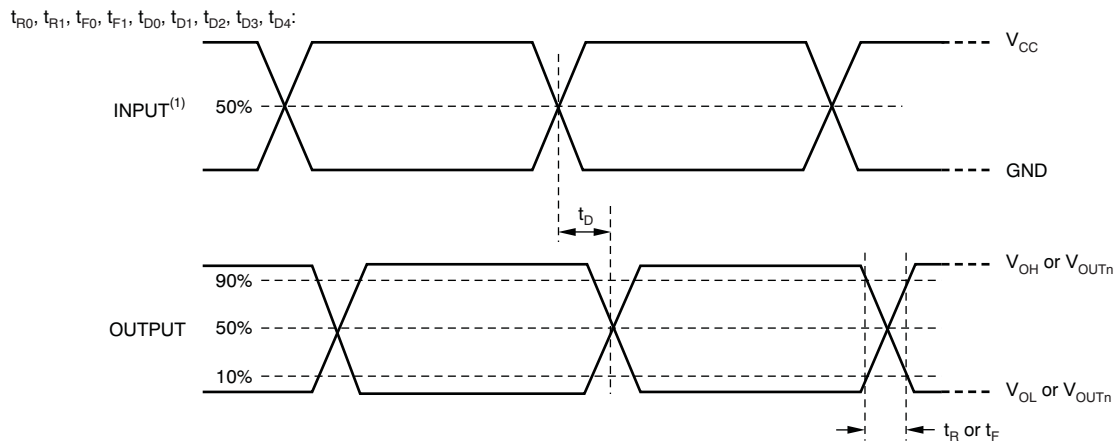

(1) Input pulse rise and fall time is 1 ns to 3 ns.

Figure 8. Output Timing

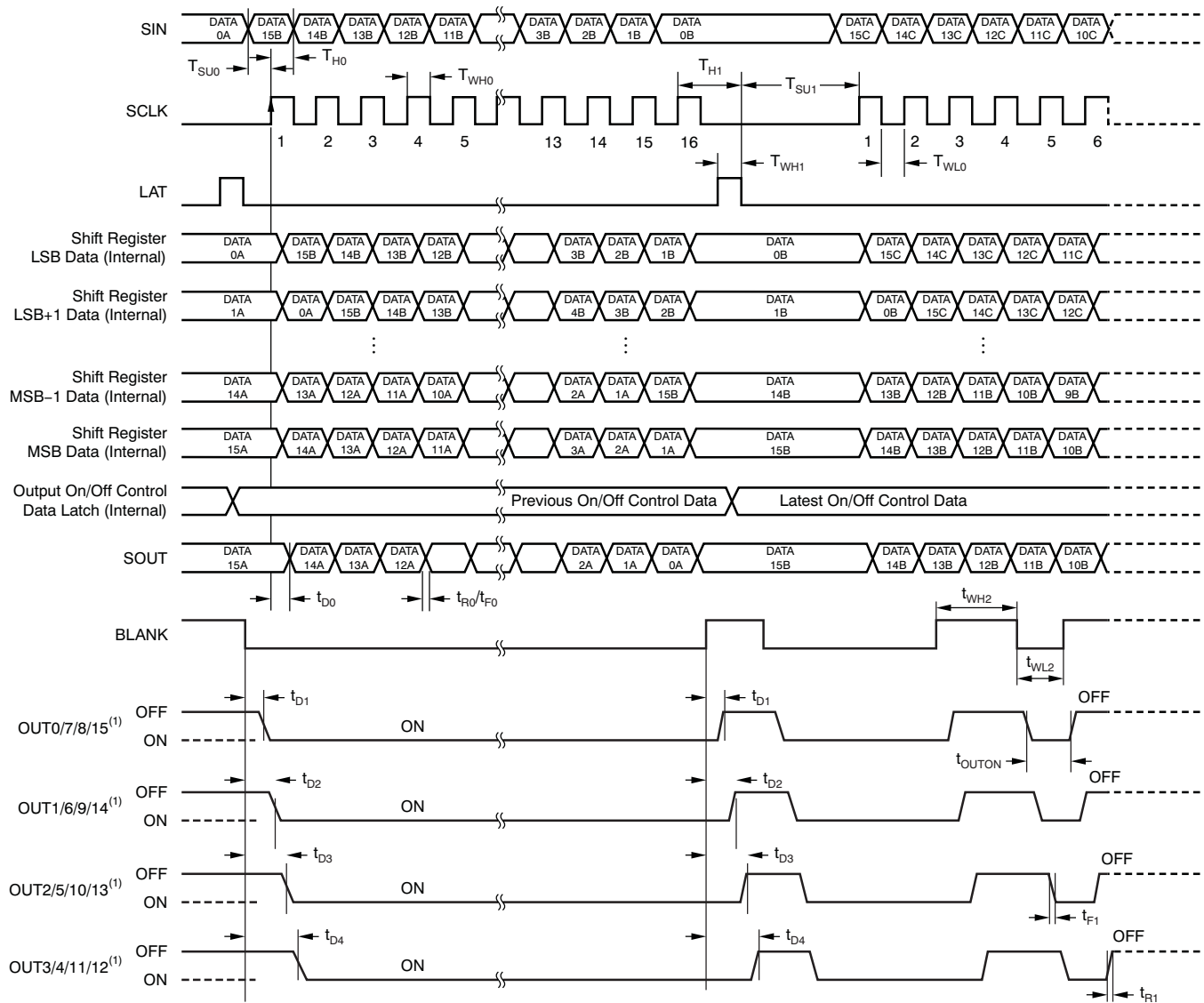

(1) Output on/off data = FFFFh.

(2) $t_{ON_ERR} = t_{OUTON} - T_{WL2}$.

Figure 9. Timing Diagram

TYPICAL CHARACTERISTICS

At $V_{CC} = 3.3\text{ V}$ and $T_A = +25^\circ\text{C}$, unless otherwise noted.

REFERENCE RESISTOR vs OUTPUT CURRENT

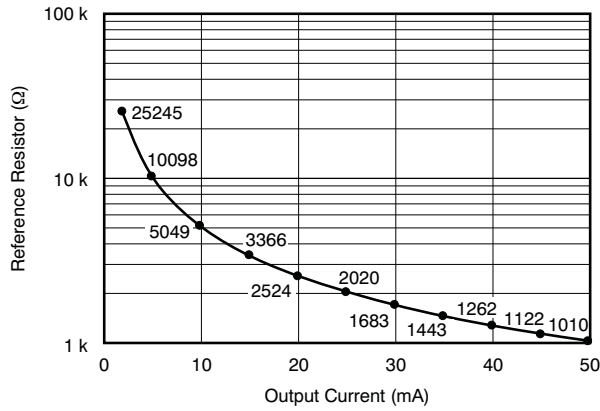

Figure 10.

OUTPUT CURRENT vs OUTPUT VOLTAGE

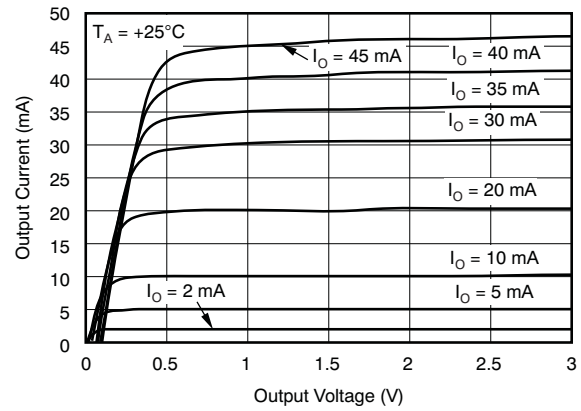

Figure 11.

OUTPUT CURRENT vs OUTPUT VOLTAGE

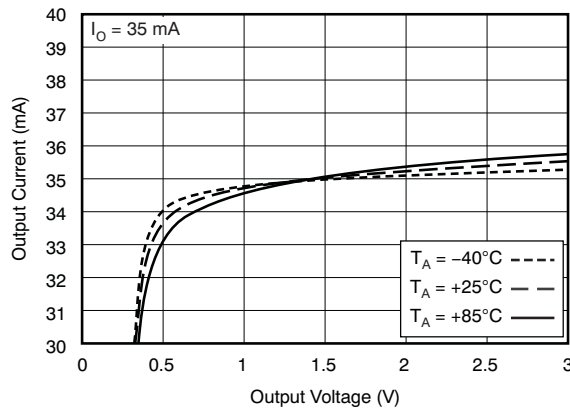

Figure 12.

ΔI_{OLC} vs AMBIENT TEMPERATURE

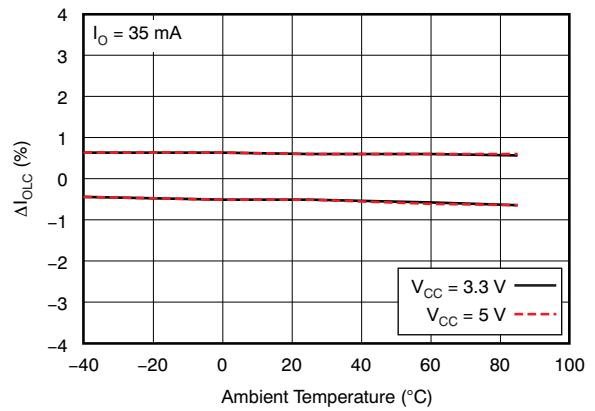

Figure 13.

ΔI_{OLC} vs OUTPUT CURRENT

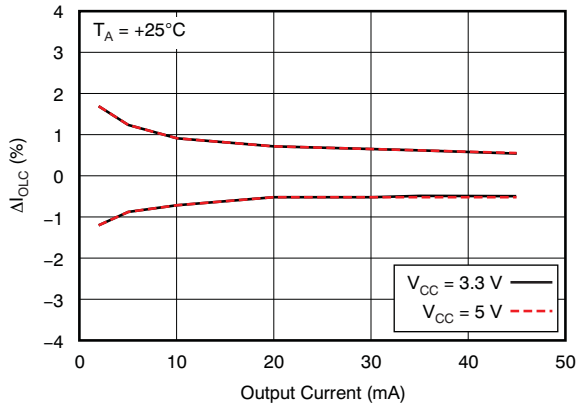

Figure 14.

CONSTANT-CURRENT OUTPUT VOLTAGE WAVEFORM

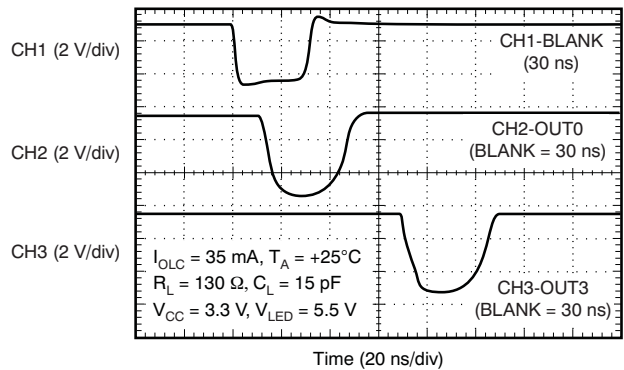

Figure 15.

DETAILED DESCRIPTION

SETTING FOR THE CONSTANT SINK CURRENT VALUE

The constant-current values are determined by an external resistor (R_{IREF}) placed between IREF and GND. The resistor (R_{IREF}) value is calculated by [Equation 1](#).

$$R_{IREF} \text{ (k}\Omega\text{)} = \frac{V_{IREF} \text{ (V)}}{I_{OLC} \text{ (mA)}} \times 41.9$$

Where:

$$V_{IREF} = \text{the internal reference voltage on the IREF pin (typically 1.205 V)} \quad (1)$$

I_{OLC} must be set in the range of 2 mA to 35 mA when V_{CC} is less than 3.6 V. Also, when V_{CC} is equal to 3.6 V or greater, I_{OLC} must be set in the range of 2 mA to 45 mA. The constant sink current characteristic for the external resistor value is shown in [Figure 10](#). [Table 1](#) describes the constant-current output versus external resistor value.

Table 1. Constant-Current Output versus External Resistor Value

I_{OLC} (mA, Typical)	R_{IREF} (k Ω)
45 ($V_{CC} > 3.6$ V only)	1.12
40 ($V_{CC} > 3.6$ V only)	1.26
35	1.44
30	1.68
25	2.02
20	2.52
15	3.37
10	5.05
5	10.1
2	25.2

CONSTANT-CURRENT DRIVER ON/OFF CONTROL

When BLANK is low, the corresponding output is turned on if the data in the on/off control data latch are '1' and remains off if the data are '0'. When BLANK is high, all outputs are forced off. This control is shown in [Table 2](#).

Table 2. On/Off Control Data Truth Table

OUTPUT ON/OFF DATA	CONSTANT-CURRENT OUTPUT STATUS
0	Off
1	On

When the IC is initially powered on, the data in the 16-bit shift register and output on/off data latch are not set to the respective default value. Therefore, the output on/off data must be written to the data latch before turning the constant-current output on. BLANK should be at a high level when powered on because the constant-current may be turned on as a result of random data in the output on/off data latch.

The output on/off data corresponding to any unconnected OUTn outputs should be set to '0' before turning on the remaining outputs. Otherwise, the supply current (I_{CC}) increases while the LEDs are on.

REGISTER CONFIGURATION

The TLC59282 has a 16-bit shift register and an output on/off data latch. Both the shift register and data latch are 16 bits long and are used to turn the constant-current outputs on and off. Figure 16 shows the shift register and data latch configuration. The data at the SIN pin are shifted in to the LSB of the 16-bit shift register at the rising edge of the SCLK pin; SOUT data change at the rising edge of SCLK.

The output on/off data in the 16-bit shift register continue to transfer to the output on/off data latch while LAT is high. Therefore, if the data in the 16-bit shift register are changed when LAT is high, the data in the data latch are also changed. The data in the data latch are held when LAT is low. When the IC initially powers on, the data in the output on/off shift register and latch are not set to the default values; on/off control data must be written to the on/off control data latch before turning the constant-current output on. BLANK should be high when the IC is powered on because the constant-current may be turned on at that time as a result of random values in the on/off data latch. All constant-current outputs are forced off when BLANK is high. The OUTn on/off are controlled by the data in the output on/off data latch. The timing diagram and truth table for writing data are shown in Figure 17 and Table 3.

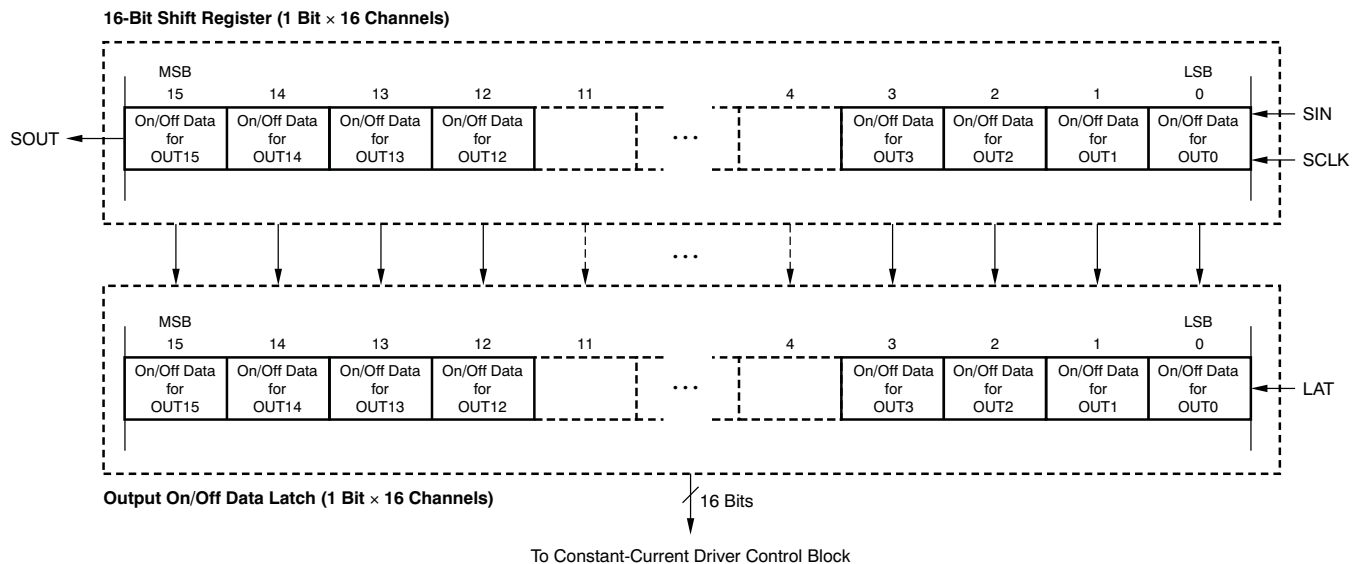

Figure 16. 16-Bit Shift Register and Output On/Off Data Latch Configuration

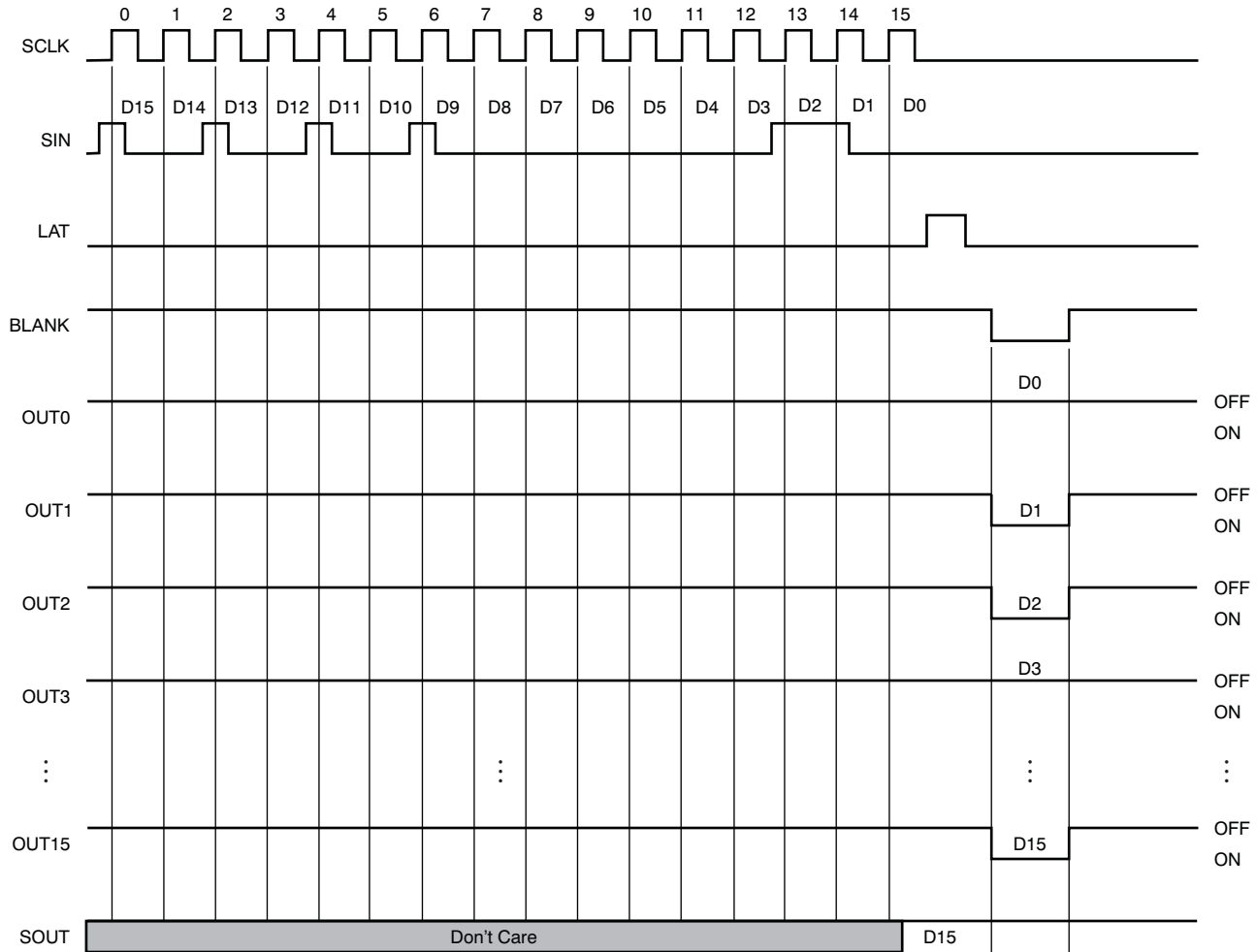

Figure 17. Operation Timing Diagram

Table 3. Truth Table in Operation

SCLK	LAT	BLANK	SIN	OUT0...OUT7...OUT15	SOUT
↑	High	Low	Dn	Dn...Dn – 7...Dn – 15	Dn – 15
↑	Low	Low	Dn + 1	No change	Dn – 14
↑	High	Low	Dn + 2	Dn + 2...Dn – 5...Dn – 13	Dn – 13
↓	—	Low	Dn + 3	Dn + 2...Dn – 5...Dn – 13	Dn – 13
↓	—	High	Dn + 3	Off	Dn – 13

NOISE REDUCTION

Large surge currents may flow through the IC and the board if all 16 outputs turn on or off simultaneously. These large current surges could induce detrimental noise and electromagnetic interference (EMI) into other circuits. The TLC59282 independently turns on or off the outputs for each color group with a 20 ns (typ) delay time; see Figure 9. The output current sinks are grouped into four groups. The first group that is turned on/off are OUT0/7/8/15; the second group that is turned on/off are OUT1/6/9/14; the third group that is turned on/off are OUT2/5/10/13; and the fourth group is OUT3/4/11/12. Both turn-on and turn-off are delayed. However, the state of each output is controlled by the data in the output on-off data latch and BLANK level.

REVISION HISTORY

NOTE: Page numbers for previous revisions may differ from page numbers in the current version.

Changes from Revision B (July 2011) to Revision C Page

- Added *Low Saturation Voltage* Features bullet 1
-

Changes from Revision A (December 2010) to Revision B Page

- Changed Constant-Current Accuracy Features bullet 1
 - Added RGE package information to *Package/Ordering Information* table 2
 - Added RGE package to *Thermal Information* table 2
 - Changed *Input current* parameter test conditions in Electrical Characteristics table 4
 - Added RGE pin out and footnote to *Device Information* section 6
 - Added RGE information to *Terminal Functions* table 7
 - Deleted Figure 11, *POWER DISSIPATION RATE vs FREE-AIR TEMPERATURE* 11
-

PACKAGING INFORMATION

Orderable Device	Status (1)	Package Type	Package Drawing	Pins	Package Qty	Eco Plan (2)	Lead/Ball Finish	MSL Peak Temp (3)	Op Temp (°C)	Top-Side Markings (4)	Samples
TLC59282DBQ	ACTIVE	SSOP	DBQ	24	50	Green (RoHS & no Sb/Br)	CU NIPDAU	Level-2-260C-1 YEAR	-40 to 85	TLC59282	Samples
TLC59282DBQR	ACTIVE	SSOP	DBQ	24	2500	Green (RoHS & no Sb/Br)	CU NIPDAU	Level-2-260C-1 YEAR	-40 to 85	TLC59282	Samples
TLC59282RGER	ACTIVE	VQFN	RGE	24	3000	Green (RoHS & no Sb/Br)	CU NIPDAU	Level-2-260C-1 YEAR	-40 to 85	TLC 59282	Samples
TLC59282RGET	ACTIVE	VQFN	RGE	24	250	Green (RoHS & no Sb/Br)	CU NIPDAU	Level-2-260C-1 YEAR	-40 to 85	TLC 59282	Samples

(1) The marketing status values are defined as follows:

ACTIVE: Product device recommended for new designs.

LIFEBUY: TI has announced that the device will be discontinued, and a lifetime-buy period is in effect.

NRND: Not recommended for new designs. Device is in production to support existing customers, but TI does not recommend using this part in a new design.

PREVIEW: Device has been announced but is not in production. Samples may or may not be available.

OBSELETE: TI has discontinued the production of the device.

(2) Eco Plan - The planned eco-friendly classification: Pb-Free (RoHS), Pb-Free (RoHS Exempt), or Green (RoHS & no Sb/Br) - please check <http://www.ti.com/productcontent> for the latest availability information and additional product content details.

TBD: The Pb-Free/Green conversion plan has not been defined.

Pb-Free (RoHS): TI's terms "Lead-Free" or "Pb-Free" mean semiconductor products that are compatible with the current RoHS requirements for all 6 substances, including the requirement that lead not exceed 0.1% by weight in homogeneous materials. Where designed to be soldered at high temperatures, TI Pb-Free products are suitable for use in specified lead-free processes.

Pb-Free (RoHS Exempt): This component has a RoHS exemption for either 1) lead-based flip-chip solder bumps used between the die and package, or 2) lead-based die adhesive used between the die and leadframe. The component is otherwise considered Pb-Free (RoHS compatible) as defined above.

Green (RoHS & no Sb/Br): TI defines "Green" to mean Pb-Free (RoHS compatible), and free of Bromine (Br) and Antimony (Sb) based flame retardants (Br or Sb do not exceed 0.1% by weight in homogeneous material)

(3) MSL, Peak Temp. -- The Moisture Sensitivity Level rating according to the JEDEC industry standard classifications, and peak solder temperature.

(4) Multiple Top-Side Markings will be inside parentheses. Only one Top-Side Marking contained in parentheses and separated by a "~" will appear on a device. If a line is indented then it is a continuation of the previous line and the two combined represent the entire Top-Side Marking for that device.

Important Information and Disclaimer: The information provided on this page represents TI's knowledge and belief as of the date that it is provided. TI bases its knowledge and belief on information provided by third parties, and makes no representation or warranty as to the accuracy of such information. Efforts are underway to better integrate information from third parties. TI has taken and continues to take reasonable steps to provide representative and accurate information but may not have conducted destructive testing or chemical analysis on incoming materials and chemicals. TI and TI suppliers consider certain information to be proprietary, and thus CAS numbers and other limited information may not be available for release.

In no event shall TI's liability arising out of such information exceed the total purchase price of the TI part(s) at issue in this document sold by TI to Customer on an annual basis.

TAPE AND REEL INFORMATION



QUADRANT ASSIGNMENTS FOR PIN 1 ORIENTATION IN TAPE



*All dimensions are nominal

Device	Package Type	Package Drawing	Pins	SPQ	Reel Diameter (mm)	Reel Width W1 (mm)	A0 (mm)	B0 (mm)	K0 (mm)	P1 (mm)	W (mm)	Pin1 Quadrant
TLC59282RGER	VQFN	RGE	24	3000	330.0	12.4	4.25	4.25	1.15	8.0	12.0	Q2
TLC59282RGET	VQFN	RGE	24	250	180.0	12.4	4.25	4.25	1.15	8.0	12.0	Q2

TAPE AND REEL BOX DIMENSIONS

*All dimensions are nominal

Device	Package Type	Package Drawing	Pins	SPQ	Length (mm)	Width (mm)	Height (mm)
TLC59282RGER	VQFN	RGE	24	3000	367.0	367.0	35.0
TLC59282RGET	VQFN	RGE	24	250	210.0	185.0	35.0

DBQ (R-PDSO-G24)

PLASTIC SMALL-OUTLINE PACKAGE

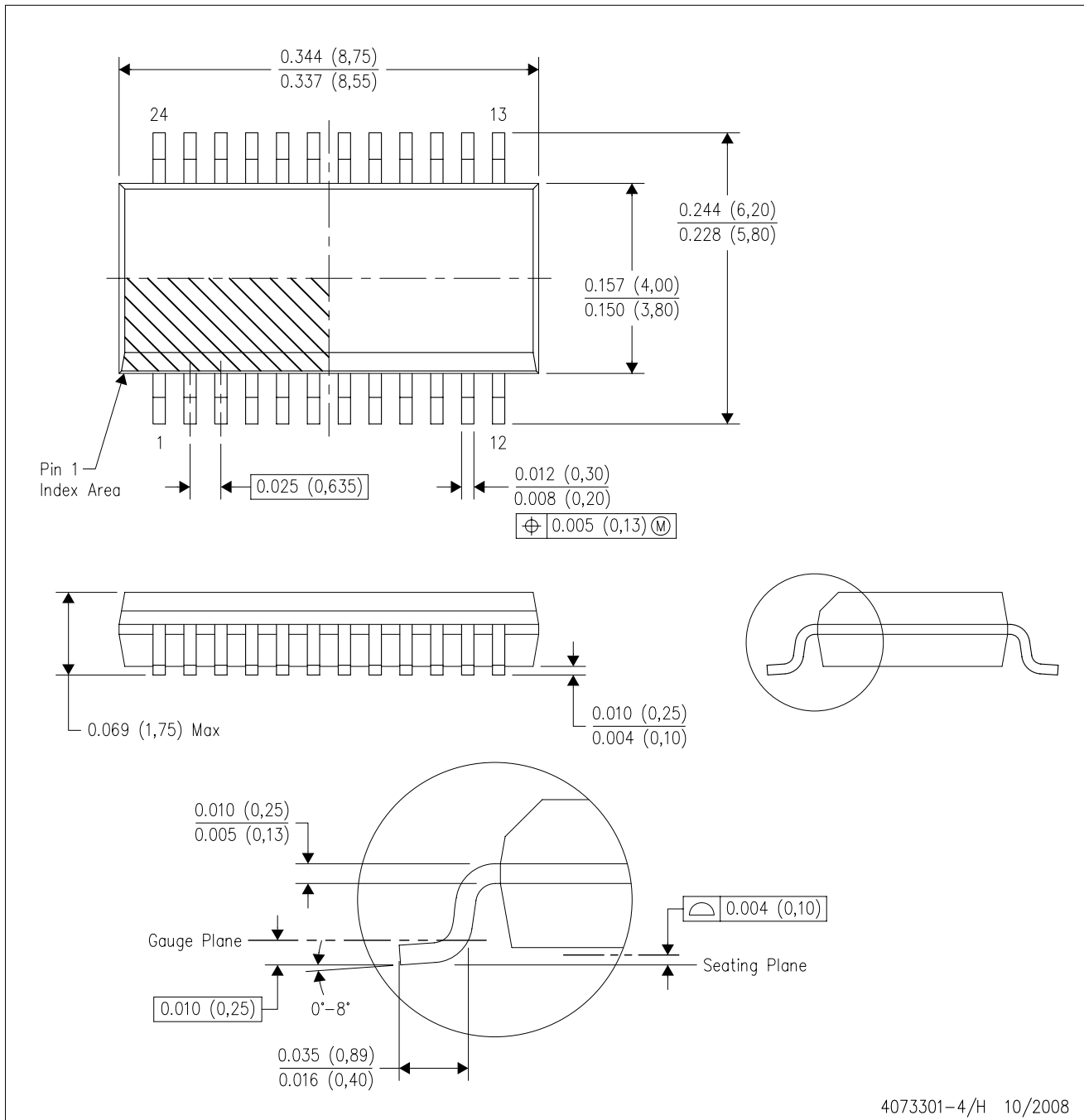

- NOTES:
- A. All linear dimensions are in inches (millimeters).
 - B. This drawing is subject to change without notice.
 - C. Body dimensions do not include mold flash or protrusion not to exceed 0.006 (0,15) per side.
 - D. Falls within JEDEC MO-137 variation AE.

DBQ (R-PDSO-G24)

PLASTIC SMALL OUTLINE PACKAGE

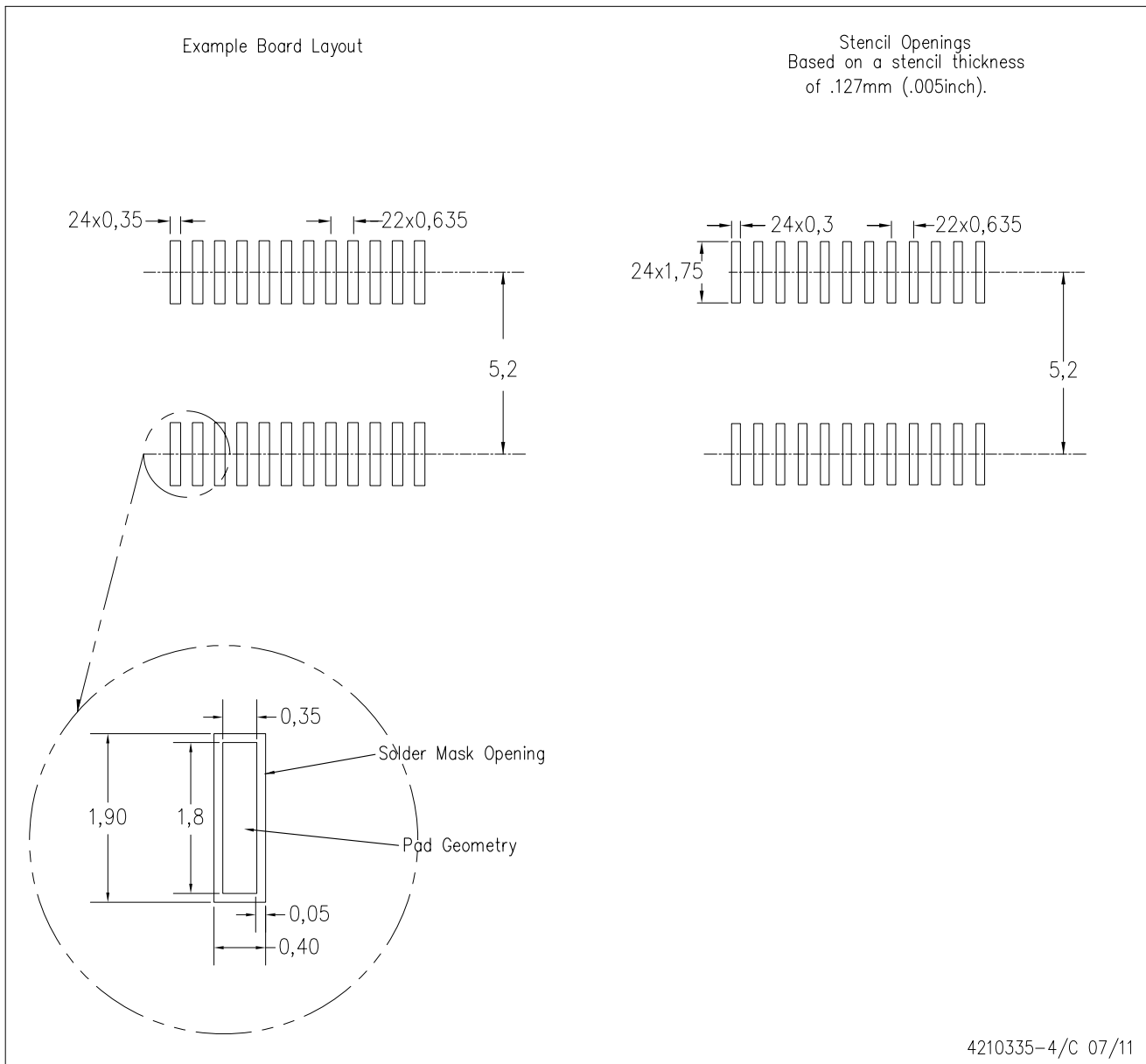

- NOTES:
- A. All linear dimensions are in millimeters.
 - B. This drawing is subject to change without notice.
 - C. Customers should place a note on the circuit board fabrication drawing not to alter the center solder mask defined pad.
 - D. Publication IPC-7351 is recommended for alternate designs.
 - E. Laser cutting apertures with trapezoidal walls and also rounding corners will offer better paste release. Customers should contact their board assembly site for stencil design recommendations. Example stencil design based on a 50% volumetric metal load solder paste. Refer to IPC-7525 for other stencil recommendations.

RGE (S-PVQFN-N24)

PLASTIC QUAD FLATPACK NO-LEAD

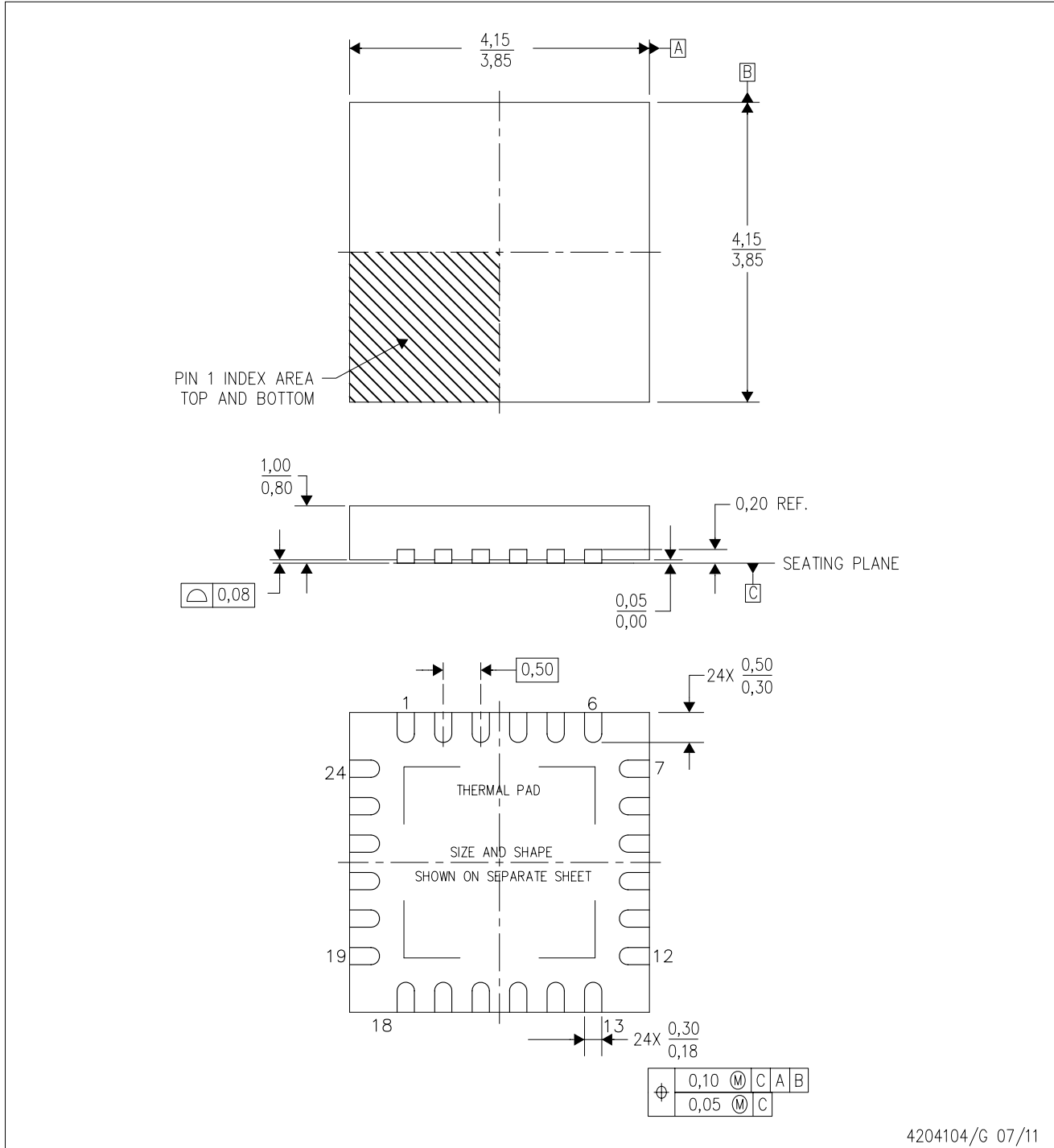

4204104/G 07/11

- NOTES:
- A. All linear dimensions are in millimeters. Dimensioning and tolerancing per ASME Y14.5M-1994.
 - B. This drawing is subject to change without notice.
 - C. Quad Flatpack, No-Leads (QFN) package configuration.
 - D. The package thermal pad must be soldered to the board for thermal and mechanical performance.
 - E. See the additional figure in the Product Data Sheet for details regarding the exposed thermal pad features and dimensions.
 - F. Falls within JEDEC MO-220.

THERMAL PAD MECHANICAL DATA

RGE (S-PVQFN-N24)

PLASTIC QUAD FLATPACK NO-LEAD

THERMAL INFORMATION

This package incorporates an exposed thermal pad that is designed to be attached directly to an external heatsink. The thermal pad must be soldered directly to the printed circuit board (PCB). After soldering, the PCB can be used as a heatsink. In addition, through the use of thermal vias, the thermal pad can be attached directly to the appropriate copper plane shown in the electrical schematic for the device, or alternatively, can be attached to a special heatsink structure designed into the PCB. This design optimizes the heat transfer from the integrated circuit (IC).

For information on the Quad Flatpack No-Lead (QFN) package and its advantages, refer to Application Report, QFN/SON PCB Attachment, Texas Instruments Literature No. SLUA271. This document is available at www.ti.com.

The exposed thermal pad dimensions for this package are shown in the following illustration.

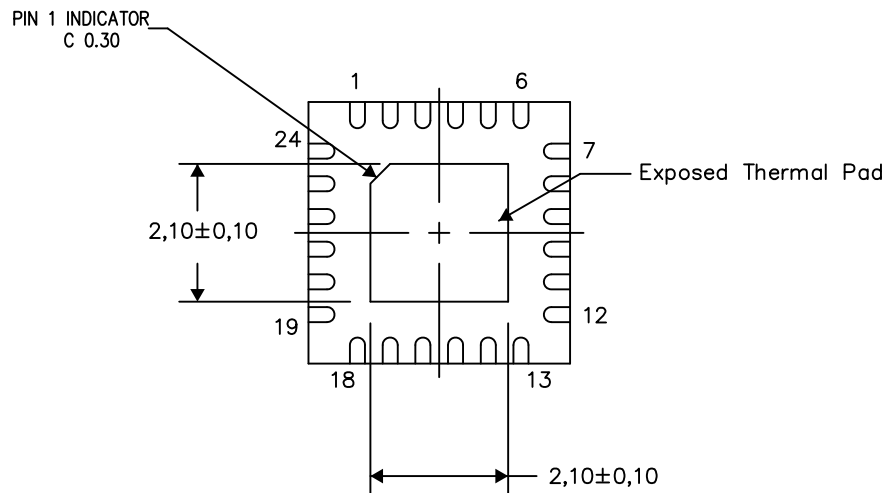

Bottom View

Exposed Thermal Pad Dimensions

4206344-6/AC 03/13

NOTES: A. All linear dimensions are in millimeters

RGE (S-PVQFN-N24)

PLASTIC QUAD FLATPACK NO-LEAD

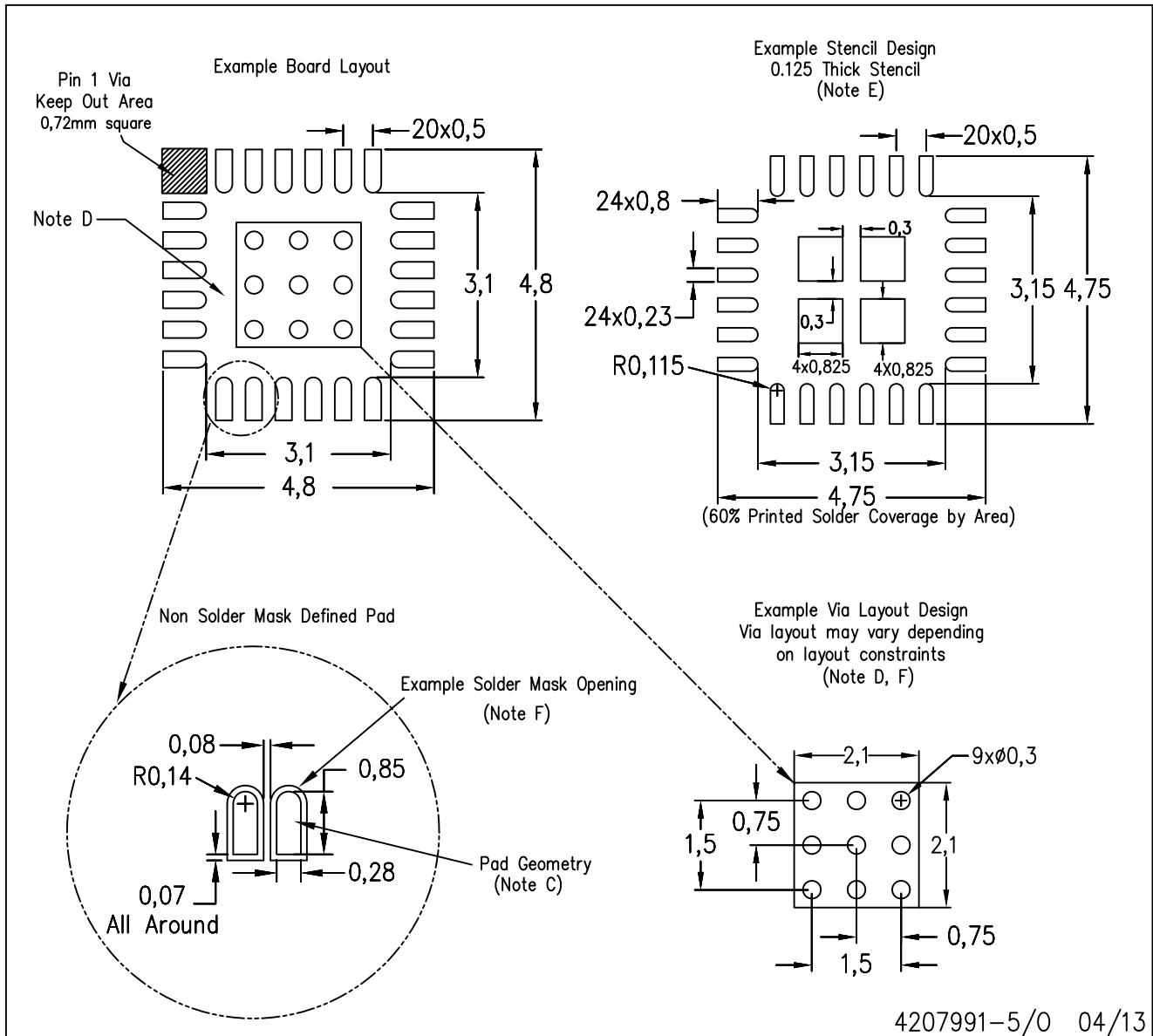

- NOTES:
- All linear dimensions are in millimeters.
 - This drawing is subject to change without notice.
 - Publication IPC-7351 is recommended for alternate designs.
 - This package is designed to be soldered to a thermal pad on the board. Refer to Application Note, Quad Flat-Pack Packages, Texas Instruments Literature No. SLUA271, and also the Product Data Sheets for specific thermal information, via requirements, and recommended board layout. These documents are available at www.ti.com <<http://www.ti.com>>.
 - Laser cutting apertures with trapezoidal walls and also rounding corners will offer better paste release. Customers should contact their board assembly site for stencil design recommendations. Refer to IPC 7525 for stencil design considerations.
 - Customers should contact their board fabrication site for recommended solder mask tolerances and via tenting recommendations for vias placed in the thermal pad.

IMPORTANT NOTICE

Texas Instruments Incorporated and its subsidiaries (TI) reserve the right to make corrections, enhancements, improvements and other changes to its semiconductor products and services per JESD46, latest issue, and to discontinue any product or service per JESD48, latest issue. Buyers should obtain the latest relevant information before placing orders and should verify that such information is current and complete. All semiconductor products (also referred to herein as "components") are sold subject to TI's terms and conditions of sale supplied at the time of order acknowledgment.

TI warrants performance of its components to the specifications applicable at the time of sale, in accordance with the warranty in TI's terms and conditions of sale of semiconductor products. Testing and other quality control techniques are used to the extent TI deems necessary to support this warranty. Except where mandated by applicable law, testing of all parameters of each component is not necessarily performed.

TI assumes no liability for applications assistance or the design of Buyers' products. Buyers are responsible for their products and applications using TI components. To minimize the risks associated with Buyers' products and applications, Buyers should provide adequate design and operating safeguards.

TI does not warrant or represent that any license, either express or implied, is granted under any patent right, copyright, mask work right, or other intellectual property right relating to any combination, machine, or process in which TI components or services are used. Information published by TI regarding third-party products or services does not constitute a license to use such products or services or a warranty or endorsement thereof. Use of such information may require a license from a third party under the patents or other intellectual property of the third party, or a license from TI under the patents or other intellectual property of TI.

Reproduction of significant portions of TI information in TI data books or data sheets is permissible only if reproduction is without alteration and is accompanied by all associated warranties, conditions, limitations, and notices. TI is not responsible or liable for such altered documentation. Information of third parties may be subject to additional restrictions.

Resale of TI components or services with statements different from or beyond the parameters stated by TI for that component or service voids all express and any implied warranties for the associated TI component or service and is an unfair and deceptive business practice. TI is not responsible or liable for any such statements.

Buyer acknowledges and agrees that it is solely responsible for compliance with all legal, regulatory and safety-related requirements concerning its products, and any use of TI components in its applications, notwithstanding any applications-related information or support that may be provided by TI. Buyer represents and agrees that it has all the necessary expertise to create and implement safeguards which anticipate dangerous consequences of failures, monitor failures and their consequences, lessen the likelihood of failures that might cause harm and take appropriate remedial actions. Buyer will fully indemnify TI and its representatives against any damages arising out of the use of any TI components in safety-critical applications.

In some cases, TI components may be promoted specifically to facilitate safety-related applications. With such components, TI's goal is to help enable customers to design and create their own end-product solutions that meet applicable functional safety standards and requirements. Nonetheless, such components are subject to these terms.

No TI components are authorized for use in FDA Class III (or similar life-critical medical equipment) unless authorized officers of the parties have executed a special agreement specifically governing such use.

Only those TI components which TI has specifically designated as military grade or "enhanced plastic" are designed and intended for use in military/aerospace applications or environments. Buyer acknowledges and agrees that any military or aerospace use of TI components which have **not** been so designated is solely at the Buyer's risk, and that Buyer is solely responsible for compliance with all legal and regulatory requirements in connection with such use.

TI has specifically designated certain components as meeting ISO/TS16949 requirements, mainly for automotive use. In any case of use of non-designated products, TI will not be responsible for any failure to meet ISO/TS16949.

Products

Audio	www.ti.com/audio
Amplifiers	amplifier.ti.com
Data Converters	dataconverter.ti.com
DLP® Products	www.dlp.com
DSP	dsp.ti.com
Clocks and Timers	www.ti.com/clocks
Interface	interface.ti.com
Logic	logic.ti.com
Power Mgmt	power.ti.com
Microcontrollers	microcontroller.ti.com
RFID	www.ti-rfid.com
OMAP Applications Processors	www.ti.com/omap
Wireless Connectivity	www.ti.com/wirelessconnectivity

Applications

Automotive and Transportation	www.ti.com/automotive
Communications and Telecom	www.ti.com/communications
Computers and Peripherals	www.ti.com/computers
Consumer Electronics	www.ti.com/consumer-apps
Energy and Lighting	www.ti.com/energy
Industrial	www.ti.com/industrial
Medical	www.ti.com/medical
Security	www.ti.com/security
Space, Avionics and Defense	www.ti.com/space-avionics-defense
Video and Imaging	www.ti.com/video

TI E2E Community

e2e.ti.com