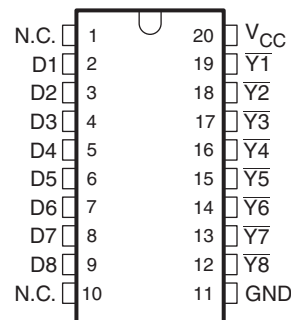

8-BIT DMOS SINK DRIVER

FEATURES

- DMOS Process
- High Voltage Output ($V_{ds} = 30\text{ V}$)
- Output Current on Each Channel ($I_{ds}\text{ Max} = 200\text{ mA}$)
- Latch-Up Performance Exceeds 250 mA Per JEDEC Standard JESD-17
- ESD Protection Exceeds JESD 22
 - 2000-V Human Body Model (A114-A)
 - 200-V Machine Model (A115-A)
 - 1000-V Charged Device Model (C101)
- LED Driver Application
- Output Clamp Diode (Parasitic)

**N OR PW PACKAGE
(TOP VIEW)**

N.C. – Not internally connected

APPLICATIONS

- Lamp and Display (LED)
- Hammer
- Relay

DESCRIPTION

The TLC59211 is an 8-bit LED and solenoid driver designed for 5-V V_{CC} operation.

The TLC59211 is characterized for operation from -40°C to 85°C .

ORDERING INFORMATION⁽¹⁾

T_A	PACKAGE ⁽²⁾		ORDERABLE PART NUMBER	TOP-SIDE MARKING
-40°C to 85°C	PDIP – N	Reel of 1000	TLC59211IN	Y59211
	TSSOP – PW	Reel of 2000	TLC59211IPWR	Y59211

(1) For the most current package and ordering information, see the Package Option Addendum at the end of this document, or see the TI web site at www.ti.com.

(2) Package drawings, thermal data, and symbolization are available at www.ti.com/packaging.

FUNCTION TABLE (EACH LATCH)⁽¹⁾

INPUTS	OUTPUT \bar{Y}
D	
L	H*
H	L

- (1) L: Low-level
H: High-level
H*: with pullup resistor



Please be aware that an important notice concerning availability, standard warranty, and use in critical applications of Texas Instruments semiconductor products and disclaimers thereto appears at the end of this data sheet.

OUTPUT SCHEMATIC

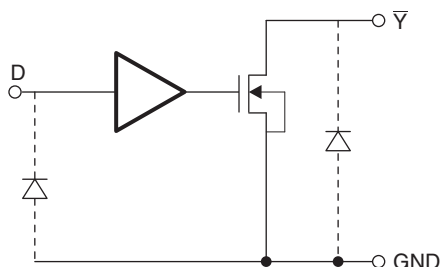

LOGIC SYMBOL ⁽¹⁾

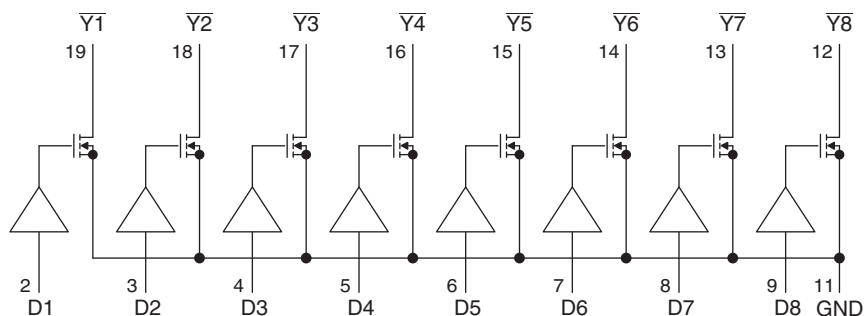

(1) This symbol is in accordance with ANSI/IEEE Standard 91-1984 and IEC Publication 617-12.

ABSOLUTE MAXIMUM RATINGS ⁽¹⁾

over operating free-air temperature range (unless otherwise noted)

		MIN	MAX	UNIT
V_{CC}	Supply voltage range	-0.5	7	V
D	Input voltage range	-0.5	7	V
V_{ds}	Output voltage range	H output		V
I_{ds}	Output current range	1 bit for output low		200 mA
I_{IK}	Input clamp current	$V_I < 0$ V		-20 mA
θ_{JA}	Package thermal impedance ⁽²⁾	N package		69
		PW package		83
Operating free-air temperature range		-40	85	°C
T_{stg}	Storage temperature range	-65	150	°C

- (1) Stresses beyond those listed under "absolute maximum ratings" may cause permanent damage to the device. These are stress ratings only, and functional operation of the device at these or any other conditions beyond those indicated under "recommended operating conditions" is not implied. Exposure to absolute-maximum-rated conditions for extended periods may affect device reliability.
- (2) The package thermal impedance is calculated in accordance with JESD 51-7.

RECOMMENDED OPERATING CONDITIONS

 $V_{CC} = 3\text{ V to }5.5\text{ V}$

		CONDITIONS		MIN	MAX	UNIT
V_{CC}	Supply voltage			3	5.5	V
V_{IH}	High-level input voltage			$V_{CC} \times 0.7$	V_{CC}	V
V_{IL}	Low-level input voltage			0	$V_{CC} \times 0.3$	V
V_{ds}	Output voltage				30	V
I_{ds}	Output current	N package	Duty cycle < 42%		200	mA
			Duty cycle < 100%		130	
		PW package	Duty cycle < 24%		200	
			Duty cycle < 100%		95	
T_A	Operating free-air temperature			-40	85	°C

ELECTRICAL CHARACTERISTICS

 over recommended operating free-air temperature range, $V_{CC} = 4.5\text{ V to }5.5\text{ V}$, $T_A = -40^\circ\text{C to }85^\circ\text{C}$ (unless otherwise noted)

PARAMETER	TEST CONDITIONS		MIN	TYP	MAX	UNIT
V_{t+}	Positive-going input threshold	D, $\overline{\text{CLR}}$, CLK			3.5	V
V_{t-}	Negative-going input threshold	D, $\overline{\text{CLR}}$, CLK	1.5			V
V_t	Hysteresis	D, $\overline{\text{CLR}}$, CLK	0.5		2	V
I_{IH}	High-level input current	$V_{CC} = 5.5\text{ V}$, $V_I = 5.5\text{ V}$		0	1	μA
I_{IL}	Low-level input current	$V_{CC} = 5.5\text{ V}$, $V_I = 0\text{ V}$		0	-1	μA
I_{OZ}	Leakage current	$V_{ds} = 30\text{ V}$			5	μA
I_{off}	Leakage current	$V_I = 0\text{ to }5\text{ V}$, $V_O = 0\text{ to }30\text{ V}$, $V_{CC} = 0$		0	5	μA
I_{CC}	Supply current	$V_I = 0\text{ to }5\text{ V}$, $V_O = 0\text{ to }30\text{ V}$, $V_{CC} = 0$	Output = all OFF	0	5	μA
			Output = all ON	0	5	
V_{OL}	Low-level output voltage	$V_{CC} = 4.5\text{ V}$, $I_O = 100\text{ mA}$		0.2	0.35	V
		$V_{CC} = 4.5\text{ V}$, $I_O = 200\text{ mA}$		0.5	0.7	V
r_{ON}	ON-state resistance	$V_{CC} = 4.5\text{ V}$, $I_O = 100\text{ mA}$		2	3.5	Ω
C_i	Input capacitance	$V_I = V_{CC}\text{ or GND}$		5		pF

SWITCHING CHARACTERISTICS

 over operating free-air temperature range, $V_{CC} = 4.5\text{ V to }5.5\text{ V}$, $T_A = -40^\circ\text{C to }85^\circ\text{C}$ (unless otherwise noted)

PARAMETER	TEST CONDITIONS	LOAD CAPACITANCE	$T_A = 25^\circ\text{C}$			$T_A = -40^\circ\text{C to }85^\circ\text{C}$		UNIT
			MIN	TYP	MAX	MIN	MAX	
t_{TLH}	Output = low to high	$C_L = 30\text{ pF}$, $R_L = 240\ \Omega$, 24-V pullup		180	220		260	ns
t_{THL}	Output = high to low	$C_L = 30\text{ pF}$, $R_L = 240\ \Omega$, 24-V pullup		290	430		460	ns
t_{PLH}	Output = low to high	$C_L = 30\text{ pF}$, $R_L = 240\ \Omega$, 24-V pullup		320	470		510	ns
t_{PHL}	Output = high to low	$C_L = 30\text{ pF}$, $R_L = 240\ \Omega$, 24-V pullup		320	470		510	ns

ELECTRICAL CHARACTERISTICS

over recommended operating free-air temperature range, $V_{CC} = 3\text{ V to }3.6\text{ V}$, $T_A = -40^\circ\text{C to }85^\circ\text{C}$ (unless otherwise noted)

PARAMETER		TEST CONDITIONS	MIN	TYP	MAX	UNIT	
V_{t+}	Positive-going input threshold	D			2.52	V	
V_{t-}	Negative-going input threshold	D	0.9			V	
V_t	Hysteresis	D	0.33		1.32	V	
I_{IH}	High-level input current	$V_{CC} = 3.6\text{ V}$, $V_I = 3.6\text{ V}$		0	1	μA	
I_{IL}	Low-level input current	$V_{CC} = 3.6\text{ V}$, $V_I = 0\text{ V}$		0	-1	μA	
I_{OZ}	Leakage current	$V_{ds} = 30\text{ V}$			5	μA	
I_{off}	Leakage current	$V_I = 0\text{ to }3.6\text{ V}$, $V_O = 0\text{ to }30\text{ V}$, $V_{CC} = 0$		0	5	μA	
I_{CC}	Supply current	$V_I = 0\text{ to }3.6\text{ V}$, $V_{CC} = 3.6\text{ V}$	Output = all OFF		0	5	μA
			Output = all ON		0	5	
V_{OL}	Low-level output voltage	$V_{CC} = 3\text{ V}$, $I_{OL} = 100\text{ mA}$			0.35	0.7	V
							V
r_{ON}	ON-state resistance	$V_{CC} = 3\text{ V}$, $I_O = 100\text{ mA}$		3.5	7	Ω	
C_i	Input capacitance	$V_I = V_{CC}\text{ or GND}$		5		pF	

SWITCHING CHARACTERISTICS

over operating free-air temperature range, $V_{CC} = 3\text{ V to }3.6\text{ V}$, $T_A = -40^\circ\text{C to }85^\circ\text{C}$ (unless otherwise noted)

PARAMETER	TEST CONDITIONS	LOAD CAPACITANCE	$T_A = 25^\circ\text{C}$			$T_A = -40^\circ\text{C to }85^\circ\text{C}$		UNIT
			MIN	TYP	MAX	MIN	MAX	
t_{TLH}	Output = low to high	$C_L = 30\text{ pF}$, $R_L = 240\ \Omega$, 24-V pullup		200	450		450	ns
t_{THL}	Output = high to low	$C_L = 30\text{ pF}$, $R_L = 240\ \Omega$, 24-V pullup		300	450		480	ns
t_{PLH}	Output = low to high	$C_L = 30\text{ pF}$, $R_L = 240\ \Omega$, 24-V pullup		450	650		800	ns
t_{PHL}	Output = high to low	$C_L = 30\text{ pF}$, $R_L = 240\ \Omega$, 24-V pullup		450	650		800	ns

THERMAL INFORMATION

MAXIMUM OUTPUT CURRENT

vs
DUTY CYCLE

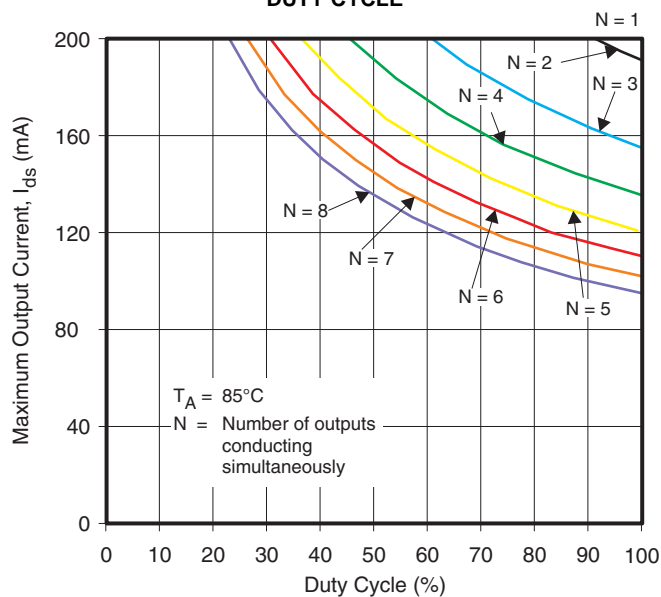

TSSOP (PW) PACKAGE

MAXIMUM OUTPUT CURRENT

vs
DUTY CYCLE

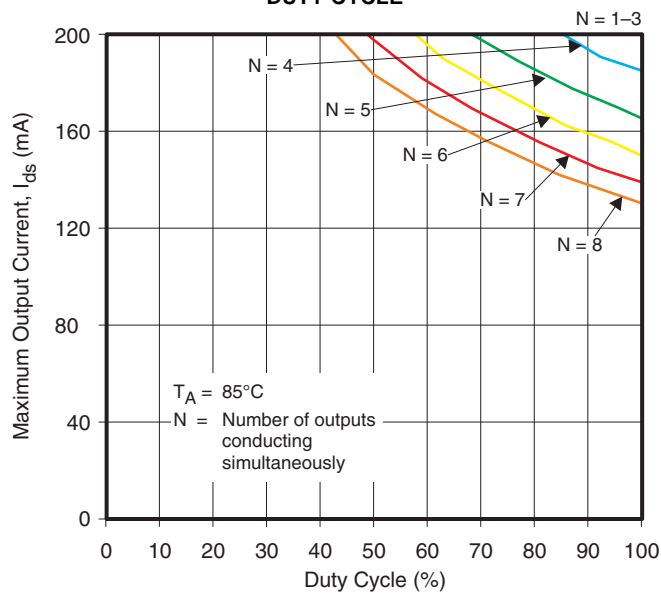

DIP (N) PACKAGE

PARAMETER MEASUREMENT INFORMATION

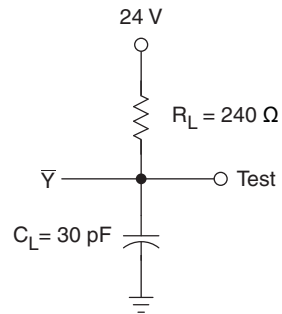

**LOAD CIRCUIT
FOR O/D OUTPUT**

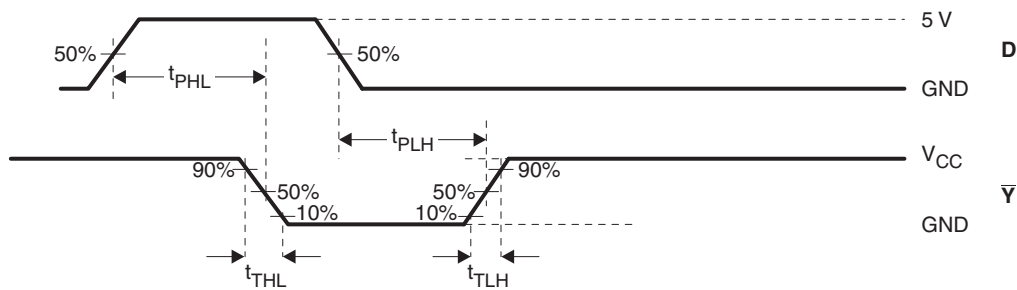

VOLTAGE WAVEFORMS

- A. C_L includes probe and jig capacitance.
- B. Waveform 1 is for an output with internal conditions such that the output is low except when disabled by the output control. Waveform 2 is for an output with internal conditions such that the output is high except when disabled by the output control.
- C. All input pulses are supplied by generators having the following characteristics: $PRR \leq 1 \text{ MHz}$, $Z_O = 50 \Omega$, $t_r \leq 3 \text{ ns}$, and $t_f \leq 3 \text{ ns}$.
- D. The outputs are measured one at a time with one transition per measurement.
- E. t_{PLH} and t_{PHL} are the same as t_{pd} .

Figure 1. Test Circuit and Voltage Waveforms

APPLICATION INFORMATION

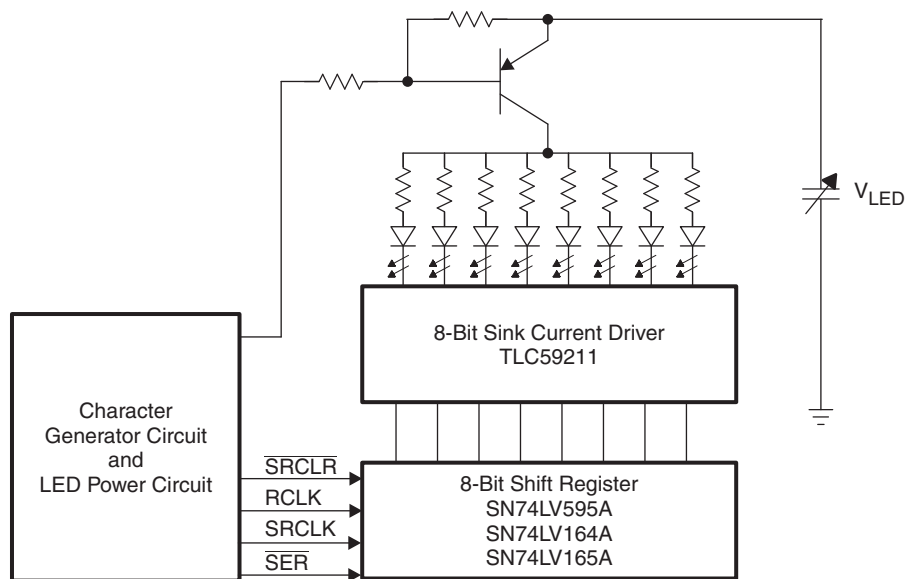

PACKAGING INFORMATION

Orderable Device	Status ⁽¹⁾	Package Type	Package Drawing	Pins	Package Qty	Eco Plan ⁽²⁾	Lead/Ball Finish	MSL Peak Temp ⁽³⁾
TLC59211IN	ACTIVE	PDIP	N	20	20	Pb-Free (RoHS)	CU NIPDAU	N / A for Pkg Type
TLC59211IPWR	ACTIVE	TSSOP	PW	20	2000	Green (RoHS & no Sb/Br)	CU NIPDAU	Level-1-260C-UNLIM

⁽¹⁾ The marketing status values are defined as follows:

ACTIVE: Product device recommended for new designs.

LIFEBUY: TI has announced that the device will be discontinued, and a lifetime-buy period is in effect.

NRND: Not recommended for new designs. Device is in production to support existing customers, but TI does not recommend using this part in a new design.

PREVIEW: Device has been announced but is not in production. Samples may or may not be available.

OBsolete: TI has discontinued the production of the device.

⁽²⁾ Eco Plan - The planned eco-friendly classification: Pb-Free (RoHS), Pb-Free (RoHS Exempt), or Green (RoHS & no Sb/Br) - please check <http://www.ti.com/productcontent> for the latest availability information and additional product content details.

TBD: The Pb-Free/Green conversion plan has not been defined.

Pb-Free (RoHS): TI's terms "Lead-Free" or "Pb-Free" mean semiconductor products that are compatible with the current RoHS requirements for all 6 substances, including the requirement that lead not exceed 0.1% by weight in homogeneous materials. Where designed to be soldered at high temperatures, TI Pb-Free products are suitable for use in specified lead-free processes.

Pb-Free (RoHS Exempt): This component has a RoHS exemption for either 1) lead-based flip-chip solder bumps used between the die and package, or 2) lead-based die adhesive used between the die and leadframe. The component is otherwise considered Pb-Free (RoHS compatible) as defined above.

Green (RoHS & no Sb/Br): TI defines "Green" to mean Pb-Free (RoHS compatible), and free of Bromine (Br) and Antimony (Sb) based flame retardants (Br or Sb do not exceed 0.1% by weight in homogeneous material)

⁽³⁾ MSL, Peak Temp. -- The Moisture Sensitivity Level rating according to the JEDEC industry standard classifications, and peak solder temperature.

Important Information and Disclaimer: The information provided on this page represents TI's knowledge and belief as of the date that it is provided. TI bases its knowledge and belief on information provided by third parties, and makes no representation or warranty as to the accuracy of such information. Efforts are underway to better integrate information from third parties. TI has taken and continues to take reasonable steps to provide representative and accurate information but may not have conducted destructive testing or chemical analysis on incoming materials and chemicals. TI and TI suppliers consider certain information to be proprietary, and thus CAS numbers and other limited information may not be available for release.

In no event shall TI's liability arising out of such information exceed the total purchase price of the TI part(s) at issue in this document sold by TI to Customer on an annual basis.

TAPE AND REEL INFORMATION



QUADRANT ASSIGNMENTS FOR PIN 1 ORIENTATION IN TAPE



*All dimensions are nominal

Device	Package Type	Package Drawing	Pins	SPQ	Reel Diameter (mm)	Reel Width W1 (mm)	A0 (mm)	B0 (mm)	K0 (mm)	P1 (mm)	W (mm)	Pin1 Quadrant
TLC59211IPWR	TSSOP	PW	20	2000	330.0	16.4	6.95	7.1	1.6	8.0	16.0	Q1

TAPE AND REEL BOX DIMENSIONS



*All dimensions are nominal

Device	Package Type	Package Drawing	Pins	SPQ	Length (mm)	Width (mm)	Height (mm)
TLC59211PWR	TSSOP	PW	20	2000	346.0	346.0	33.0

PW (R-PDSO-G**)

PLASTIC SMALL-OUTLINE PACKAGE

14 PINS SHOWN

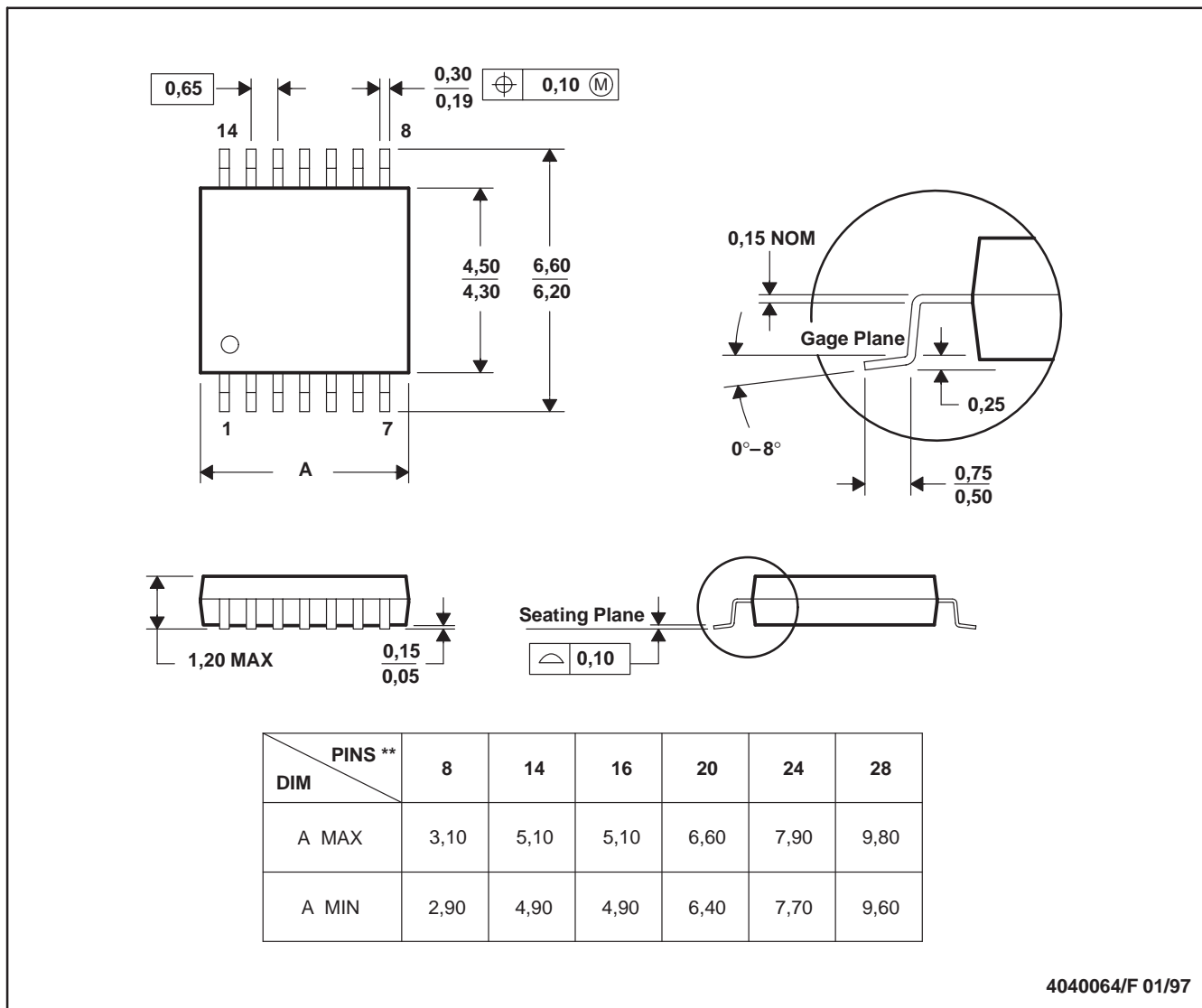

4040064/F 01/97

- NOTES: A. All linear dimensions are in millimeters.
 B. This drawing is subject to change without notice.
 C. Body dimensions do not include mold flash or protrusion not to exceed 0,15.
 D. Falls within JEDEC MO-153

IMPORTANT NOTICE

Texas Instruments Incorporated and its subsidiaries (TI) reserve the right to make corrections, modifications, enhancements, improvements, and other changes to its products and services at any time and to discontinue any product or service without notice. Customers should obtain the latest relevant information before placing orders and should verify that such information is current and complete. All products are sold subject to TI's terms and conditions of sale supplied at the time of order acknowledgment.

TI warrants performance of its hardware products to the specifications applicable at the time of sale in accordance with TI's standard warranty. Testing and other quality control techniques are used to the extent TI deems necessary to support this warranty. Except where mandated by government requirements, testing of all parameters of each product is not necessarily performed.

TI assumes no liability for applications assistance or customer product design. Customers are responsible for their products and applications using TI components. To minimize the risks associated with customer products and applications, customers should provide adequate design and operating safeguards.

TI does not warrant or represent that any license, either express or implied, is granted under any TI patent right, copyright, mask work right, or other TI intellectual property right relating to any combination, machine, or process in which TI products or services are used. Information published by TI regarding third-party products or services does not constitute a license from TI to use such products or services or a warranty or endorsement thereof. Use of such information may require a license from a third party under the patents or other intellectual property of the third party, or a license from TI under the patents or other intellectual property of TI.

Reproduction of TI information in TI data books or data sheets is permissible only if reproduction is without alteration and is accompanied by all associated warranties, conditions, limitations, and notices. Reproduction of this information with alteration is an unfair and deceptive business practice. TI is not responsible or liable for such altered documentation. Information of third parties may be subject to additional restrictions.

Resale of TI products or services with statements different from or beyond the parameters stated by TI for that product or service voids all express and any implied warranties for the associated TI product or service and is an unfair and deceptive business practice. TI is not responsible or liable for any such statements.

TI products are not authorized for use in safety-critical applications (such as life support) where a failure of the TI product would reasonably be expected to cause severe personal injury or death, unless officers of the parties have executed an agreement specifically governing such use. Buyers represent that they have all necessary expertise in the safety and regulatory ramifications of their applications, and acknowledge and agree that they are solely responsible for all legal, regulatory and safety-related requirements concerning their products and any use of TI products in such safety-critical applications, notwithstanding any applications-related information or support that may be provided by TI. Further, Buyers must fully indemnify TI and its representatives against any damages arising out of the use of TI products in such safety-critical applications.

TI products are neither designed nor intended for use in military/aerospace applications or environments unless the TI products are specifically designated by TI as military-grade or "enhanced plastic." Only products designated by TI as military-grade meet military specifications. Buyers acknowledge and agree that any such use of TI products which TI has not designated as military-grade is solely at the Buyer's risk, and that they are solely responsible for compliance with all legal and regulatory requirements in connection with such use.

TI products are neither designed nor intended for use in automotive applications or environments unless the specific TI products are designated by TI as compliant with ISO/TS 16949 requirements. Buyers acknowledge and agree that, if they use any non-designated products in automotive applications, TI will not be responsible for any failure to meet such requirements.

Following are URLs where you can obtain information on other Texas Instruments products and application solutions:

Products		Applications	
Amplifiers	amplifier.ti.com	Audio	www.ti.com/audio
Data Converters	dataconverter.ti.com	Automotive	www.ti.com/automotive
DLP® Products	www.dlp.com	Communications and Telecom	www.ti.com/communications
DSP	dsp.ti.com	Computers and Peripherals	www.ti.com/computers
Clocks and Timers	www.ti.com/clocks	Consumer Electronics	www.ti.com/consumer-apps
Interface	interface.ti.com	Energy	www.ti.com/energy
Logic	logic.ti.com	Industrial	www.ti.com/industrial
Power Mgmt	power.ti.com	Medical	www.ti.com/medical
Microcontrollers	microcontroller.ti.com	Security	www.ti.com/security
RFID	www.ti-rfid.com	Space, Avionics & Defense	www.ti.com/space-avionics-defense
RF/IF and ZigBee® Solutions	www.ti.com/lprf	Video and Imaging	www.ti.com/video
		Wireless	www.ti.com/wireless-apps

Mailing Address: Texas Instruments, Post Office Box 655303, Dallas, Texas 75265
Copyright © 2010, Texas Instruments Incorporated