

- Temperature Compensated
- Programmable Output Voltage
- Low Output Resistance
- Low Output Noise
- Sink Capability up to 100 mA

LP PACKAGE
(TOP VIEW)

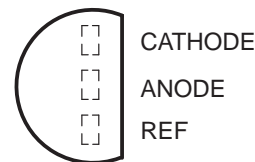

description/ordering information

The TL430 is a 3-terminal adjustable shunt regulator, featuring excellent temperature stability, wide operating current range, and low output noise. The output voltage can be set by two external resistors to any desired value between 3 V and 30 V. The TL430 can replace Zener diodes in many applications, providing improved performance.

The TL430C is characterized for operation from 0°C to 70°C.

ORDERING INFORMATION

T _A	PACKAGE†	ORDERABLE PART NUMBER	TOP-SIDE MARKING
0°C to 70°C	TO-226 / TO-92 (LP)	Bulk of 1000	TL430CLP
		Reel of 2000	TL430CLPR
			TL430C

† Package drawings, standard packing quantities, thermal data, symbolization, and PCB design guidelines are available at www.ti.com/sc/package.

symbol



Please be aware that an important notice concerning availability, standard warranty, and use in critical applications of Texas Instruments semiconductor products and disclaimers thereto appears at the end of this data sheet.

PRODUCTION DATA information is current as of publication date. Products conform to specifications per the terms of Texas Instruments standard warranty. Production processing does not necessarily include testing of all parameters.

**TEXAS
INSTRUMENTS**

POST OFFICE BOX 655303 • DALLAS, TEXAS 75265

Copyright © 2005, Texas Instruments Incorporated

TL430

ADJUSTABLE SHUNT REGULATORS

SLVS050D – JUNE 1976 – REVISED JANUARY 2005

absolute maximum ratings over operating free-air temperature range (unless otherwise noted)†

Regulator voltage (see Note 1)	30 V
Continuous regulator current	150 mA
Package thermal impedance, θ_{JA} (see Notes 2 and 3)	140°C/W
Operating virtual junction temperature, T_J	150°C
Lead temperature 1,6 mm (1/16 inch) from case for 10 seconds	260°C
Storage temperature range, T_{stg}	-65°C to 150°C

† Stresses beyond those listed under “absolute maximum ratings” may cause permanent damage to the device. These are stress ratings only, and functional operation of the device at these or any other conditions beyond those indicated under “recommended operating conditions” is not implied. Exposure to absolute-maximum-rated conditions for extended periods may affect device reliability.

NOTES: 1. All voltage values are with respect to the anode terminal.

- Maximum power dissipation is a function of $T_J(\text{max})$, θ_{JA} , and T_A . The maximum allowable power dissipation at any allowable ambient temperature is $P_D = (T_J(\text{max}) - T_A)/\theta_{JA}$. Operating at the absolute maximum T_J of 150°C can impact reliability.
- The package thermal impedance is calculated in accordance with JESD 51-7.

recommended operating conditions

		MIN	MAX	UNIT
V_Z	Regulator voltage	V_{ref}	30	V
I_Z	Regulator current	2	100	mA
T_A	Operating free-air temperature range	TL430C		°C

electrical characteristics over recommended operating conditions, $T_A = 25^\circ\text{C}$ (unless otherwise noted)

PARAMETER	TEST FIGURE	TEST CONDITIONS	TL430C			UNIT
			MIN	TYP	MAX	
$V_{I(\text{ref})}$	1	$V_Z = V_{I(\text{ref})}$, $I_Z = 10 \text{ mA}$	2.5	2.75	3	V
$\alpha V_{I(\text{ref})}$	1	$V_Z = V_{I(\text{ref})}$, $I_Z = 10 \text{ mA}$, $T_A = 0^\circ\text{C}$ to 70°C	120			ppm/°C
$I_{I(\text{ref})}$	2	$I_Z = 10 \text{ mA}$, $R_1 = 10 \text{ k}\Omega$, $R_2 = \infty$	3 10			μA
I_{ZK}	1	$V_Z = V_{I(\text{ref})}$	0.5 2			mA
I_{ZK}	1	$V_Z = V_{I(\text{ref})}$	50			mA
	2	$V_Z = 5 \text{ V}$ to 30 V , See Note 4	100			
r_z	1	$V_Z = V_{I(\text{ref})}$, $\Delta I_Z = (52 - 2) \text{ mA}$	1.5 3			Ω
V_n	2	$f = 0.1 \text{ Hz}$ to 10 Hz	$V_Z = 3 \text{ V}$			μV
			$V_Z = 12 \text{ V}$			
			$V_Z = 30 \text{ V}$			

NOTES: 4. The average power dissipation, $V_Z \cdot I_Z \cdot \text{duty cycle}$, must not exceed the maximum continuous rating in any 10-ms interval.

5. The regulator resistance for $V_Z > V_{I(\text{ref})}$, r_z , is given by:

$$r_z' = r_z \left(1 + \frac{R_1}{R_2} \right)$$



PARAMETER MEASUREMENT INFORMATION

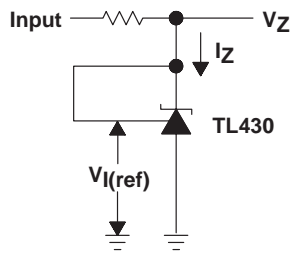
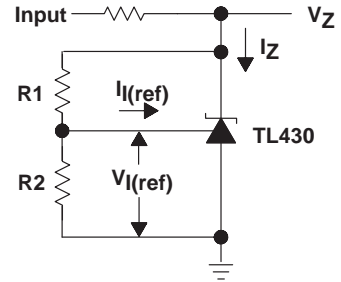

Figure 1. Test Circuit for $V_Z = V_{I(ref)}$



$$V_Z = V_{I(ref)} \left(1 + \frac{R1}{R2} \right) + I_{I(ref)} \times R1$$

Figure 2. Test Circuit for $V_Z > V_{I(ref)}$

TL430 ADJUSTABLE SHUNT REGULATORS

SLVS050D – JUNE 1976 – REVISED JANUARY 2005

TYPICAL CHARACTERISTICS

SMALL-SIGNAL REGULATOR IMPEDANCE
vs
FREQUENCY

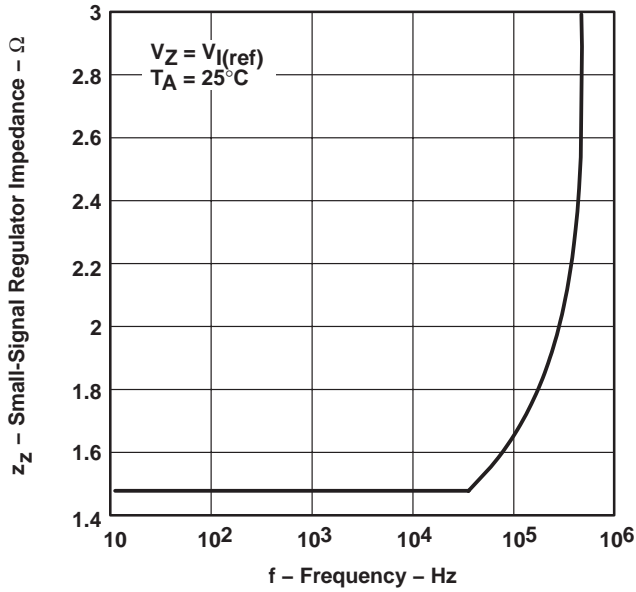

Figure 3

CATHODE CURRENT
vs
CATHODE VOLTAGE

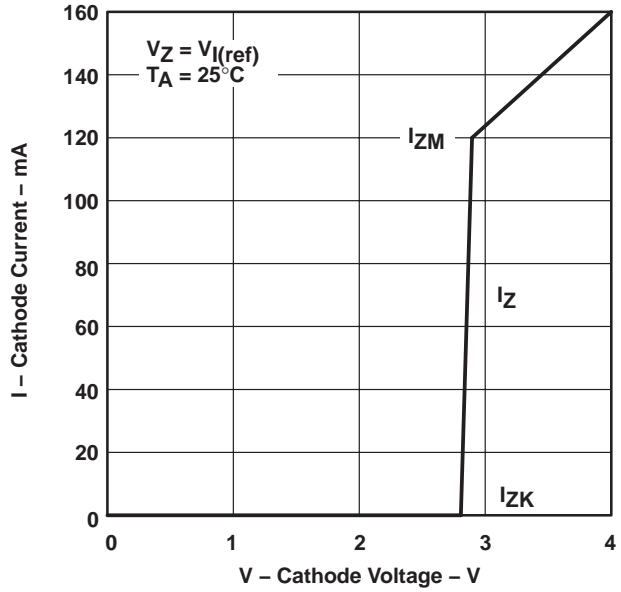
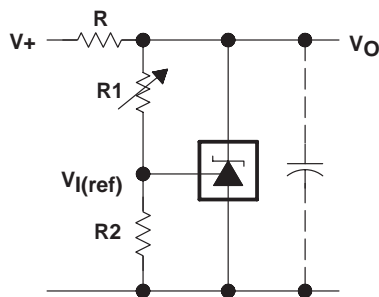

Figure 4

APPLICATION INFORMATION



$$V_O \approx \left(1 + \frac{R1}{R2}\right) V_{I(ref)}$$

Figure 5. Shunt Regulator

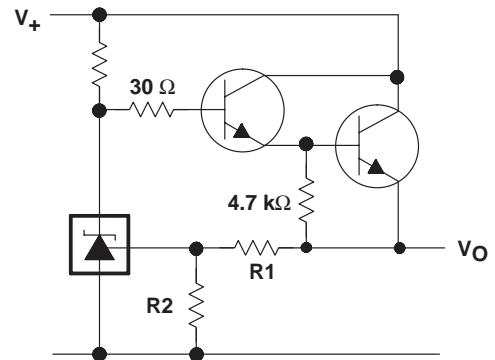

$$V_O \approx \left(1 + \frac{R1}{R2}\right) V_{I(ref)}$$

Figure 6. Series Regulator

APPLICATION INFORMATION

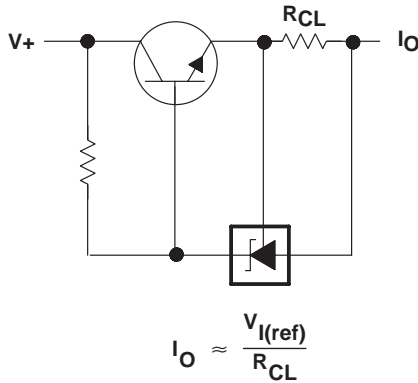
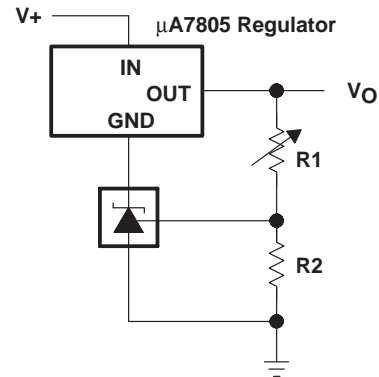

Figure 7. Current Limiter



$$V_O = \left(1 + \frac{R_1}{R_2}\right) V_{I(\text{ref})}$$

$$\text{Min } V_O = V_{I(\text{ref})} + 5V$$

Figure 8. Output Control of a 3-Terminal Fixed Regulator

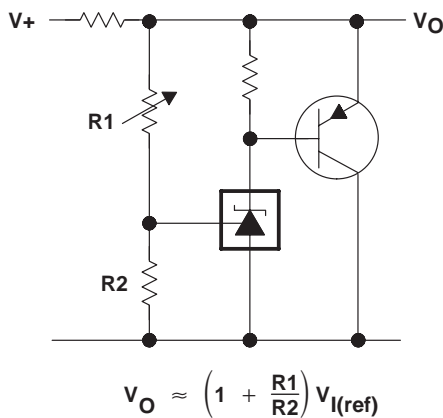

Figure 9. Higher-Current Applications

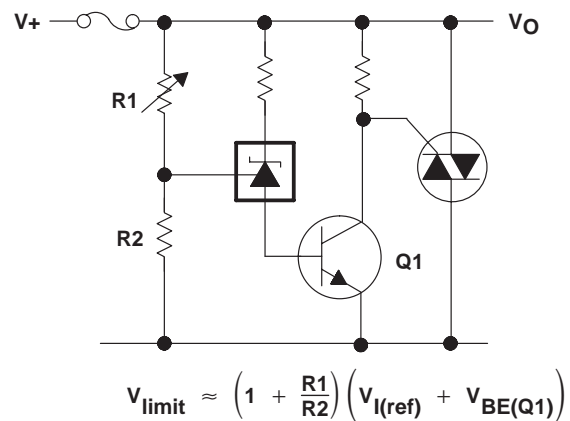

Figure 10. Crowbar

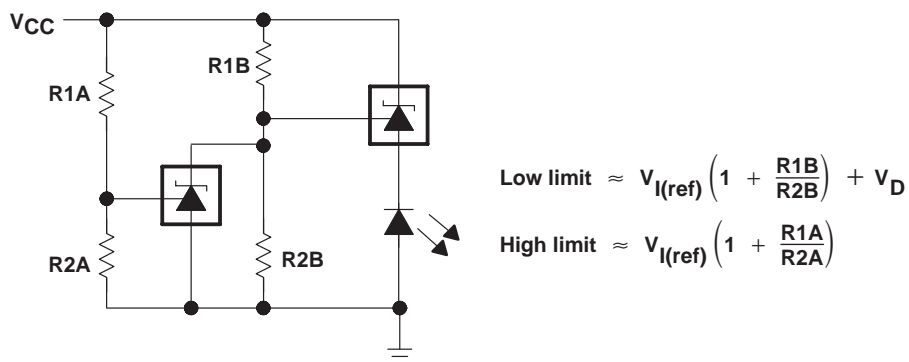

Figure 11. V_{CC} Monitor

PACKAGING INFORMATION

Orderable Device	Status ⁽¹⁾	Package Type	Package Drawing	Pins	Package Qty	Eco Plan ⁽²⁾	Lead/Ball Finish	MSL Peak Temp ⁽³⁾
TL430CLP	ACTIVE	TO-92	LP	3	1000	Pb-Free (RoHS)	CU SN	N / A for Pkg Type
TL430CLPE3	ACTIVE	TO-92	LP	3	1000	Pb-Free (RoHS)	CU SN	N / A for Pkg Type
TL430CLPR	ACTIVE	TO-92	LP	3	2000	Pb-Free (RoHS)	CU SN	N / A for Pkg Type
TL430CLPRE3	ACTIVE	TO-92	LP	3	2000	Pb-Free (RoHS)	CU SN	N / A for Pkg Type
TL430ILP	OBSOLETE	TO-92	LP	3		TBD	Call TI	Call TI

⁽¹⁾ The marketing status values are defined as follows:

ACTIVE: Product device recommended for new designs.

LIFEBUY: TI has announced that the device will be discontinued, and a lifetime-buy period is in effect.

NRND: Not recommended for new designs. Device is in production to support existing customers, but TI does not recommend using this part in a new design.

PREVIEW: Device has been announced but is not in production. Samples may or may not be available.

OBSOLETE: TI has discontinued the production of the device.

⁽²⁾ Eco Plan - The planned eco-friendly classification: Pb-Free (RoHS), Pb-Free (RoHS Exempt), or Green (RoHS & no Sb/Br) - please check <http://www.ti.com/productcontent> for the latest availability information and additional product content details.

TBD: The Pb-Free/Green conversion plan has not been defined.

Pb-Free (RoHS): TI's terms "Lead-Free" or "Pb-Free" mean semiconductor products that are compatible with the current RoHS requirements for all 6 substances, including the requirement that lead not exceed 0.1% by weight in homogeneous materials. Where designed to be soldered at high temperatures, TI Pb-Free products are suitable for use in specified lead-free processes.

Pb-Free (RoHS Exempt): This component has a RoHS exemption for either 1) lead-based flip-chip solder bumps used between the die and package, or 2) lead-based die adhesive used between the die and leadframe. The component is otherwise considered Pb-Free (RoHS compatible) as defined above.

Green (RoHS & no Sb/Br): TI defines "Green" to mean Pb-Free (RoHS compatible), and free of Bromine (Br) and Antimony (Sb) based flame retardants (Br or Sb do not exceed 0.1% by weight in homogeneous material)

⁽³⁾ MSL, Peak Temp. -- The Moisture Sensitivity Level rating according to the JEDEC industry standard classifications, and peak solder temperature.

Important Information and Disclaimer:The information provided on this page represents TI's knowledge and belief as of the date that it is provided. TI bases its knowledge and belief on information provided by third parties, and makes no representation or warranty as to the accuracy of such information. Efforts are underway to better integrate information from third parties. TI has taken and continues to take reasonable steps to provide representative and accurate information but may not have conducted destructive testing or chemical analysis on incoming materials and chemicals. TI and TI suppliers consider certain information to be proprietary, and thus CAS numbers and other limited information may not be available for release.

In no event shall TI's liability arising out of such information exceed the total purchase price of the TI part(s) at issue in this document sold by TI to Customer on an annual basis.

LP (O-PBCY-W3)

PLASTIC CYLINDRICAL PACKAGE

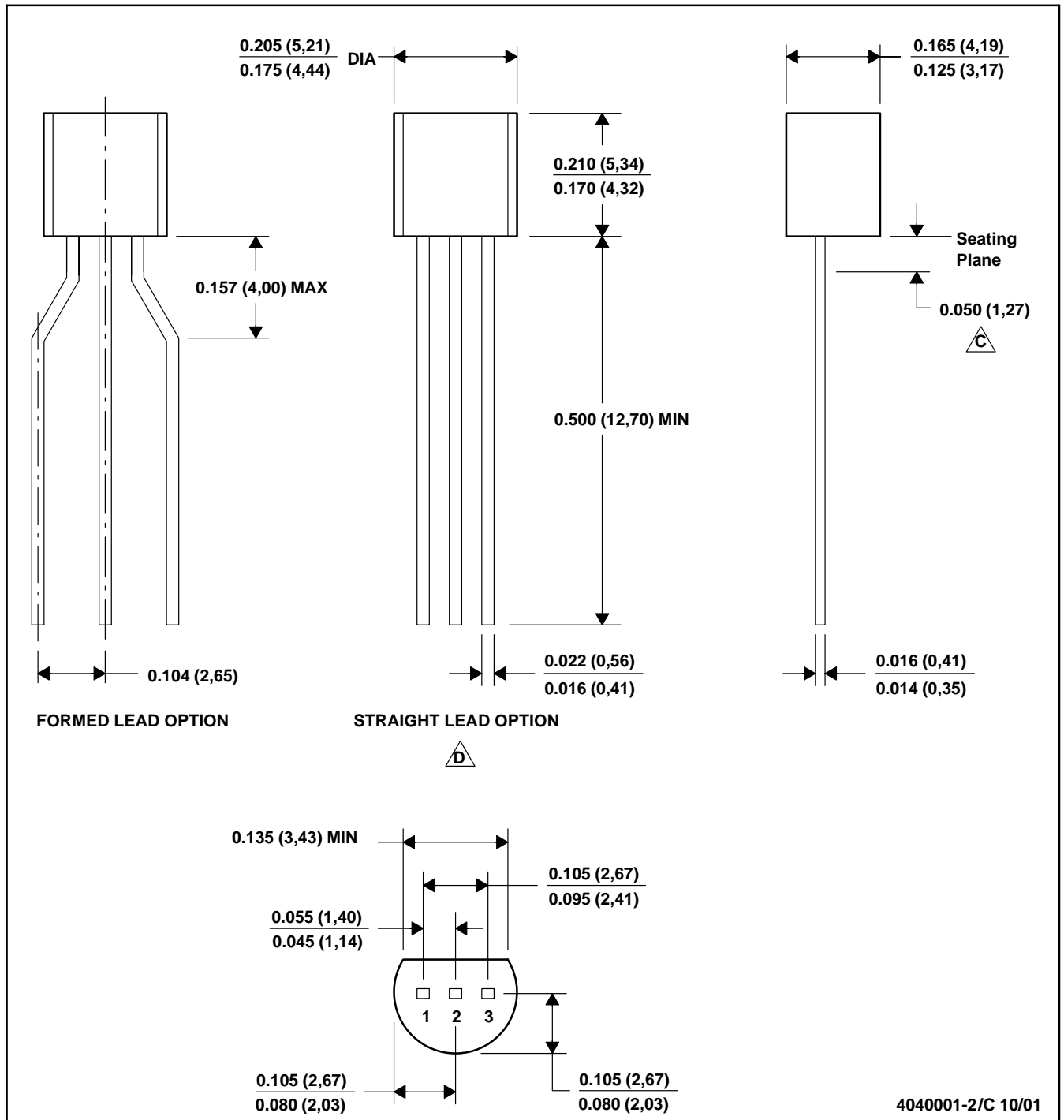

4040001-2/C 10/01

- NOTES: A. All linear dimensions are in inches (millimeters).
 B. This drawing is subject to change without notice.
 C. Lead dimensions are not controlled within this area
 D. Falls within JEDEC TO -226 Variation AA (TO-226 replaces TO-92)
 E. Shipping Method:
 Straight lead option available in bulk pack only.
 Formed lead option available in tape & reel or ammo pack.



MECHANICAL DATA

MSOT002A – OCTOBER 1994 – REVISED NOVEMBER 2001

LP (O-PBCY-W3)

PLASTIC CYLINDRICAL PACKAGE

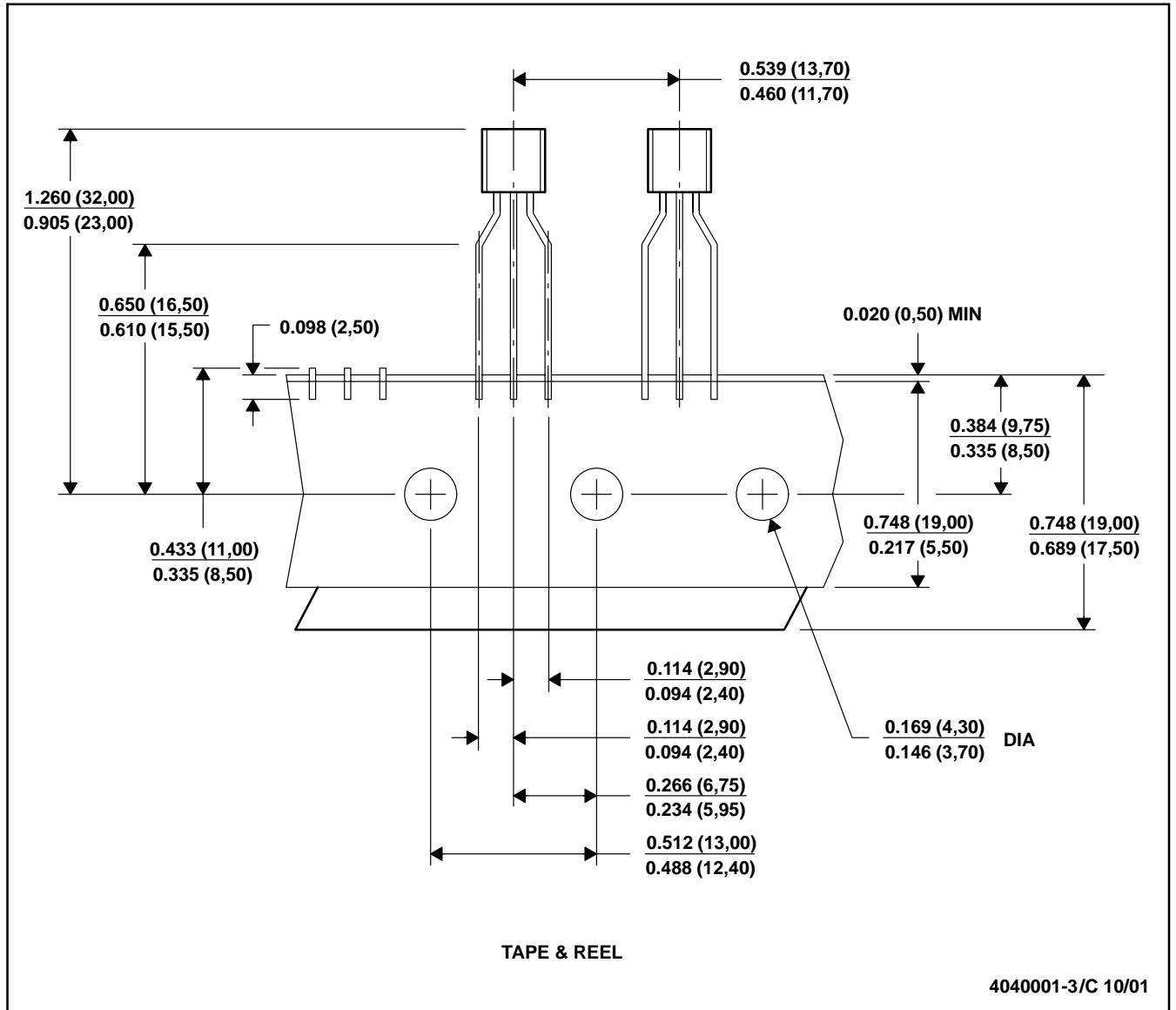

- NOTES: A. All linear dimensions are in inches (millimeters).
 B. This drawing is subject to change without notice.
 C. Tape and Reel information for the Format Lead Option package.

IMPORTANT NOTICE

Texas Instruments Incorporated and its subsidiaries (TI) reserve the right to make corrections, modifications, enhancements, improvements, and other changes to its products and services at any time and to discontinue any product or service without notice. Customers should obtain the latest relevant information before placing orders and should verify that such information is current and complete. All products are sold subject to TI's terms and conditions of sale supplied at the time of order acknowledgment.

TI warrants performance of its hardware products to the specifications applicable at the time of sale in accordance with TI's standard warranty. Testing and other quality control techniques are used to the extent TI deems necessary to support this warranty. Except where mandated by government requirements, testing of all parameters of each product is not necessarily performed.

TI assumes no liability for applications assistance or customer product design. Customers are responsible for their products and applications using TI components. To minimize the risks associated with customer products and applications, customers should provide adequate design and operating safeguards.

TI does not warrant or represent that any license, either express or implied, is granted under any TI patent right, copyright, mask work right, or other TI intellectual property right relating to any combination, machine, or process in which TI products or services are used. Information published by TI regarding third-party products or services does not constitute a license from TI to use such products or services or a warranty or endorsement thereof. Use of such information may require a license from a third party under the patents or other intellectual property of the third party, or a license from TI under the patents or other intellectual property of TI.

Reproduction of information in TI data books or data sheets is permissible only if reproduction is without alteration and is accompanied by all associated warranties, conditions, limitations, and notices. Reproduction of this information with alteration is an unfair and deceptive business practice. TI is not responsible or liable for such altered documentation.

Resale of TI products or services with statements different from or beyond the parameters stated by TI for that product or service voids all express and any implied warranties for the associated TI product or service and is an unfair and deceptive business practice. TI is not responsible or liable for any such statements.

Following are URLs where you can obtain information on other Texas Instruments products and application solutions:

Products		Applications	
Amplifiers	amplifier.ti.com	Audio	www.ti.com/audio
Data Converters	dataconverter.ti.com	Automotive	www.ti.com/automotive
DSP	dsp.ti.com	Broadband	www.ti.com/broadband
Interface	interface.ti.com	Digital Control	www.ti.com/digitalcontrol
Logic	logic.ti.com	Military	www.ti.com/military
Power Mgmt	power.ti.com	Optical Networking	www.ti.com/opticalnetwork
Microcontrollers	microcontroller.ti.com	Security	www.ti.com/security
Low Power Wireless	www.ti.com/lpw	Telephony	www.ti.com/telephony
		Video & Imaging	www.ti.com/video
		Wireless	www.ti.com/wireless

Mailing Address: Texas Instruments
Post Office Box 655303 Dallas, Texas 75265