

FEATURES

- **0.4% Initial Voltage Tolerance**
- **0.2-Ω Typical Output Impedance**
- **Fast Turnon...500 ns**
- **Sink Current Capability...1 mA to 100 mA**
- **Low Reference Current (REF)**
- **Adjustable Output Voltage... $V_{I(\text{ref})}$ to 36 V**

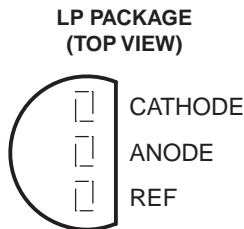
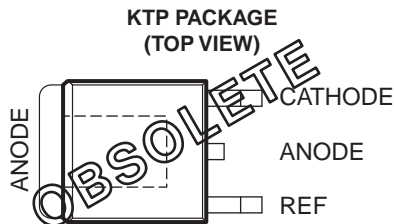
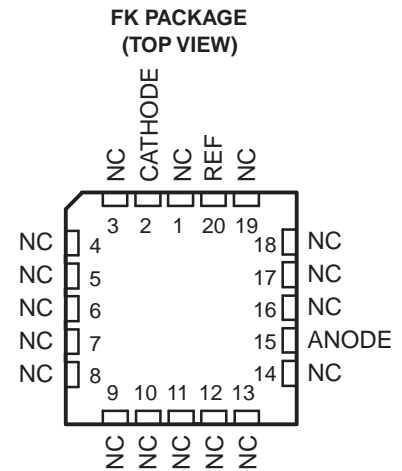
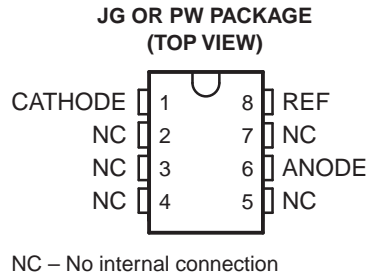
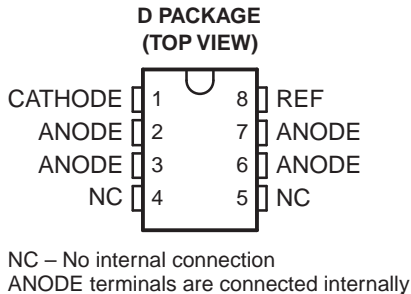

DESCRIPTION/ORDERING INFORMATION

The TL1431 is a precision programmable reference with specified thermal stability over automotive, commercial, and military temperature ranges. The output voltage can be set to any value between $V_{I(\text{ref})}$ (approximately 2.5 V) and 36 V with two external resistors (see Figure 16). This device has a typical output impedance of 0.2 Ω. Active output circuitry provides a very sharp turnon characteristic, making the device an excellent replacement for Zener diodes and other types of references in applications such as onboard regulation, adjustable power supplies, and switching power supplies.

The TL1431C is characterized for operation over the commercial temperature range of 0°C to 70°C. The TL1431Q is characterized for operation over the full automotive temperature range of –40°C to 125°C. The TL1431M is characterized for operation over the full military temperature range of –55°C to 125°C.



Please be aware that an important notice concerning availability, standard warranty, and use in critical applications of Texas Instruments semiconductor products and disclaimers thereto appears at the end of this data sheet.

PowerFLEX is a trademark of Texas Instruments.

ORDERING INFORMATION⁽¹⁾

T_A	PACKAGE ⁽²⁾		ORDERABLE PART NUMBER	TOP-SIDE MARKING
0°C to 70°C	PowerFLEX™ – KTP	Reel of 3000	TL1431CKTPR	OBSOLETE
	SOIC – D	Tube of 75	TL1431CD	1431C
		Reel of 2500	TL1431CDR	
	TO-226 / TO-92 – LP	Bulk of 1000	TL1431CLP	TL1431C
		Reel of 2000	TL1431CLPR	
	TSSOP – PW	Tube of 150	TL1431CPW	T1431
Reel of 2000		TL1431CPWR		
–40°C to 125°C	SOIC – D	Tube of 75	TL1431QD	TL1431QD
		Reel of 2500	TL1431QDR	
	TSSOP – PW	Tube of 150	TL1431QPW	T1431QPW
		Reel of 2000	TL1431QPWR	
–55°C to 125°C	CDIP – JG	Tube of 50	TL1431MJG	TL1431MJG
	LCCC – FK	Tube of 55	TL1431MFK	TL1431MFK

- (1) For the most current package and ordering information, see the Package Option Addendum at the end of this document, or see the TI web site at www.ti.com.
(2) Package drawings, thermal data, and symbolization are available at www.ti.com/packaging.

SYMBOL

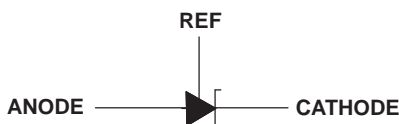

FUNCTIONAL BLOCK DIAGRAM

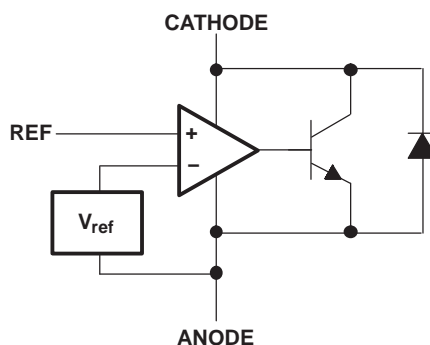

EQUIVALENT SCHEMATIC

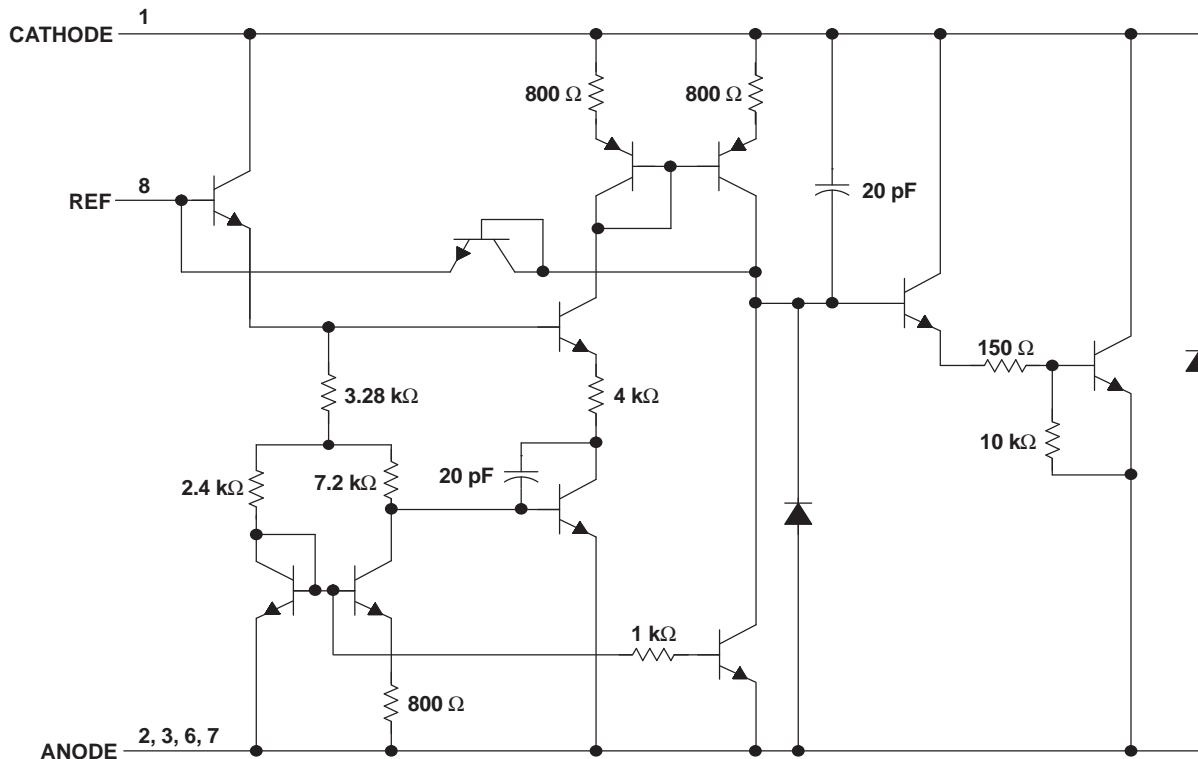

- A. All component values are nominal.
- B. Pin numbers shown are for the D package.

Absolute Maximum Ratings⁽¹⁾

over operating free-air temperature range (unless otherwise noted)

		MIN	MAX	UNIT
V_{KA}	Cathode voltage ⁽²⁾		37	V
I_{KA}	Continuous cathode current range	-100	150	mA
$I_{I(ref)}$	Reference input current range	-0.05	10	mA
θ_{JA}	Package thermal impedance ⁽³⁾⁽⁴⁾	D package	97	°C/W
		LP package	140	
		PW package	149	
θ_{JC}	Package thermal impedance ⁽⁵⁾⁽⁶⁾	FK package	5.61	°C/W
		JG package	14.5	
T_J	Operating virtual junction temperature		150	°C
	Lead temperature	1,6 mm (1/16 in) from case for 10 s	260	°C
T_{stg}	Storage temperature range	-65	150	°C

- (1) Stresses beyond those listed under "absolute maximum ratings" may cause permanent damage to the device. These are stress ratings only, and functional operation of the device at these or any other conditions beyond those indicated under "recommended operating conditions" is not implied. Exposure to absolute-maximum-rated conditions for extended periods may affect device reliability.
- (2) All voltage values are with respect to ANODE, unless otherwise noted.
- (3) Maximum power dissipation is a function of $T_{J(max)}$, θ_{JA} , and T_A . The maximum allowable power dissipation at any allowable ambient temperature is $P_D = (T_{J(max)} - T_A)/\theta_{JA}$. Operating at the absolute maximum T_J of 150°C can affect reliability.
- (4) The package thermal impedance is calculated in accordance with JESD 51-7.
- (5) Maximum power dissipation is a function of $T_{J(max)}$, θ_{JC} , and T_C . The maximum allowable power dissipation at any allowable case temperature is $P_D = (T_{J(max)} - T_C)/\theta_{JC}$. Operating at the absolute maximum T_J of 150°C can affect reliability.
- (6) The package thermal impedance is calculated in accordance with MIL-STD-883.

Recommended Operating Conditions

		MIN	MAX	UNIT
V _{KA}	Cathode voltage	V _{I(ref)}	36	V
I _{KA}	Cathode current	1	100	mA
T _A	Operating free-air temperature	TL1431C	0	70
		TL1431Q	-40	125
		TL1431M	-55	125

Electrical Characteristics

at specified free-air temperature, I_{KA} = 10 mA (unless otherwise noted)

PARAMETER	TEST CONDITIONS	T _A ⁽¹⁾	TEST CIRCUIT	TL1431C			UNIT	
				MIN	TYP	MAX		
V _{I(ref)}	Reference input voltage	V _{KA} = V _{I(ref)}	25°C	Figure 1	2490	2500	2510	mV
		Full range			2480		2520	
V _{I(dev)}	Deviation of reference input voltage over full temperature range ⁽²⁾	V _{KA} = V _{I(ref)}	Full range	Figure 1		4	20	mV
$\frac{\Delta V_{I(ref)}}{\Delta V_{KA}}$	Ratio of change in reference input voltage to the change in cathode voltage	ΔV _{KA} = 3 V to 36 V	Full range	Figure 2		-1.1	-2	mV/V
I _{I(ref)}	Reference input current	R1 = 10 kΩ, R2 = ∞	25°C	Figure 2		1.5	2.5	μA
			Full range					
I _{I(dev)}	Deviation of reference input current over full temperature range ⁽²⁾	R1 = 10 kΩ, R2 = ∞	Full range	Figure 2		0.2	1.2	μA
I _{min}	Minimum cathode current for regulation	V _{KA} = V _{I(ref)}	25°C	Figure 1		0.45	1	mA
I _{off}	Off-state cathode current	V _{KA} = 36 V, V _{I(ref)} = 0	25°C	Figure 3		0.18	0.5	μA
			Full range					
z _{KA}	Output impedance ⁽³⁾	V _{KA} = V _{I(ref)} , f ≤ 1 kHz, I _{KA} = 1 mA to 100 mA	25°C	Figure 1		0.2	0.4	Ω

(1) Full range is 0°C to 70°C for C-suffix devices.

(2) The deviation parameters V_{I(dev)} and I_{I(dev)} are defined as the differences between the maximum and minimum values obtained over the rated temperature range. The average full-range temperature coefficient of the reference input voltage α_{V_{I(ref)}} is defined as:

$$\left| \alpha_{V_{I(ref)}} \right| \left(\frac{\text{ppm}}{^{\circ}\text{C}} \right) = \frac{\left(\frac{V_{I(dev)}}{V_{I(ref)} \text{ at } 25^{\circ}\text{C}} \right) \times 10^6}{T_A}$$

where:

ΔT_A is the rated operating temperature range of the device.

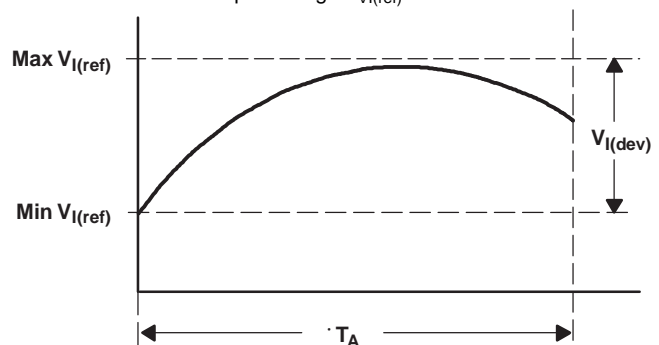

α_{V_{I(ref)}} is positive or negative, depending on whether minimum V_{I(ref)} or maximum V_{I(ref)}, respectively, occurs at the lower temperature.

(3) The output impedance is defined as: $|z_{KA}| = \frac{\Delta V_{KA}}{\Delta I_{KA}}$

When the device is operating with two external resistors (see Figure 2), the total dynamic impedance of the circuit is given by: $|z'| = \frac{\Delta V}{\Delta I}$,

which is approximately equal to $|z_{KA}| \left(1 + \frac{R1}{R2} \right)$.

Electrical Characteristics

at specified free-air temperature, $I_{KA} = 10 \text{ mA}$ (unless otherwise noted)

PARAMETER	TEST CONDITIONS	T_A ⁽¹⁾	TEST CIRCUIT	TL1431Q			TL1431M			UNIT
				MIN	TYP	MAX	MIN	TYP	MAX	
$V_{I(\text{ref})}$	Reference input voltage	$V_{KA} = V_{I(\text{ref})}$	Figure 1	2490	2500	2510	2475	2500	2540	mV
				Full range		2470	2530	2460	2550	
$V_{I(\text{dev})}$	Deviation of reference input voltage over full temperature range ⁽²⁾	$V_{KA} = V_{I(\text{ref})}$	Figure 1	17 55			17 55 ⁽³⁾		mV	
$\frac{\Delta V_{I(\text{ref})}}{\Delta V_{KA}}$	Ratio of change in reference input voltage to the change in cathode voltage	$\Delta V_{KA} = 3 \text{ V to } 36 \text{ V}$	Figure 2	-1.1 -2			-1.1 -2		mV/V	
$I_{I(\text{ref})}$	Reference input current	$R1 = 10 \text{ k}\Omega, R2 = \infty$	Figure 2	25°C	1.5	2.5	1.5	2.5	μA	
				Full range	4			5		
$I_{I(\text{dev})}$	Deviation of reference input current over full temperature range ⁽²⁾	$R1 = 10 \text{ k}\Omega, R2 = \infty$	Figure 2	0.5 2			0.5 3 ⁽³⁾		μA	
I_{min}	Minimum cathode current for regulation	$V_{KA} = V_{I(\text{ref})}$	Figure 1	0.45	1	0.45	1	mA		
I_{off}	Off-state cathode current	$V_{KA} = 36 \text{ V}, V_{I(\text{ref})} = 0$	Figure 3	25°C	0.18	0.5	0.18	0.5	μA	
				Full range	2			2		
$ z_{KA} $	Output impedance ⁽⁴⁾	$V_{KA} = V_{I(\text{ref})}, f \leq 1 \text{ kHz}, I_{KA} = 1 \text{ mA to } 100 \text{ mA}$	Figure 1	0.2	0.4	0.2	0.4	Ω		

(1) Full range is -40°C to 125°C for Q-suffix devices and -55°C to 125°C for M-suffix devices.

(2) The deviation parameters $V_{I(\text{dev})}$ and $I_{I(\text{dev})}$ are defined as the differences between the maximum and minimum values obtained over the rated temperature range. The average full-range temperature coefficient of the reference input voltage $\alpha_{V_{I(\text{ref})}}$ is defined as:

$$\left| \alpha_{V_{I(\text{ref})}} \right| \left(\frac{\text{ppm}}{^\circ\text{C}} \right) = \frac{\left(\frac{V_{I(\text{dev})}}{V_{I(\text{ref})} \text{ at } 25^\circ\text{C}} \right) \times 10^6}{T_A}$$

where:

ΔT_A is the rated operating temperature range of the device.

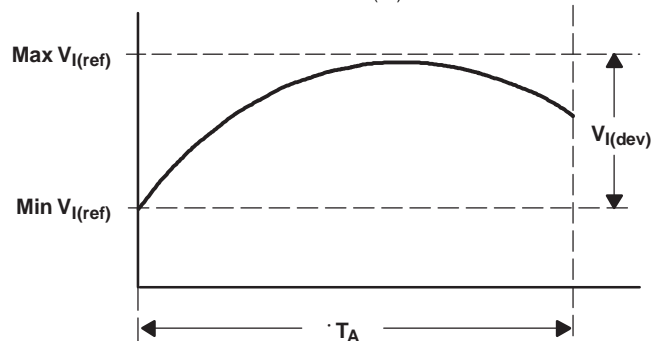

$\alpha_{V_{I(\text{ref})}}$ is positive or negative, depending on whether minimum $V_{I(\text{ref})}$ or maximum $V_{I(\text{ref})}$, respectively, occurs at the lower temperature.

(3) On products compliant to MIL-PRF-38535, this parameter is not production tested.

(4) The output impedance is defined as: $|z_{KA}| = \frac{\Delta V_{KA}}{\Delta I_{KA}}$

When the device is operating with two external resistors (see Figure 2), the total dynamic impedance of the circuit is given by: $|z'| = \frac{\Delta V}{\Delta I}$,

which is approximately equal to $|z_{KA}| \left(1 + \frac{R1}{R2} \right)$.

PARAMETER MEASUREMENT INFORMATION

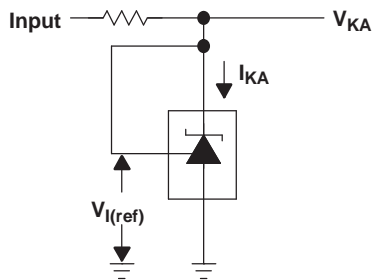

Figure 1. Test Circuit for $V_{(KA)} = V_{ref}$

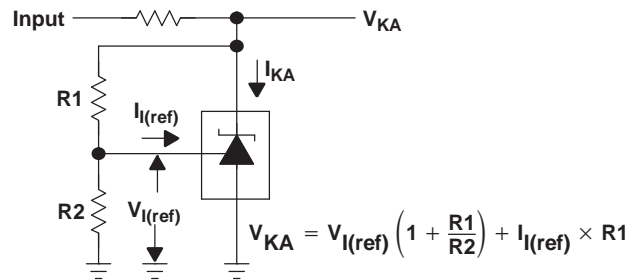

Figure 2. Test Circuit for $V_{(KA)} > V_{ref}$

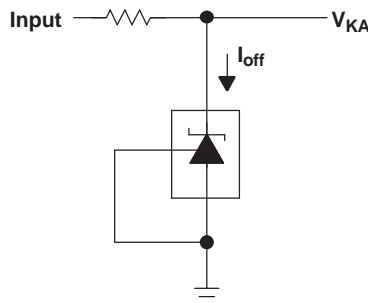

Figure 3. Test Circuit for I_{off}

TYPICAL CHARACTERISTICS

Data at high and low temperatures are applicable only within the recommended operating free-air temperature ranges of the various devices.

Table of Graphs

GRAPH	FIGURE
Reference voltage vs Free-air temperature	4
Reference current vs Free-air temperature	5
Cathode current vs Cathode voltage	6, 7
Off-state cathode current vs Free-air temperature	8
Ratio of delta reference voltage to delta cathode voltage vs Free-air temperature	9
Equivalent input-noise voltage vs Frequency	10
Equivalent input-noise voltage over a 10-second period	11
Small-signal voltage amplification vs Frequency	12
Reference impedance vs Frequency	13
Pulse response	14
Stability boundary conditions	15

REFERENCE VOLTAGE
VS
FREE-AIR TEMPERATURE

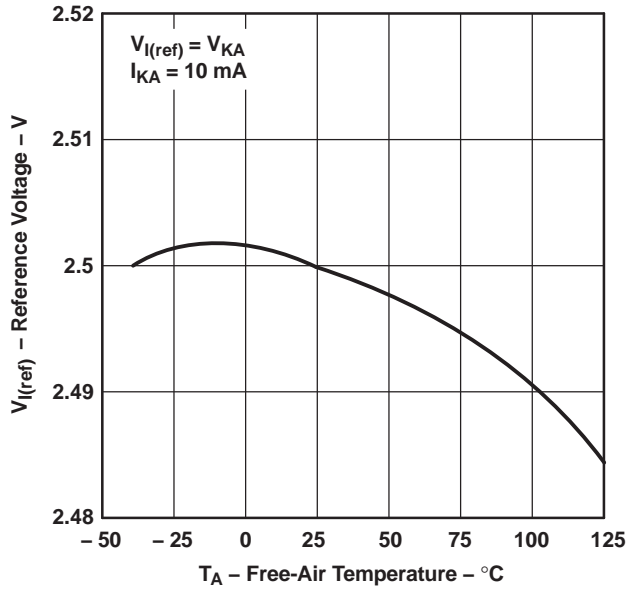

Figure 4.

REFERENCE CURRENT
VS
FREE-AIR TEMPERATURE

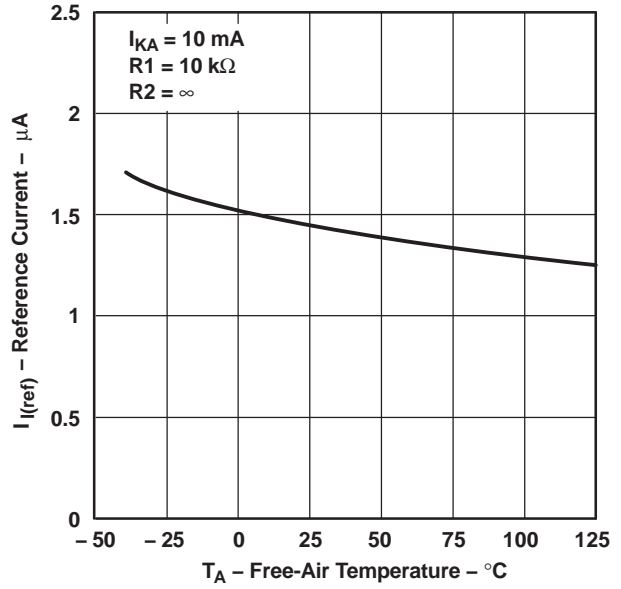

Figure 5.

CATHODE CURRENT
VS
CATHODE VOLTAGE

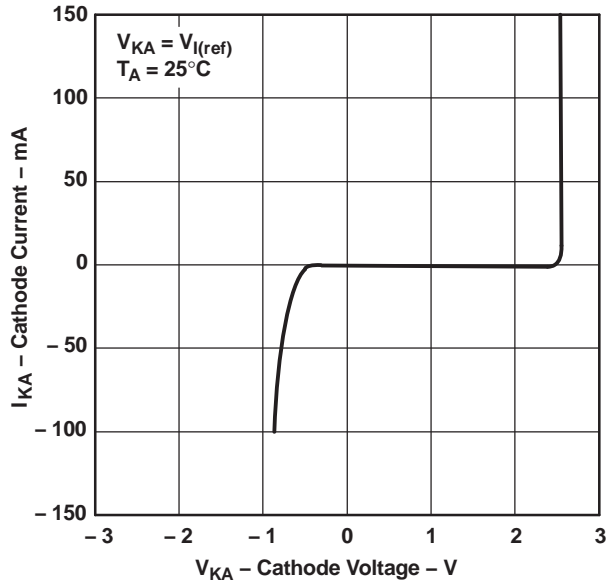

Figure 6.

CATHODE CURRENT
VS
CATHODE VOLTAGE

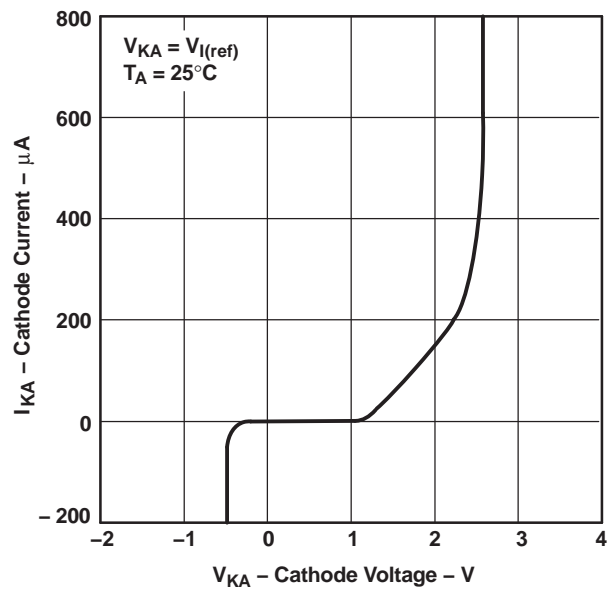

Figure 7.

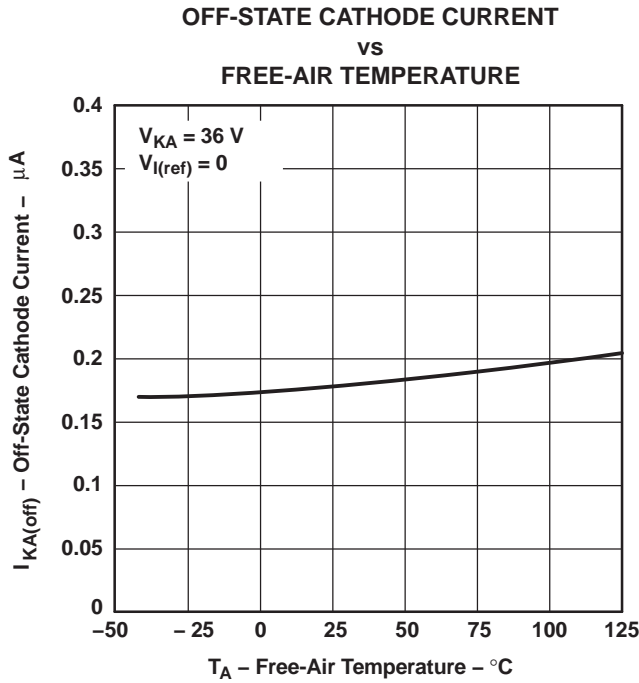

Figure 8.

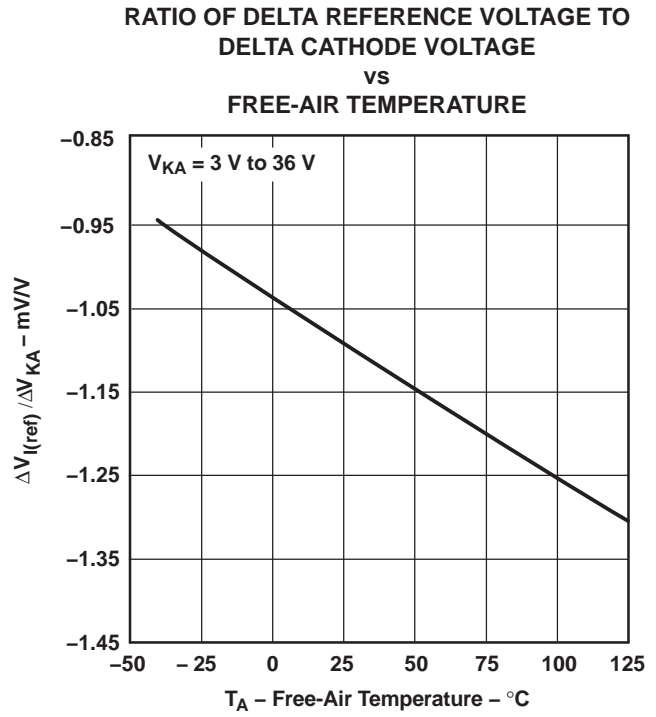

Figure 9.

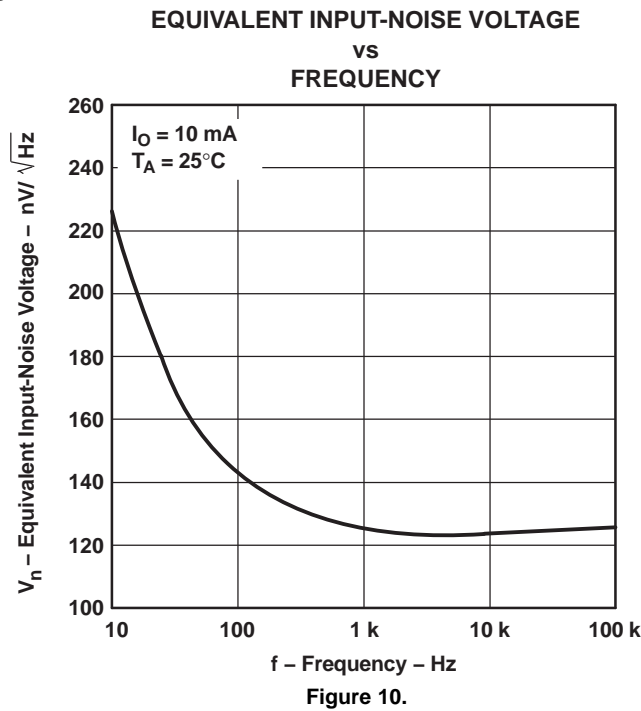
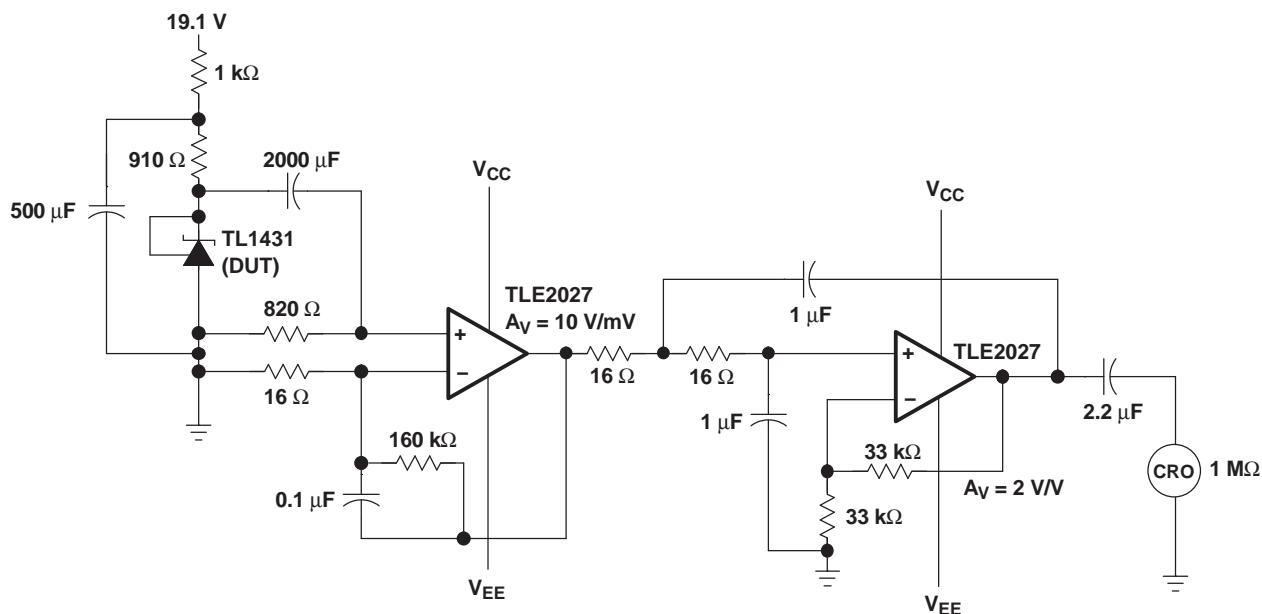
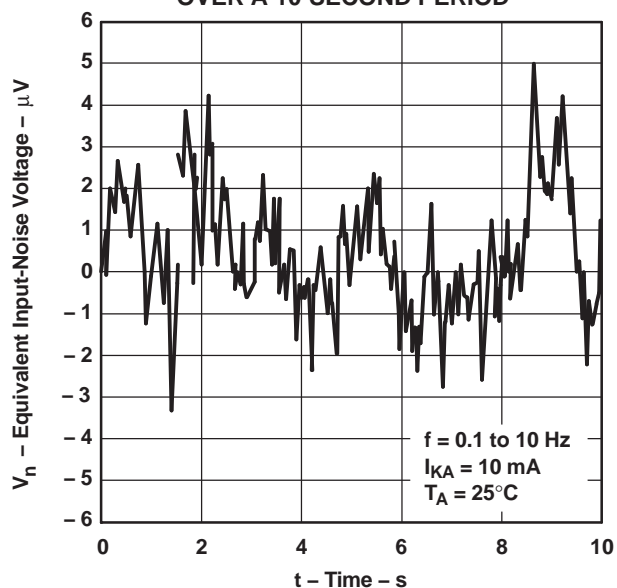
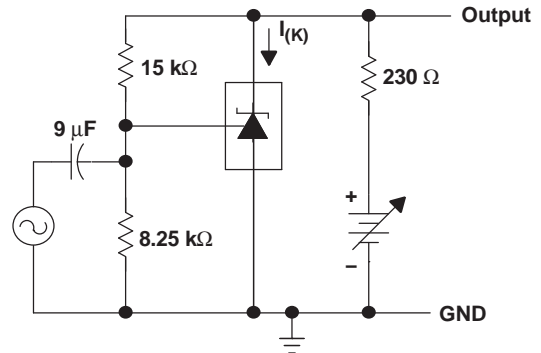
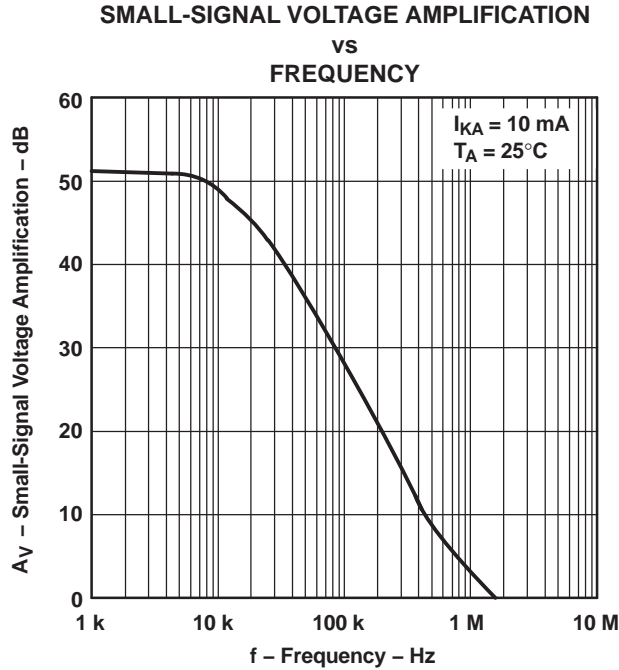

Figure 10.

EQUIVALENT INPUT-NOISE VOLTAGE
OVER A 10-SECOND PERIOD



TEST CIRCUIT FOR 0.1-Hz TO 10-Hz EQUIVALENT INPUT-NOISE VOLTAGE
Figure 11.



TEST CIRCUIT FOR VOLTAGE AMPLIFICATION

Figure 12.

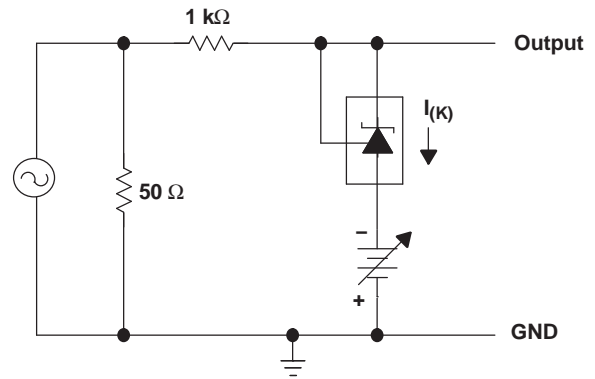
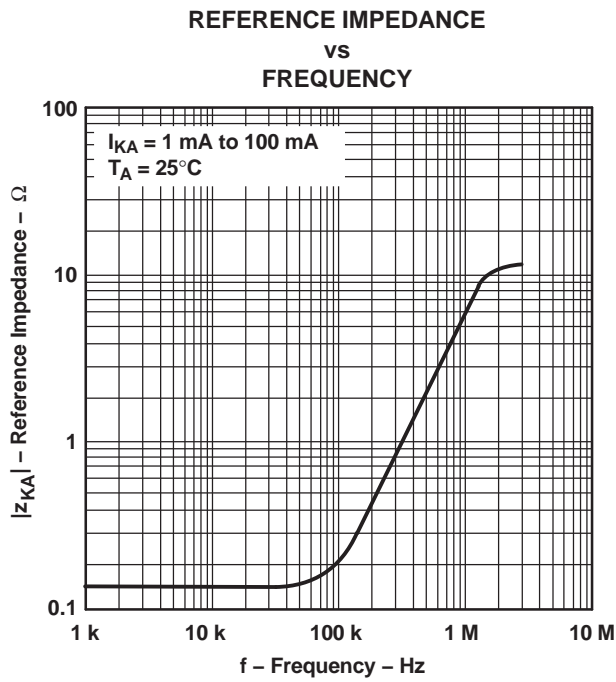

TEST CIRCUIT FOR REFERENCE IMPEDANCE

Figure 13.

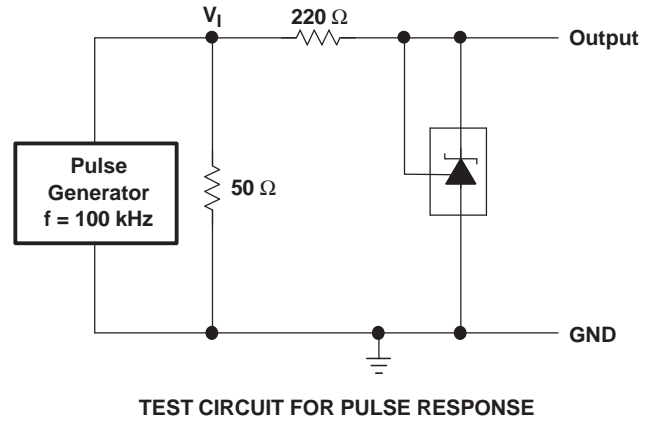
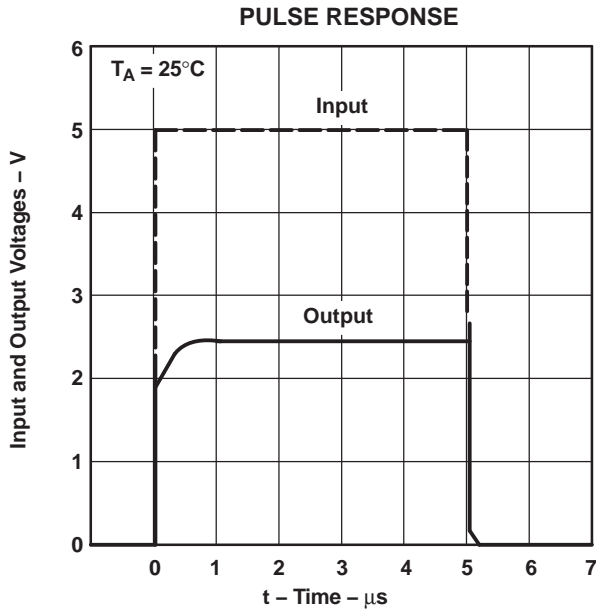
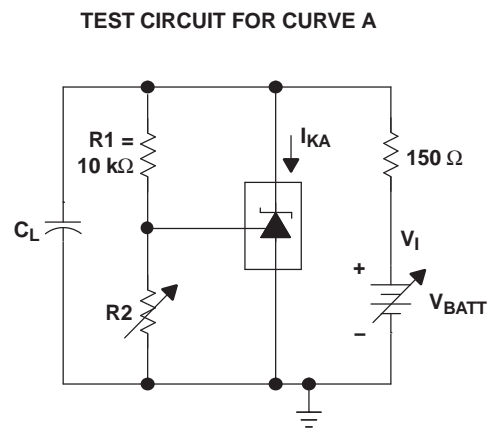
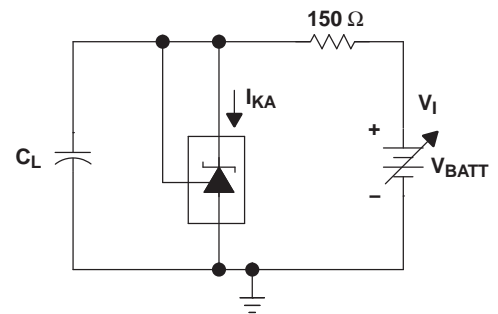
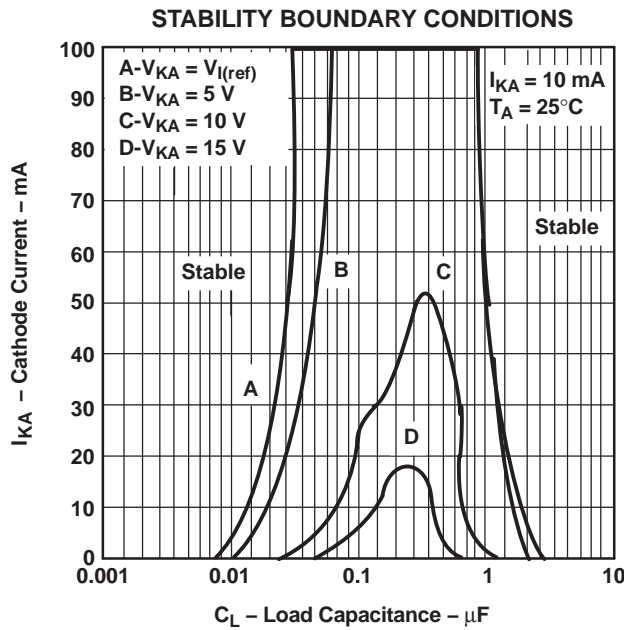

Figure 14.



- A. The areas under the curves represent conditions that may cause the device to oscillate. For curves B, C, and D, R_2 and V_+ are adjusted to establish the initial V_{KA} and I_{KA} conditions, with $C_L = 0$. V_{BATT} and C_L then are adjusted to determine the ranges of stability.

Figure 15.

APPLICATION INFORMATION

Table of Application Circuits

APPLICATION	FIGURE
Shunt regulator	16
Single-supply comparator with temperature-compensated threshold	17
Precision high-current series regulator	18
Output control of a three-terminal fixed regulator	19
Higher-current shunt regulator	20
Crowbar	21
Precision 5-V, 1.5-A, 0.5% regulator	22
5-V precision regulator	23
PWM converter with 0.5% reference	24
Voltage monitor	25
Delay timer	26
Precision current limiter	27
Precision constant-current sink	28

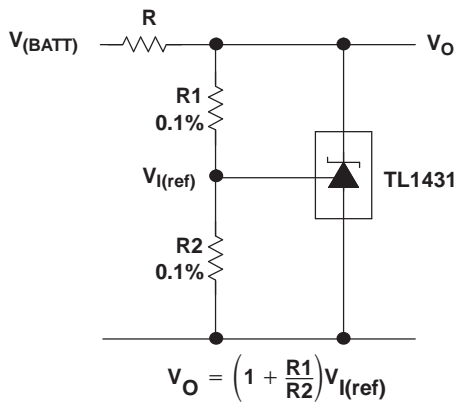

A. R should provide cathode current ≥ 1 mA to the TL1431 at minimum $V_{(BATT)}$.
Figure 16. Shunt Regulator

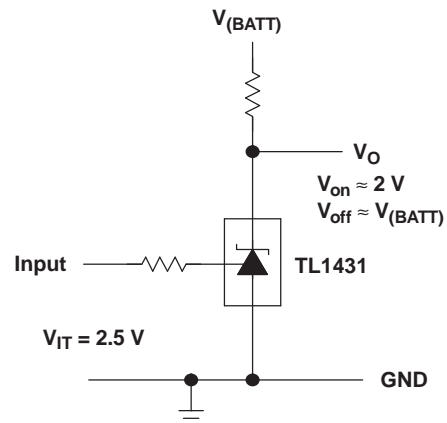
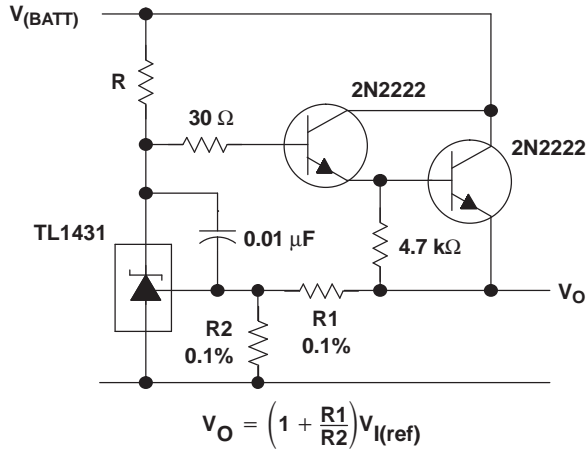

Figure 17. Single-Supply Comparator With Temperature-Compensated Threshold



A. R should provide cathode current ≥ 1 mA to the TL1431 at minimum $V_{(\text{BATT})}$.
Figure 18. Precision High-Current Series Regulator

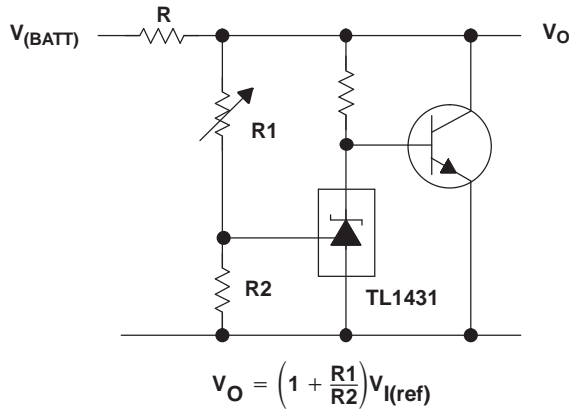

Figure 20. Higher-Current Shunt Regulator

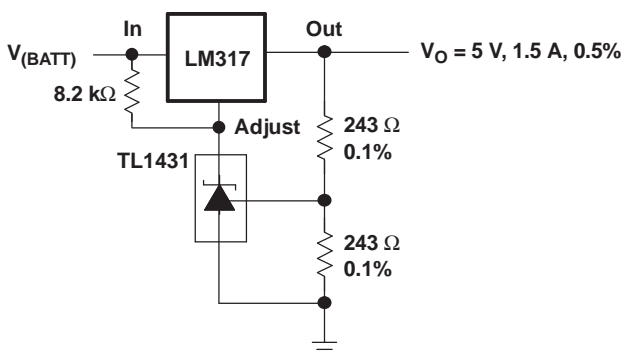

Figure 22. Precision 5-V, 1.5-A, 0.5% Regulator

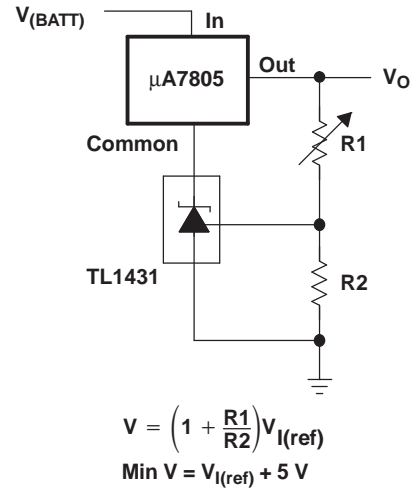
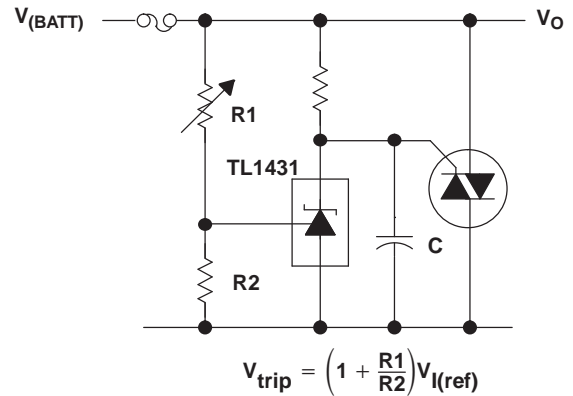
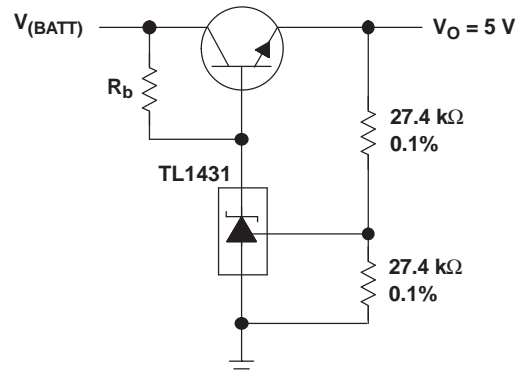

Figure 19. Output Control of a Three-Terminal Fixed Regulator



A. Refer to the stability boundary conditions in Figure 15 to determine allowable values for C.

Figure 21. Crowbar



A. R_b should provide cathode current ≥ 1 mA to the TL1431.

Figure 23. 5-V Precision Regulator

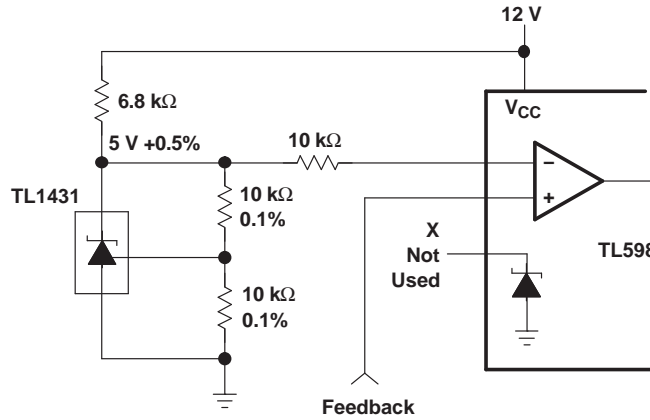
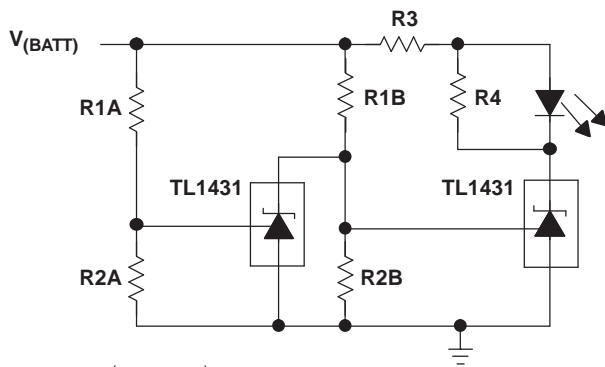

Figure 24. PWM Converter With 0.5% Reference



$$\text{Low Limit} = \left(1 + \frac{R1B}{R2B}\right) V_{I(\text{ref})}$$

$$\text{High Limit} = \left(1 + \frac{R1A}{R2A}\right) V_{I(\text{ref})}$$

LED on When
 Low Limit < V_(BATT) < High Limit

- A. Select R3 and R4 to provide the desired LED intensity and cathode current ≥1 mA to the TL1431.

Figure 25. Voltage Monitor

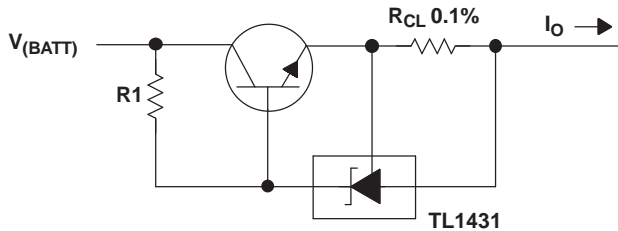

$$I_O = \frac{V_{I(\text{ref})}}{R_{CL}} + I_{KA}$$

$$R1 = \frac{V_{(BATT)}}{\left(\frac{I_O}{h_{FE}}\right) + I_{KA}}$$

Figure 27. Precision Current Limiter

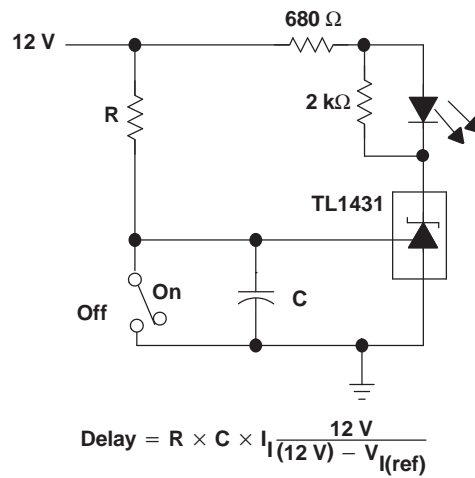

$$\text{Delay} = R \times C \times I_{(12V)} \frac{12V}{12V - V_{I(\text{ref})}}$$

Figure 26. Delay Timer

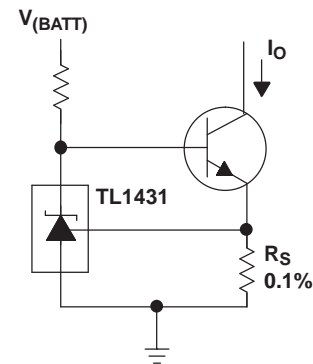

$$I_O = \frac{V_{I(\text{ref})}}{R_S}$$

Figure 28. Precision Constant-Current Sink

PACKAGING INFORMATION

Orderable Device	Status ⁽¹⁾	Package Type	Package Drawing	Pins	Package Qty	Eco Plan ⁽²⁾	Lead/ Ball Finish	MSL Peak Temp ⁽³⁾	Samples (Requires Login)
5962-9962001Q2A	ACTIVE	LCCC	FK	20	1	TBD	POST-PLATE	N / A for Pkg Type	Purchase Samples
5962-9962001QPA	ACTIVE	CDIP	JG	8	1	TBD	A42	N / A for Pkg Type	Purchase Samples
5962-9962001VPA	ACTIVE	CDIP	JG	8	1	TBD	A42	N / A for Pkg Type	Purchase Samples
TL1431CD	ACTIVE	SOIC	D	8	75	Green (RoHS & no Sb/Br)	CU NIPDAU	Level-1-260C-UNLIM	Purchase Samples
TL1431CDE4	ACTIVE	SOIC	D	8	75	Green (RoHS & no Sb/Br)	CU NIPDAU	Level-1-260C-UNLIM	Purchase Samples
TL1431CDG4	ACTIVE	SOIC	D	8	75	Green (RoHS & no Sb/Br)	CU NIPDAU	Level-1-260C-UNLIM	Purchase Samples
TL1431CDR	ACTIVE	SOIC	D	8	2500	Green (RoHS & no Sb/Br)	CU NIPDAU	Level-1-260C-UNLIM	Contact TI Distributor or Sales Office
TL1431CDRE4	ACTIVE	SOIC	D	8	2500	Green (RoHS & no Sb/Br)	CU NIPDAU	Level-1-260C-UNLIM	Contact TI Distributor or Sales Office
TL1431CDRG4	ACTIVE	SOIC	D	8	2500	Green (RoHS & no Sb/Br)	CU NIPDAU	Level-1-260C-UNLIM	Contact TI Distributor or Sales Office
TL1431CKTPR	OBSOLETE	PFM	KTP	2		TBD	Call TI	Call TI	Samples Not Available
TL1431CLP	ACTIVE	TO-92	LP	3	1000	Pb-Free (RoHS)	CU SN	N / A for Pkg Type	Purchase Samples
TL1431CLPE3	ACTIVE	TO-92	LP	3	1000	Pb-Free (RoHS)	CU SN	N / A for Pkg Type	Purchase Samples
TL1431CLPM	OBSOLETE	TO-92	LP	3		TBD	Call TI	Call TI	Samples Not Available
TL1431CLPR	ACTIVE	TO-92	LP	3	2000	Pb-Free (RoHS)	CU SN	N / A for Pkg Type	Contact TI Distributor or Sales Office
TL1431CLPRE3	ACTIVE	TO-92	LP	3	2000	Pb-Free (RoHS)	CU SN	N / A for Pkg Type	Contact TI Distributor or Sales Office
TL1431CPW	ACTIVE	TSSOP	PW	8	150	Green (RoHS & no Sb/Br)	CU NIPDAU	Level-1-260C-UNLIM	Purchase Samples
TL1431CPWE4	ACTIVE	TSSOP	PW	8	150	Green (RoHS & no Sb/Br)	CU NIPDAU	Level-1-260C-UNLIM	Purchase Samples
TL1431CPWG4	ACTIVE	TSSOP	PW	8	150	Green (RoHS & no Sb/Br)	CU NIPDAU	Level-1-260C-UNLIM	Purchase Samples
TL1431CPWR	ACTIVE	TSSOP	PW	8	2000	Green (RoHS & no Sb/Br)	CU NIPDAU	Level-1-260C-UNLIM	Contact TI Distributor or Sales Office
TL1431CPWRE4	ACTIVE	TSSOP	PW	8	2000	Green (RoHS & no Sb/Br)	CU NIPDAU	Level-1-260C-UNLIM	Contact TI Distributor or Sales Office

Orderable Device	Status ⁽¹⁾	Package Type	Package Drawing	Pins	Package Qty	Eco Plan ⁽²⁾	Lead/ Ball Finish	MSL Peak Temp ⁽³⁾	Samples (Requires Login)
TL1431CPWRG4	ACTIVE	TSSOP	PW	8	2000	Green (RoHS & no Sb/Br)	CU NIPDAU	Level-1-260C-UNLIM	Contact TI Distributor or Sales Office
TL1431MFK	ACTIVE	LCCC	FK	20	1	TBD	POST-PLATE	N / A for Pkg Type	Purchase Samples
TL1431MFKB	ACTIVE	LCCC	FK	20	1	TBD	POST-PLATE	N / A for Pkg Type	Purchase Samples
TL1431MJG	ACTIVE	CDIP	JG	8	1	TBD	A42	N / A for Pkg Type	Purchase Samples
TL1431MJGB	ACTIVE	CDIP	JG	8	1	TBD	A42	N / A for Pkg Type	Purchase Samples
TL1431QD	ACTIVE	SOIC	D	8	75	Pb-Free (RoHS)	CU NIPDAU	Level-2-250C-1 YEAR/ Level-1-235C-UNLIM	Contact TI Distributor or Sales Office
TL1431QDG4	ACTIVE	SOIC	D	8	75	Green (RoHS & no Sb/Br)	CU NIPDAU	Level-1-260C-UNLIM	Request Free Samples
TL1431QDR	ACTIVE	SOIC	D	8	2500	Green (RoHS & no Sb/Br)	CU NIPDAU	Level-1-260C-UNLIM	Purchase Samples
TL1431QDRG4	ACTIVE	SOIC	D	8	2500	Green (RoHS & no Sb/Br)	CU NIPDAU	Level-1-260C-UNLIM	Purchase Samples
TL1431QLP	OBSOLETE	TO-92	LP	3		TBD	Call TI	Call TI	Samples Not Available
TL1431QLPR	OBSOLETE	TO-92	LP	3		TBD	Call TI	Call TI	Samples Not Available
TL1431QPWR	ACTIVE	TSSOP	PW	8	2000	TBD	CU NIPDAU	Level-1-250C-UNLIM	Purchase Samples
TL1431QPWRG4	ACTIVE	TSSOP	PW	8	2000	Green (RoHS & no Sb/Br)	CU NIPDAU	Level-1-260C-UNLIM	Purchase Samples

⁽¹⁾ The marketing status values are defined as follows:

ACTIVE: Product device recommended for new designs.

LIFEBUY: TI has announced that the device will be discontinued, and a lifetime-buy period is in effect.

NRND: Not recommended for new designs. Device is in production to support existing customers, but TI does not recommend using this part in a new design.

PREVIEW: Device has been announced but is not in production. Samples may or may not be available.

OBSOLETE: TI has discontinued the production of the device.

⁽²⁾ Eco Plan - The planned eco-friendly classification: Pb-Free (RoHS), Pb-Free (RoHS Exempt), or Green (RoHS & no Sb/Br) - please check <http://www.ti.com/productcontent> for the latest availability information and additional product content details.

TBD: The Pb-Free/Green conversion plan has not been defined.

Pb-Free (RoHS): TI's terms "Lead-Free" or "Pb-Free" mean semiconductor products that are compatible with the current RoHS requirements for all 6 substances, including the requirement that lead not exceed 0.1% by weight in homogeneous materials. Where designed to be soldered at high temperatures, TI Pb-Free products are suitable for use in specified lead-free processes.

Pb-Free (RoHS Exempt): This component has a RoHS exemption for either 1) lead-based flip-chip solder bumps used between the die and package, or 2) lead-based die adhesive used between the die and leadframe. The component is otherwise considered Pb-Free (RoHS compatible) as defined above.

Green (RoHS & no Sb/Br): TI defines "Green" to mean Pb-Free (RoHS compatible), and free of Bromine (Br) and Antimony (Sb) based flame retardants (Br or Sb do not exceed 0.1% by weight in homogeneous material)

⁽³⁾ MSL, Peak Temp. -- The Moisture Sensitivity Level rating according to the JEDEC industry standard classifications, and peak solder temperature.

Important Information and Disclaimer: The information provided on this page represents TI's knowledge and belief as of the date that it is provided. TI bases its knowledge and belief on information provided by third parties, and makes no representation or warranty as to the accuracy of such information. Efforts are underway to better integrate information from third parties. TI has taken and continues to take reasonable steps to provide representative and accurate information but may not have conducted destructive testing or chemical analysis on incoming materials and chemicals. TI and TI suppliers consider certain information to be proprietary, and thus CAS numbers and other limited information may not be available for release.

In no event shall TI's liability arising out of such information exceed the total purchase price of the TI part(s) at issue in this document sold by TI to Customer on an annual basis.

OTHER QUALIFIED VERSIONS OF TL1431, TL1431-SP, TL1431M :

- Catalog: [TL1431](#), [TL1431](#)
- Automotive: [TL1431-Q1](#), [TL1431-Q1](#), [TL1431-Q1](#)
- Enhanced Product: [TL1431-EP](#), [TL1431-EP](#), [TL1431-EP](#)
- Military: [TL1431M](#), [TL1431M](#)
- Space: [TL1431-SP](#), [TL1431-SP](#)

NOTE: Qualified Version Definitions:

- Catalog - TI's standard catalog product
- Automotive - Q100 devices qualified for high-reliability automotive applications targeting zero defects
- Enhanced Product - Supports Defense, Aerospace and Medical Applications
- Military - QML certified for Military and Defense Applications
- Space - Radiation tolerant, ceramic packaging and qualified for use in Space-based application

TAPE AND REEL INFORMATION



QUADRANT ASSIGNMENTS FOR PIN 1 ORIENTATION IN TAPE



*All dimensions are nominal

Device	Package Type	Package Drawing	Pins	SPQ	Reel Diameter (mm)	Reel Width W1 (mm)	A0 (mm)	B0 (mm)	K0 (mm)	P1 (mm)	W (mm)	Pin1 Quadrant
TL1431CDR	SOIC	D	8	2500	330.0	12.4	6.4	5.2	2.1	8.0	12.0	Q1
TL1431CPWR	TSSOP	PW	8	2000	330.0	12.4	7.0	3.6	1.6	8.0	12.0	Q1
TL1431QPWR	TSSOP	PW	8	2000	330.0	12.4	7.0	3.6	1.6	8.0	12.0	Q1

TAPE AND REEL BOX DIMENSIONS

*All dimensions are nominal

Device	Package Type	Package Drawing	Pins	SPQ	Length (mm)	Width (mm)	Height (mm)
TL1431CDR	SOIC	D	8	2500	340.5	338.1	20.6
TL1431CPWR	TSSOP	PW	8	2000	346.0	346.0	29.0
TL1431QPWR	TSSOP	PW	8	2000	346.0	346.0	29.0

JG (R-GDIP-T8)

CERAMIC DUAL-IN-LINE

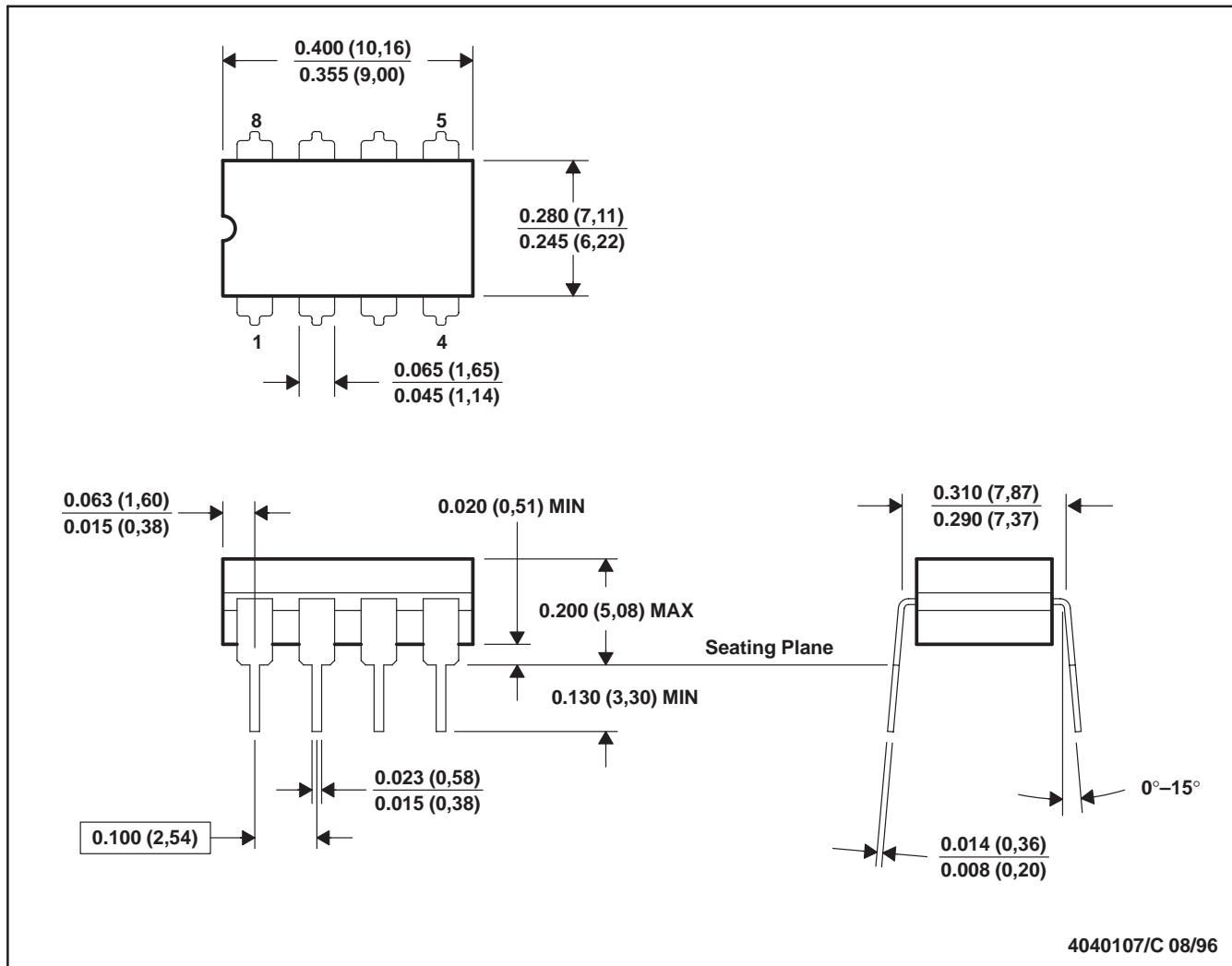

- NOTES: A. All linear dimensions are in inches (millimeters).
 B. This drawing is subject to change without notice.
 C. This package can be hermetically sealed with a ceramic lid using glass frit.
 D. Index point is provided on cap for terminal identification.
 E. Falls within MIL STD 1835 GDIP1-T8

FK (S-CQCC-N**)

LEADLESS CERAMIC CHIP CARRIER

28 TERMINAL SHOWN



- NOTES:
- A. All linear dimensions are in inches (millimeters).
 - B. This drawing is subject to change without notice.
 - C. This package can be hermetically sealed with a metal lid.
 - D. The terminals are gold plated.
 - E. Falls within JEDEC MS-004

KTP (R-PSFM-G2)

PowerFLEX™ PLASTIC FLANGE-MOUNT PACKAGE

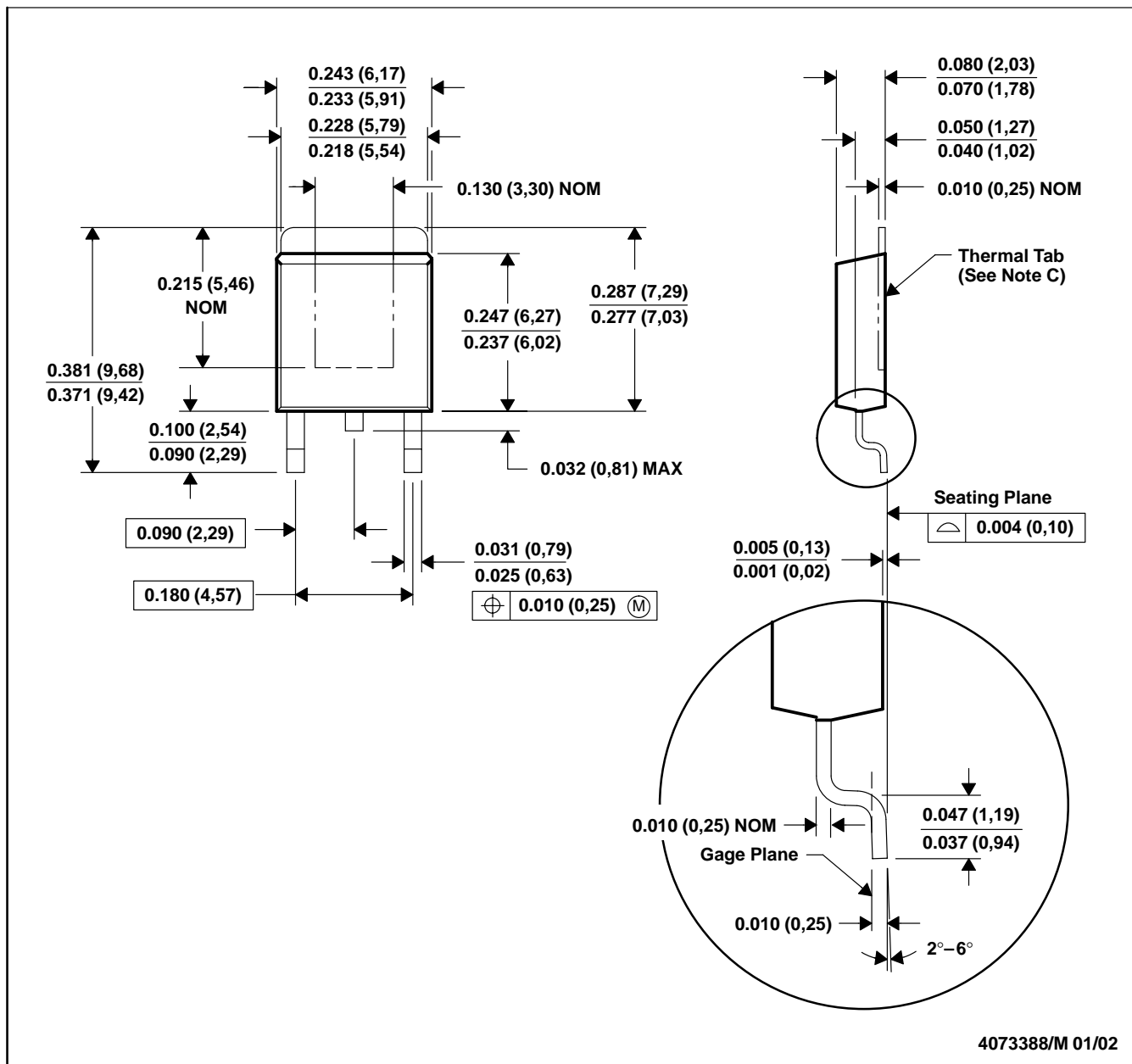

- NOTES: A. All linear dimensions are in inches (millimeters).
 B. This drawing is subject to change without notice.
 C. The center lead is in electrical contact with the thermal tab.
 D. Dimensions do not include mold protrusions, not to exceed 0.006 (0,15).
 E. Falls within JEDEC TO-252 variation AC.

PowerFLEX is a trademark of Texas Instruments.

D (R-PDSO-G8)

PLASTIC SMALL-OUTLINE PACKAGE

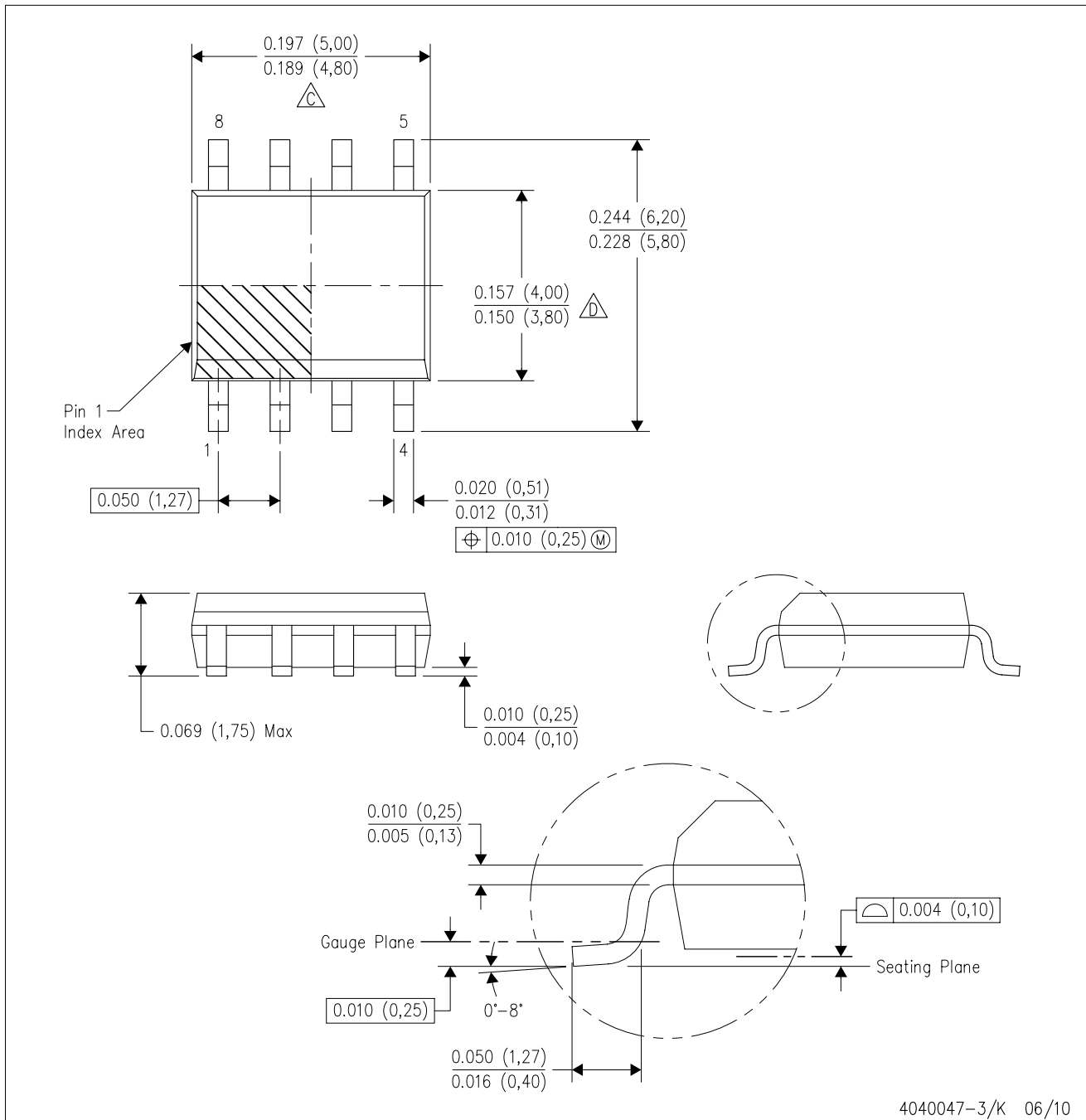

- NOTES:
- A. All linear dimensions are in inches (millimeters).
 - B. This drawing is subject to change without notice.
 - C. Body length does not include mold flash, protrusions, or gate burrs. Mold flash, protrusions, or gate burrs shall not exceed .006 (0,15) per end.
 - D. Body width does not include interlead flash. Interlead flash shall not exceed .017 (0,43) per side.
 - E. Reference JEDEC MS-012 variation AA.

D (R-PDSO-G8)

PLASTIC SMALL OUTLINE

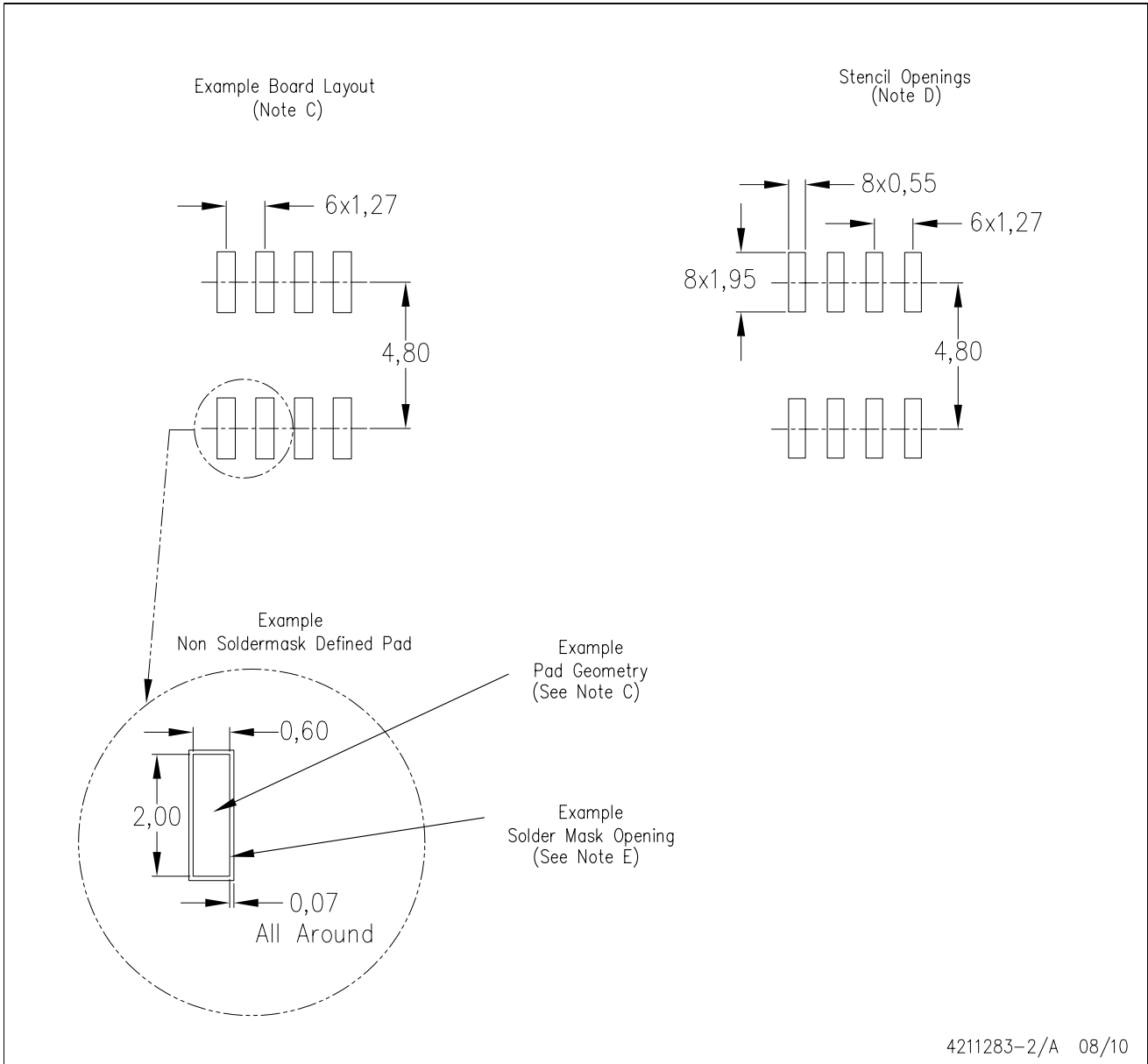

4211283-2/A 08/10

- NOTES:
- A. All linear dimensions are in millimeters.
 - B. This drawing is subject to change without notice.
 - C. Publication IPC-7351 is recommended for alternate designs.
 - D. Laser cutting apertures with trapezoidal walls and also rounding corners will offer better paste release. Customers should contact their board assembly site for stencil design recommendations. Refer to IPC-7525 for other stencil recommendations.
 - E. Customers should contact their board fabrication site for solder mask tolerances between and around signal pads.

LP (O-PBCY-W3)

PLASTIC CYLINDRICAL PACKAGE

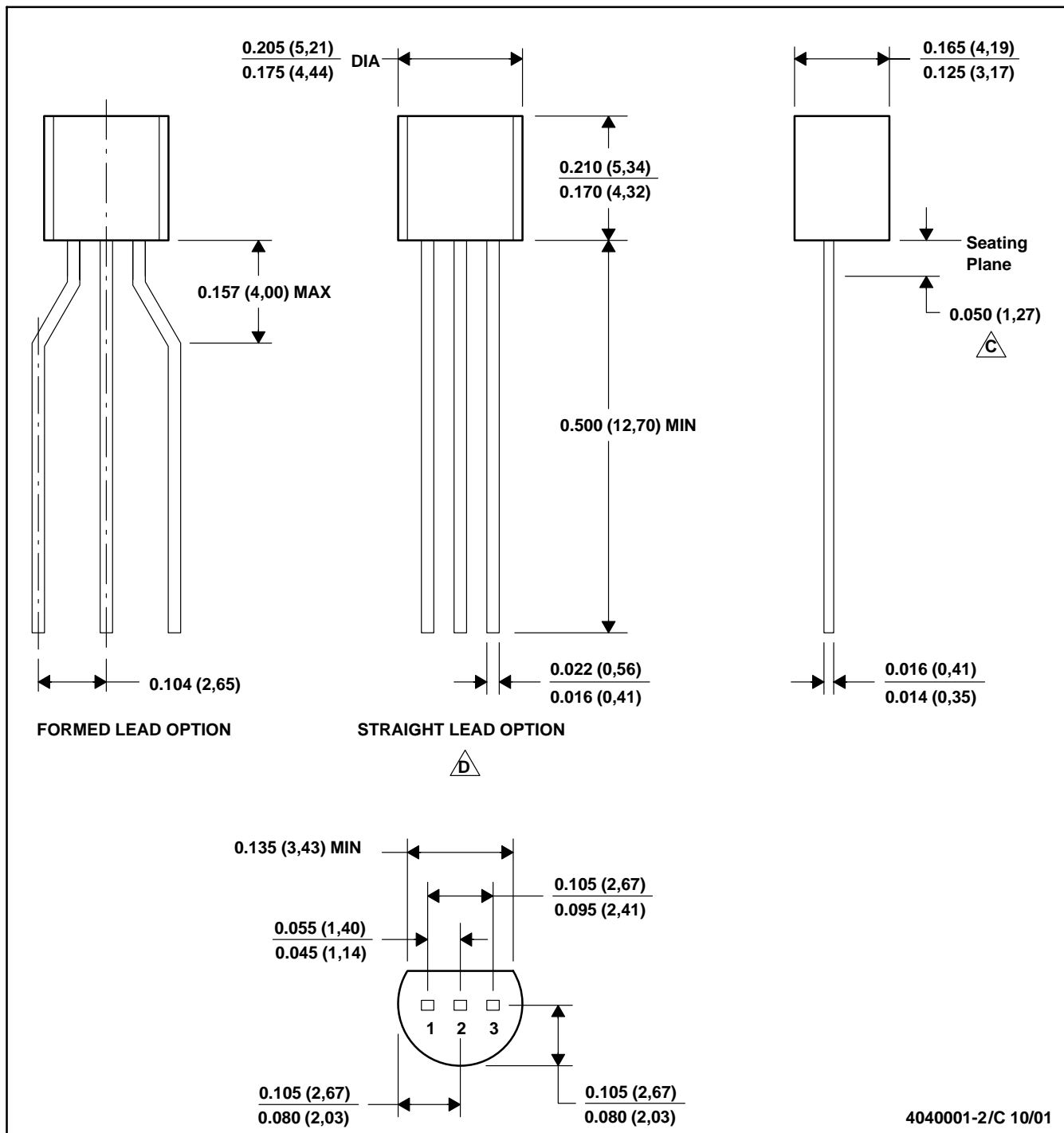

- NOTES: A. All linear dimensions are in inches (millimeters).
 B. This drawing is subject to change without notice.
 C. Lead dimensions are not controlled within this area
 D. Falls within JEDEC TO -226 Variation AA (TO-226 replaces TO-92)
 E. Shipping Method:
 Straight lead option available in bulk pack only.
 Formed lead option available in tape & reel or ammo pack.

MECHANICAL DATA

MSOT002A – OCTOBER 1994 – REVISED NOVEMBER 2001

LP (O-PBCY-W3)

PLASTIC CYLINDRICAL PACKAGE

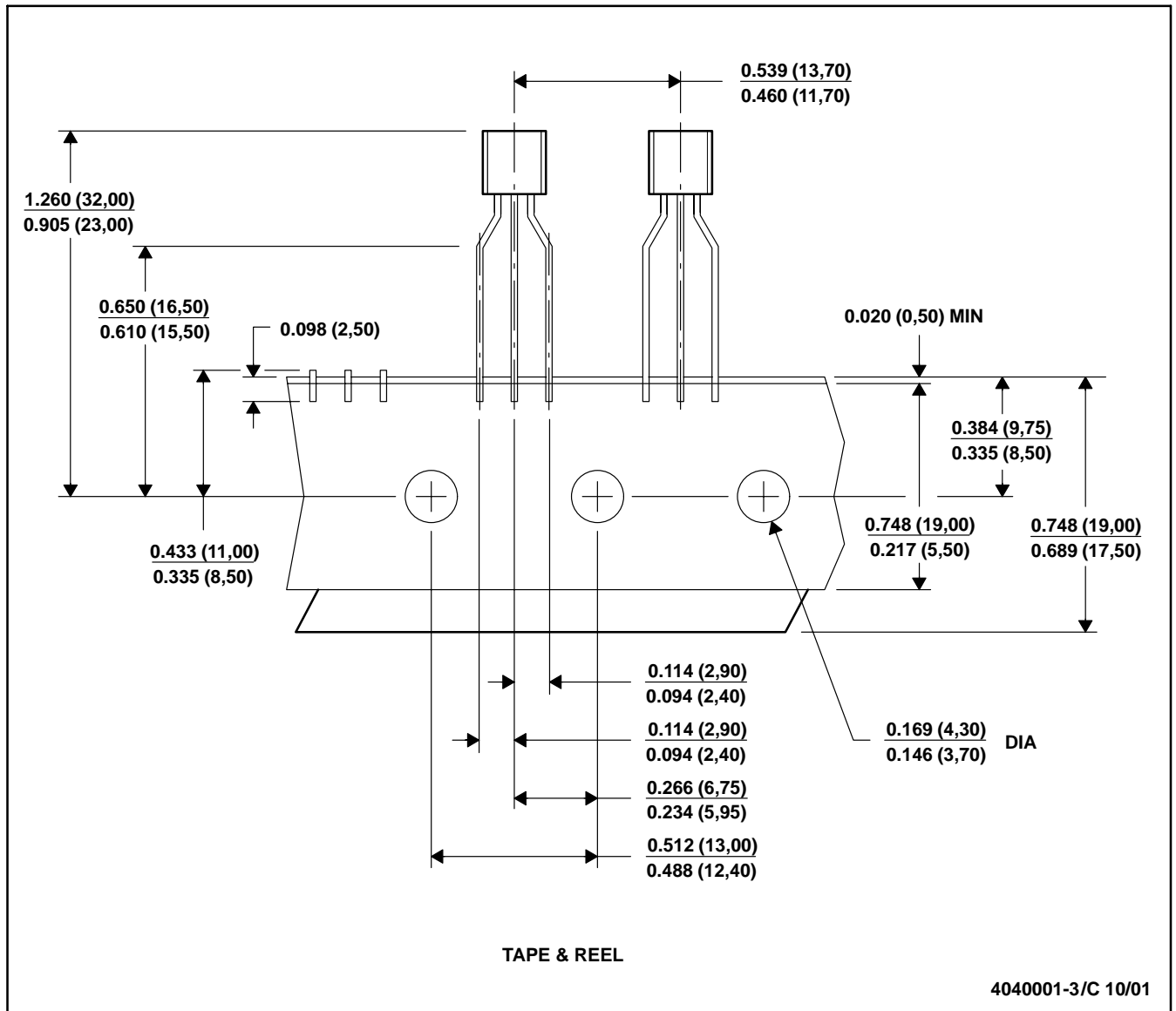

- NOTES: A. All linear dimensions are in inches (millimeters).
 B. This drawing is subject to change without notice.
 C. Tape and Reel information for the Format Lead Option package.

PW (R-PDSO-G**)

PLASTIC SMALL-OUTLINE PACKAGE

14 PINS SHOWN



4040064/F 01/97

- NOTES: A. All linear dimensions are in millimeters.
 B. This drawing is subject to change without notice.
 C. Body dimensions do not include mold flash or protrusion not to exceed 0,15.
 D. Falls within JEDEC MO-153

IMPORTANT NOTICE

Texas Instruments Incorporated and its subsidiaries (TI) reserve the right to make corrections, modifications, enhancements, improvements, and other changes to its products and services at any time and to discontinue any product or service without notice. Customers should obtain the latest relevant information before placing orders and should verify that such information is current and complete. All products are sold subject to TI's terms and conditions of sale supplied at the time of order acknowledgment.

TI warrants performance of its hardware products to the specifications applicable at the time of sale in accordance with TI's standard warranty. Testing and other quality control techniques are used to the extent TI deems necessary to support this warranty. Except where mandated by government requirements, testing of all parameters of each product is not necessarily performed.

TI assumes no liability for applications assistance or customer product design. Customers are responsible for their products and applications using TI components. To minimize the risks associated with customer products and applications, customers should provide adequate design and operating safeguards.

TI does not warrant or represent that any license, either express or implied, is granted under any TI patent right, copyright, mask work right, or other TI intellectual property right relating to any combination, machine, or process in which TI products or services are used. Information published by TI regarding third-party products or services does not constitute a license from TI to use such products or services or a warranty or endorsement thereof. Use of such information may require a license from a third party under the patents or other intellectual property of the third party, or a license from TI under the patents or other intellectual property of TI.

Reproduction of TI information in TI data books or data sheets is permissible only if reproduction is without alteration and is accompanied by all associated warranties, conditions, limitations, and notices. Reproduction of this information with alteration is an unfair and deceptive business practice. TI is not responsible or liable for such altered documentation. Information of third parties may be subject to additional restrictions.

Resale of TI products or services with statements different from or beyond the parameters stated by TI for that product or service voids all express and any implied warranties for the associated TI product or service and is an unfair and deceptive business practice. TI is not responsible or liable for any such statements.

TI products are not authorized for use in safety-critical applications (such as life support) where a failure of the TI product would reasonably be expected to cause severe personal injury or death, unless officers of the parties have executed an agreement specifically governing such use. Buyers represent that they have all necessary expertise in the safety and regulatory ramifications of their applications, and acknowledge and agree that they are solely responsible for all legal, regulatory and safety-related requirements concerning their products and any use of TI products in such safety-critical applications, notwithstanding any applications-related information or support that may be provided by TI. Further, Buyers must fully indemnify TI and its representatives against any damages arising out of the use of TI products in such safety-critical applications.

TI products are neither designed nor intended for use in military/aerospace applications or environments unless the TI products are specifically designated by TI as military-grade or "enhanced plastic." Only products designated by TI as military-grade meet military specifications. Buyers acknowledge and agree that any such use of TI products which TI has not designated as military-grade is solely at the Buyer's risk, and that they are solely responsible for compliance with all legal and regulatory requirements in connection with such use.

TI products are neither designed nor intended for use in automotive applications or environments unless the specific TI products are designated by TI as compliant with ISO/TS 16949 requirements. Buyers acknowledge and agree that, if they use any non-designated products in automotive applications, TI will not be responsible for any failure to meet such requirements.

Following are URLs where you can obtain information on other Texas Instruments products and application solutions:

Products		Applications	
Amplifiers	amplifier.ti.com	Audio	www.ti.com/audio
Data Converters	dataconverter.ti.com	Automotive	www.ti.com/automotive
DLP® Products	www.dlp.com	Communications and Telecom	www.ti.com/communications
DSP	dsp.ti.com	Computers and Peripherals	www.ti.com/computers
Clocks and Timers	www.ti.com/clocks	Consumer Electronics	www.ti.com/consumer-apps
Interface	interface.ti.com	Energy	www.ti.com/energy
Logic	logic.ti.com	Industrial	www.ti.com/industrial
Power Mgmt	power.ti.com	Medical	www.ti.com/medical
Microcontrollers	microcontroller.ti.com	Security	www.ti.com/security
RFID	www.ti-rfid.com	Space, Avionics & Defense	www.ti.com/space-avionics-defense
RF/IF and ZigBee® Solutions	www.ti.com/lprf	Video and Imaging	www.ti.com/video
		Wireless	www.ti.com/wireless-apps