

TJA1043

High-speed CAN transceiver

Rev. 3 — 24 April 2013

Product data sheet

1. General description

The TJA1043 is a high-speed CAN transceiver that provides an interface between a Controller Area Network (CAN) protocol controller and the physical two-wire CAN bus. The transceiver is designed for high-speed (up to 1 Mbit/s) CAN applications in the automotive industry, providing differential transmit and receive capability to (a microcontroller with) a CAN protocol controller.

The TJA1043 belongs to the third generation of high-speed CAN transceivers from NXP Semiconductors, offering significant improvements over first- and second-generation devices such as the TJA1041A. It offers improved ElectroMagnetic Compatibility (EMC) and ElectroMagnetic Discharge (ESD) performance, very low power consumption, and passive behavior when the supply voltage is turned off. Advanced features include:

- Low-power management controls the power supply throughout the node while supporting local and remote wake-up with wake-up source recognition
- Several protection and diagnostic functions including bus line short-circuit detection and battery connection detection
- Can be interfaced directly to microcontrollers with supply voltages from 3 V to 5 V

These features make the TJA1043 the ideal choice for high speed CAN networks containing nodes that need to be available all times, even when the internal V_{IO} and V_{CC} supplies are switched off.

2. Features and benefits

2.1 General

- Fully ISO 11898-2 and ISO 11898-5 compliant
- Suitable for 12 V and 24 V systems
- Low ElectroMagnetic Emission (EME) and high ElectroMagnetic Immunity (EMI)
- V_{IO} input allows for direct interfacing with 3 V and 5 V microcontrollers
- SPLIT voltage output for stabilizing the recessive bus level
- Listen-only mode for node diagnosis and failure containment
- Available in SO14 and HVSON14 packages
- Leadless HVSON14 package (3.0 mm × 4.5 mm) with improved Automated Optical Inspection (AOI) capability
- Dark green product (halogen free and Restriction of Hazardous Substances (RoHS) compliant)



2.2 Low-power management

- Very low current Standby and Sleep modes, with local and remote wake-up
- Capability to power down the entire node while supporting local, remote and host wake-up
- Wake-up source recognition
- Transceiver disengages from the bus (zero load) when V_{BAT} absent
- Functional behavior predictable under all supply conditions

2.3 Protection and diagnosis (detection and signalling)

- High ESD handling capability on the bus pins
- Bus pins and V_{BAT} protected against transients in automotive environments
- Transmit Data (TXD) dominant time-out function with diagnosis
- TXD-to-RXD short-circuit handler with diagnosis
- Thermal protection with diagnosis
- Undervoltage detection and recovery on pins V_{CC} , V_{IO} and V_{BAT}
- Bus line short-circuit diagnosis
- Bus dominant clamping diagnosis
- Cold start diagnosis (first battery connection)

3. Quick reference data

Table 1. Quick reference data

Symbol	Parameter	Conditions	Min	Typ	Max	Unit
V_{CC}	supply voltage		4.5	-	5.5	V
$V_{uvd(VCC)}$	undervoltage detection voltage on pin V_{CC}		3	3.5	4.3	V
I_{CC}	supply current	Normal mode; bus dominant	30	48	65	mA
		Normal or Listen-only mode; bus recessive	3	6	9	mA
		Standby or Sleep mode	0	0.75	2	μ A
V_{ESD}	electrostatic discharge voltage	IEC 61000-4-2 at pins CANH and CANL	-8	-	+8	kV
V_{CANH}	voltage on pin CANH	no time limit; DC limiting value	-58	-	+58	V
V_{CANL}	voltage on pin CANL	no time limit; DC limiting value	-58	-	+58	V
T_{vj}	virtual junction temperature		-40	-	+150	$^{\circ}$ C

4. Ordering information

Table 2. Ordering information

Type number	Package		Version
	Name	Description	
TJA1043T	SO14	plastic small outline package; 14 leads; body width 3.9 mm	SOT108-1
TJA1043TK	HVSON14	plastic, thermal enhanced very thin small outline package; no leads; 14 terminals; body 3 × 4.5 × 0.85 mm	SOT1086-2

5. Block diagram

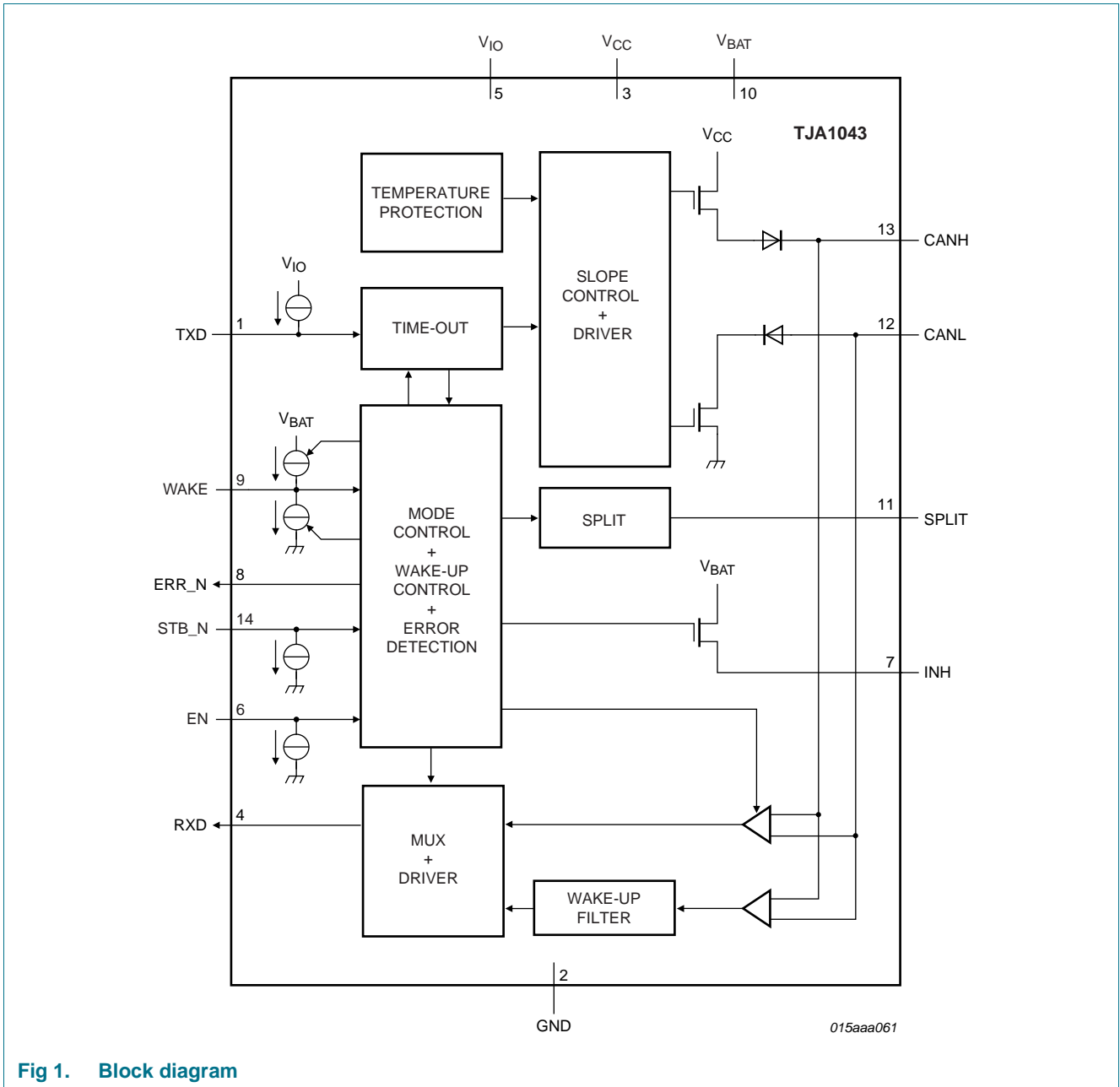
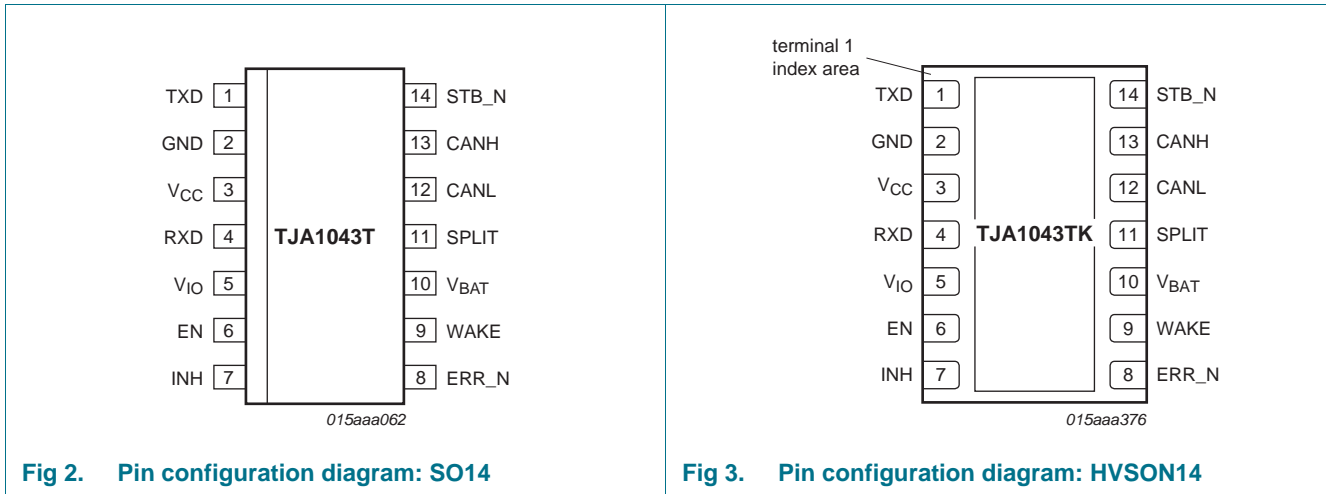

Fig 1. Block diagram

6. Pinning information

6.1 Pinning



6.2 Pin description

Table 3. Pin description

Symbol	Pin	Description
TXD	1	transmit data input
GND ^[1]	2	ground supply
V _{CC}	3	transceiver supply voltage
RXD	4	receive data output; reads out data from the bus lines
V _{IO}	5	supply voltage for I/O level adaptor
EN	6	enable control input
INH	7	inhibit output for switching external voltage regulators
ERR_N	8	error and power-on indication output (active LOW)
WAKE	9	local wake-up input
V _{BAT}	10	battery supply voltage
SPLIT	11	common-mode stabilization output
CANL	12	LOW-level CAN bus line
CANH	13	HIGH-level CAN bus line
STB_N	14	standby control input (active LOW)

[1] For enhanced thermal and electrical performance, the exposed center pad of the HVSON14 package should be soldered to board ground (and not to any other voltage level).

7. Functional description

The TJA1043 is a stand-alone high-speed CAN transceiver with a number of operating modes, fail-safe features and diagnostic features that offer enhanced system reliability and advanced power management. The transceiver combines the functionality of the

TJA1041A with improved EMC and ESD capability and quiescent current performance. Improved slope control and high DC handling capability on the bus pins provide additional application flexibility.

7.1 Operating modes

The TJA1043 supports five operating modes. Control pins STB_N and EN are used to select the operating mode. Switching between modes allows access to a number of diagnostics flags via pin ERR_N. [Table 4](#) describes how to switch between modes. [Figure 4](#) illustrates the mode transitions when V_{CC} , V_{IO} and V_{BAT} are valid.

Table 4. Operating mode selection

Internal flags			Control pins		Operating mode	Pin INH
UV _{NOM} ^[1]	UV _{BAT}	Wake ^[2]	STB_N ^[3]	EN		
From Normal, Listen-only, Standby and Go-to-Sleep modes						
set	X	X	X	X	Sleep mode	floating
cleared	set	X	HIGH	X	Standby mode	HIGH
cleared	X	set	LOW	X	Standby mode	HIGH
cleared	X	cleared	LOW	LOW	Standby mode	HIGH
cleared	X	cleared	LOW	HIGH	Go-to-Sleep mode ^[4]	HIGH ^[4]
cleared	cleared	X	HIGH	LOW	Listen-only mode	HIGH
cleared	cleared	X	HIGH	HIGH	Normal mode	HIGH
From Sleep mode						
set	X	X	X	X	Sleep mode	floating
cleared	set	X	HIGH	X	Standby mode	HIGH
cleared	X	set	LOW	X	Standby mode	HIGH
cleared	X	cleared	LOW	X	Sleep mode	floating
cleared	cleared	X	HIGH	LOW	Listen-only mode	HIGH
cleared	cleared	X	HIGH	HIGH	Normal mode	HIGH

[1] Setting the UV_{NOM} flag will clear the WAKE flag.

[2] Setting the Wake flag will clear the UV_{NOM} flag.

[3] A LOW-to-HIGH transition on pin STB_N will clear the UV_{NOM} flag

[4] After the minimum hold time, in Go-to-Sleep mode, $t_{h(min)}$, the transceiver will enter Sleep mode and pin INH will be set floating.

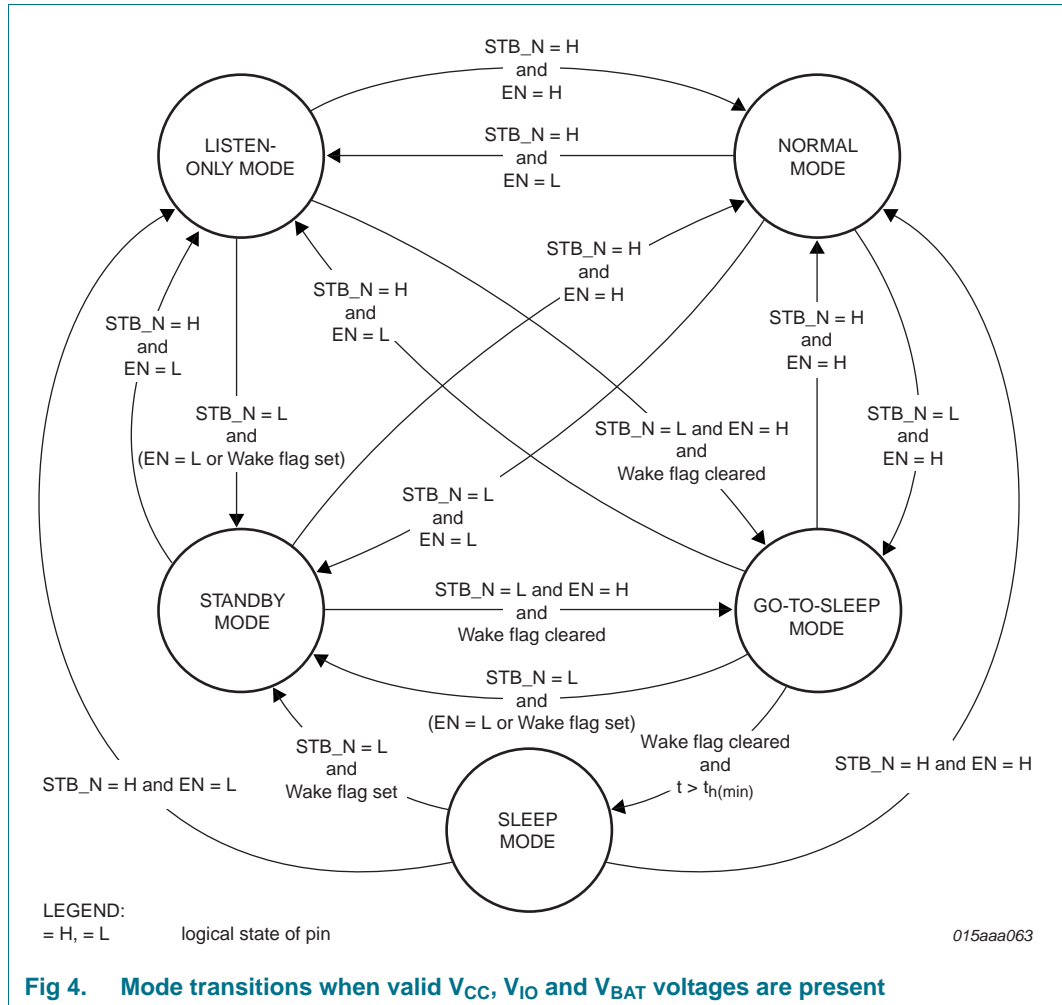

7.1.1 Normal mode

In Normal mode, the transceiver can transmit and receive data via the bus lines CANH and CANL (see [Figure 1](#) for the block diagram). The differential receiver converts the analog data on the bus lines into digital data which is output to pin RXD. The slope of the output signals on the bus lines is controlled and optimized in a way that guarantees the lowest possible EME. The bus pins are biased to $0.5V_{CC}$ (via R_i). Pin INH is active, so voltage regulators controlled by pin INH (see [Figure 7](#)) will be active too.

7.1.2 Listen-only mode

In Listen-only mode, the transceiver's transmitter is disabled, effectively providing a transceiver listen-only feature. The receiver will still convert the analog bus signal on pins CANH and CANL into digital data, available for output on pin RXD. As in Normal mode, the bus pins are biased at $0.5V_{CC}$ and pin INH remains active.

7.1.3 Standby mode

Standby mode is the TJA1043's first-level power saving mode, offering reduced current consumption. In Standby mode, the transceiver is unable to transmit or receive data and the low-power receiver is activated to monitor bus activity. The bus pins are biased at ground level (via R_i). Pin INH is still active, so voltage regulators controlled by this pin will also be active.

Pins RXD and ERR_N will reflect any active wake-up requests (provided that V_{IO} and V_{BAT} are present).

7.1.4 Go-to-Sleep mode

Go-to-Sleep mode is the controlled route for entering Sleep mode. In Go-to-Sleep mode, the transceiver behaves as in Standby mode, with the addition that a go-to-sleep command is issued to the transceiver. The transceiver will remain in Go-to-Sleep mode for the minimum hold time ($t_{h(min)}$) before entering Sleep mode. The transceiver will not enter Sleep mode if the state of pin STB_N or pin EN is changed or if the Wake flag is set before $t_{h(min)}$ has elapsed.

7.1.5 Sleep mode

Sleep mode is the TJA1043's second-level power saving mode. Sleep mode is entered via Go-to-Sleep mode, and also when the undervoltage detection time on either V_{CC} or V_{IO} elapses before the relevant voltage level has recovered. In Sleep mode, the transceiver behaves as described for Standby mode, with the exception that pin INH is set floating. Voltage regulators controlled by this pin will be switched off, and the current into pin V_{BAT} will be reduced to a minimum. Pins STB_N, EN and the Wake flag can be used to wake up a node from Sleep mode (see [Table 4](#)).

7.2 Internal flags

The TJA1043 makes use of seven internal flags for its fail-safe fallback mode control and system diagnosis support. Five of these flags can be polled by the controller via pin ERR_N. Which flag is available on pin ERR_N at any time depends on the active operating mode and on a number of other conditions. [Table 5](#) describes how to access these flags.

Table 5. Accessing internal flags via pin ERR_N

Internal flag	Flag is available on pin ERR_N ^[1]	Flag is cleared
UV_{NOM}	no	by setting the Pwon or Wake flags, by a LOW-to-HIGH transition on STB_N or when both V_{IO} and V_{BAT} have recovered.
UV_{BAT}	no	when V_{BAT} has recovered
Pwon	in Listen-only mode (coming from Standby mode, Go-to-Sleep mode, or Sleep mode)	on entering Normal mode
Wake	in Standby mode, Go-to-Sleep mode, and Sleep mode (provided that V_{IO} and V_{BAT} are present)	on entering Normal mode or by setting the UV_{NOM} flag

Table 5. Accessing internal flags via pin ERR_N ...continued

Internal flag	Flag is available on pin ERR_N ^[1]	Flag is cleared
Wake-up source	in Normal mode (before the fourth dominant-to-recessive edge on pin TXD ^[2])	on leaving Normal mode
Bus failure	in Normal mode (after the fourth dominant-to-recessive edge on pin TXD ^[2])	on re-entering Normal mode or by setting the Pwon flag
Local failure	in Listen-only mode (coming from Normal mode)	on entering Normal mode or when RXD is dominant while TXD is recessive (provided that all local failures are resolved) or by setting the Pwon flag

[1] Pin ERR_N is an active-LOW output, so a LOW-level indicates a set flag and a HIGH-level indicates a cleared flag. Allow pin ERR_N to stabilize for at least 8 μ s after changing operating modes.

[2] Allow for a TXD dominant time of at least 4 μ s per dominant-recessive cycle.

7.2.1 UV_{NOM} flag

UV_{NOM} is the V_{CC} and V_{IO} undervoltage detection flag. The flag is set when the voltage on pin V_{CC} drops below the V_{CC} undervoltage detection voltage, V_{uvd(VCC)}, for longer than the undervoltage detection time, t_{det(uv)}, or when the voltage on pin V_{IO} drops below V_{uvd(VIO)} for longer than t_{det(uv)}. When the UV_{NOM} flag is set, the transceiver enters Sleep mode to save power and to ensure the bus is not disturbed. In Sleep mode the voltage regulators connected to pin INH are disabled, avoiding any extra power consumption that might be generated as a result of a short-circuit condition.

Any wake-up request, setting the Pwon flag or a LOW-to-HIGH transition on STB_N will clear UV_{NOM} and the timers, allowing the voltage regulators to be reactivated (at least until UV_{NOM} is set again). UV_{NOM} will also be cleared if both V_{CC} and V_{IO} recover for longer than the undervoltage recovery time, t_{rec(uv)}. The transceiver will then switch to the operating mode indicated by the logic levels on pins STB_N and EN (see [Table 4](#)).

7.2.2 UV_{BAT} flag

UV_{BAT} is the V_{BAT} undervoltage detection flag. This flag is set when the voltage on pin V_{BAT} drops below V_{uvd(VBAT)}. When UV_{BAT} is set, the transceiver will try to enter Standby mode to save power and will disengage from the bus (zero load). UV_{BAT} is cleared when the voltage on pin V_{BAT} recovers. The transceiver will then switch to the operating mode indicated by the logic levels on pins STB_N and EN (see [Table 4](#)).

7.2.3 Pwon flag

Pwon is the V_{BAT} power-on flag. This flag is set when the voltage on pin V_{BAT} recovers after previously dropping below V_{uvd(VBAT)} (usually because the battery was disconnected). Setting the Pwon flag clears the UV_{NOM} flag and timers. The Wake and Wake-up source flags are set to ensure consistent system power-up under all supply conditions. In Listen-only mode the Pwon flag can be polled via pin ERR_N (see [Table 5](#)). The flag is cleared when the transceiver enters Normal mode.

7.2.4 Wake flag

The Wake flag is set when the transceiver detects a local or remote wake-up request. A local wake-up request is detected when the logic level on pin WAKE changes, and the new level remains stable for at least t_{wake}. A remote wake-up request is triggered by two bus dominant states of at least t_{wake(busdom)}, with the first dominant state followed by a

recessive state of at least $t_{\text{wake(busrec)}}$ (provided the complete dominant-recessive-dominant pattern is completed within $t_{\text{to(wake)bus}}$). The Wake flag can be set in Standby mode, Go-to-Sleep mode or Sleep mode. Setting the Wake flag clears the UV_{NOM} flag and timers. Once set, the Wake flag status is immediately available on pins ERR_N and RXD (provided V_{IO} and V_{BAT} are present). This flag is also set at power-on and cleared when the UV_{NOM} flag is set or the transceiver enters Normal mode.

7.2.5 Wake-up source flag

Wake-up source recognition is provided via the Wake-up source flag, which is set when the Wake flag is set by a local wake-up request via the WAKE pin. The Wake-up source flag can be polled via the ERR_N pin in Normal mode (see [Table 5](#)). This flag is also set at power-on and cleared when the transceiver leaves Normal mode.

7.2.6 Bus failure flag

The Bus failure flag is set if the transceiver detects a bus line short-circuit condition to V_{BAT} , V_{CC} or GND during four consecutive dominant-recessive cycles on pin TXD, while trying to drive the bus lines dominant. The Bus failure flag can be polled via the ERR_N pin in Normal mode (see [Table 5](#)). This flag is cleared at power-on or when the transceiver re-enters Normal mode.

7.2.7 Local failure flag

In Normal and Listen-only modes, the transceiver can distinguish four different local failure events, any of which will cause the Local failure flag to be set. The four local failure events are: TXD dominant clamping, TXD-to-RXD short circuit, bus dominant clamping and an overtemperature event. The nature and detection of these local failures is described in [Section 7.3](#). The Local failure flag can be polled via the ERR_N pin in Listen-only mode (see [Table 5](#)). This flag is cleared at power-on, when entering Normal mode or when RXD is dominant while TXD is recessive, provided that all local failures have been resolved.

7.3 Local failures

The TJA1043 can detect four different local failure conditions. Any of these failures will set the Local failure flag, and in most cases the transmitter of the transceiver will be disabled.

7.3.1 TXD dominant clamping detection

A permanent LOW level on pin TXD (due to a hardware or software application failure) would drive the CAN bus into a permanent dominant state, blocking all network communications. The TXD dominant time-out function prevents such a network lock-up by disabling the transmitter if pin TXD remains LOW for longer than the TXD dominant time-out time $t_{\text{to(dom)TXD}}$. The $t_{\text{to(dom)TXD}}$ timer defines the minimum possible bit rate of 40 kbit/s. The transmitter remains disabled until the Local failure flag has been cleared.

7.3.2 TXD-to-RXD short-circuit detection

A short-circuit between pins RXD and TXD would lock the bus in a permanent dominant state once it had been driven dominant, because the low-side driver of RXD is typically stronger than the high-side driver of the controller connected to TXD. TXD-to-RXD short-circuit detection prevents such a network lock-up by disabling the transmitter. The transmitter remains disabled until the Local failure flag has been cleared.

7.3.3 Bus dominant clamping detection

A CAN bus short circuit (to V_{BAT} , V_{CC} or GND) or a failure in one of the other network nodes could result in a differential voltage on the bus high enough to represent a bus dominant state. Because a node will not start transmission if the bus is dominant, the normal bus failure detection will not detect this failure, but the bus dominant clamping detection will. The Local failure flag is set if the dominant state on the bus persists for longer than $t_{to(dom)bus}$. By checking this flag, the controller can determine if a clamped bus is blocking network communications. There is no need to disable the transmitter. Note that the Local failure flag does not retain a bus dominant clamping failure, and is released as soon as the bus returns to recessive state.

7.3.4 Overtemperature detection

If the junction temperature becomes excessive, the transmitter will shut down in time to protect the output drivers from overheating without compromising the maximum operating temperature. The transmitter will remain disabled until the Local failure flag has been cleared.

7.4 SPLIT pin

Using the SPLIT pin on the TJA1043 in conjunction with a split termination network (see [Figure 5](#) and [Figure 7](#)) can help to stabilize the recessive voltage level on the bus. This will reduce EME in networks with DC leakage to ground (e.g. from deactivated nodes with poor bus leakage performance). In Normal and Listen-only modes, pin SPLIT delivers a DC output voltage of $0.5V_{CC}$. In Standby, Go-to-Sleep and Sleep modes, pin SPLIT is floating.

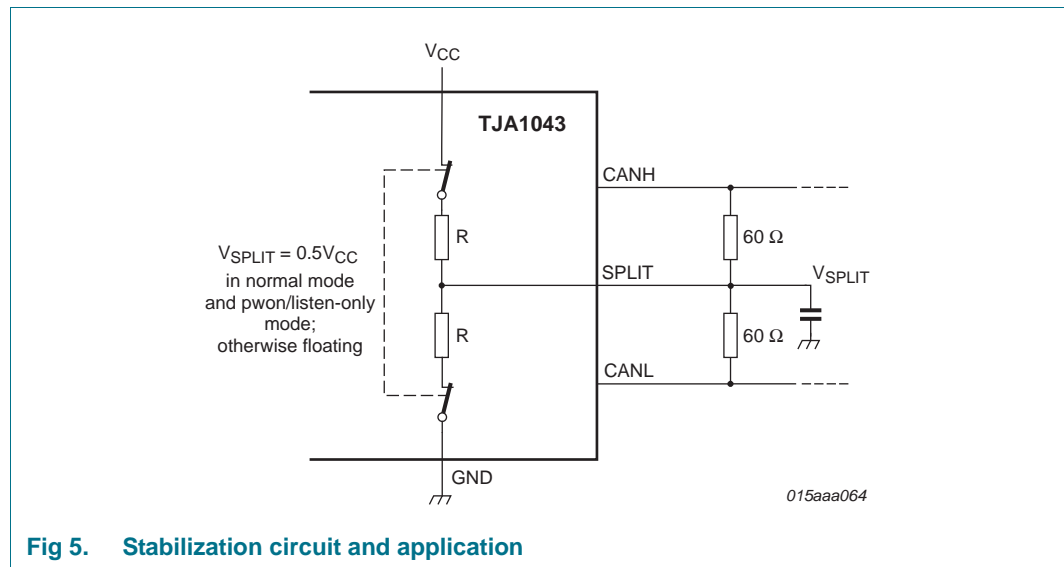

Fig 5. Stabilization circuit and application

7.5 V_{IO} supply pin

Pin V_{IO} should be connected to the microcontroller supply voltage (see [Figure 7](#)). This will cause the signal levels of pins TXD, RXD, STB_N, EN and ERR_N to be adjusted to the I/O levels of the microcontroller, facilitating direct interfacing without the need for glue logic.

7.6 WAKE pin

A local wake-up event is triggered by a LOW-to-HIGH or HIGH-to-LOW transition on the WAKE pin, allowing for maximum flexibility when designing a local wake-up circuit. To minimize current consumption, the internal bias voltage will follow the logic state on the pin after a delay of t_{wake} . A HIGH level on pin WAKE is followed by an internal pull-up to V_{BAT} . A LOW level on pin WAKE is followed by an internal pull-down towards GND. In applications that don't make use of the local wake-up facility, it is recommended that the WAKE pin be connected to V_{BAT} or GND to ensure optimal EMI performance.

8. Limiting values

Table 6. Limiting values

In accordance with the Absolute Maximum Rating System (IEC 60134).

Symbol	Parameter	Conditions	Min	Max	Unit	
V _{BAT}	battery supply voltage	no time limit	-0.3	+58	V	
		load dump	-	58	V	
V _x	voltage on pin x	no time limit; DC value				
		on pins CANH, CANL and SPLIT	-58	+58	V	
		on pins INH and WAKE	-0.3	+58	V	
		on pins V _{CC} , V _{IO} , TXD, RXD, STB_N, EN, ERR_N	-0.3	+7	V	
I _{WAKE}	current on pin WAKE	DC value	-	-15	mA	
V _{trt}	transient voltage	on pins CANH, CANL, SPLIT and V _{BAT}	[1]	-200	+200	V
V _{ESD}	electrostatic discharge voltage	IEC 61000-4-2	[2]			
		at pins CANH and CANL	[3]	-8	+8	kV
		HBM	[4]			
		at pins CANH and CANL		-8	+8	kV
		at any other pin		-4	+4	kV
		MM	[5]			
		at any pin		-300	+300	V
CDM		[6]				
		at corner pins		-750	+750	V
		at any pin		-500	+500	V
T _{vj}	virtual junction temperature		[7]	-40	+150	°C
T _{stg}	storage temperature			-55	+150	°C

[1] Verified by an external test house to ensure pins CANH, CANL, SPLIT and V_{BAT} can withstand ISO 7637 part 3 automotive transient test pulses 1, 2a, 3a and 3b.

[2] IEC 61000-4-2 (150 pF, 330 Ω); direct coupling.

[3] ESD performance of pins CANH and CANL according to IEC 61000-4-2 (150 pF, 330 Ω) has been verified by an external test house. The result is equal to or better than ±8 kV (unaided).

[4] Human Body Model (HBM): according to AEC-Q100-002 (100 pF, 1.5 kΩ).

[5] Machine Model (MM): according to AEC-Q100-003 (200 pF, 0.75 μH, 10 Ω).

[6] Charged Device Model (CDM): according to AEC-Q100-011 (field induced charge; 4 pF); grade C3B.

[7] In accordance with IEC 60747-1. An alternative definition of virtual junction temperature is: $T_{vj} = T_{amb} + P \times R_{th(vj-a)}$, where $R_{th(vj-a)}$ is a fixed value to be used for the calculation of T_{vj} . The rating for T_{vj} limits the allowable combinations of power dissipation (P) and ambient temperature (T_{amb}).

9. Thermal characteristics

Table 7. Thermal characteristics

Value determined for free convection conditions on a JEDEC 2S2P board.

Symbol	Parameter	Conditions	Typ	Unit
R _{th(vj-a)}	thermal resistance from virtual junction to ambient	SO14 package; in free air	68	K/W
		HVSON14 package; in free air	44	K/W

10. Static characteristics

Table 8. Static characteristics

$V_{CC} = 4.5\text{ V to }5.5\text{ V}$; $V_{IO} = 2.8\text{ V to }V_{CC}$; $V_{BAT} = 4.5\text{ V to }40\text{ V}$; $R_L = 60\ \Omega$; $T_{vj} = -40\text{ }^\circ\text{C to }+150\text{ }^\circ\text{C}$; unless otherwise specified; all voltages are defined with respect to ground; positive currents flow into the device [1].

Symbol	Parameter	Conditions	Min	Typ	Max	Unit
Supply pin V_{CC}						
V_{CC}	supply voltage		4.5	-	5.5	V
$V_{\text{uvd}(V_{CC})}$	undervoltage detection voltage on pin V_{CC}	$V_{BAT} > 4.5\text{ V}$	3	3.5	4.3	V
I_{CC}	supply current	Normal mode; $V_{TXD} = 0\text{ V}$ (dominant)	30	48	65	mA
		Normal or Listen-only mode; $V_{TXD} = V_{IO}$ (recessive)	3	6	9	mA
		Standby or Sleep mode; $V_{BAT} > V_{CC}$	0	0.75	2	μA
I/O level adapter supply; pin V_{IO}						
V_{IO}	supply voltage on pin V_{IO}		2.8	-	5.5	V
$V_{\text{uvd}(V_{IO})}$	undervoltage detection voltage on pin V_{IO}	V_{BAT} or $V_{CC} > 4.5\text{ V}$	0.8	1.8	2.5	V
I_{IO}	supply current on pin V_{IO}	Normal mode; $V_{TXD} = 0\text{ V}$ (dominant)	-	150	500	μA
		Normal or Listen-only mode; $V_{TXD} = V_{IO}$ (recessive)	0	1	4	μA
		Standby or Sleep mode	0	1	4	μA
Supply pin V_{BAT}						
V_{BAT}	battery supply voltage		4.5	-	40	V
$V_{\text{uvd}(V_{BAT})}$	undervoltage detection voltage on pin V_{BAT}		3	3.5	4.3	V
I_{BAT}	battery supply current	Normal or Listen-only mode	15	40	70	μA
		Standby mode; $V_{CC} > 4.5\text{ V}$ $V_{INH} = V_{WAKE} = V_{BAT}$	5	18	30	μA
		Sleep mode; $V_{INH} = V_{CC} = V_{IO} = 0\text{ V}$; $V_{WAKE} = V_{BAT}$	5	18	30	μA
CAN transmit data input; pin TXD						
V_{IH}	HIGH-level input voltage		$0.7V_{IO}$	-	$V_{IO} + 0.3$	V
V_{IL}	LOW-level input voltage		-0.3	-	$+0.3V_{IO}$	V
I_{IH}	HIGH-level input current	$V_{TXD} = V_{IO}$	-5	0	+5	μA
I_{IL}	LOW-level input current	Normal mode; $V_{TXD} = 0\text{ V}$	-300	-200	-30	μA
C_i	input capacitance	not tested	-	5	10	pF
CAN receive data output; pin RXD						
I_{OH}	HIGH-level output current	$V_{RXD} = V_{IO} - 0.4\text{ V}$; $V_{IO} = V_{CC}$	-12	-6	0	mA
I_{OL}	LOW-level output current	$V_{RXD} = 0.4\text{ V}$; $V_{TXD} = V_{IO}$; bus dominant	0	6	14	mA
Standby and enable control inputs; pins STB_N and EN						
V_{IH}	HIGH-level input voltage		$0.7V_{IO}$	-	$V_{IO} + 0.3$	V
V_{IL}	LOW-level input voltage		-0.3	-	$0.3V_{IO}$	V
I_{IH}	HIGH-level input current	$V_{STB_N} = V_{EN} = 0.7V_{IO}$	1	4	10	μA

Table 8. Static characteristics ...continued

$V_{CC} = 4.5\text{ V to }5.5\text{ V}$; $V_{IO} = 2.8\text{ V to }V_{CC}$; $V_{BAT} = 4.5\text{ V to }40\text{ V}$; $R_L = 60\ \Omega$; $T_{vj} = -40\text{ }^\circ\text{C to }+150\text{ }^\circ\text{C}$; unless otherwise specified; all voltages are defined with respect to ground; positive currents flow into the device [1].

Symbol	Parameter	Conditions	Min	Typ	Max	Unit
I_{IL}	LOW-level input current	$V_{STB_N} = V_{EN} = 0\text{ V}$	-1	0	+1	μA
Error and power-on indication output; pin ERR_N						
I_{OH}	HIGH-level output current	$V_{ERR_N} = V_{IO} - 0.4\text{ V}$; $V_{IO} = V_{CC}$	-50	-20	-4	μA
I_{OL}	LOW-level output current	$V_{ERR_N} = 0.4\text{ V}$	0.1	0.5	2	mA
Local wake-up input; pin WAKE						
I_{IH}	HIGH-level input current	$V_{WAKE} = V_{BAT} - 1.9\text{ V}$	-10	-5	-1	μA
I_{IL}	LOW-level input current	$V_{WAKE} = V_{BAT} - 3.1\text{ V}$	1	5	10	μA
V_{th}	threshold voltage	$V_{STB_N} = 0\text{ V}$	$V_{BAT} - 3$	$V_{BAT} - 2.5$	$V_{BAT} - 2$	V
Inhibit output; pin INH						
ΔV_H	HIGH-level voltage drop	$I_{INH} = -0.18\text{ mA}$	0	0.25	0.8	V
I_L	leakage current	Sleep mode	-2	0	+2	μA
Bus lines; pins CANH and CANL						
$V_{O(\text{dom})}$	dominant output voltage	$V_{TXD} = 0\text{ V}$; $t < t_{to(\text{dom})TXD}$				
		pin CANH	2.75	3.5	4.5	V
		pin CANL	0.5	1.5	2.25	V
$V_{\text{dom}(\text{TX})\text{sym}}$	transmitter dominant voltage symmetry	$V_{\text{dom}(\text{TX})\text{sym}} = V_{CC} - V_{\text{CANH}} - V_{\text{CANL}}$	-400	-	+400	mV
$V_{O(\text{dif})\text{bus}}$	bus differential output voltage	$V_{TXD} = 0\text{ V}$; $V_{CC} = 4.75\text{ V to }5.25\text{ V}$; $45\ \Omega < R_L < 65\ \Omega$; dominant	1.5	-	3.0	V
		$V_{TXD} = V_{IO}$; recessive; no load	-50	-	+50	mV
$V_{O(\text{rec})}$	recessive output voltage	Normal or Listen-only mode; $V_{TXD} = V_{IO}$; no load	2	$0.5V_{CC}$	3	V
		Standby or Sleep mode; no load	-0.1	0	+0.1	V
$I_{O(\text{sc})}$	short-circuit output current	$V_{TXD} = 0\text{ V}$ (dominant); $V_{CC} = 5\text{ V}$				
		pin CANH; $V_{\text{CANH}} = 0\text{ V}$	-100	-70	-40	mA
		pin CANL; $V_{\text{CANL}} = 40\text{ V}$	40	70	100	mA
$I_{O(\text{rec})}$	recessive output current	$-27\text{ V} < V_{\text{CAN}} < 32\text{ V}$	-3	-	+3	mA
$V_{th(\text{RX})\text{dif}}$	differential receiver threshold voltage	$V_{\text{cm}(\text{CAN})} = -30\text{ V to }+30\text{ V}$ [2]				
		Normal or Listen-only mode	0.5	0.7	0.9	V
		Standby or Sleep mode	0.4	0.7	1.15	V
$V_{\text{hys}(\text{RX})\text{dif}}$	differential receiver hysteresis voltage	Normal or Listen-only mode [2]	50	120	400	mV
		$V_{\text{cm}(\text{CAN})} = -30\text{ V to }+30\text{ V}$				
I_{LI}	input leakage current	$V_{CC} = 0\text{ V}$; $V_{\text{CANH}} = V_{\text{CANL}} = 5\text{ V}$	100	170	250	μA
		$V_{BAT} = 0\text{ V}$; $V_{\text{CANH}} = V_{\text{CANL}} = 5\text{ V}$	-2	-	+2	μA
R_i	input resistance		9	15	28	$\text{k}\Omega$
ΔR_i	input resistance deviation	between V_{CANH} and V_{CANL}	-3	0	+3	%
$R_{i(\text{dif})}$	differential input resistance		19	30	52	$\text{k}\Omega$
$C_{i(\text{cm})}$	common-mode input capacitance	$V_{TXD} = V_{CC}$ [3]	-	-	20	pF
$C_{i(\text{dif})}$	differential input capacitance	$V_{TXD} = V_{CC}$ [3]	-	-	10	pF

Table 8. Static characteristics ...continued

$V_{CC} = 4.5\text{ V to }5.5\text{ V}$; $V_{IO} = 2.8\text{ V to }V_{CC}$; $V_{BAT} = 4.5\text{ V to }40\text{ V}$; $R_L = 60\ \Omega$; $T_{vj} = -40\text{ }^\circ\text{C to }+150\text{ }^\circ\text{C}$; unless otherwise specified; all voltages are defined with respect to ground; positive currents flow into the device [\[1\]](#).

Symbol	Parameter	Conditions	Min	Typ	Max	Unit
Common-mode stabilization output; pin SPLIT						
V_O	output voltage	Normal or Listen-only mode; $-500\ \mu\text{A} < I_{\text{SPLIT}} < 500\ \mu\text{A}$	$0.3V_{CC}$	$0.5V_{CC}$	$0.7V_{CC}$	V
		Normal or Listen-only mode $R_L = 1\ \text{M}\Omega$	$0.45V_{CC}$	$0.5V_{CC}$	$0.55V_{CC}$	V
I_L	leakage current	Standby or Sleep mode; $-58\text{ V} < V_{\text{SPLIT}} < +58\text{ V}$	-3	0	+3	μA
Temperature detection						
$T_{j(\text{sd})}$	shutdown junction temperature		[3] -	190	-	$^\circ\text{C}$

[1] All parameters are guaranteed over the virtual junction temperature range by design. Factory testing uses correlated test conditions to cover the specified temperature and power supply voltage range.

[2] $V_{\text{cm}(\text{CAN})}$ is the common mode voltage of CANH and CANL.

[3] Not tested in production; guaranteed by design.

11. Dynamic characteristics

Table 9. Dynamic characteristics;

$V_{CC} = 4.5\text{ V to }5.5\text{ V}$; $V_{IO} = 2.8\text{ V to }V_{CC}$; $V_{BAT} = 4.5\text{ V to }40\text{ V}$; $R_L = 60\ \Omega$; $T_{vj} = -40\text{ }^\circ\text{C to }+150\text{ }^\circ\text{C}$; unless otherwise specified; all voltages are defined with respect to ground; positive currents flow into the device [\[1\]](#).

Symbol	Parameter	Conditions	Min	Typ	Max	Unit
Timing characteristics; Figure 6						
$t_{\text{d}(\text{TXD-busdom})}$	delay time from TXD to bus dominant	Normal mode	-	70	-	ns
$t_{\text{d}(\text{TXD-busrec})}$	delay time from TXD to bus recessive	Normal mode	-	90	-	ns
$t_{\text{d}(\text{busdom-RXD})}$	delay time from bus dominant to RXD	Normal or Listen-only mode	-	60	-	ns
$t_{\text{d}(\text{busrec-RXD})}$	delay time from bus recessive to RXD	Normal or Listen-only mode	-	70	-	ns
$t_{\text{PD}(\text{TXD-RXD})}$	propagation delay from TXD to RXD	$V_{\text{STB}_N} = 0\text{ V}$	40	-	240	ns
$t_{\text{def}(\text{uv})}$	undervoltage detection time		100	-	350	ms
$t_{\text{rec}(\text{uv})}$	undervoltage recovery time		1	-	5	ms
$t_{\text{to}(\text{dom})\text{TXD}}$	TXD dominant time-out time	$V_{\text{TXD}} = 0\text{ V}$	0.3	0.6	1.5	ms
$t_{\text{to}(\text{dom})\text{bus}}$	bus dominant time-out time	$V_{\text{O}(\text{dif})(\text{bus})} > 0.9\text{ V}$	0.3	0.6	1.5	ms
t_{h}	hold time	from issuing go-to-sleep command to entering Sleep mode	20	35	50	μs
$t_{\text{wake}(\text{busdom})}$	bus dominant wake-up time	Standby or Sleep mode; $V_{\text{BAT}} = 12\text{ V}$	0.5	1.75	5	μs
$t_{\text{wake}(\text{busrec})}$	bus recessive wake-up time	Standby or Sleep mode; $V_{\text{BAT}} = 12\text{ V}$	0.5	1.75	5	μs
$t_{\text{to}(\text{wake})\text{bus}}$	bus wake-up time-out time		0.5	-	2	ms
t_{wake}	wake-up time	in response to a falling or rising edge on pin WAKE; Standby or Sleep mode	5	25	50	μs

[1] All parameters are guaranteed over the virtual junction temperature range by design. Factory testing uses correlated test conditions to cover the specified temperature and power supply voltage range.

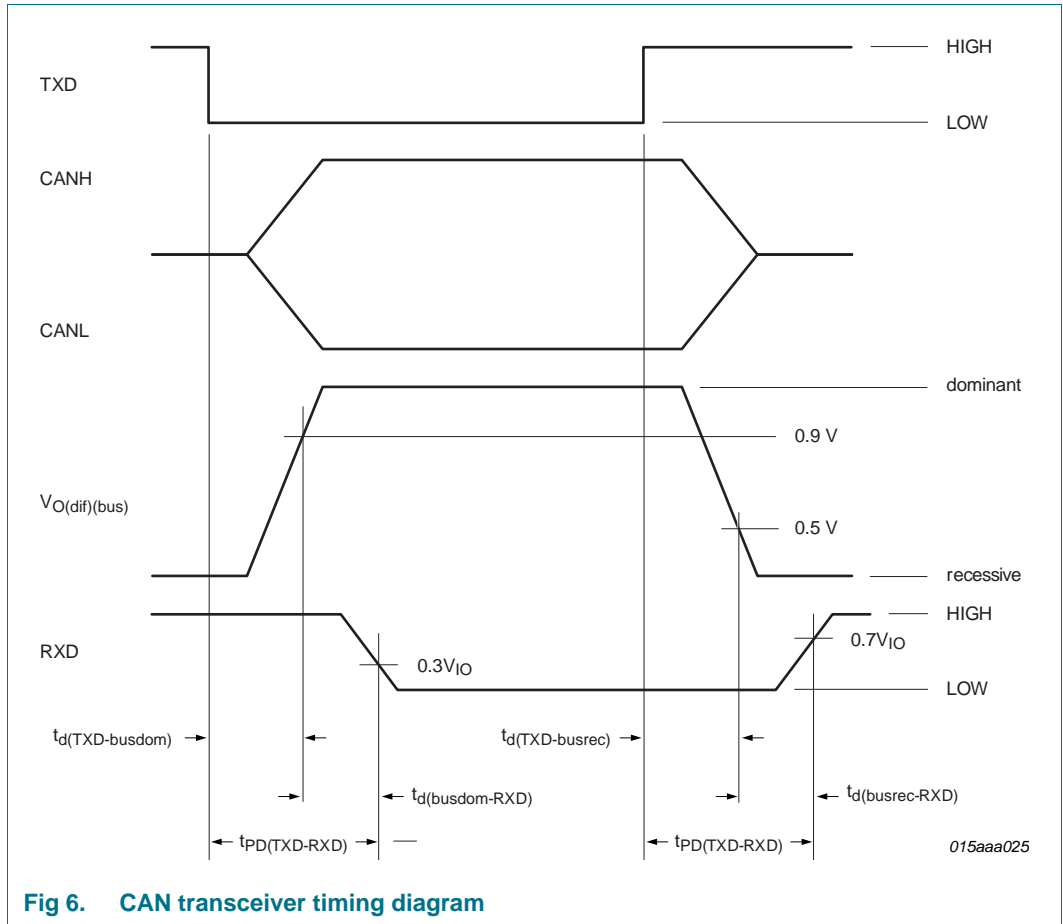

Fig 6. CAN transceiver timing diagram

12. Application information

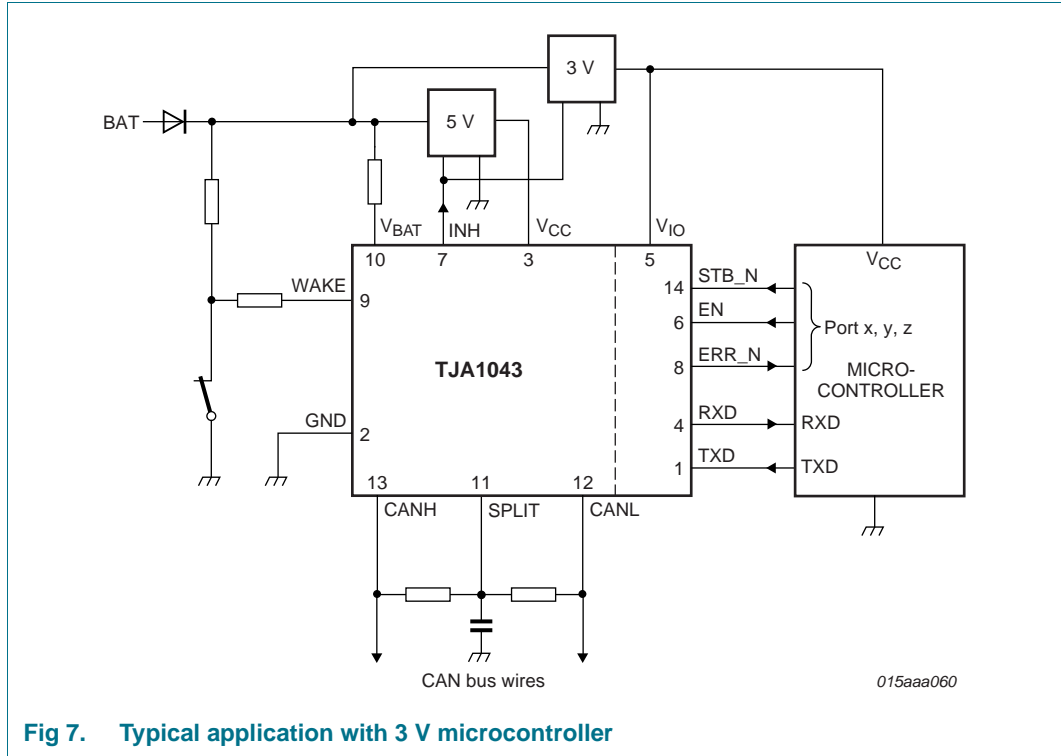
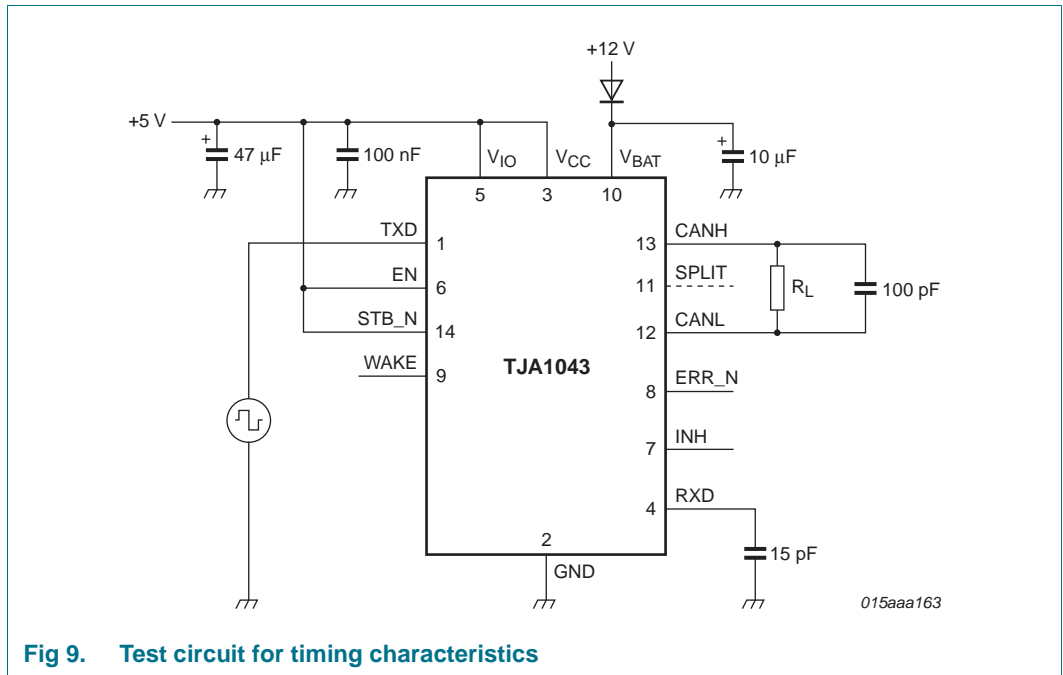
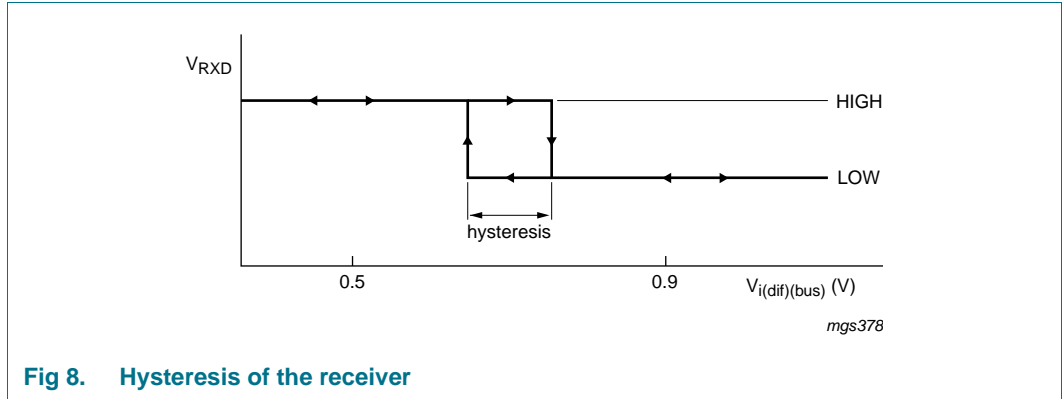

Fig 7. Typical application with 3 V microcontroller

13. Test information



13.1 Quality information

This product has been qualified in accordance with the Automotive Electronics Council (AEC) standard Q100 Rev-G - *Failure mechanism based stress test qualification for integrated circuits*, and is suitable for use in automotive applications.

14. Package outline

SO14: plastic small outline package; 14 leads; body width 3.9 mm

SOT108-1

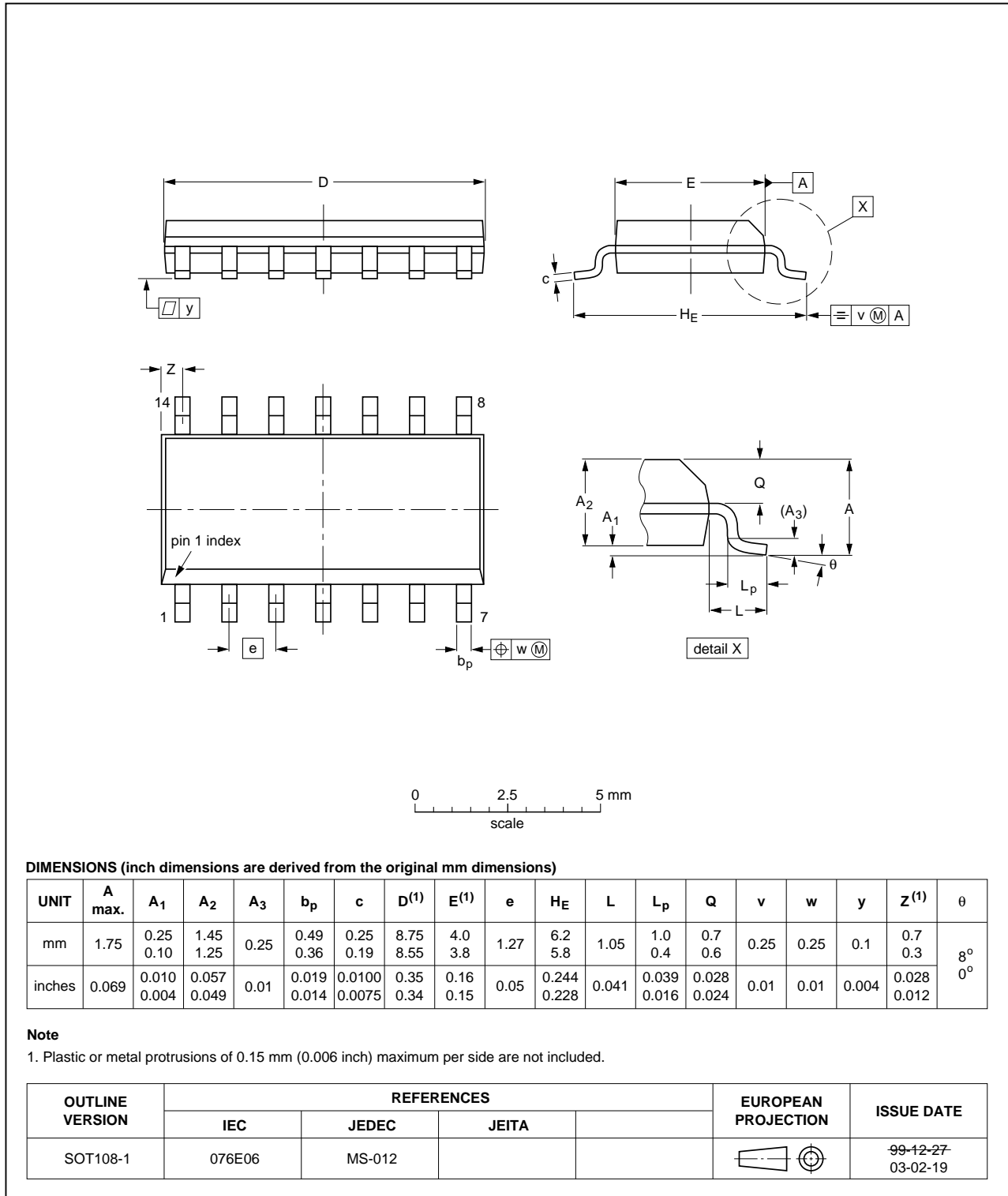

Fig 10. Package outline SOT108-1 (SO14)

HVSON14: plastic, thermal enhanced very thin small outline package; no leads; 14 terminals; body 3 x 4.5 x 0.85 mm

SOT1086-2

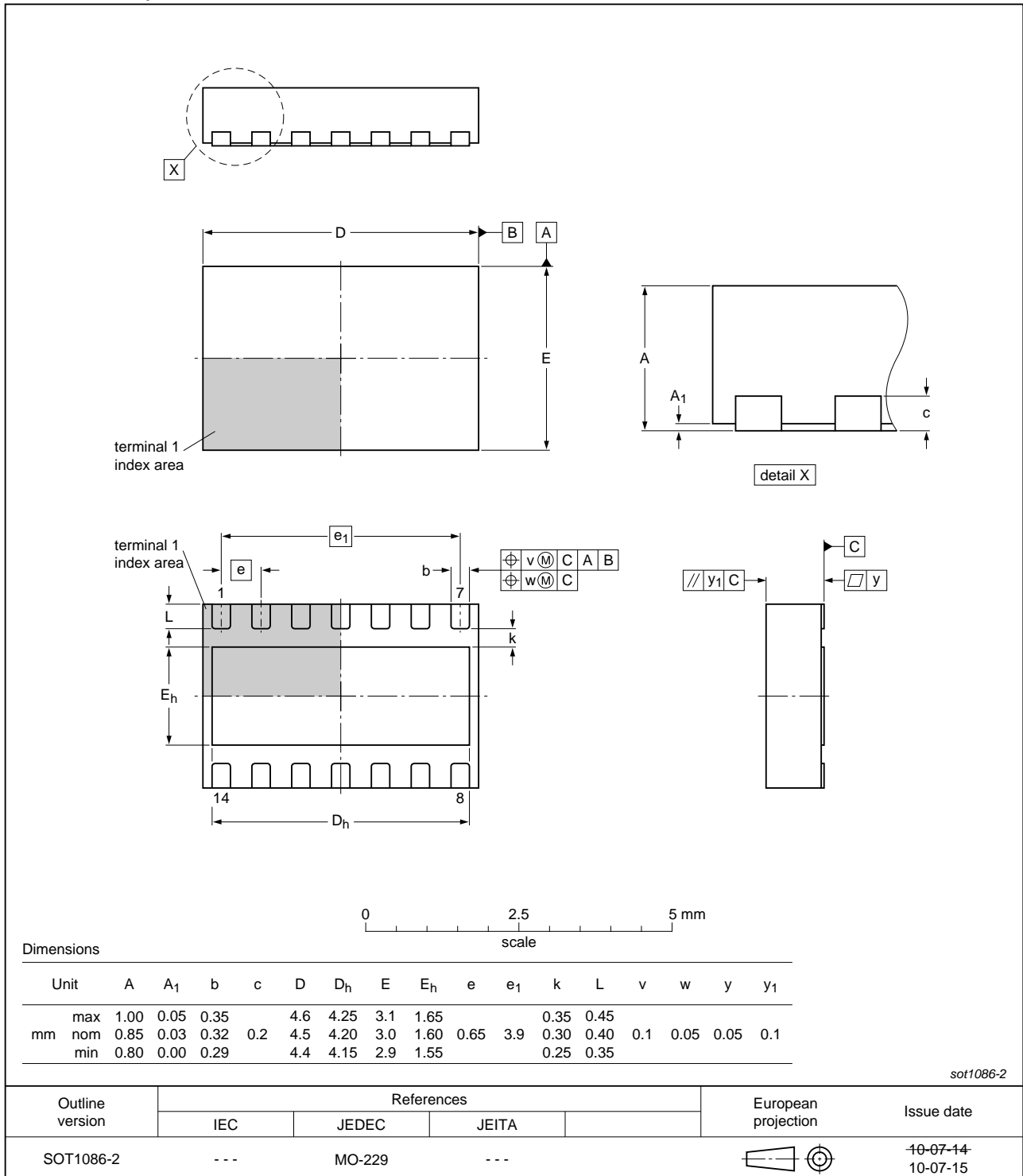

Fig 11. Package outline SOT1086 (HVSON14)

15. Handling information

All input and output pins are protected against ElectroStatic Discharge (ESD) under normal handling. When handling ensure that the appropriate precautions are taken as described in *JESD625-A* or equivalent standards.

16. Soldering of SMD packages

This text provides a very brief insight into a complex technology. A more in-depth account of soldering ICs can be found in Application Note *AN10365 "Surface mount reflow soldering description"*.

16.1 Introduction to soldering

Soldering is one of the most common methods through which packages are attached to Printed Circuit Boards (PCBs), to form electrical circuits. The soldered joint provides both the mechanical and the electrical connection. There is no single soldering method that is ideal for all IC packages. Wave soldering is often preferred when through-hole and Surface Mount Devices (SMDs) are mixed on one printed wiring board; however, it is not suitable for fine pitch SMDs. Reflow soldering is ideal for the small pitches and high densities that come with increased miniaturization.

16.2 Wave and reflow soldering

Wave soldering is a joining technology in which the joints are made by solder coming from a standing wave of liquid solder. The wave soldering process is suitable for the following:

- Through-hole components
- Leaded or leadless SMDs, which are glued to the surface of the printed circuit board

Not all SMDs can be wave soldered. Packages with solder balls, and some leadless packages which have solder lands underneath the body, cannot be wave soldered. Also, leaded SMDs with leads having a pitch smaller than ~0.6 mm cannot be wave soldered, due to an increased probability of bridging.

The reflow soldering process involves applying solder paste to a board, followed by component placement and exposure to a temperature profile. Leaded packages, packages with solder balls, and leadless packages are all reflow solderable.

Key characteristics in both wave and reflow soldering are:

- Board specifications, including the board finish, solder masks and vias
- Package footprints, including solder thieves and orientation
- The moisture sensitivity level of the packages
- Package placement
- Inspection and repair
- Lead-free soldering versus SnPb soldering

16.3 Wave soldering

Key characteristics in wave soldering are:

- Process issues, such as application of adhesive and flux, clinching of leads, board transport, the solder wave parameters, and the time during which components are exposed to the wave
- Solder bath specifications, including temperature and impurities

16.4 Reflow soldering

Key characteristics in reflow soldering are:

- Lead-free versus SnPb soldering; note that a lead-free reflow process usually leads to higher minimum peak temperatures (see [Figure 12](#)) than a SnPb process, thus reducing the process window
- Solder paste printing issues including smearing, release, and adjusting the process window for a mix of large and small components on one board
- Reflow temperature profile; this profile includes preheat, reflow (in which the board is heated to the peak temperature) and cooling down. It is imperative that the peak temperature is high enough for the solder to make reliable solder joints (a solder paste characteristic). In addition, the peak temperature must be low enough that the packages and/or boards are not damaged. The peak temperature of the package depends on package thickness and volume and is classified in accordance with [Table 10](#) and [11](#)

Table 10. SnPb eutectic process (from J-STD-020D)

Package thickness (mm)	Package reflow temperature (°C)	
	Volume (mm ³)	
	< 350	≥ 350
< 2.5	235	220
≥ 2.5	220	220

Table 11. Lead-free process (from J-STD-020D)

Package thickness (mm)	Package reflow temperature (°C)		
	Volume (mm ³)		
	< 350	350 to 2000	> 2000
< 1.6	260	260	260
1.6 to 2.5	260	250	245
> 2.5	250	245	245

Moisture sensitivity precautions, as indicated on the packing, must be respected at all times.

Studies have shown that small packages reach higher temperatures during reflow soldering, see [Figure 12](#).

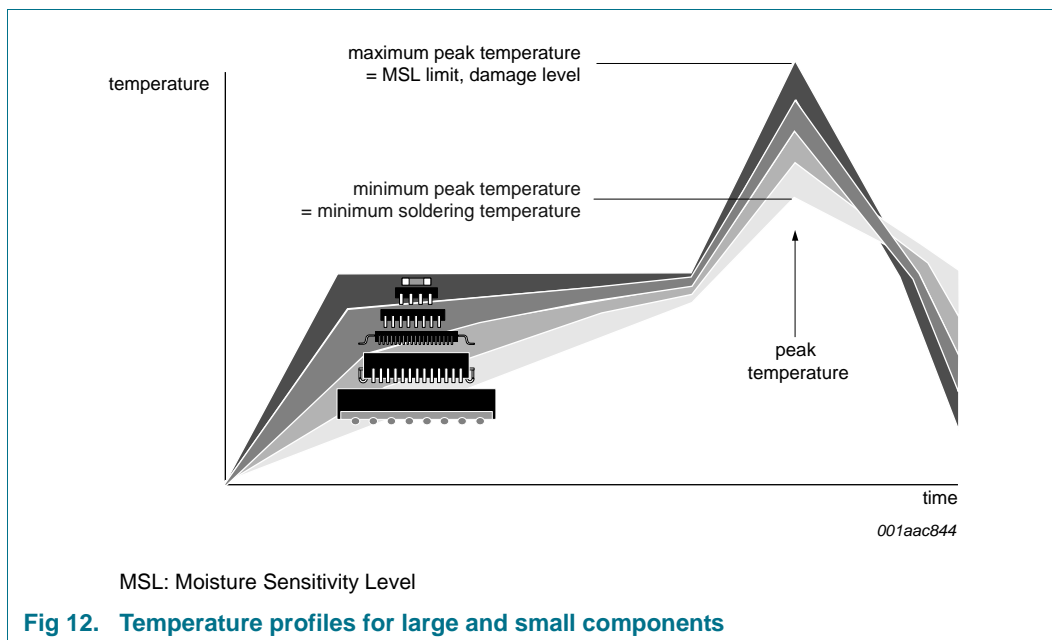

For further information on temperature profiles, refer to Application Note *AN10365* “*Surface mount reflow soldering description*”.

17. Soldering of HVSON packages

[Section 16](#) contains a brief introduction to the techniques most commonly used to solder Surface Mounted Devices (SMD). A more detailed discussion on soldering HVSON leadless package ICs can be found in the following application notes:

- *AN10365* “*Surface mount reflow soldering description*”
- *AN10366* “*HVQFN application information*”

18. Revision history

Table 12. Revision history

Document ID	Release date	Data sheet status	Change notice	Supersedes
TJA1043 v.3	20130424	Product data sheet	-	TJA1043 v.2
Modifications:	<ul style="list-style-type: none">• Section 2.1: revised• Added HVSON14 package (Table 2, Figure 3, Table 7, Figure 11)• Table 3: table note section added• Section 13.1 text revised• Section 17: added			
TJA1043 v.2	20110620	Product data sheet	-	TJA1043 v.1
TJA1043 v.1	20100330	Product data sheet	-	-

19. Legal information

19.1 Data sheet status

Document status ^{[1][2]}	Product status ^[3]	Definition
Objective [short] data sheet	Development	This document contains data from the objective specification for product development.
Preliminary [short] data sheet	Qualification	This document contains data from the preliminary specification.
Product [short] data sheet	Production	This document contains the product specification.

[1] Please consult the most recently issued document before initiating or completing a design.

[2] The term 'short data sheet' is explained in section "Definitions".

[3] The product status of device(s) described in this document may have changed since this document was published and may differ in case of multiple devices. The latest product status information is available on the Internet at URL <http://www.nxp.com>.

19.2 Definitions

Draft — The document is a draft version only. The content is still under internal review and subject to formal approval, which may result in modifications or additions. NXP Semiconductors does not give any representations or warranties as to the accuracy or completeness of information included herein and shall have no liability for the consequences of use of such information.

Short data sheet — A short data sheet is an extract from a full data sheet with the same product type number(s) and title. A short data sheet is intended for quick reference only and should not be relied upon to contain detailed and full information. For detailed and full information see the relevant full data sheet, which is available on request via the local NXP Semiconductors sales office. In case of any inconsistency or conflict with the short data sheet, the full data sheet shall prevail.

Product specification — The information and data provided in a Product data sheet shall define the specification of the product as agreed between NXP Semiconductors and its customer, unless NXP Semiconductors and customer have explicitly agreed otherwise in writing. In no event however, shall an agreement be valid in which the NXP Semiconductors product is deemed to offer functions and qualities beyond those described in the Product data sheet.

19.3 Disclaimers

Limited warranty and liability — Information in this document is believed to be accurate and reliable. However, NXP Semiconductors does not give any representations or warranties, expressed or implied, as to the accuracy or completeness of such information and shall have no liability for the consequences of use of such information. NXP Semiconductors takes no responsibility for the content in this document if provided by an information source outside of NXP Semiconductors.

In no event shall NXP Semiconductors be liable for any indirect, incidental, punitive, special or consequential damages (including - without limitation - lost profits, lost savings, business interruption, costs related to the removal or replacement of any products or rework charges) whether or not such damages are based on tort (including negligence), warranty, breach of contract or any other legal theory.

Notwithstanding any damages that customer might incur for any reason whatsoever, NXP Semiconductors' aggregate and cumulative liability towards customer for the products described herein shall be limited in accordance with the *Terms and conditions of commercial sale* of NXP Semiconductors.

Right to make changes — NXP Semiconductors reserves the right to make changes to information published in this document, including without limitation specifications and product descriptions, at any time and without notice. This document supersedes and replaces all information supplied prior to the publication hereof.

Suitability for use in automotive applications — This NXP Semiconductors product has been qualified for use in automotive applications. Unless otherwise agreed in writing, the product is not designed, authorized or warranted to be suitable for use in life support, life-critical or safety-critical systems or equipment, nor in applications where failure or malfunction of an NXP Semiconductors product can reasonably be expected to result in personal injury, death or severe property or environmental damage. NXP Semiconductors and its suppliers accept no liability for inclusion and/or use of NXP Semiconductors products in such equipment or applications and therefore such inclusion and/or use is at the customer's own risk.

Applications — Applications that are described herein for any of these products are for illustrative purposes only. NXP Semiconductors makes no representation or warranty that such applications will be suitable for the specified use without further testing or modification.

Customers are responsible for the design and operation of their applications and products using NXP Semiconductors products, and NXP Semiconductors accepts no liability for any assistance with applications or customer product design. It is customer's sole responsibility to determine whether the NXP Semiconductors product is suitable and fit for the customer's applications and products planned, as well as for the planned application and use of customer's third party customer(s). Customers should provide appropriate design and operating safeguards to minimize the risks associated with their applications and products.

NXP Semiconductors does not accept any liability related to any default, damage, costs or problem which is based on any weakness or default in the customer's applications or products, or the application or use by customer's third party customer(s). Customer is responsible for doing all necessary testing for the customer's applications and products using NXP Semiconductors products in order to avoid a default of the applications and the products or of the application or use by customer's third party customer(s). NXP does not accept any liability in this respect.

Limiting values — Stress above one or more limiting values (as defined in the Absolute Maximum Ratings System of IEC 60134) will cause permanent damage to the device. Limiting values are stress ratings only and (proper) operation of the device at these or any other conditions above those given in the Recommended operating conditions section (if present) or the Characteristics sections of this document is not warranted. Constant or repeated exposure to limiting values will permanently and irreversibly affect the quality and reliability of the device.

Terms and conditions of commercial sale — NXP Semiconductors products are sold subject to the general terms and conditions of commercial sale, as published at <http://www.nxp.com/profile/terms>, unless otherwise agreed in a valid written individual agreement. In case an individual agreement is concluded only the terms and conditions of the respective agreement shall apply. NXP Semiconductors hereby expressly objects to applying the customer's general terms and conditions with regard to the purchase of NXP Semiconductors products by customer.

No offer to sell or license — Nothing in this document may be interpreted or construed as an offer to sell products that is open for acceptance or the grant, conveyance or implication of any license under any copyrights, patents or other industrial or intellectual property rights.

Export control — This document as well as the item(s) described herein may be subject to export control regulations. Export might require a prior authorization from competent authorities.

Quick reference data — The Quick reference data is an extract of the product data given in the Limiting values and Characteristics sections of this document, and as such is not complete, exhaustive or legally binding.

19.4 Trademarks

Notice: All referenced brands, product names, service names and trademarks are the property of their respective owners.

20. Contact information

For more information, please visit: <http://www.nxp.com>

For sales office addresses, please send an email to: salesaddresses@nxp.com

21. Contents

1	General description	1	16.1	Introduction to soldering	21
2	Features and benefits	1	16.2	Wave and reflow soldering	21
2.1	General	1	16.3	Wave soldering	21
2.2	Low-power management	2	16.4	Reflow soldering	22
2.3	Protection and diagnosis (detection and signalling)	2	17	Soldering of HVSON packages	23
3	Quick reference data	2	18	Revision history	24
4	Ordering information	2	19	Legal information	25
5	Block diagram	3	19.1	Data sheet status	25
6	Pinning information	4	19.2	Definitions	25
6.1	Pinning	4	19.3	Disclaimers	25
6.2	Pin description	4	19.4	Trademarks	26
7	Functional description	4	20	Contact information	26
7.1	Operating modes	5	21	Contents	27
7.1.1	Normal mode	6			
7.1.2	Listen-only mode	6			
7.1.3	Standby mode	7			
7.1.4	Go-to-Sleep mode	7			
7.1.5	Sleep mode	7			
7.2	Internal flags	7			
7.2.1	UV _{NOM} flag	8			
7.2.2	UV _{BAT} flag	8			
7.2.3	Pwon flag	8			
7.2.4	Wake flag	8			
7.2.5	Wake-up source flag	9			
7.2.6	Bus failure flag	9			
7.2.7	Local failure flag	9			
7.3	Local failures	9			
7.3.1	TXD dominant clamping detection	9			
7.3.2	TXD-to-RXD short-circuit detection	9			
7.3.3	Bus dominant clamping detection	10			
7.3.4	Overtemperature detection	10			
7.4	SPLIT pin	10			
7.5	V _{IO} supply pin	10			
7.6	WAKE pin	11			
8	Limiting values	12			
9	Thermal characteristics	12			
10	Static characteristics	13			
11	Dynamic characteristics	15			
12	Application information	17			
13	Test information	18			
13.1	Quality information	18			
14	Package outline	19			
15	Handling information	21			
16	Soldering of SMD packages	21			

Please be aware that important notices concerning this document and the product(s) described herein, have been included in section 'Legal information'.

© NXP B.V. 2013.

All rights reserved.

For more information, please visit: <http://www.nxp.com>

For sales office addresses, please send an email to: salesaddresses@nxp.com

Date of release: 24 April 2013

Document identifier: TJA1043