



TEA19161CT

Digital controller for high-efficiency resonant power supply

Rev. 2 — 26 February 2020

Product data sheet

1 General description

The TEA19161CT is a fully digital controller for high-efficiency resonant power supplies. Together with the TEA19162CT PFC controller and the TEA1995T dual SR controller, a complete resonant power supply can be built which is easy to design and has a very low component count. This power supply meets the efficiency regulations of Energy Star, the Department of Energy (DoE), the Eco-design directive of the European Union, the European Code of Conduct, and other guidelines. So, any auxiliary low-power supply can be omitted.

In contrast to traditional resonant topologies, the TEA19161CT (LLC) shows a high efficiency at low loads due to the newly introduced low-power mode. This mode operates in the power region between continuous switching (also called high-power mode) and burst mode.

Because the TEA19161CT is regulated via the primary capacitor voltage, it has accurate information about the power delivered to the output. The measured output power defines the mode of operation (burst mode, low-power mode, or high-power mode). A configuration pin can easily set the transition levels of the operating modes.

The TEA19161CT contains a low-voltage die with a fully digital controller for output power control, start-up, initializations, and protections. These protections include overcurrent protection (OCP), overvoltage protection (OVP), open-loop protection (OLP), and capacitive mode regulation (CMR). It also contains a high-voltage silicon-on-insulator (SOI) controller for high-voltage start-up, integrated drivers, level shifter, protections, and circuitry assuring zero-voltage switching.

The TEA19161CT is designed to cooperate with the TEA19162CT power factor control (PFC) controller. For communications about start-up and protections, the TEA19161CT contains a digital control interface. The digital control enables a fast latch reset mechanism. It maximizes the overall system efficiency at low output power levels by setting the TEA19162CT to operate in burst mode.

The TEA19161CT/TEA19162CT/TEA1995T combination gives an easy to design, highly efficient, and reliable power supply, providing 90 W to 500 W, with a minimum of external components. The system provides a very low no-load input power (< 75 mW; total system including the TEA19161CT/TEA19162CT/TEA1995T combination) and high efficiency from minimum to maximum load. So, any additional low-power supply can be omitted, ensuring a significant system cost saving and highly simplified power supply design.



2 Features and benefits

2.1 Distinctive features

- Complete functionality as a combination with TEA19162CT
- Integrated high-voltage start-up
- Integrated high-voltage level shifter (LS)
- Extremely fast start-up (< 500 ms at $V_{\text{mains}} = 100 \text{ V (AC)}$)
- Continuously V_{SUPIC} regulation via the SUPHV pin during start-up and protection, allowing minimum SUPIC capacitor values
- Operating frequencies are outside the audible area at all operating modes
- Integrated soft start
- Power good function
- Maximum 500 kHz half-bridge switching frequency

2.2 Green features

- Extremely high efficiency from low load to high load
- Compliant with Energy using Product directive (EuP) lot 6
- Excellent no-load input power (< 75 mW for TEA19161CT/TEA19162CT/TEA1995T combination)
- Regulated low optocurrent, enabling low no-load power consumption
- Very low supply current during non-switching state in burst mode
- Transition between different operation modes (high-power/low-power/burst mode) occurs at integrated, externally adjustable power levels
- Adaptive non-overlap time

2.3 Protection features

- Supply undervoltage protection (UVP)
- Overpower protection (OPP)
- Integrated adjustable overpower timeout
- Adjustable latch or restart function for overpower protection (OPP)
- On-chip overtemperature protection (OTP)
- Capacitive mode regulation (CMR)
- Accurate overvoltage protection (OVP)
- Maximum on-time protection for low-side and high-side driver output
- Overcurrent protection (OCP)
- Disable input

3 Applications

- Desktop and all-in-one PCs
- LCD television
- Notebook adapter
- Printers

4 Ordering information

Table 1. Ordering information

Type number	Package		Version
	Name	Description	
TEA19161CT/1	SO16	plastic small outline package; 16 leads; body width 3.9 mm	SOT109-1

5 Marking

Table 2. Marking

Type number	Marking code
TEA19161CT/1	TEA19161CT

6 Block diagram

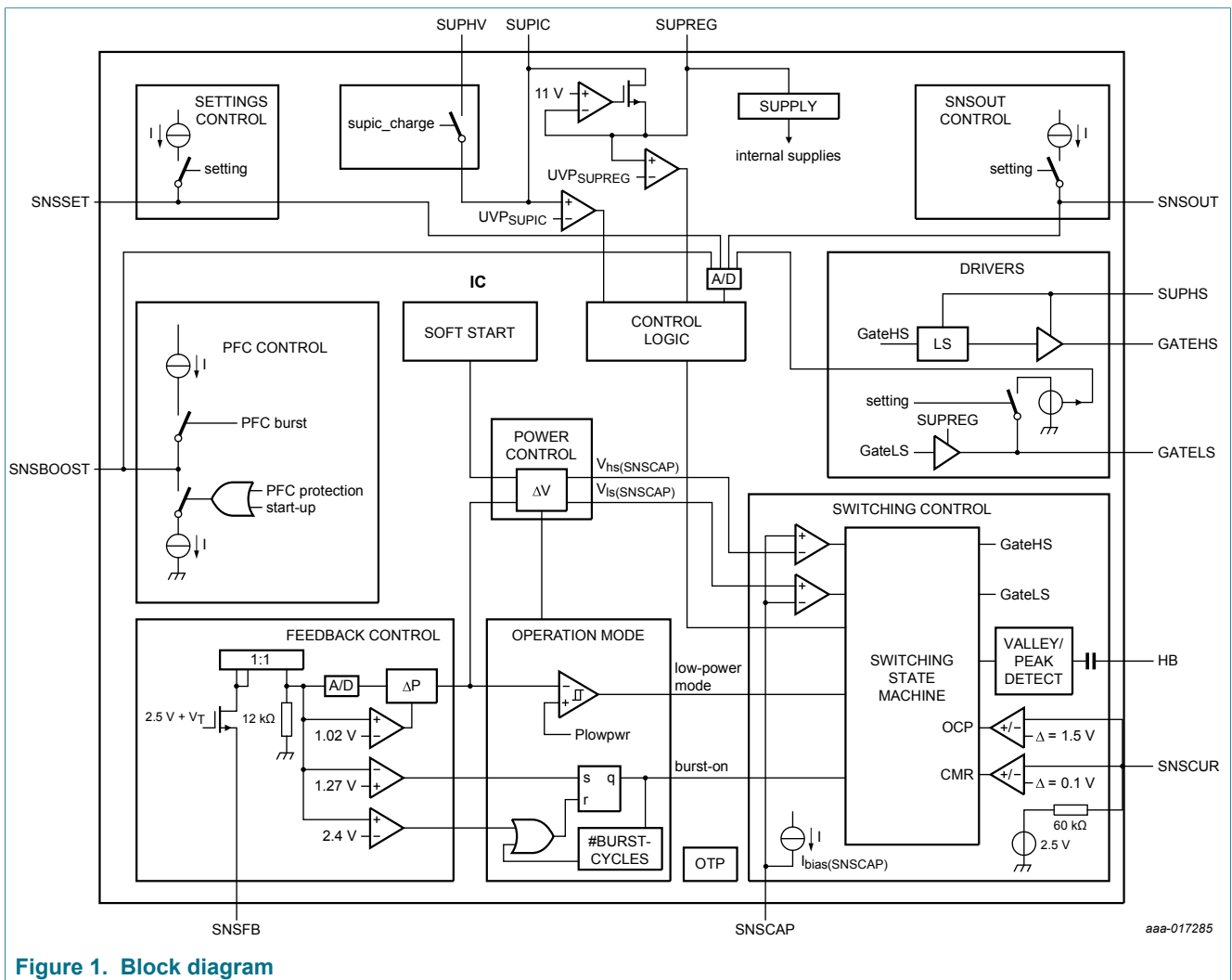

Figure 1. Block diagram

7 Pinning information

7.1 Pinning

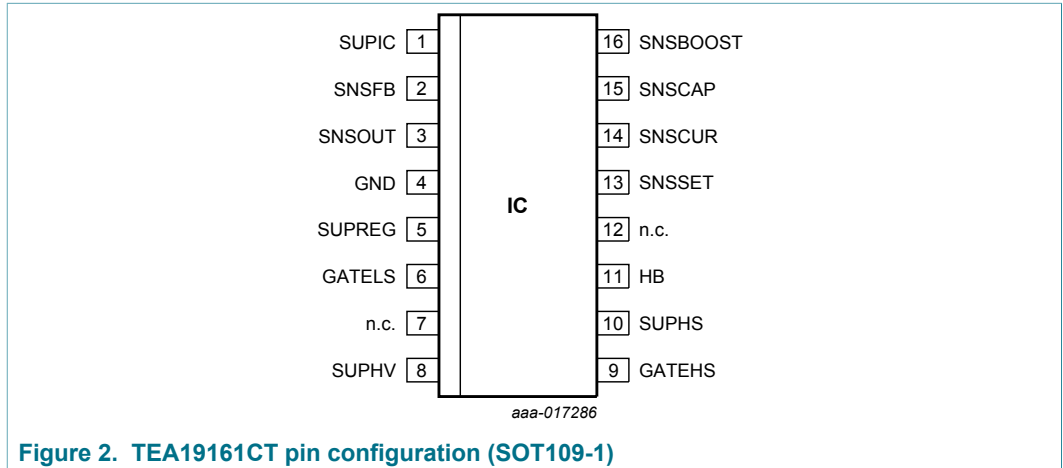

Figure 2. TEA19161CT pin configuration (SOT109-1)

7.2 Pin description

Table 3. Pin description

Symbol	Pin	Description
SUPIC	1	input supply voltage and output of internal HV start-up source; externally connected to an auxiliary winding of the LLC via a diode or to an external DC supply
SNSFB	2	output voltage regulation feedback sense input; externally connected to an optocoupler
SNSOUT	3	sense input for setting the burst frequency and monitoring the LLC output voltage; externally via a resistive divider and a diode connected to the auxiliary winding
GND	4	ground
SUPREG	5	regulated SUPREG IC supply; internal regulator output; input for drivers; externally connected to SUPREG buffer capacitor
GATELS	6	LLC low-side MOSFET gate driver output
n.c.	7	not connected
SUPHV	8	internal HV start-up source high-voltage supply input; externally connected to (PFC) boost voltage
GATEHS	9	LLC high-side MOSFET gate driver output
SUPHS	10	high-side driver supply input; externally connected to bootstrap capacitor (C_{SUPHS})
HB	11	low-level reference for high-side driver and input for half-bridge slope detection; externally connected to half-bridge node HB between the LLC MOSFETs
n.c.	12	not connected

Symbol	Pin	Description
SNSSET	13	settings for transition levels high/low power mode and low-power/burst mode, overpower level, overpower timeout, and restart or latched. Output of the power good signal.
SNSCUR	14	LLC current sense input; externally connected to the resonant current sense resistor
SNSCAP	15	LLC capacitor voltage sense input; externally connected to divider across LLC capacitor
SNSBOOST	16	sense input for boost voltage; output for PFC burst control; externally connected to resistive divided boost voltage

8 Functional description

8.1 Supply voltages

The TEA19161CT includes:

- A high-voltage supply pin for start-up (SUPHV)
- A general supply to be connected to an external auxiliary winding (SUPIC pin)
- An accurate regulated voltage (SUPREG pin)
- A floating supply for the high-side driver (SUPHS pin)

8.1.1 Start-up and supply voltage

Initially, the capacitors on the SUPIC and SUPREG pins are charged via the SUPHV pin. The SUPHV pin is connected to the output voltage of a PFC via an external resistor. Internally, a high-voltage series switch is located between the SUPHV and SUPIC pins. From the SUPIC pin, the SUPREG pin is supplied using a linear regulator (see [Figure 3](#)).

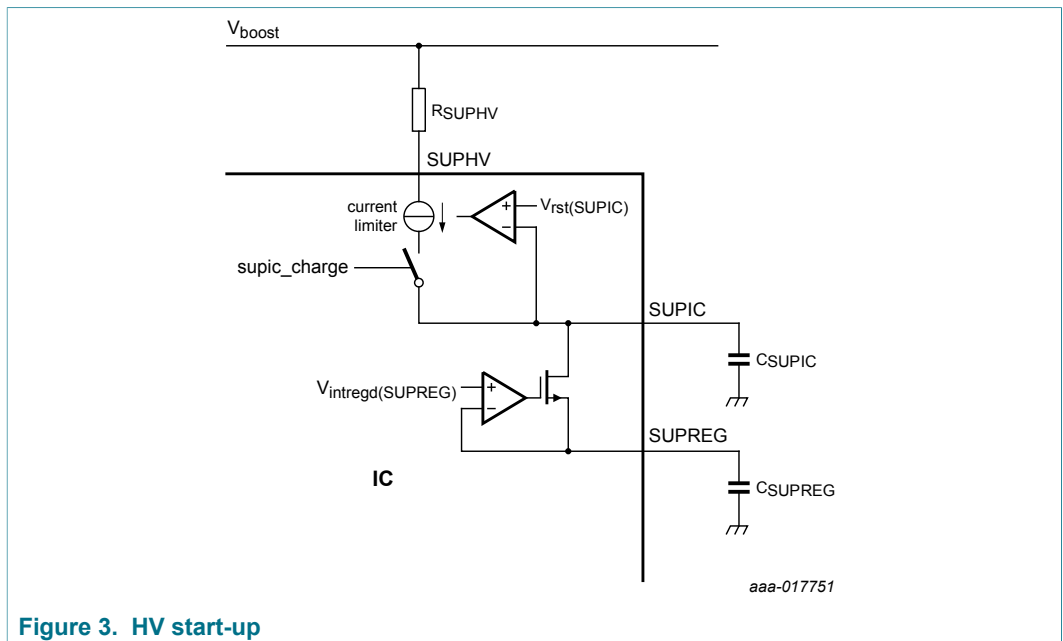

Figure 3. HV start-up

Initially, when the voltage on the SUPIC pin is below the reset level $V_{rstSUPIC}$ (3.5 V), the SUPIC charge current is internally limited to $I_{lim(SUPHV)}$ (0.75 mA). In this way, the dissipation is limited when SUPIC is shorted to ground. When the voltage on the SUPIC pin exceeds $V_{rst(SUPIC)}$, the internal switch is closed.

To limit the IC power dissipation, an external resistor (R_{SUPHV}) is required to reduce the voltage drop between the SUPHV and SUPIC pins when charging the SUPIC capacitor. R_{SUPHV} must be dimensioned such that the maximum current is limited to below limiting value I_{SUPHV} (20 mA) and it can handle the required power dissipation. The maximum power dissipation of the external resistor can be reduced by using several resistors in series.

When the SUPIC reaches the $V_{start(SUPIC)}$ level (19.1 V), it is continuously regulated to this start level with a hysteresis ($V_{start(hys)(SUPIC)}$; -0.7 V). It activates the switch between the SUPHV and SUPIC pins when the SUPIC voltage drops to below $V_{start(SUPIC)} + V_{start(hys)(SUPIC)}$. It deactivates the switch when it exceeds $V_{start(SUPIC)}$. When start-up is complete and the LLC controller is operating, the LLC transformer auxiliary winding supplies the SUPIC pin. In this operational state, the HV start-up source is disabled (see [Figure 4](#)).

When the system enters the protection mode, the SUPIC pin is also regulated to the start level. During the non-switching period of the burst mode, the system also activates the switch between the SUPHV and SUPIC pins when the SUPIC voltage drops below $V_{low(SUPIC)}$. It regulates the voltage with a hysteresis of $V_{hys(low)SUPIC}$. In this way, the system avoids that the SUPIC undervoltage protection ($V_{uvp(SUPIC)}$) is triggered because of a long non-switching period in burst mode.

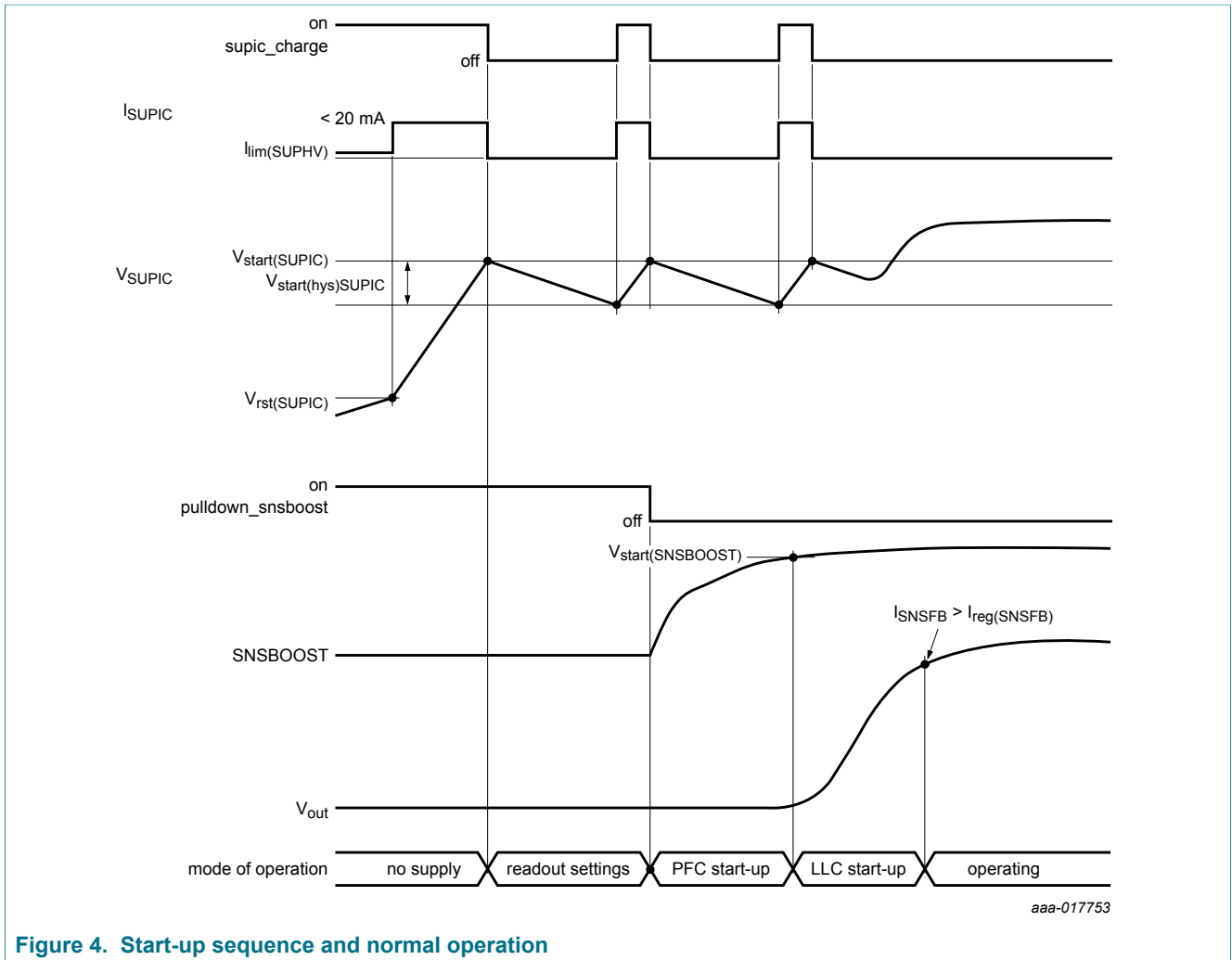

Figure 4. Start-up sequence and normal operation

8.1.2 Regulated supply (SUPREG pin)

The voltage range on the SUPIC pin exceeds that of the maximum external MOSFETs gate-source voltage. So, the TEA19161CT incorporates an integrated series stabilizer. The series stabilizer creates an accurate regulated voltage ($V_{intregd(SUPREG)} = 11\text{ V}$) at the buffer capacitor C_{SUPREG} . The stabilized voltage is used to:

- Supply the internal low-side LLC driver
- Supply the internal high-side driver using external components
- As a reference voltage for optional external circuits

To ensure that the external MOSFETs receive sufficient gate drive, the voltage on the SUPREG pin must reach $V_{uvp(SUPREG)}$ before the system starts switching. If the SUPREG voltage drops to below this undervoltage protection level, the system restarts.

8.1.3 High-side driver floating supply (SUPHS pin)

External bootstrap buffer capacitor C_{SUPHS} supplies the high-side driver. The bootstrap capacitor is connected between the high-side driver supply, the SUPHS pin, and the half-bridge node, HB. C_{SUPHS} is charged from the SUPREG pin using an external diode D_{SUPHS} (see Figure 27).

Careful selection of the appropriate diode minimizes the voltage drop between the SUPREG and SUPHS pins, especially when large MOSFETs and high switching frequencies are used. A large voltage drop across the diode reduces the gate drive of the high-side MOSFET.

8.2 System start-up

Figure 5 shows the flow diagram corresponding with Figure 4.

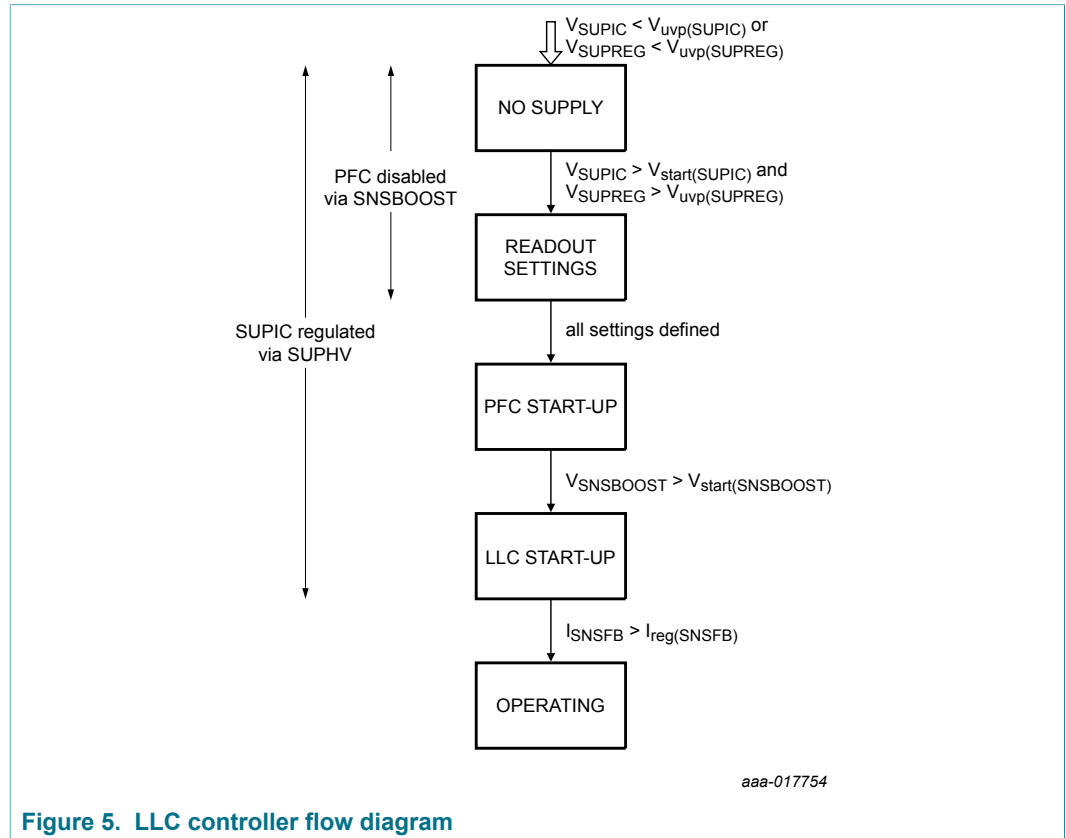

Figure 5. LLC controller flow diagram

When the SUPIC or SUPREG pins drop to below their stop levels, the TEA19161CT enters the no supply state. It recharges the SUPIC and SUPREG pins to their start levels via the SUPHV pin. When the start levels are reached, measuring the external resistances on the SNSSET, SNSOUT, and GATELS pins initialize the settings.

During the no supply and readout settings states, the SNSBOOST pin is pulled low, disabling the TEA19162CT PFC. When the settings have been defined, the SNSBOOST pin is released and the PFC starts up. When the SNSBOOST reaches the minimum level $V_{start(SNSBOOST)}$, the LLC starts switching.

When a small optocurrent is detected ($I_{SNSFB} < I_{reg(SNSFB)}$), the output voltage is close to its regulation level. As the SUPIC pin must then be supplied via the primary auxiliary winding, charging via the SUPHV is disabled.

8.3 LLC system regulation

A typical resonant controller regulates the output power by adapting the operating frequency.

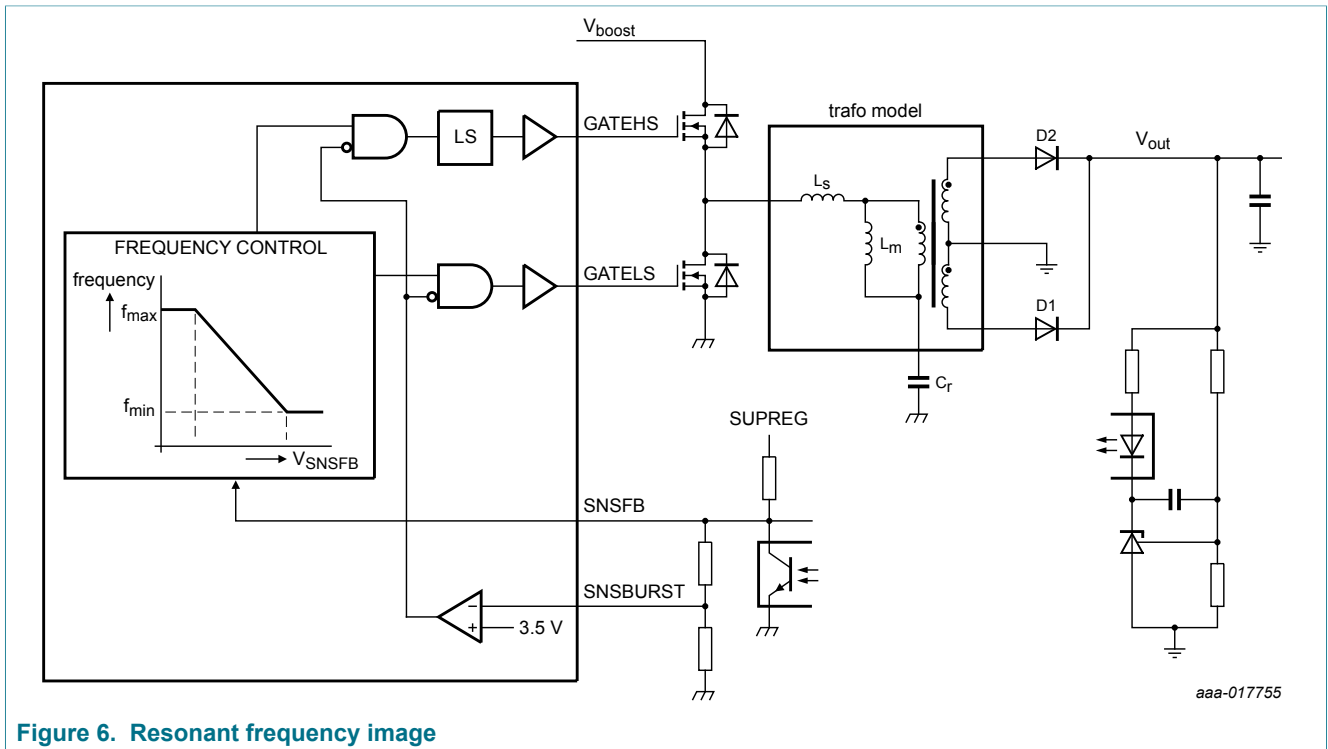

Figure 6. Resonant frequency image

If the power drops and as a result the voltage of the LLC converter exceeds the targeted regulation level (12 V or 19.5 V typical), the optocurrent increases and the voltage at the SNSFB decreases (see Figure 6). The resonant controller then increases the frequency according to its internal frequency control curve. Because of the higher frequency, the power to the output is reduced and the output voltage drops. If the output voltage becomes too low, the controller lowers the system frequency, increasing the output power. In this way, the system regulates the output power to the required level.

An important disadvantage of this control mechanism is the gain of the control loop. A small change in frequency gives a significant change in output power.

Another disadvantage is that when the burst mode level is derived from the voltage on the SNSFB pin, the system enters burst mode at a certain frequency instead of at a certain output power. A small variation of the resonant components results in a significant variation in power level at which the burst mode is activated.

In the TEA19161CT, the control mechanism is different. The controller does not regulate the output power by adjusting the frequency but by the voltage across the primary capacitor.

The input power (related to the output power) of a resonant converter can be calculated with Equation 1:

$$P_{in} = V_{boost} \times I_{boost} = V_{boost} \times \Delta V_{Cr} \times C_r \times f_{sw} \quad (1)$$

Equation 1 shows that the input power has a linear relationship with the capacitor voltage difference ΔV_{C_r} .

Figure 7 shows an alternative explanation of the linear relationship between the input power and the energy stored in the resonant capacitor.

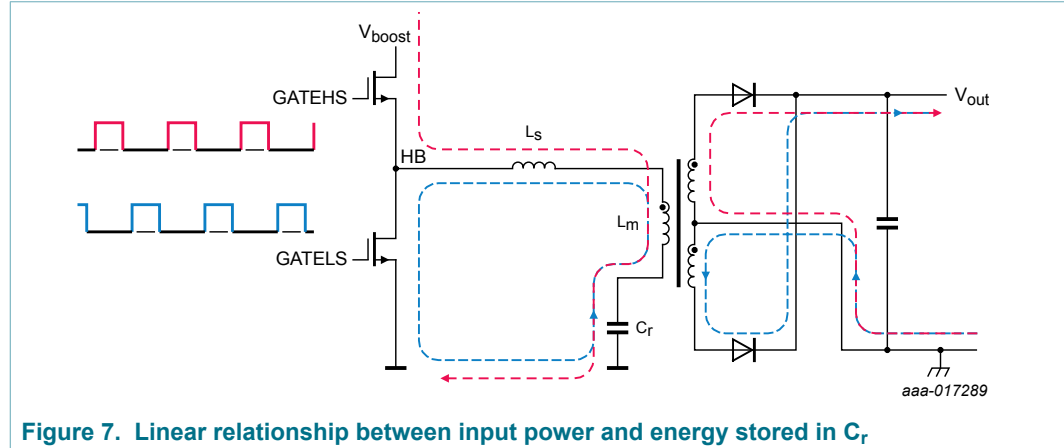

Figure 7. Linear relationship between input power and energy stored in C_r

When the high-side switch is on, a primary current is flowing through the transformer and resonant capacitor C_r as indicated by the red line. Half the energy the input delivers is transferred to the output. The other half charges resonant capacitor C_r . The voltage across the resonant capacitor increases.

When the high-side switch is off and the low-side switch is on, the energy which is stored in resonant capacitor C_r is transferred to the output and its voltage decreases. In this way, the linear relationship between the increase of the resonant capacitor voltage and the output power can be seen.

Although the TEA19161CT uses the primary capacitor voltage as a regulation parameter, all application values like the resonant inductances, resonant capacitor, and primary MOSFETs remain unchanged compared to a frequency controlled LLC converter. A secondary TL431 circuitry in combination with an optocoupler connected to the primary SNSFB pin continuously regulates the output voltage.

8.3.1 Output power regulation loop

Figure 8 shows the output power regulation loop of V_{cap} control as used by the TEA19161CT. Figure 9 shows a corresponding timing diagram.

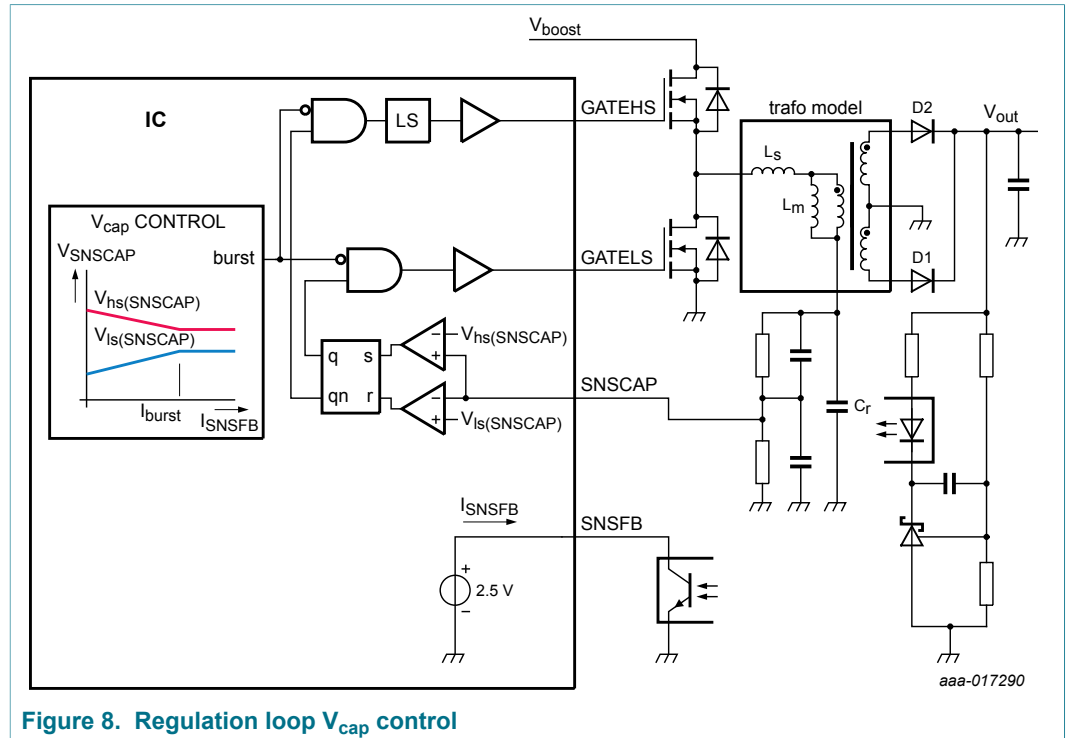

Figure 8. Regulation loop V_{cap} control

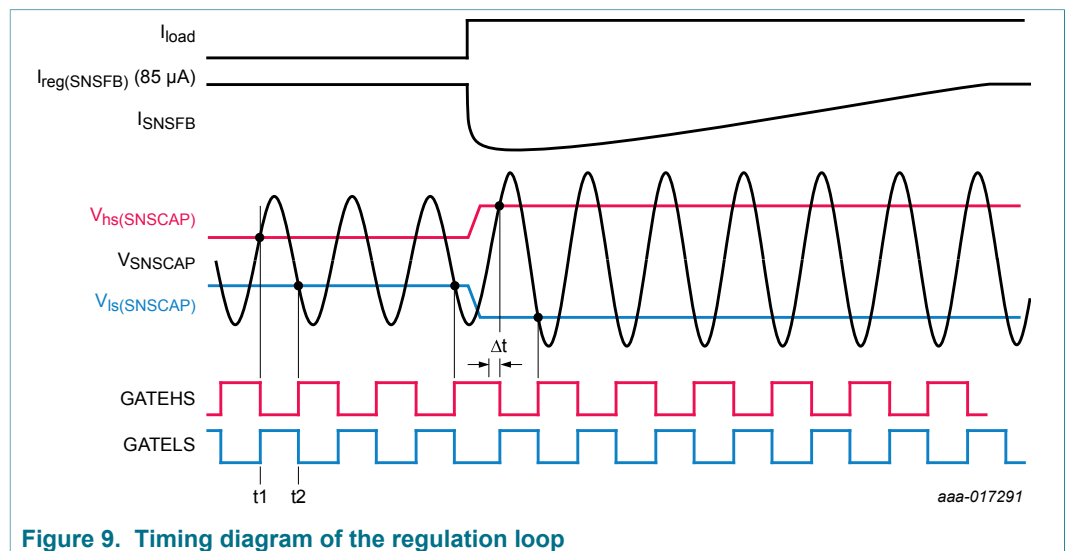

Figure 9. Timing diagram of the regulation loop

When the divided resonant capacitor voltage (V_{SNSCAP}) exceeds the capacitor voltage high level ($V_{hs(SNSCAP)}$), the high-side MOSFET is switched off (see Figure 9 (t1)). After a short delay, the low-side MOSFET is switched on. Because of the resonant current, the resonant capacitor voltage initially increases further but eventually drops.

When the divided capacitor voltage (V_{SNSCAP}) drops to below the capacitor voltage low level ($V_{\text{ls}(\text{SNSCAP})}$), the low-side MOSFET is switched off (see [Figure 9](#) (t2)). After a short delay, the high-side MOSFET is switched on. [Figure 9](#) shows that the switching frequency is a result of this switching behavior. In a frequency controlled system, the frequency is a control parameter and the output power is a result. The TEA19161CT regulates the power and the frequency is a result.

The difference between the high and low capacitor voltage level is a measure of the delivered output power. The value of the primary optocurrent, defined by the secondary TL431 circuitry, determines the difference between the high and low capacitor voltages.

[Figure 9](#) also shows the behavior at a transient. If the output load increases, the current pulled out of the SNSFB pin decreases. The result is that the TEA19161CT increases the high-level capacitor voltage and lowers the low-level capacitor voltage. According to [Equation 1](#), the output power increases and eventually the output voltage increases to its regulation level.

To minimize no-load input power of the system, the primary current into the optocoupler is continuously regulated to 85 μA (see [Section 8.5](#)).

8.3.2 Output voltage start-up

The system controls the output power by regulating the primary V_{Cr} (see [Section 8.3](#)). When the system is in regulation and the output voltage is stabilized, a small change in ΔV_{Cr} corresponds to a small change in the output current (see [Equation 2](#)).

$$P_{\text{out}} = V_{\text{out}} \times I_{\text{out}} \sim V_{\text{boost}} \times I_{\text{boost}} = \Delta V_{\text{Cr}} \times C_r \times f_{\text{sw}} \times V_{\text{boost}} \quad (2)$$

$$I_{\text{out}} \approx C_r \times f_{\text{sw}} \times V_{\text{boost}} \times \frac{\Delta V_{\text{Cr}}}{V_{\text{out}}}$$

However, before start-up, when the output voltage is around zero, a small capacitor voltage increase (ΔV_{Cr}) corresponds to a substantial output current increase. So, at start-up, the divided ΔV_{Cr} voltage (ΔV_{SNSCAP}) is slowly increased from a minimum value to the regulation level. As a result, the system starts up at a higher frequency. The GATELS resistor sets the starting value of the ΔV_{SNSCAP} .

8.4 Modes of operation

Figure 10 shows the control curve between the output power and the voltage difference between the high and low capacitor voltage levels.

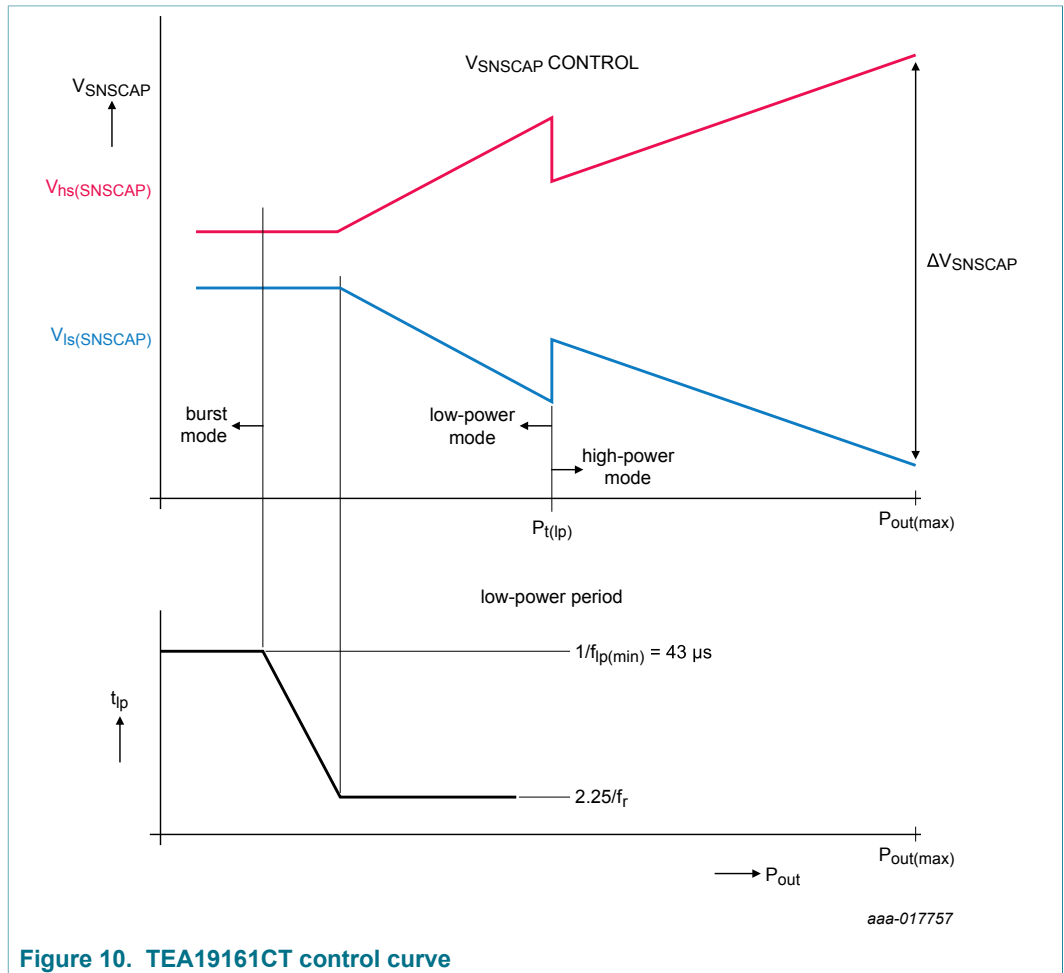

Figure 10. TEA19161CT control curve

When the output power (P_{out}) is at its maximum, the low capacitor voltage level ($V_{LS(SNSCAP)}$) is at its minimum and the high capacitor voltage ($V_{HS(SNSCAP)}$) is at its maximum level. According to Equation 1, the maximum ΔV_{SNSCAP} ($V_{HS(SNSCAP)} - V_{LS(SNSCAP)}$), which is the divided ΔV_{Cr} voltage, corresponds to the maximum output power.

When the output load decreases, the ΔV_{SNSCAP} voltage decreases. As a result, the output power decreases and the output voltage is regulated. This mode is called high-power mode.

When the output power drops to below the transition level ($P_{t(lp)}$), the system enters the low-power mode. External components can set the applied $P_{t(lp)}$ level (see Section 8.7.3).

To compensate for the hold period, ΔV_{SNSCAP} is initially increased at entering the low-power mode (see Section 8.4.2). In low-power mode, the output power is initially regulated by adapting ΔV_{SNSCAP} , until it reaches a minimum. Then, the output power is regulated by lowering the duty cycle of the low-power mode with a fixed ΔV_{SNSCAP} until the period time of a low-power cycle reaches a maximum ($1 / f_{lp(min)}$). The system then enters the burst mode (see Section 8.4.3).

8.4.1 High-power mode

In high-power mode, the system operates as described in Section 8.3.1. Figure 11 shows a flow diagram of the high-power mode.

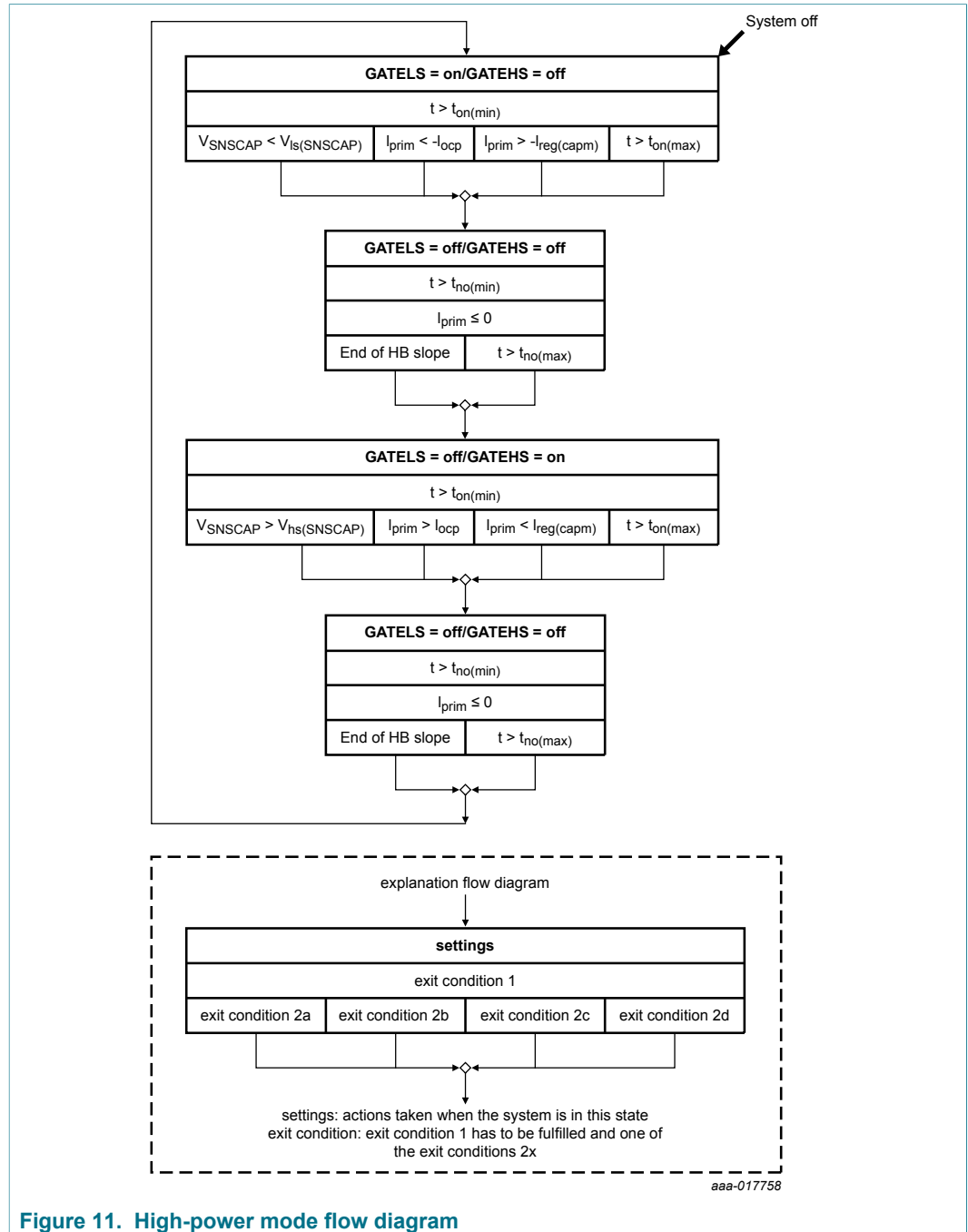

Figure 11. High-power mode flow diagram

When the system is off, GATELS is on and GATEHS is off. The external bootstrap buffer capacitor (C_{SUPHS}) is charged via the SUPREG pin and an external diode. The system remains in this state for at least the minimum on-time ($t_{on(min)}$) of GATELS. Before entering the next state, one of the following conditions must be fulfilled:

- The V_{SNSCAP} voltage drops to below the minimum V_{SNSCAP} voltage ($V_{IS(SNSCAP)}$)
- The measured current exceeds the OCP level (see [Section 8.6.6](#))
- The system is close to capacitive mode (see [Section 8.6.5](#))
- The maximum on-time ($t_{on(max)}$), a protection that maximizes the time the high-side or low-side MOSFET is kept on, is exceeded.

In the next state, to avoid false detection of the HB peak voltage, the system waits until the minimum non-overlap time ($t_{no(min)}$) is exceeded. When it is exceeded, the system starts to detect the end (= peak voltage) of the HB node. When it detects the peak of the HB node and the measured resonant current is negative (or zero), it enters the next state.

If the system does not detect a peak at the HB node, it also enters the next state when the maximum non-overlap time ($t_{no(max)}$) is exceeded under the condition of a negative (or zero) resonant current.

Finally, the third and fourth states (see [Figure 11](#)) describe the GATEHS and GATELS to GATELS transition criteria which are the inverse of the first two states.

8.4.2 Low-power mode

At low loads, the operating frequency of a resonant converter increases. As a result, the magnetization and switching losses increase. For this reason, the efficiency of a resonant converter drops at low loads. A newly introduced low-power mode ensures high efficiency at lower loads as well.

When the output power drops to below the $P_{t(lp)}$ level, the system enters the low-power mode (see [Figure 10](#) and [Figure 12](#)). It continues switching for 3 half-cycles (low-side, high-side, low-side) with a fixed duty cycle of 67 %. To ensure a constant output power level, it increases the energy per cycle ($V_{HS(SNSCAP)} - V_{IS(SNSCAP)}$) at the same time. So 1/3 of the time the converter is in a "hold" period. The result is a 33 % magnetization and switching losses reduction.

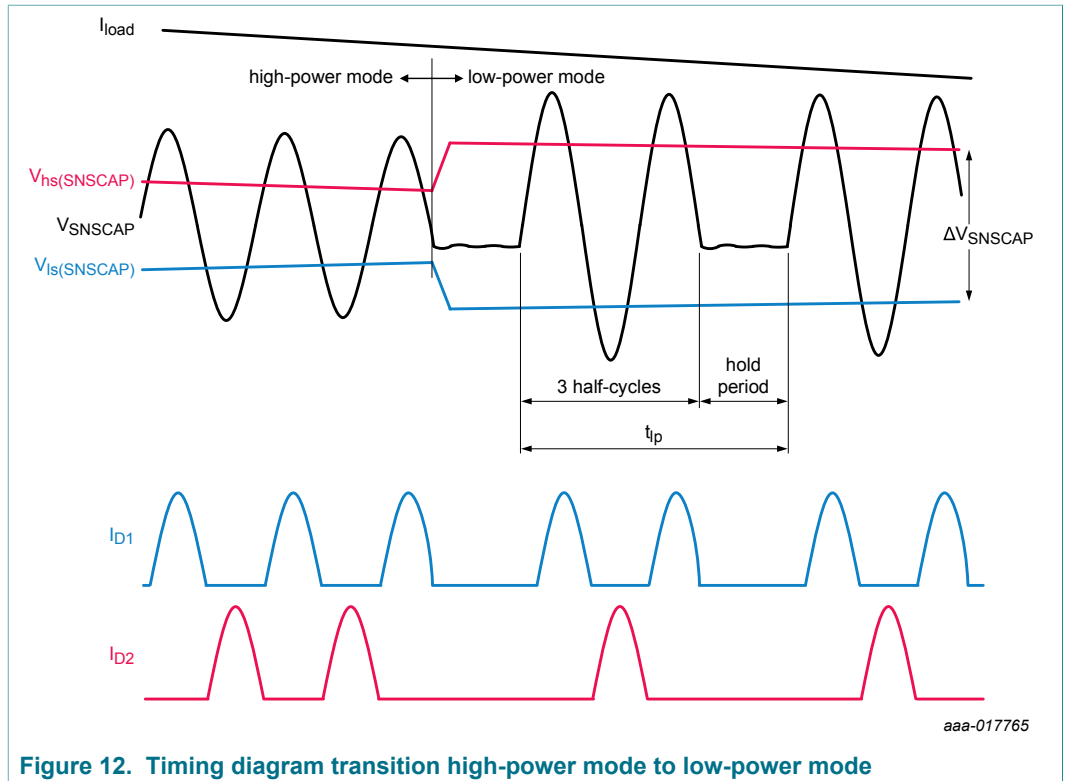

Figure 12. Timing diagram transition high-power mode to low-power mode

As the system continuously tracks the primary capacitor voltage, it knows exactly when to enter the "hold" period. It can also continue again at exactly the correct voltage and current levels of the resonant converter. In this way, a "hold" period can be introduced which reduces the magnetization and switching losses without any additional losses. The currents I_{D1} and I_{D2} (see [Figure 12](#)) are the secondary currents through diodes D1 and D2 (see [Figure 27](#)).

When in the low-power mode the output power is further reduced, the amount of energy per cycle ($= \Delta V_{SNSCAP}$) is reduced and the duty cycle remains the same (see [Figure 13](#)).

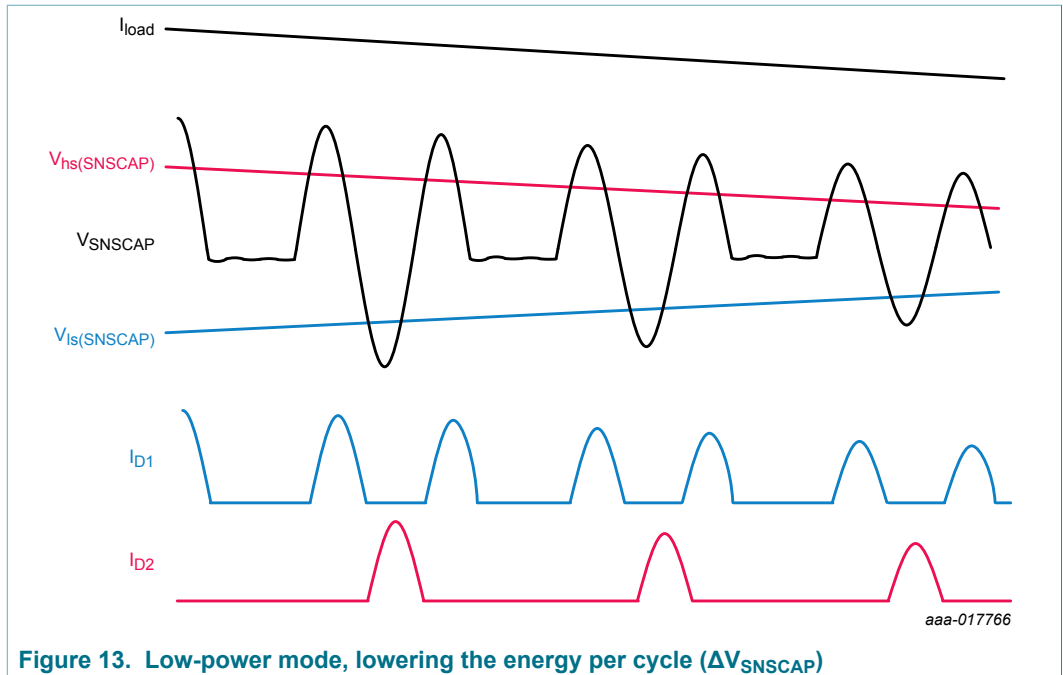

Figure 13. Low-power mode, lowering the energy per cycle (ΔV_{SNSCAP})

When, in low-power mode, the minimum energy per cycle is reached, the duty cycle regulates the output power (see Figure 14). Increasing the "hold" period lowers the duty cycle.

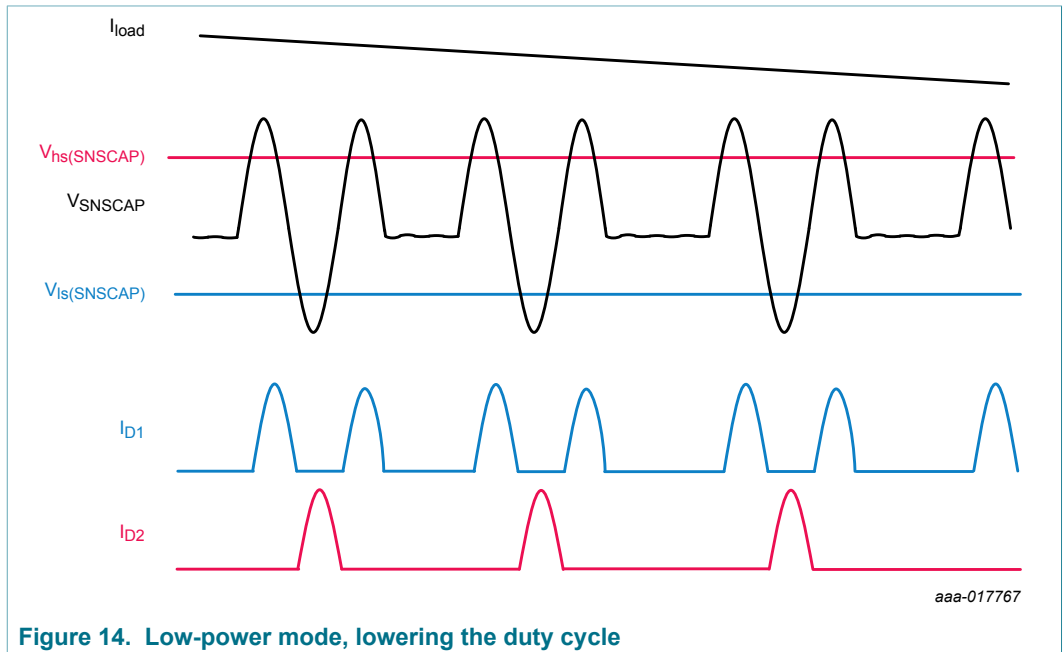

Figure 14. Low-power mode, lowering the duty cycle

To avoid audible noise, the system reduces the duty cycle until the frequency reaches $f_{ip(min)}$ (23 kHz). If the output power is lowered further, the system enters the burst mode.

8.4.3 Burst mode

In burst mode, the system alternates between operating in low-power mode and an extended hold state (see Figure 15). Because of this additional extended hold period, the magnetization and switching losses are further reduced. So, the efficiency of the system is increased.

Figure 15 shows that all operating frequencies are outside the audible area. The minimum low-power frequency is 23 kHz. Within a low-power period, the system is switching at the resonant frequency of the converter, which is typically between 50 kHz and 200 kHz.

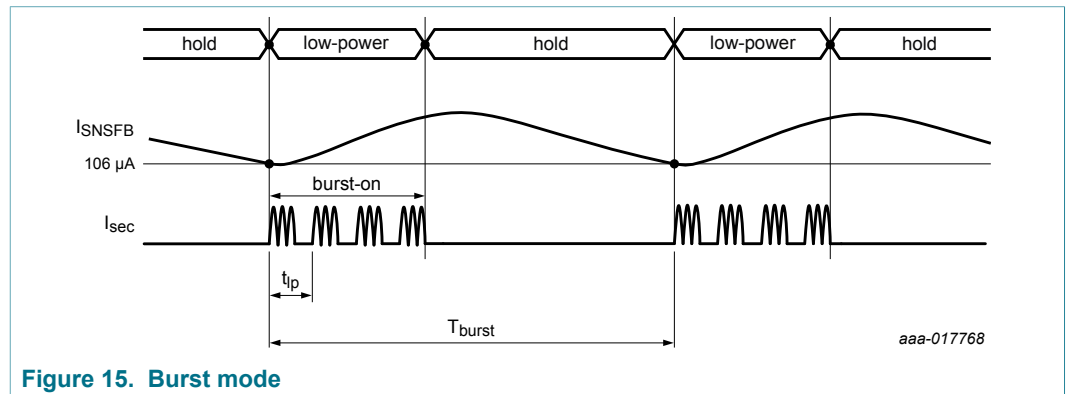

Figure 15. Burst mode

The burst frequency ($1 / t_{burst}$) is continuously regulated to a predefined value, which can be set externally to 200 Hz, 400 Hz, 800 Hz, or 1600 Hz. I_{sec} is the secondary current flowing through either diode D1 or D2 (see Figure 27).

When the primary optocurrent (I_{SNSFB}) drops to below 106 μA, a new burst-on period is started. The end of the burst-on period depends on the calculated number of low-power cycles. The number of low-power cycles within a burst-on is continuously adjusted so that the burst period is at least the period defined by the setting (see Figure 16).

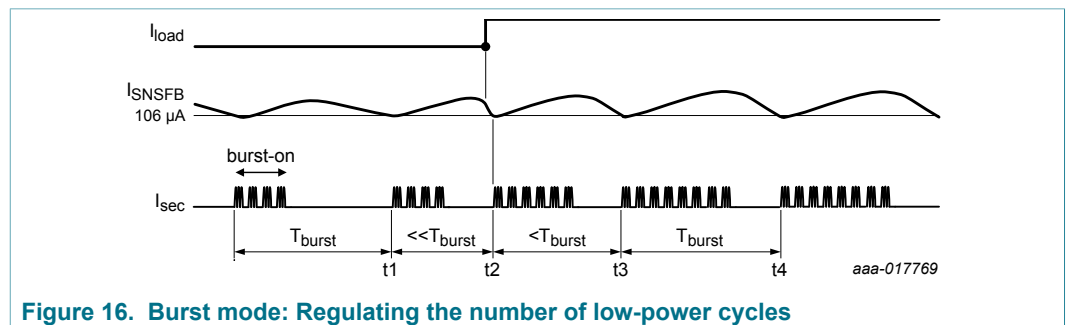

Figure 16. Burst mode: Regulating the number of low-power cycles

The system continuously measures the burst period from the start of the previous burst-on period to a new burst-on period. At t_1 , the measured burst period (T_{burst}) equals the required T_{burst} . So, the next number of low-power cycles equals the number of previous low-power cycles. At a constant output power, the system expects that when the next burst-on period has the same number of low-power cycles as the previous burst-on period, the burst period (t_{burst}) remains constant.

At a positive transient (t_2), a new low-power cycle is started immediately to minimize the drop in output voltage. The measured time period, at time t_2 , is below the targeted burst period. The system increases the number of burst cycles. At t_3 , it measures the burst

period again. In this example, the burst period is still below the targeted burst period. So, the system increases the number of low-power cycles again and again until the measured burst period equals the target burst period, which occurs at t_4 .

8.5 Optobias regulation

In a typical application, the output voltage is sensed using a TL431 and connected to the SNSFB pin of the TEA19161CT via an optocoupler (see Figure 27). Because of the behavior of the TL431, the current through the optocoupler is at the maximum level when the output power is at the minimum level. It is therefore one of the most critical parameters to achieve the required no-load input power. To achieve maximum efficiency at low load/no-load, the TEA19161CT continuously regulates the optocurrent to a low level that is independent of the output load.

A very low optocurrent reduces the transient response of the system, because of the parasitic capacitance at the optocoupler collector. So, the TEA19161CT applies a fixed voltage at the SNSFB pin. It measures the current through the optocoupler which defines the required output power. Via an additional internal circuitry, which adds an offset to the required output power, the optocurrent is continuously (slowly) regulated to the $I_{reg(SNSFB)}$ level ($= 85 \mu A$). This level is independent of the output power.

At a positive load transient, the optocurrent initially decreases (see Figure 9; I_{SNSFB}). The TEA19161CT immediately increases the ΔV_{SNSCAP} which again increases the output power.

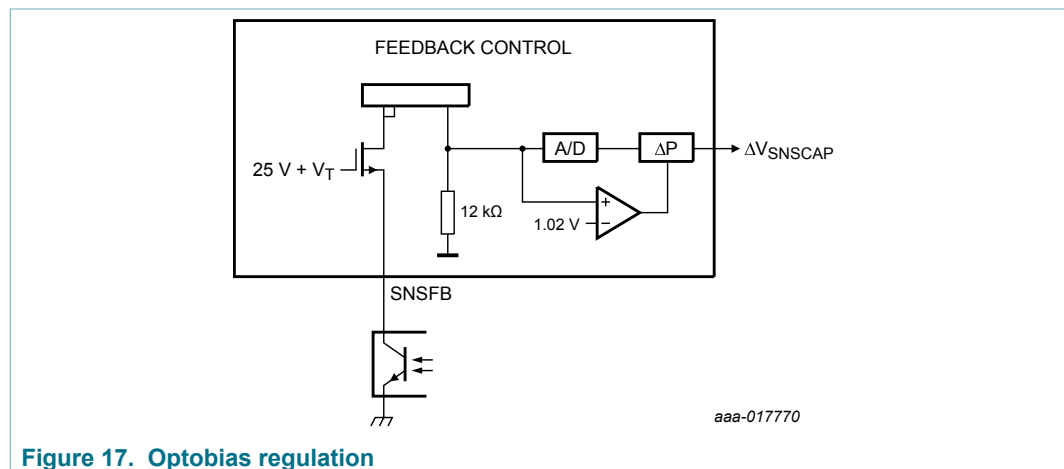

Figure 17. Optobias regulation

Figure 17 shows that when the optocurrent decreases, the internal voltage across the 12 kΩ resistor drops to below the targeted level of 1020 mV ($= 85 \mu A \times 12 \text{ k}\Omega$). The TEA19161CT then slowly increases an additional offset at the power level (ΔP). It continues to increase the additional offset until the optocurrent reaches the target of 85 μA . At a negative transient, the additional offset to the power level is decreased. As a result, the output voltage increases which again increases the optocurrent. In this way, the optocurrent is continuously regulated to the $I_{reg(SNSFB)}$ level (see Figure 9).

The behavior of the internal circuitry connected to the SNSFB pin is the same as the behavior of the traditional circuitry. The fixed voltage at the SNSFB pin and the continuous regulation of the optocurrent level does not influence the regulation level. The advantage, however, is a reduction in no-load input power and an optimization of the transient response.

When the system operates in low-power mode at the minimum energy/cycle and minimum duty cycle, it can no longer reduce the optocurrent level to the $I_{reg(SNSFB)}$ target ($\approx 85 \mu A$). If the output power decreases further and the optocurrent increases to above the level of $I_{start(burst)}$ ($\approx 106 \mu A$), the burst mode is triggered. When the output power drops to below this level again, a new burst cycle is started (see [Figure 15](#) and [Figure 16](#)).

8.6 Protections

[Table 4](#) gives an overview of the available protections.

Table 4. Protections overview

Protection	Description	Action	PFC
UVP SUPIC/ SUPREG	undervoltage protection SUPIC/ SUPREG pins	LLC = off; recharge via SUPHV; restart when $V_{SUPIC} > V_{start(SUPIC)}$ and $V_{SUPREG} > V_{start(SUPREG)}$	off
UVP SUPHS	undervoltage protection SUPHS pin	GATEHS = off	
UVP SNSBOOST	undervoltage protection boost	LLC = off; restart when $V_{SNSBOOST} > V_{start(SNSBOOST)}$	
OVP output	overvoltage protection output	safe restart after 5 consecutive cycles ^[1]	off
CMR	capacitive mode regulation	system ensures that mode of operation is inductive	
OCP	overcurrent protection	switch off cycle-by-cycle; safe restart after 5 consecutive cycles	off
OTP	overtemperature protection	safe restart	off
OPP	overpower protection	latched ^[2] /safe restart ^[3]	off

[1] Can be longer due to the sharing of the internal ADC converter.

[2] Latched implies that the system only restarts after a mains disconnection.

[3] Can be set by external components.

When the system is in a latched or safe restart protection, the SUPIC voltage is regulated to its start level via the SUPHV pin.

8.6.1 Undervoltage protection SUPIC/SUPREG

When the voltage on the SUPIC pin or the SUPREG pin is below its undervoltage level $V_{uVP(SUPIC)} / V_{uVP(SUPREG)}$, the LLC converter stops switching. The capacitors at the SUPIC and SUPREG pins are recharged via the SUPHV pin (see [Figure 5](#)). The SNSBOOST pin is pulled low, disabling the PFC. When the supply voltages exceed their start levels, the system restarts.

8.6.2 Undervoltage protection SUPHS

To ensure a minimum drive voltage at the high-side driver output (GATEHS), this driver is kept off when its voltage is below the minimum level ($V_{SUPHS} < V_{rst(SUPHS)}$).

8.6.3 Undervoltage protection boost

The PFC output voltage is measured via a resistive divider connected to the SNSBOOST pin. The voltage at the SNSBOOST pin must exceed the start level ($V_{\text{SNSBOOST}} > V_{\text{start(SNSBOOST)}}$) before the system is allowed to start switching.

When the system is operating and the voltage at the SNSBOOST pin drops to below the minimum level ($V_{\text{SNSBOOST}} < V_{\text{uvp(SNSBOOST)}}$), the LLC converter stops switching. When it exceeds the start level, it restarts.

8.6.4 Overvoltage protection

When the voltage at the SNSOUT pin exceeds the $V_{\text{ovp(SNSOUT)}}$ level for at least 5 consecutive switching cycles, the OVP protection is triggered. The voltage at the SNSOUT pin is internally measured via an ADC converter. As the same ADC converter toggles between measuring the SNSOUT and SNSBOOST pins (see [Figure 1](#)), there is an additional delay before the OVP is triggered. An OVP protection is followed by a safe restart. The safe restart implies that the system stops switching for a period $t_{\text{d(restart)}}$ (1 s), followed by a restart. The PFC is disabled via the SNSBOOST pin. The PFC is disabled via the SNSBOOST pin.

8.6.5 Capacitive mode regulation (CMR)

The TEA19161CT has a Capacitive Mode Regulation (CMR) which ensures that the system is always operating in inductive mode and avoids operation in capacitive mode.

At lower input voltage or higher output power and depending on the resonant design, the resonant current can already approach zero before the capacitor voltage reaches the regulation level.

When the resonant current has changed polarity before the switches are turned off and the other switch is turned on, hard switching occurs. This event is called capacitive mode. To avoid that the system operates in capacitive mode, the system also switches off the high-side/low-side switch when the resonant current approaches zero.

[Figure 18](#) shows the signals that occur when a resonant converter is switching in CMR mode. At t_1 (and also at t_3), the low-side switch is on while the resonant current approaches zero before V_{SNSCAP} reaches $V_{\text{ls(SNSCAP)}}$. At t_2 , the resonant current is also close to changing polarity while the divided capacitor voltage (V_{SNSCAP}) has not reached the $V_{\text{hs(SNSCAP)}}$ level yet. To avoid a turn-off of the high-side switch at a negative current or the low-side at a positive current, the system also turns off the high-side/low-side switch when the primary current approaches zero. So at t_2 , the high-side switch is turned off because the primary current is close to zero. At t_3 (and also at t_1), the low-side switch is turned off, although V_{SNSCAP} did not reach the regulation level ($V_{\text{ls(SNSCAP)}}$) yet. The primary current is measured via an external sense resistor connected to the SNSCUR pin. The capacitive mode protection levels are $V_{\text{reg(capm)}}$ (-100 mV and +100 mV, respectively).

In this mode, the amount of output power is reduced and the output voltage decreases.

The TEA19161CT does not enter a so-called "capacitive mode protection", but avoids this mode of operation.

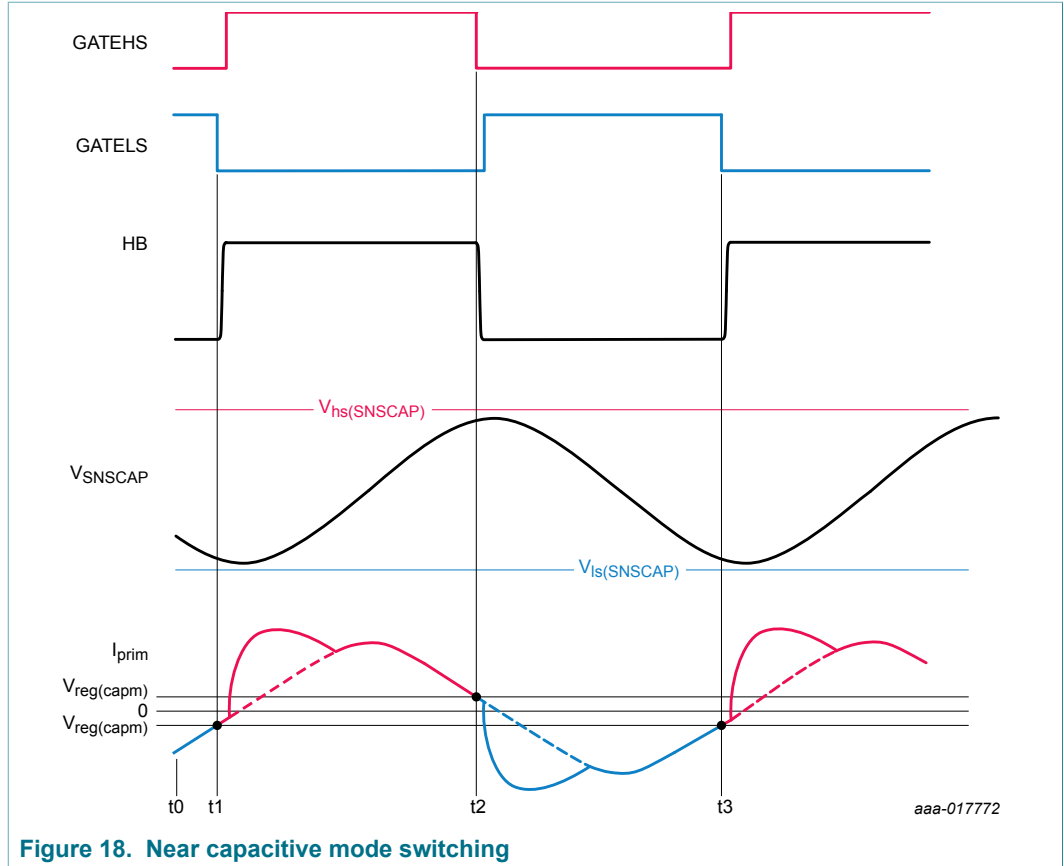

Figure 18. Near capacitive mode switching

8.6.6 Overcurrent protection

The system measures the primary current continuously via a sense resistor connected to the SNSCUR pin. If the measured voltage exceeds the overcurrent level (V_{ocp}), the corresponding switch (GATELS/GATEHS) is turned off, but the system continues switching. In this way, the primary current is limited to the OCP level. If the OCP level is exceeded for 5 consecutive cycles (GATELS and/or GATEHS), the system stops switching and restarts after $t_{d(restart)}$ (1 s). The PFC is disabled via the SNSBOOST pin.

8.6.7 Overtemperature protection

When the internal junction temperature exceeds the T_{otp} level, the overtemperature protection is triggered. OTP is a protection which also disables the PFC.

8.6.8 Overpower protection

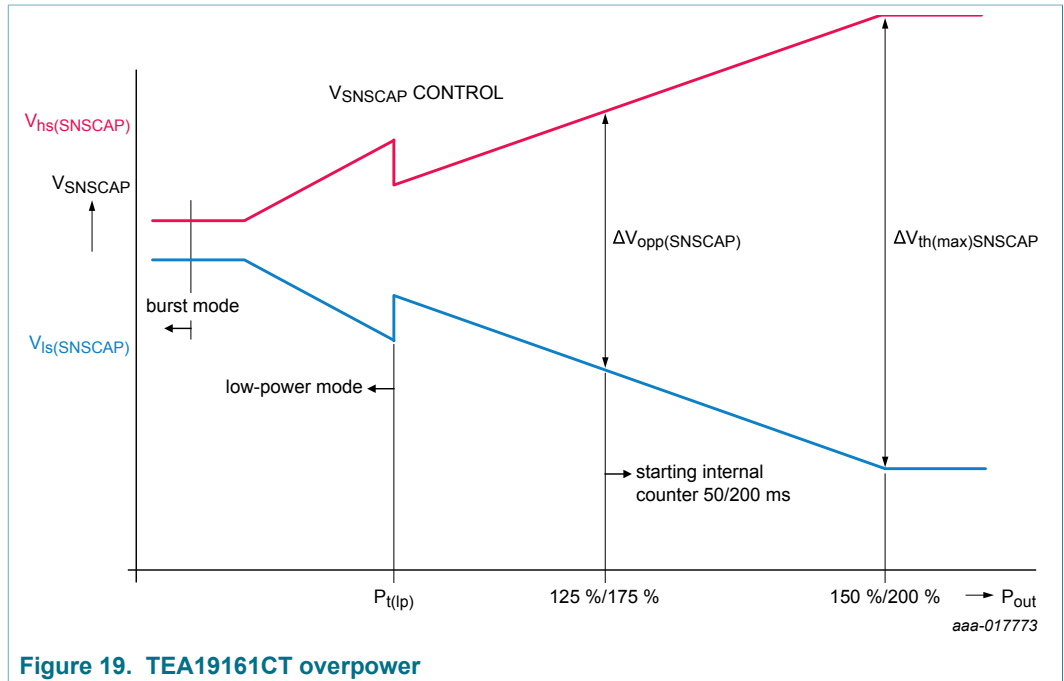

Figure 19. TEA19161CT overpower

The external capacitive/resistive divider connected to the SNSCAP pin must be chosen such that:

- The voltage difference between $V_{hs}(SNSCAP)$ and $V_{ls}(SNSCAP)$ equals $\Delta V_{opp}(SNSCAP)$
- The voltage difference between $V_{hs}(SNSCAP)$ and $V_{ls}(SNSCAP)$ occurs at 125 % of the maximum output power or at 175 %, depending on the settings

When the ΔV_{SNSCAP} ($V_{hs}(SNSCAP) - V_{ls}(SNSCAP)$) exceeds the $\Delta V_{opp}(SNSCAP)$ voltage difference, an internal counter is started. When this counter exceeds $t_{d(opp)}$ (50 ms/200 ms), the system enters a latched/safe restart protection as defined by the external settings.

The voltage difference between $V_{hs}(SNSCAP)$ and $V_{ls}(SNSCAP)$ is also limited to $\Delta V_{th(max)SNSCAP}$, which then corresponds to an output power of 150 % or 200 %, depending on the settings (see Figure 19). If the output of the LLC converter requires additional power, the output voltage drops as the power delivered by the LLC converter is limited to 150 % or 200 %.

An additional option is to disable the overpower counter, using the external settings. In this way, the overpower rating can be used as an extension of the typical power level.

8.7 External settings

Before the system starts switching, it reads the external settings. Using specific resistor values at the GATELS, SNSSET, and SNSOUT pins, several internal settings can be defined.

8.7.1 Burst period

Figure 20 shows how the internal regulated burst frequency can be set using the external resistor connected to the SNSOUT pin.

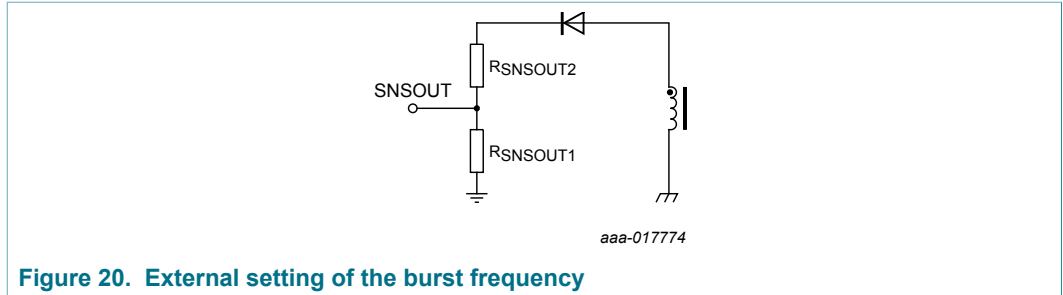

Figure 20. External setting of the burst frequency

Table 5. External setting of the burst frequency

$R_{SNSOUT1}$	Burst frequency
22 kΩ	200 Hz
15 kΩ	400 Hz
10 kΩ	800 Hz
6.8 kΩ	1600 Hz

The absolute value of the resistor connected between the SNSOUT pin and ground ($R_{SNSOUT1}$) defines the burst frequency. An accurate resistor of 1 % according to [Table 5](#) is required. The OVP level can be set using resistor $R_{SNSOUT2}$.

A low burst frequency is best for minimum audible noise. However, a high burst frequency minimizes the output voltage ripple.

8.7.2 General settings

Variables on the OPP function can be set using resistor $R_{SNSSET1}$ connected to the SNSSET pin (see [Figure 21](#)).

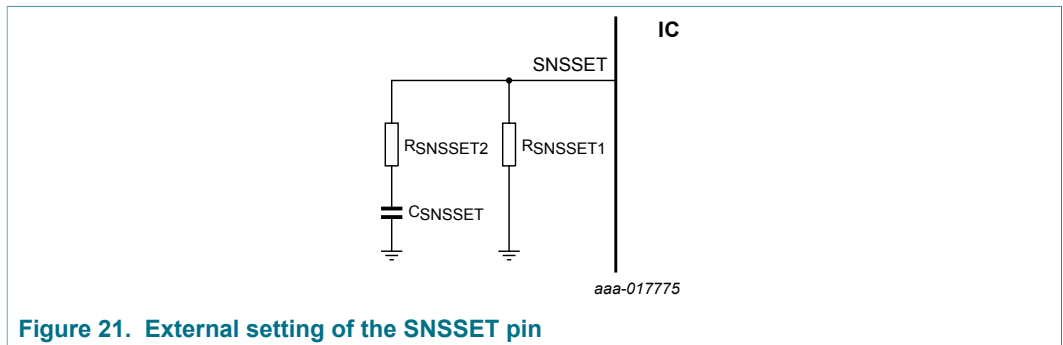

Figure 21. External setting of the SNSSET pin

Table 6. General settings

$R_{SNSSET1}$ (kΩ)	Power capability level (%)	OPP timer level (%)	End of power good timer (ms)	OPP timer (ms)	Protection
< 10		no start-up			
46.4	200	infinite			
53.6	200	175	190	200	1 s restart

$R_{SNSSET1}$ (k Ω)	Power capability level (%)	OPP timer level (%)	End of power good timer (ms)	OPP timer (ms)	Protection
61.9	200	175	45	50	1 s restart
71.5	150	125	190	200	1 s restart
82.5	150	125	45	50	1 s restart
95.3	200	175	190	200	latched
110	200	175	45	50	latched
127	150	125	190	200	latched
147	150	125	45	50	latched

When the measured value of $R_{SNSSET1} < 10$ k Ω , the system assumes a shorted pin to ground and the start-up is inhibited. At a value of 46.4 k Ω , the system can continuously deliver the maximum power of 200 %.

The output power level at which the overpower timer is started can be set to 125 % or 175 %. Two corresponding timer values can be selected, 50 ms or 200 ms. Finally, the value of $R_{SNSSET1}$ (see [Table 6](#)) can set the behavior of the overpower function (either a 1 s restart or latched). During this protection period, the SUPIC is regulated at its $V_{start(SUPIC)}$ level.

8.7.3 Low-power mode/burst mode transition levels

To ensure the best efficiency, the system must enter the low-power mode and the burst mode at high power levels. However, to ensure the best output ripple, these modes must be entered at low-power levels. To choose the optimum level for a specific application, the power transition levels at which the system enters the low-power mode and the burst mode can be set externally.

Resistor $R_{SNSSET2}$ defines the power levels at which the system enters the low-power mode and the burst mode. [Table 7](#) gives an overview.

Table 7. External setting of the high-power/low-power and low-power/burst transition

R _{SNSSET2} (kΩ)	High-power → low-power (%) ^[1]	Burst mode ^[1]			
		200 Hz (%)	400 Hz (%)	800 Hz (%)	1600 Hz (%)
1	25	9	9	9	9
6.8	25	12	12	12	12
15	37.5	9	9	9	10
27	37.5	12	12	12	13
47	50	9	10	11	12
82	50	12	13	15	17
180	62.5	9	10	12	14
open	62.5	12	15	17.5	20

[1] The values in this table are including the additional shift due to the internal (t_{PD(SNSCAP)}) delay and a typical external delay of 150 ns and 300 ns, respectively. When an external R + C network compensates these delays, the levels in Table 7 can be lowered.

The power level at which the system enters the burst mode also depends on the defined burst period. In this way, the optimum between efficiency and output voltage ripple can be chosen.

8.8 Power good function

The TEA19161CT provides a power good function via the SNSSET pin. At initialization, the TEA19161CT measures the resistors connected to the SNSSET pin to set internal variables. After that, the pin is used for the power good function.

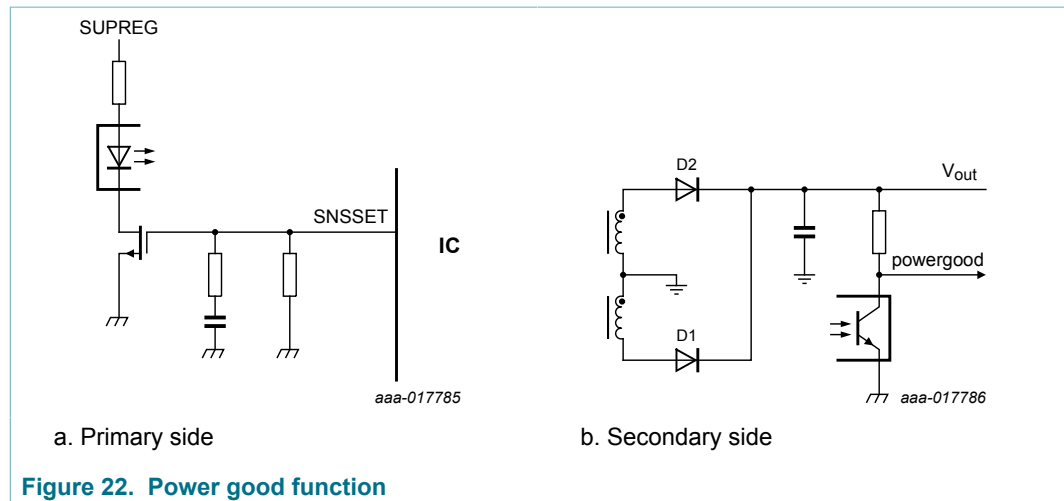

Figure 22. Power good function

After the system has read the external settings (see Figure 5), the SNSSET output is active high, enabling an external MOSFET. A secondary power good signal can be pulled low using an external optocoupler.

When the system enters the operating state (see Figure 5), the SNSSET output is pulled low and the external power good signal becomes active high. Any required delay can be achieved via an external R/C network.

At low power good, the SNSSET output becomes active high when:

- The voltage on the SNSBOOST pin drops to below $V_{\text{det(SNSBOOST)}}$ (1.95 V)
- The OPP counter is at a value indicated in [Table 6](#).

In this way, the secondary power good signal is pulled low at 5 ms or 10 ms before the output is disabled.

When the system enters protection mode (OVP, OCP, UVP, or OTP), it pulls low the SNSSET pin and stops switching immediately.

8.9 PFC/LLC communication protocol

The TEA19161CT is designed to cooperate with the TEA19162CT (PFC) in one system. The TEA19161CT and TEA19162CT can be seen as a combination, split up into two packages. All required functionality between the two controllers is arranged via the combined SUPIC and SNSBOOST pins.

8.9.1 Start-up

To ensure that at start-up the TEA19161CT and TEA19162CT are enabled at the same time, the TEA19161CT (LLC) pulls down the SNSBOOST pin to below the SNSBOOST short protection level of the PFC. The TEA19161CT disables the TEA19162CT (PFC) (see [Figure 23](#)) until the system enters the PFC start-up phase (see [Figure 5](#) and [Figure 23](#)).

The SUPIC start levels and stop levels of the TEA19162CT (PFC) are below the SUPIC start levels and stop levels of the TEA19161CT (LLC). When the SUPIC exceeds the start level of the TEA19161CT, both controllers are enabled.

In this way, both controllers are enabled/disabled at the same SUPIC start and stop levels.

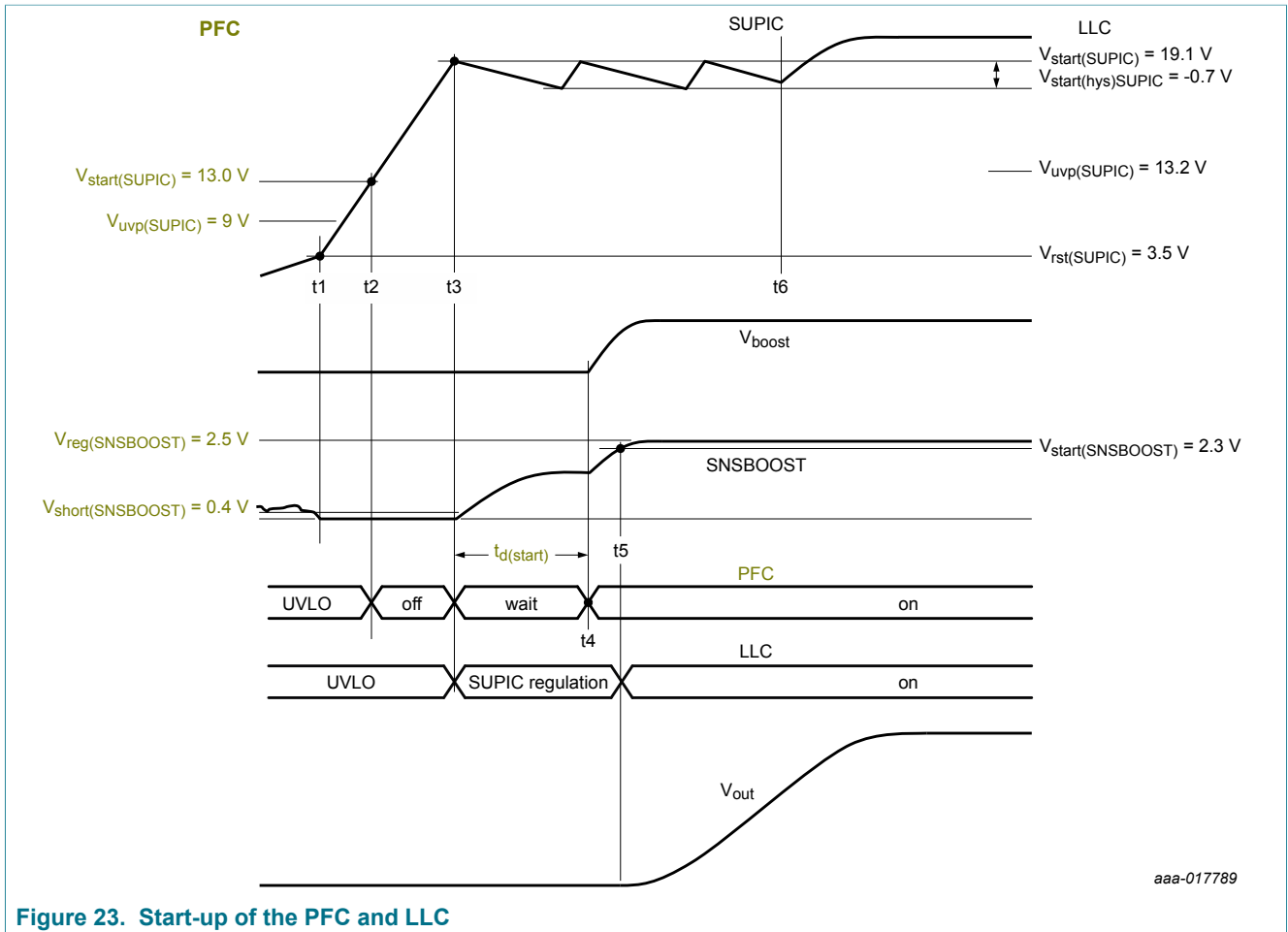

Figure 23. Start-up of the PFC and LLC

When the LLC reaches a minimum supply voltage level ($V_{rst(SUPIC)}$; t1), the LLC pulls down the SNSBOOST pin to disable the PFC.

At t2, the SUPIC reaches the start level of the PFC converter. However, as the LLC pulls low the SNSBOOST voltage to < the PFC short protection level, the PFC is still off. When at t3 the SUPIC reaches the start level of the LLC, after the LLC has read out the external settings, the SNSBOOST is released. It increases because of the connected resistive divider which is connected to the PFC boost voltage. To ensure that the SNSBOOST voltage is a representative of the V_{boost} voltage before the system actually starts to switch, an additional delay (until t4) is built into the PFC controller before it starts.

When at t5 the SNSBOOST voltage reaches the start level of the LLC, the LLC converter starts to switch. At t6, the SUPIC is supplied via the primary auxiliary winding.

8.9.2 Protection

When a protection is triggered in either the PFC or LLC, it may also disable the other converter. For example, if an OVP is detected at the LLC, both converters are latched. Also, at initial start-up, the PFC disables the LLC converter until the mains voltage detects the brownin level.

The PFC can disable the LLC converter by pulling down the SNSBOOST pin to below the $V_{uvp(SNSBOOST)}$ level of the LLC converter. The LLC can disable the PFC converter by

pulling down the SNSBOOST pin to below the short protection level of the PFC converter SNSBOOST pin.

Table 4 in Section 8.6 gives an overview of protections in the LLC converter. It shows which protections also disable the PFC.

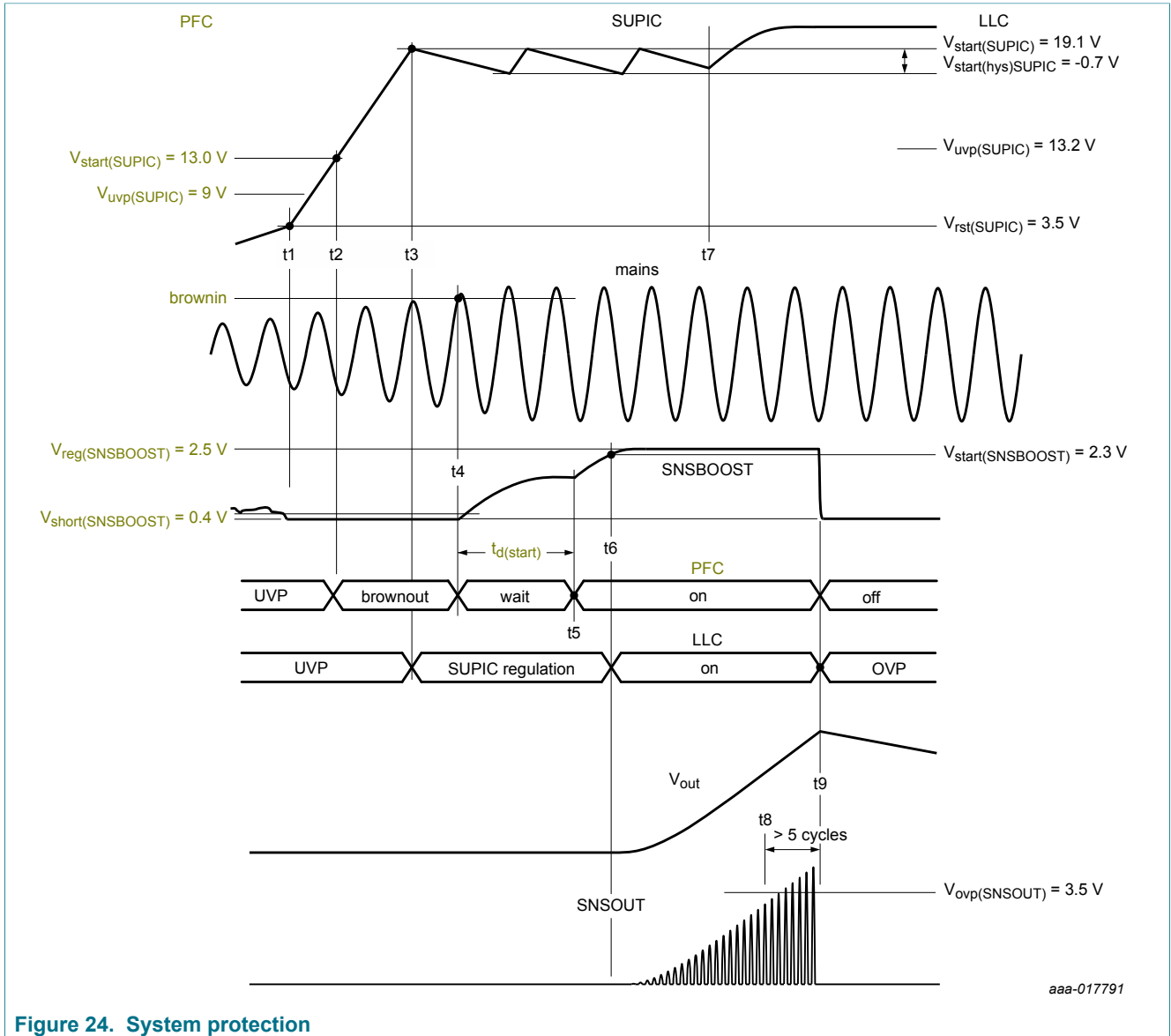

Figure 24. System protection

The start-up period up to t3 is identical in Figure 23 and Figure 24. At t3, the LLC converter releases the pull-down of the SNSBOOST pin. However, as the mains voltage is below the brownin level, the PFC converter pulls low the SNSBOOST pin. When the mains voltage exceeds the brownin level (t4), the SNSBOOST pin is released and increases because of the resistive divider connected between the PFC boost voltage and the SNSBOOST pin. To allow some external capacitance on the SNSBOOST pin, the PFC converter waits until the SNSBOOST voltage is stabilized.

At t5, the PFC converter starts to switch. At t6, the LLC converter also starts to switch, as the SNSBOOST voltage reaches the V_start(SNSBOOST) of the LLC converter.

At t7, the primary auxiliary winding takes over the supply of the SUPIC pin.

At t8, the LLC detects an OVP at the SNSOUT pin. After at least 5 consecutive OVP cycles (t9), the LLC stops switching and pulls down the SNSBOOST pin. As a result, the PFC also stops switching.

When either the PFC or LLC is in protection, the SUPIC pin is regulated to the $V_{start(SUPIC)}$ via the SUPHV pin as soon as it drops below the $V_{start(SUPIC)}$ level.

8.9.3 Fast latch reset

The SUPIC pin is regulated to the $V_{start(SUPIC)}$ level when a (latched) protection is triggered. So, it can remain in this protection mode until the capacitor at the PFC output, which the SUPHV is connected to, is discharged. Hence, it may remain in protection mode for a long time after the mains is disconnected.

When protection modes are tested at mass-production, a long reset time is not acceptable in most cases. So, a fast latch reset function is built into the PFC and the LLC. When the mains is initially disconnected and then reconnected, all protections the PFC or the LLC initiated are released again.

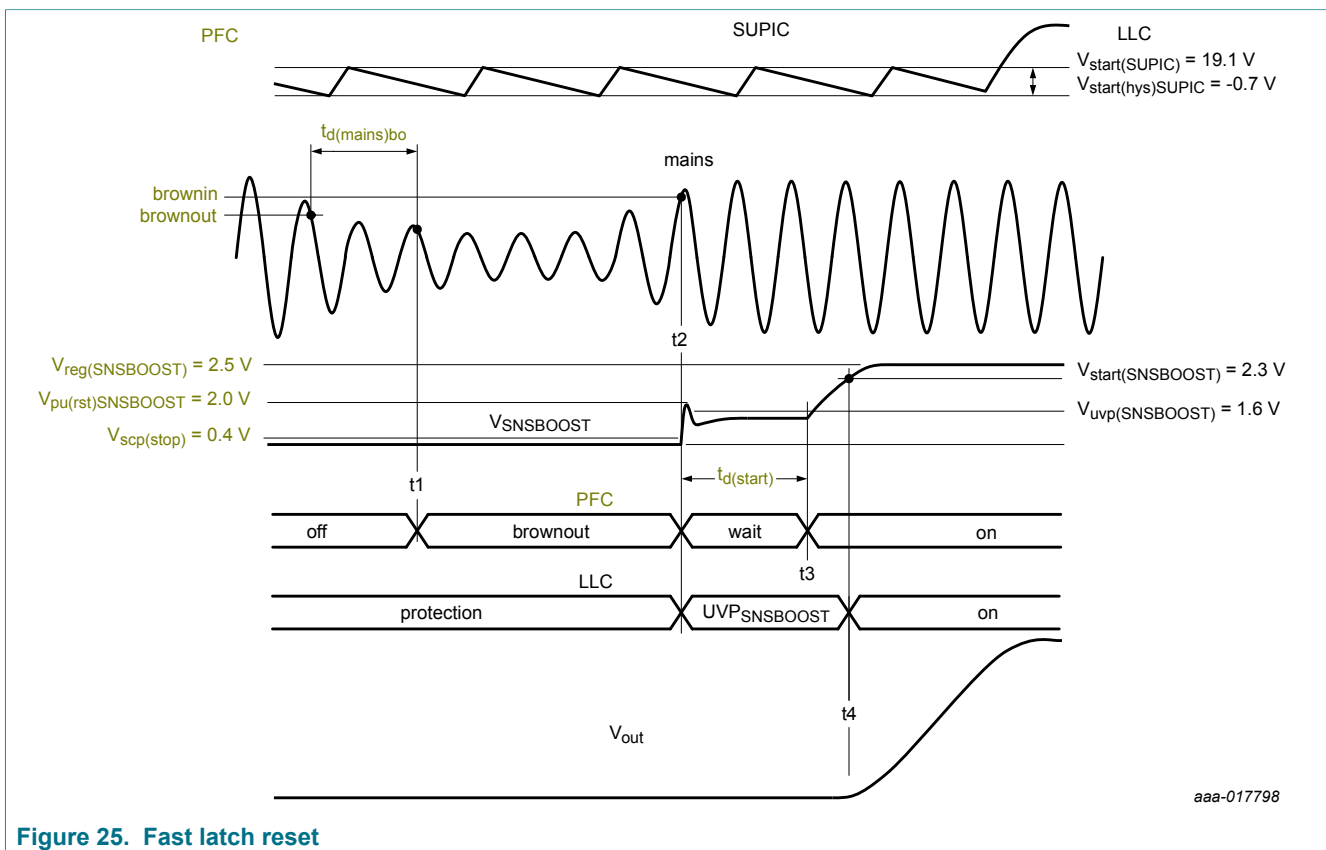

Figure 25. Fast latch reset

Before t1, the LLC is in a (latched) protection and pulls down the SNSBOOST pin, which also disables the PFC.

When the mains voltage drops to below the brownout level for a minimum period of $t_{d(mains)bo}$, the PFC enters the brownout protection mode. When, in the brownout protection mode, the mains voltage increases again to > the brownin level (t2), the PFC pulls up the SNSBOOST voltage until it reaches the $V_{uvp(SNSBOOST)}$ level of the LLC

converter. The LLC converter then releases all protection modes and waits until the SNSBOOST pin exceeds its start level ($V_{start(SNSBOOST)}$). After a waiting time, the PFC converter starts (t_3), followed by a start-up of the LLC converter (t_4).

8.9.4 PFC burst mode

When the LLC operates in burst mode and the duty cycle of the burst is below 50 % for at least 8 consecutive burst periods, the TEA19161CT (LLC) sets the TEA19162CT (PFC) in burst mode as well. The corresponding output power level is then 50 % of the power level at which the LLC enters the burst mode (see Table 7).

When the output power exceeds 75 % of the power level at which the LLC enters the burst mode (see Table 7), the PFC burst is disabled again.

When the PFC burst is enabled, an additional current out of the SNSBOOST pin stops the PFC from switching via a soft stop, so the audible noise is minimized (see Figure 24).

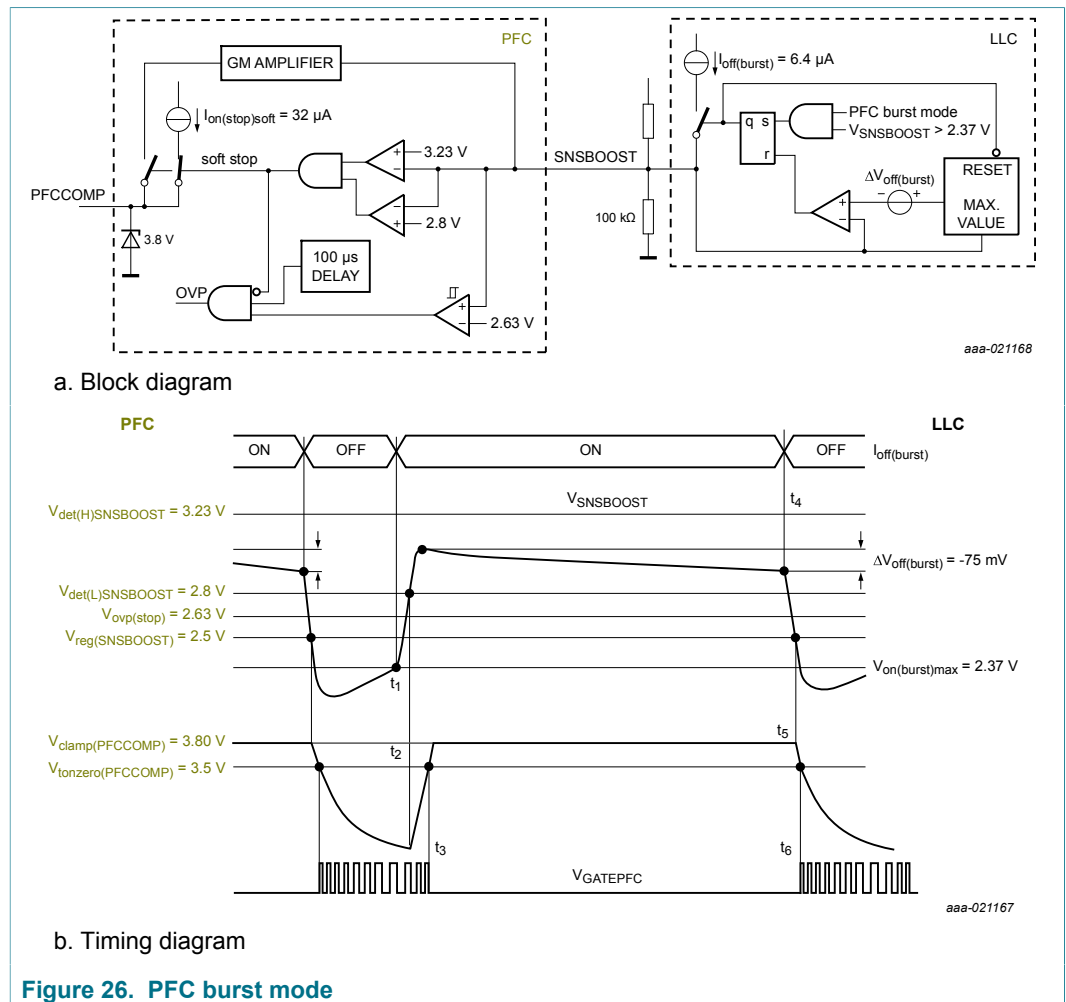

Figure 26. PFC burst mode

At t_1 , the current out of the LLC SNSBOOST pin ($I_{off(burst)}$) is activated and the voltage on the SNSBOOST pin increases. When an external 100 kΩ resistor ($R_{SNSBOOST}$) is used between the SNSBOOST pin and GND pin (see Figure 27), the SNSBOOST voltage increase is approximately 640 mV ($= I_{off(burst)} * R_{SNSBOOST}$). Because of this increase, the SNSBOOST voltage is between the $V_{det(L)SNSBOOST}$ and $V_{det(H)SNSBOOST}$ levels of the

PFC (t2), so the soft stop of the PFC converter is started. At the end of the soft stop, the PFC enters the energy safe state and stops switching (t3). Because of the continuous operation of the LLC converter, even when the PFC is stopped, the PFC output capacitor is discharged.

When the PFC boost capacitor is discharged so much that the voltage on the SNSBOOST pin has dropped 75 mV ($\Delta V_{\text{off(burst)}}$; t4), the internal current source in the LLC converter is switched off. Because of the negative voltage drop at the SNSBOOST pin, the PFC starts switching again. When V_{SNSBOOST} exceeds the LLC $V_{\text{on(burst)max}}$ level (2.37 V) again, the internal current source is reactivated and the PFC stops switching again (t1).

9 Limiting values

Table 8. Limiting values

In accordance with the Absolute Maximum Rating System (IEC 60134).

Symbol	Parameter	Conditions	Min	Max	Unit
Voltages					
V _{SUPHV}	voltage on pin SUPHV	maximum during mains surge; not repetitive	-0.4	+700	V
V _{SUPHS}	voltage on pin SUPHS		V _{HB}	V _{HB} + 14	V
V _{HB}	voltage on pin HB	maximum during mains surge; not repetitive	-3	+700	V
		t < 1 μs	-14	-	V
V _{SUPIC}	voltage on pin SUPIC		-0.4	+36	V
V _{SUPREG}	voltage on pin SUPREG		-0.4	+12	V
V _{GATEHS}	voltage on pin GATEHS		V _{HB} - 0.4	V _{SUPHS} + 0.4	V
V _{GATELS}	voltage on pin GATELS		-0.4	V _{SUPREG} + 0.4	V
V _{SNSFB}	voltage on pin SNSFB		-0.4	+12	V
V _{SNSOUT}	voltage on pin SNSOUT		-0.4	+12	V
V _{SNSSET}	voltage on pin SNSSET		-0.4	+12	V
V _{SNSCUR}	voltage on pin SNSCUR		-0.4	+12	V
V _{SNSCAP}	voltage on pin SNSCAP		-0.4	+12	V
V _{SNSBOOST}	voltage on pin SNSBOOST		-0.4	+12	V
Currents					
I _{SUPHV}	current on pin SUPHV		-	20	mA
General					
P _{tot}	total power dissipation	T _{amb} < 75 °C	-	0.7	W
T _{stg}	storage temperature		-55	+150	°C
T _j	junction temperature		-40	+150	°C
Latch-up					
I _{lu}	latch-up current	all pins; according to JEDEC: Standard 78D	-100	+100	mA
ElectroStatic Discharge (ESD)					
V _{ESD}	electrostatic discharge voltage	human body model			
		pins SUPHV, SUPHS, GATEHS, and HB	-1000	+1000	V
		other pins	-2000	+2000	V
		charged device model; all pins	-500	+500	V

10 Thermal characteristics

Table 9. Thermal characteristics

Symbol	Parameter	Conditions	Typ	Unit
$R_{th(j-a)}$	thermal resistance from junction ambient	In free air; JEDEC test board	107	K/W
$R_{th(j-c)}$	thermal resistance from junction to case	In free air; JEDEC test board	60	K/W

11 Characteristics

Table 10. Characteristics

$T_{amb} = 25\text{ °C}$; $V_{SUPIC} = 19.5\text{ V}$; all voltages are measured with respect to GND; currents are positive when flowing into the IC; unless otherwise specified.

Symbol	Parameter	Conditions	Min	Typ	Max	Unit
SUPHV pin						
$I_{lim(SUPHV)}$	current limit on pin SUPHV	$V_{SUPIC} < V_{rst(SUPIC)}$	0.5	0.75	1.0	mA
$I_{off(SUPHV)}$	off-state current on pin SUPHV	$V_{SUPIC} = 15\text{ V}$	-	0.5	0.9	μA
$\Delta V_{I(SUPHV-SUPIC)}$	input voltage difference between pin SUPHV and pin SUPIC	$I_{SUPHV} = 20\text{ mA}$	-	7	-	V
SUPIC pin						
$V_{start(SUPIC)}$	start voltage on pin SUPIC		18.3	19.1	19.8	V
$V_{start(hys)SUPIC}$	start voltage hysteresis on pin SUPIC		-	-0.7	-	V
$V_{low(hys)SUPIC}$	start voltage hysteresis on pin SUPIC		-	0.9	-	V
$V_{low(SUPIC)}$	low voltage on pin SUPIC	$V_{uvp(SUPIC)} = 13.3\text{ V}$; tracks with $V_{uvp(SUPIC)}$	-	14.0	-	V
$V_{uvp(SUPIC)}$	undervoltage protection voltage on pin SUPIC		12.7	13.2	13.7	V
$V_{rst(SUPIC)}$	reset voltage on pin SUPIC		-	3.5	-	V
$I_{CC(SUPIC)}$	supply current on pin SUPIC	operating mode; $f_{HB} = 100\text{ kHz}$; GATEHS/GATELS open; $I_{SNSFB} = -85\text{ }\mu\text{A}$; $I_{SNSCAP} = -100\text{ }\mu\text{A}$	-	5.6	-	mA
		latched protection; $I_{SNSFB} = 0\text{ }\mu\text{A}$; $I_{SNSCAP} = -100\text{ }\mu\text{A}$	2.3	3.0	3.7	mA
		burst mode; $I_{SNSFB} = -106\text{ }\mu\text{A}$; $I_{SNSCAP} = -100\text{ }\mu\text{A}$	-	0.7	-	mA

Symbol	Parameter	Conditions	Min	Typ	Max	Unit
SUPREG pin						
$V_{\text{intregd(SUPREG)}}$	internal regulated voltage on pin SUPREG	$V_{\text{SUPIC}} > 13.8 \text{ V}; I_{\text{SUPREG}} = 50 \text{ mA}$	10.6	11.0	11.4	V
$V_{\text{reg(acc)SUPREG}}$	regulator voltage accuracy on pin SUPREG	$V_{\text{SUPIC}} > 13.8 \text{ V}; 10 \mu\text{A} < I_{\text{SUPREG}} < 20 \text{ mA}$	-150	-100	-50	mV
$I_{\text{lim(SUPREG)}}$	current limit on pin SUPREG	$V_{\text{SUPIC}} = 19.5 \text{ V}$	-44	-37	-30	mA
$V_{\text{uvp(SUPREG)}}$	undervoltage protection voltage on pin SUPREG		8.6	9.0	9.4	V
SNSCAP pin						
$V_{\text{AV(regd)SNSCAP}}$	regulated average voltage on pin SNSCAP	regulated average of $V_{\text{hs(SNSCAP)}}$ and $V_{\text{ls(SNSCAP)}}$	-	2.50	-	V
$I_{\text{bias(max)SNSCAP}}$	maximum bias current on pin SNSCAP		-245	-210	-175	μA
$\Delta V_{\text{th(max)SNSCAP}}$	maximum threshold voltage difference on pin SNSCAP	$V_{\text{hs(SNSCAP)}} - V_{\text{ls(SNSCAP)}; P_{\text{out}} = 200 \%; V_{\text{SNSBOOST}} = 2.5 \text{ V}$	-	1.92	-	V
		$V_{\text{hs(SNSCAP)}} - V_{\text{ls9(SNSCAP)}; P_{\text{out}} = 200 \%; V_{\text{SNSBOOST}} < 2.0 \text{ V}$	2.85	3.00	3.15	V
Overpower protection						
$\Delta V_{\text{opp(SNSCAP)}}$	overpower protection voltage difference on pin SNSCAP	$V_{\text{hs(SNSCAP)}} - V_{\text{ls(SNSCAP)}; P_{\text{out}} = 150 \%; V_{\text{SNSBOOST}} = 2.5 \text{ V}$	-	1.44	-	V
		$V_{\text{hs(SNSCAP)}} - V_{\text{ls(SNSCAP)}; P_{\text{out}} = 150 \%; V_{\text{SNSBOOST}} = 2.1 \text{ V}$	-	2.24	-	V
$t_{\text{PD(SNSCAP)}}$	propagation delay on pin SNSCAP	from crossing $V_{\text{ls(SNSCAP)}/V_{\text{hs(SNSCAP)}}$ level to GATELS/GATEHS switch-off	-	150	-	ns
$t_{\text{d(opp)}}$	overpower protection delay time	See Table 6 for related R_{SNSSET1}	40	50	60	ms
		See Table 6 for related R_{SNSSET1}	160	170	180	ms
$t_{\text{d(restart)}}$	restart delay time		0.8	1.0	1.2	s
SNSCUR pin						
$V_{\text{bias(SNSCUR)}}$	bias voltage on pin SNSCUR		2.4	2.5	2.6	V
$R_{\text{O(SNSCUR)}}$	output resistance on pin SNSCUR		-	60	-	k Ω
V_{occ}	overcurrent protection voltage	positive level; $V_{\text{SNSCUR}} - V_{\text{bias(SNSCUR)}}$	1.35	1.50	1.65	V
		negative level; $V_{\text{SNSCUR}} - V_{\text{bias(SNSCUR)}}$	-1.65	-1.50	-1.35	V
$V_{\text{reg(capm)}}$	capacitive mode regulation voltage	positive level; $V_{\text{SNSCUR}} - V_{\text{bias(SNSCUR)}}$	85	100	115	mV
		negative level; $V_{\text{SNSCUR}} - V_{\text{bias(SNSCUR)}}$	-115	-100	-85	mV

Symbol	Parameter	Conditions	Min	Typ	Max	Unit
$V_{\text{det(zero)}}$	zero detection voltage	detected as ≥ 0	-	-13	-	mV
		detected as ≤ 0	-	13	-	mV
SNSBOOST pin						
$V_{\text{start(SNSBOOST)}}$	start voltage on pin SNSBOOST		2.2	2.3	2.4	V
$V_{\text{uvp(SNSBOOST)}}$	undervoltage protection voltage on pin SNSBOOST		1.5	1.6	1.7	V
$V_{\text{det(SNSBOOST)}}$	detection voltage on pin SNSBOOST	when below power good = LOW	-	1.95	-	V
PFC burst mode controller						
$\bar{d}_{\text{en(burst)}}$	burst mode enable duty cycle	enable of PFC burst mode; duty cycle of LLC burst mode	-	50	-	%
$N_{\text{cy(en)burst}}$	burst mode enable number of cycles	enable of PFC burst mode; cycles of LLC burst mode	-	8	-	
$\bar{d}_{\text{dis(burst)}}$	burst mode disable duty cycle	disable of PFC burst mode; duty cycle of LLC burst mode	-	75	-	%
$V_{\text{pu(SNSBOOST)}}$	pull-up voltage on pin SNSBOOST	to enter PFC burst mode off-state	-	2.95	-	V
$I_{\text{off(burst)}}$	burst mode off-state current	during PFC burst mode off-state	-7.1	-6.4	-5.7	μA
$\Delta V_{\text{off(burst)}}$	burst mode off-state voltage difference	during PFC burst mode off-state; between peak voltage and end of off-state	-	-75	-	mV
$V_{\text{on(burst)max}}$	maximum burst mode on-state voltage	during PFC burst mode on-state	2.29	2.37	2.45	V
$t_{\text{to(det)on(burst)}}$	burst mode on-state detection timeout time	during PFC burst mode on-state	3.7	4.0	4.3	ms
PFC protection controller						
$R_{\text{pd(SNSBOOST)}}$	pull-down resistance on pin SNSBOOST	at protection activation	-	550	-	Ω
$I_{\text{pd(SNSBOOST)}}$	pull-down current on pin SNSBOOST	during active protection	94	110	127	μA
$I_{\text{prot(SNSBOOST)}}$	protection current on pin SNSBOOST		-	60	-	nA
SNSOUT pin						
$V_{\text{ovp(SNSOUT)}}$	overvoltage protection voltage on pin SNSOUT		3.36	3.50	3.64	V
$I_{\text{prot(SNSOUT)}}$	protection current on pin SNSOUT	for open pin	-	-60	-	nA
SNSFB pin						
$V_{\text{bias(SNSFB)}}$	bias voltage on pin SNSFB	$I_{\text{SNSFB}} = -85 \mu\text{A}$	2.2	2.5	2.8	V

Symbol	Parameter	Conditions	Min	Typ	Max	Unit
Optobias regulator						
$I_{reg(SNSFB)}$	regulation current on pin SNSFB	$I_{start(burst)} = 106 \mu A$; tracks with $I_{start(burst)}$	-	-85	-	μA
$I_{reg(max)SNSFB}$	maximum regulation current on pin SNSFB	$I_{start(burst)} = 106 \mu A$; tracks with $I_{start(burst)}$	-	-310	-	μA
$I_{reg(min)SNSFB}$	minimum regulation current on pin SNSFB	$I_{start(burst)} = 106 \mu A$; tracks with $I_{start(burst)}$	-	-63	-	μA
Burst mode regulator						
$I_{start(burst)}$	burst mode start current	LLC burst mode	-123	-106	-89	μA
$I_{stop(burst)}$	burst mode stop current	LLC burst mode	-	-200	-	μA
GATELS and GATEHS pins						
$I_{source(GATEHS)}$	source current on pin GATEHS	$V_{GATEHS} - V_{HB} = 4 V$	-	-340	-	mA
$I_{source(GATELS)}$	source current on pin GATELS	$V_{GATELS} - V_{GND} = 4 V$	-	-340	-	mA
$I_{sink(GATEHS)}$	sink current on pin GATEHS	$V_{GATEHS} - V_{HB} = 2 V$	-	580	-	mA
		$V_{GATEHS} - V_{HB} = 11 V$	-	2	-	A
$I_{sink(GATELS)}$	sink current on pin GATELS	$V_{GATELS} - V_{GND} = 2 V$	-	580	-	mA
		$V_{GATELS} - V_{GND} = 11 V$	-	2	-	A
$V_{rst(SUPHS)}$	reset voltage on pin SUPHS		6.4	7	7.6	V
$V_{rst(hys)SUPHS}$	hysteresis of reset voltage on pin SUPHS	$> V_{rst(SUPHS)}$	-	0.6	-	V
$t_{on(min)}$	minimum on-time		-	0.83	-	μs
$t_{on(max)}$	maximum on-time		14.8	17.4	20.0	μs
t_{sweep}	sweep time	frequency; at start-up	1	12	14	ms
Low-power mode regulator						
$f_{ip(min)}$	minimum low-power mode frequency		20	23	26	kHz
Burst mode regulator						
$f_{burst(max)}$	maximum burst mode frequency	$R_{SNSOUT1} = 22 k\Omega$	170	200	230	Hz
		$R_{SNSOUT1} = 15 k\Omega$	340	400	460	Hz
		$R_{SNSOUT1} = 10 k\Omega$	680	800	920	Hz
		$R_{SNSOUT1} = 6.8 k\Omega$	1360	1600	1840	Hz
Power good characteristics (pin SNSSET)						
$V_{OH(SNSSET)}$	HIGH-level output voltage on pin SNSSET	$I_{SNSSET} = -100 \mu A$; power good = LOW	-	4	-	V
$I_{OH(SNSSET)}$	HIGH-level output current on pin SNSSET	$V_{SNSSET} = 3 V$; power good = LOW	-11	-8	-5	mA

Symbol	Parameter	Conditions	Min	Typ	Max	Unit
$I_{OL(SNSSET)}$	LOW-level output current on pin SNSSET	$V_{SNSSET} = 0.5 \text{ V}$; power good = HIGH	8	11	14	mA
$t_{d(H)SNSSET}$	HIGH-level delay time on pin SNSSET	See Table 6 for related $R_{SNSSET1}$	35	45	55	ms
		See Table 6 for related $R_{SNSSET1}$	150	190	230	ms
Settings sensor (SNSOUT, SNSSET, and GATELS pins)						
$I_{O(SNSOUT)}$	output current on pin SNSOUT	during $R_{SNSOUT1}$ measurement	-	-171	-	μA
$I_{O(SNSSET)}$	output current on pin SNSSET	during R_{SNSSET} measurement	-	-26.8	-	μA
$\Delta V_{O(GATELS-SUPREG)}$	output voltage difference between pin GATELS and pin SUPREG	during R_{GATELS} measurement	-	1.25	-	V
HB pin						
$(dV/dt)_{t_{no}(\min)}$	minimum non-overlap time rate of change of voltage		-	-	120	$\text{V}/\mu\text{s}$
$t_{no}(\min)$	minimum non-overlap time		-	200	-	ns
$t_{no}(\max)$	maximum non-overlap time		-	1.1	-	μs
Overtemperature protection						
T_{otp}	overtemperature protection trip		130	140	150	$^{\circ}\text{C}$

12 Application information

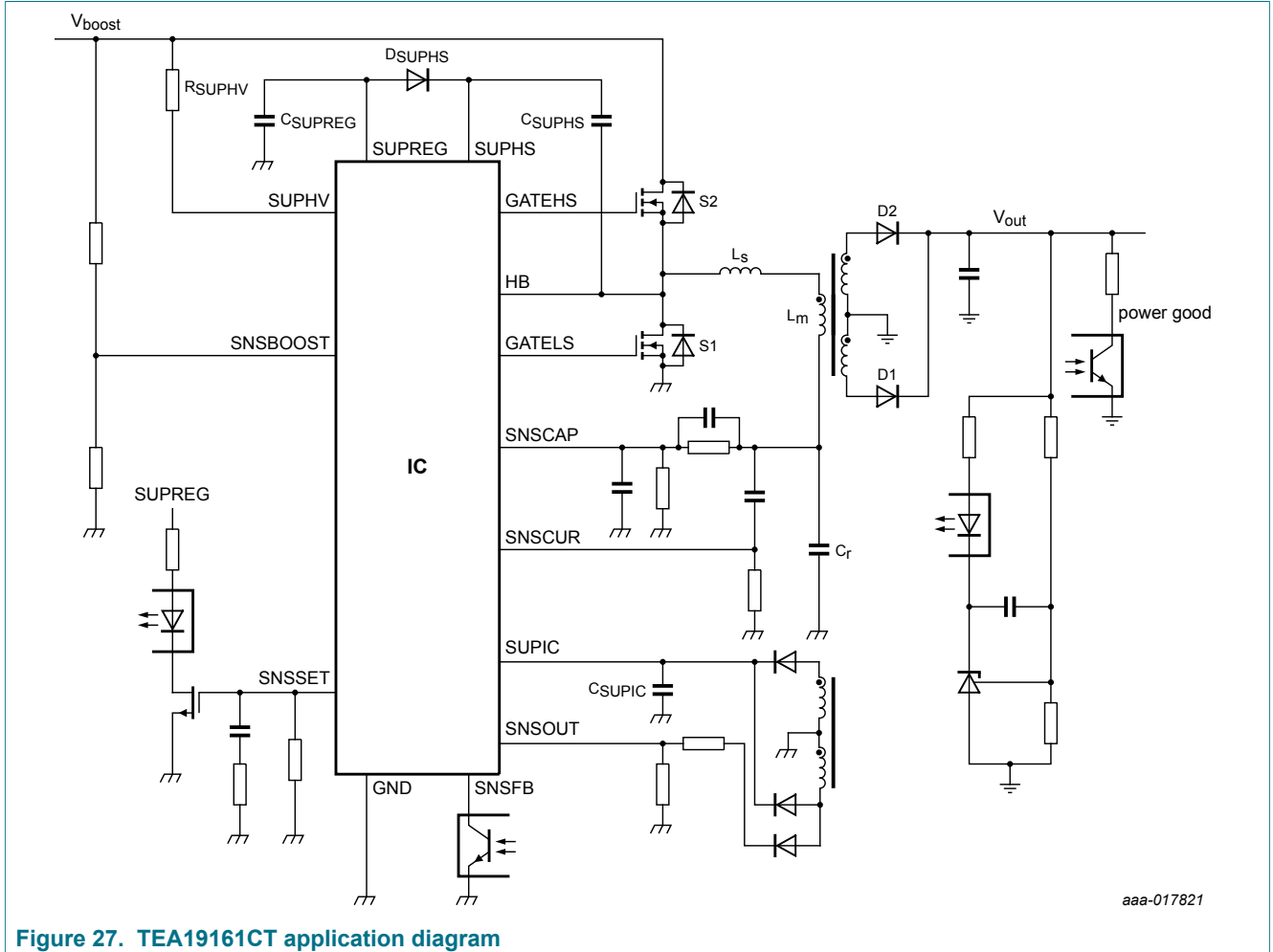
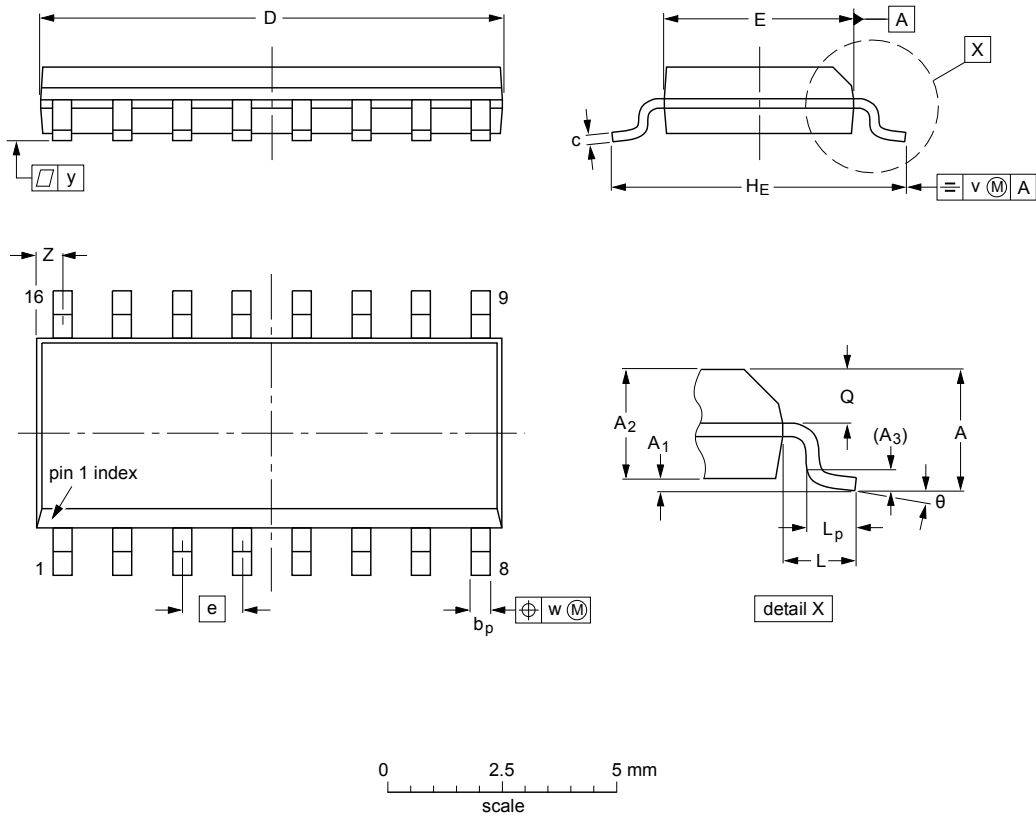

Figure 27. TEA19161CT application diagram

13 Package outline

SO16: plastic small outline package; 16 leads; body width 3.9 mm

SOT109-1



DIMENSIONS (inch dimensions are derived from the original mm dimensions)

UNIT	A max.	A ₁	A ₂	A ₃	b _p	c	D ⁽¹⁾	E ⁽¹⁾	e	H _E	L	L _p	Q	v	w	y	Z ⁽¹⁾	θ
mm	1.75	0.25 0.10	1.45 1.25	0.25	0.49 0.36	0.25 0.19	10.0 9.8	4.0 3.8	1.27	6.2 5.8	1.05	1.0 0.4	0.7 0.6	0.25	0.25	0.1	0.7 0.3	8° 0°
inches	0.069	0.010 0.004	0.057 0.049	0.01	0.019 0.014	0.0100 0.0075	0.39 0.38	0.16 0.15	0.05	0.244 0.228	0.041	0.039 0.016	0.028 0.020	0.01	0.01	0.004	0.028 0.012	

Note

1. Plastic or metal protrusions of 0.15 mm (0.006 inch) maximum per side are not included.

OUTLINE VERSION	REFERENCES			EUROPEAN PROJECTION	ISSUE DATE
	IEC	JEDEC	JEITA		
SOT109-1	076E07	MS-012			99-12-27 03-02-19

Figure 28. Package outline SOT109-1 (SO16)

14 Revision history

Table 11. Revision history

Document ID	Release date	Data sheet status	Change notice	Supersedes
TEA19161CT v.2	20200226	Product data sheet	-	TEA19161CT v.1
Modifications:	<ul style="list-style-type: none">• Section 4 "Ordering information" has been updated.• Section 13 "Package outline" has been updated.			
TEA19161CT v.1	20160310	Product data sheet	-	-

15 Legal information

15.1 Data sheet status

Document status ^{[1][2]}	Product status ^[3]	Definition
Objective [short] data sheet	Development	This document contains data from the objective specification for product development.
Preliminary [short] data sheet	Qualification	This document contains data from the preliminary specification.
Product [short] data sheet	Production	This document contains the product specification.

[1] Please consult the most recently issued document before initiating or completing a design.

[2] The term 'short data sheet' is explained in section "Definitions".

[3] The product status of device(s) described in this document may have changed since this document was published and may differ in case of multiple devices. The latest product status information is available on the Internet at URL <http://www.nxp.com>.

15.2 Definitions

Draft — The document is a draft version only. The content is still under internal review and subject to formal approval, which may result in modifications or additions. NXP Semiconductors does not give any representations or warranties as to the accuracy or completeness of information included herein and shall have no liability for the consequences of use of such information.

Short data sheet — A short data sheet is an extract from a full data sheet with the same product type number(s) and title. A short data sheet is intended for quick reference only and should not be relied upon to contain detailed and full information. For detailed and full information see the relevant full data sheet, which is available on request via the local NXP Semiconductors sales office. In case of any inconsistency or conflict with the short data sheet, the full data sheet shall prevail.

Product specification — The information and data provided in a Product data sheet shall define the specification of the product as agreed between NXP Semiconductors and its customer, unless NXP Semiconductors and customer have explicitly agreed otherwise in writing. In no event however, shall an agreement be valid in which the NXP Semiconductors product is deemed to offer functions and qualities beyond those described in the Product data sheet.

15.3 Disclaimers

Limited warranty and liability — Information in this document is believed to be accurate and reliable. However, NXP Semiconductors does not give any representations or warranties, expressed or implied, as to the accuracy or completeness of such information and shall have no liability for the consequences of use of such information. NXP Semiconductors takes no responsibility for the content in this document if provided by an information source outside of NXP Semiconductors. In no event shall NXP Semiconductors be liable for any indirect, incidental, punitive, special or consequential damages (including - without limitation - lost profits, lost savings, business interruption, costs related to the removal or replacement of any products or rework charges) whether or not such damages are based on tort (including negligence), warranty, breach of contract or any other legal theory. Notwithstanding any damages that customer might incur for any reason whatsoever, NXP Semiconductors' aggregate and cumulative liability towards customer for the products described herein shall be limited in accordance with the Terms and conditions of commercial sale of NXP Semiconductors.

Right to make changes — NXP Semiconductors reserves the right to make changes to information published in this document, including without limitation specifications and product descriptions, at any time and without

notice. This document supersedes and replaces all information supplied prior to the publication hereof.

Suitability for use — NXP Semiconductors products are not designed, authorized or warranted to be suitable for use in life support, life-critical or safety-critical systems or equipment, nor in applications where failure or malfunction of an NXP Semiconductors product can reasonably be expected to result in personal injury, death or severe property or environmental damage. NXP Semiconductors and its suppliers accept no liability for inclusion and/or use of NXP Semiconductors products in such equipment or applications and therefore such inclusion and/or use is at the customer's own risk.

Applications — Applications that are described herein for any of these products are for illustrative purposes only. NXP Semiconductors makes no representation or warranty that such applications will be suitable for the specified use without further testing or modification. Customers are responsible for the design and operation of their applications and products using NXP Semiconductors products, and NXP Semiconductors accepts no liability for any assistance with applications or customer product design. It is customer's sole responsibility to determine whether the NXP Semiconductors product is suitable and fit for the customer's applications and products planned, as well as for the planned application and use of customer's third party customer(s). Customers should provide appropriate design and operating safeguards to minimize the risks associated with their applications and products. NXP Semiconductors does not accept any liability related to any default, damage, costs or problem which is based on any weakness or default in the customer's applications or products, or the application or use by customer's third party customer(s). Customer is responsible for doing all necessary testing for the customer's applications and products using NXP Semiconductors products in order to avoid a default of the applications and the products or of the application or use by customer's third party customer(s). NXP does not accept any liability in this respect.

Limiting values — Stress above one or more limiting values (as defined in the Absolute Maximum Ratings System of IEC 60134) will cause permanent damage to the device. Limiting values are stress ratings only and (proper) operation of the device at these or any other conditions above those given in the Recommended operating conditions section (if present) or the Characteristics sections of this document is not warranted. Constant or repeated exposure to limiting values will permanently and irreversibly affect the quality and reliability of the device.

Terms and conditions of commercial sale — NXP Semiconductors products are sold subject to the general terms and conditions of commercial sale, as published at <http://www.nxp.com/profile/terms>, unless otherwise agreed in a valid written individual agreement. In case an individual agreement is concluded only the terms and conditions of the respective agreement shall apply. NXP Semiconductors hereby expressly objects to applying the customer's general terms and conditions with regard to the purchase of NXP Semiconductors products by customer.

Digital controller for high-efficiency resonant power supply

No offer to sell or license — Nothing in this document may be interpreted or construed as an offer to sell products that is open for acceptance or the grant, conveyance or implication of any license under any copyrights, patents or other industrial or intellectual property rights.

Export control — This document as well as the item(s) described herein may be subject to export control regulations. Export might require a prior authorization from competent authorities.

Non-automotive qualified products — Unless this data sheet expressly states that this specific NXP Semiconductors product is automotive qualified, the product is not suitable for automotive use. It is neither qualified nor tested in accordance with automotive testing or application requirements. NXP Semiconductors accepts no liability for inclusion and/or use of non-automotive qualified products in automotive equipment or applications. In the event that customer uses the product for design-in and use in automotive applications to automotive specifications and standards, customer (a) shall use the product without NXP Semiconductors' warranty of the product for such automotive applications, use and specifications, and (b) whenever customer uses the product for automotive applications beyond NXP Semiconductors' specifications such use shall be solely at customer's own risk, and (c) customer fully indemnifies NXP Semiconductors for any liability, damages or failed product claims resulting from customer design and use

of the product for automotive applications beyond NXP Semiconductors' standard warranty and NXP Semiconductors' product specifications.

Translations — A non-English (translated) version of a document is for reference only. The English version shall prevail in case of any discrepancy between the translated and English versions.

Security — While NXP Semiconductors has implemented advanced security features, all products may be subject to unidentified vulnerabilities. Customers are responsible for the design and operation of their applications and products to reduce the effect of these vulnerabilities on customer's applications and products, and NXP Semiconductors accepts no liability for any vulnerability that is discovered. Customers should implement appropriate design and operating safeguards to minimize the risks associated with their applications and products.

15.4 Trademarks

Notice: All referenced brands, product names, service names and trademarks are the property of their respective owners.

GreenChip — is a trademark of NXP B.V.

Contents

1	General description	1
2	Features and benefits	2
2.1	Distinctive features	2
2.2	Green features	2
2.3	Protection features	2
3	Applications	2
4	Ordering information	3
5	Marking	3
6	Block diagram	3
7	Pinning information	4
7.1	Pinning	4
7.2	Pin description	4
8	Functional description	5
8.1	Supply voltages	5
8.1.1	Start-up and supply voltage	5
8.1.2	Regulated supply (SUPREG pin)	7
8.1.3	High-side driver floating supply (SUPHS pin)	7
8.2	System start-up	8
8.3	LLC system regulation	9
8.3.1	Output power regulation loop	11
8.3.2	Output voltage start-up	12
8.4	Modes of operation	13
8.4.1	High-power mode	14
8.4.2	Low-power mode	15
8.4.3	Burst mode	18
8.5	Optobias regulation	19
8.6	Protections	20
8.6.1	Undervoltage protection SUPIC/SUPREG	20
8.6.2	Undervoltage protection SUPHS	20
8.6.3	Undervoltage protection boost	21
8.6.4	Overvoltage protection	21
8.6.5	Capacitive mode regulation (CMR)	21
8.6.6	Overcurrent protection	22
8.6.7	Overtemperature protection	22
8.6.8	Overpower protection	23
8.7	External settings	23
8.7.1	Burst period	23
8.7.2	General settings	24
8.7.3	Low-power mode/burst mode transition levels	25
8.8	Power good function	26
8.9	PFC/LLC communication protocol	27
8.9.1	Start-up	27
8.9.2	Protection	28
8.9.3	Fast latch reset	30
8.9.4	PFC burst mode	31
9	Limiting values	33
10	Thermal characteristics	34
11	Characteristics	34
12	Application information	39
13	Package outline	40
14	Revision history	41
15	Legal information	42

Please be aware that important notices concerning this document and the product(s) described herein, have been included in section 'Legal information'.

© NXP B.V. 2020.

All rights reserved.

For more information, please visit: <http://www.nxp.com>

For sales office addresses, please send an email to: salesaddresses@nxp.com

Date of release: 26 February 2020
Document identifier: TEA19161CT