

DATA SHEET

TEA1098A

Speech and handsfree IC

Preliminary specification
File under Integrated Circuits, IC03

2000 Mar 21

Speech and handsfree IC

TEA1098A

FEATURES

Line interface

- Low DC line voltage
- Voltage regulator with adjustable DC voltage
- Symmetrical high impedance inputs (70 k Ω) for dynamic, magnetic or electret microphones
- DTMF input with confidence tone on earphone and/or loudspeaker
- Earphone amplifier for dynamic, magnetic or piezo-electric earpieces (with externally adjustable gain)
- Digital volume control on earphone amplifier (4 steps)
- Automatic Gain Control (AGC) for true line loss compensation
- Microphone mute
- Key tone mode.

Supplies

- Provides a strong 3.35 V regulated supply for microcontroller or dialler
- Provides filtered power supply, optimized according to line current
- Filtered 2.0 V power supply output for electret microphone
- $\overline{\text{PD}}$ logic input for power-down.

Handsfree

- Asymmetrical high input impedance for electret microphone
- Loudspeaker amplifier with single-ended rail-to-rail output and externally adjustable gain
- Dynamic limiter on loudspeaker amplifier to prevent distortion
- Digital volume control on loudspeaker amplifier (8 steps)

- Duplex controller consisting of:

- signal and noise envelope monitors for both channels (with adjustable sensitivities and timing)
- decision logic (with adjustable switch-over and Idle mode timing)
- voice switch control (with adjustable switching range and constant sum of gain during switching).

APPLICATIONS

- Line powered telephone sets.

GENERAL DESCRIPTION

The TEA1098A is an analog bipolar circuit dedicated for telephony applications. It includes a line interface, handset (HS) microphone and earpiece amplifiers, handsfree (HF) microphone and loudspeaker amplifiers and a duplex controller with signal and noise monitors on both channels. Digital volume control is available both on earphone and loudspeaker amplifiers.

This IC provides a 3.35 V strong supply for a microcontroller and a 2.0 V filtered voltage supply for an electret microphone.

ORDERING INFORMATION

TYPE NUMBER	PACKAGE		
	NAME	DESCRIPTION	VERSION
TEA1098ATV	VSO40	plastic very small outline package; 40 leads	SOT158-1
TEA1098AH	QFP44	plastic quad flat package; 44 leads (lead length 1.3 mm); body 10 × 10 × 1.75 mm	SOT307-2

Speech and handsfree IC

TEA1098A

QUICK REFERENCE DATA

$I_{line} = 15 \text{ mA}$; $R_{SLPE} = 20 \ \Omega$; $Z_{line} = 600 \ \Omega$; $f = 1 \text{ kHz}$; $T_{amb} = 25 \text{ }^\circ\text{C}$; AGC pin connected to LN; $\overline{PD} = \text{HIGH}$; HFC = LOW; MUTE = HIGH; BPC = HIGH; measured according to test circuits; unless otherwise specified.

SYMBOL	PARAMETER	CONDITIONS	MIN.	TYP.	MAX.	UNIT
I_{line}	line current operating range	normal operation	11	–	130	mA
		with reduced performance	1	–	11	mA
V_{SLPE}	stabilized voltage between SLPE and GND	$I_{line} = 15 \text{ mA}$	3.4	3.7	4.0	V
		$I_{line} = 70 \text{ mA}$	5.7	6.1	6.5	V
V_{BB}	regulated supply voltage for internal circuitry	$I_{line} = 15 \text{ mA}$	2.75	3.0	3.25	V
		$I_{line} = 70 \text{ mA}$	4.9	5.3	5.7	V
V_{DD}	regulated supply voltage on pin V_{DD}	$V_{BB} > 3.35 \text{ V} + 0.25 \text{ V (typ.)}$	3.1	3.35	3.6	V
		otherwise	–	$V_{BB} - 0.25$	–	V
I_{BB}	current available on pin V_{BB} in speech mode in handsfree mode		–	11	–	mA
			–	9	–	mA
$I_{BB(PD)}$	current consumption on V_{BB} during power-down phase	$\overline{PD} = \text{LOW}$	–	460	–	μA
$G_{V(\text{MIC-LN})}$	voltage gain from pin MIC+/MIC– to LN	$V_{\text{MIC}} = 5 \text{ mV (RMS)}$	43.3	44.3	45.3	dB
$G_{V(\text{IR-RECO})}$	voltage gain from pin IR (referenced to LN) to RECO	$V_{\text{IR}} = 15 \text{ mV (RMS)}$; HFC = HIGH	28.7	29.7	30.7	dB
$\Delta G_{V(\text{RECO-EARO})}$	gain voltage range between pins RECO and EARO		–3	–	+15	dB
$G_{V(\text{TXI-TXO})}$	voltage gain from pin TXI to TXO	$V_{\text{TXI}} = 3 \text{ mV (RMS)}$; $R_{\text{GATX}} = 30.1 \text{ k}\Omega$	12.7	15.2	17.7	dB
$G_{V(\text{HFTX-LN})}$	voltage gain from pin HFTX to LN	$V_{\text{HFTX}} = 15 \text{ mV (RMS)}$	33.5	34.7	35.9	dB
$G_{V(\text{HFRX-LSAO})}$	voltage gain from pin HFRX to LSAO	$V_{\text{HFRX}} = 30 \text{ mV (RMS)}$; $R_{\text{GALS}} = 255 \text{ k}\Omega$; $I_{line} = 70 \text{ mA}$	25.5	28	30.5	dB
SWR	switching range		–	40	–	dB
ΔSWR	switching range adjustment	with R_{SWR} referenced to $365 \text{ k}\Omega$	–40	–	+12	dB
$\Delta G_{V(\text{trx})}$	gain control range for transmit and receive amplifiers affected by the AGC; with respect to $I_{line} = 15 \text{ mA}$	$I_{line} = 70 \text{ mA}$	5.45	6.45	7.45	dB

Speech and handsfree IC

TEA1098A

BLOCK DIAGRAM

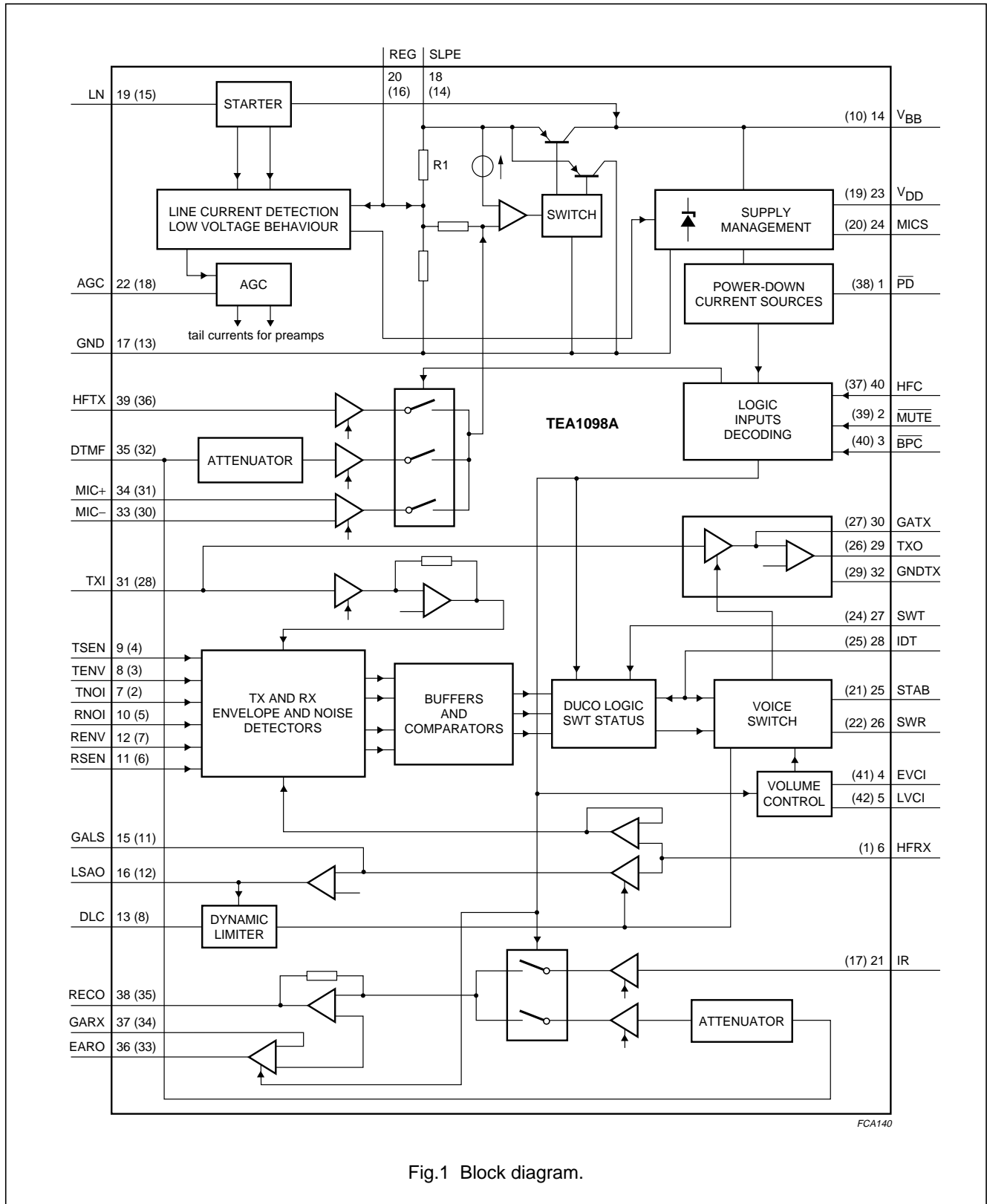

Fig.1 Block diagram.

Speech and handsfree IC

TEA1098A

PINNING

SYMBOL	PIN		DESCRIPTION
	TEA1098ATV	TEA1098AH	
$\overline{\text{PD}}$	1	38	power-down input (active LOW)
$\overline{\text{MUTE}}$	2	39	logic input (active LOW)
$\overline{\text{BPC}}$	3	40	logic input (active LOW)
EVCI	4	41	logic input for digital volume control (earpiece and loudspeaker LSB)
LVCI	5	42	logic input for digital volume control (loudspeaker MSB)
n.c.	–	43	not connected
n.c.	–	44	not connected
HFRX	6	1	receive input for loudspeaker amplifier
TNOI	7	2	transmit noise envelope timing adjustment
TENV	8	3	transmit signal envelope timing adjustment
TSEN	9	4	transmit signal envelope sensitivity adjustment
RNOI	10	5	receive noise envelope timing adjustment
RSEN	11	6	receive signal envelope sensitivity adjustment
RENV	12	7	receive signal envelope timing adjustment
DLC	13	8	dynamic limiter capacitor for the loudspeaker amplifier
n.c.	–	9	not connected
V_{BB}	14	10	stabilized supply for internal circuitry
GALS	15	11	loudspeaker amplifier gain adjustment
LSAO	16	12	loudspeaker amplifier output
GND	17	13	ground reference
SLPE	18	14	line current sense
LN	19	15	positive line terminal
REG	20	16	line voltage regulator decoupling
IR	21	17	receive amplifier input
AGC	22	18	automatic gain control/line loss compensation
V_{DD}	23	19	3.35 V regulated voltage supply for microcontrollers
MICS	24	20	microphone supply
STAB	25	21	reference current adjustment
SWR	26	22	switching range adjustment
n.c.	–	23	not connected
SWT	27	24	switch-over timing adjustment
IDT	28	25	Idle mode timing adjustment
TXO	29	26	handsfree microphone amplifier output
GATX	30	27	handsfree microphone amplifier gain adjustment
TXI	31	28	handsfree microphone amplifier input
GNDTX	32	29	ground reference for microphone amplifiers
MIC–	33	30	negative handset microphone amplifier input
MIC+	34	31	positive handset microphone amplifier input

Speech and handsfree IC

TEA1098A

SYMBOL	PIN		DESCRIPTION
	TEA1098ATV	TEA1098AH	
DTMF	35	32	dual tone multi-frequency input
EARO	36	33	earpiece amplifier output
GARX	37	34	earpiece amplifier gain adjustment
RECO	38	35	receive amplifier output
HFTX	39	36	transmit input for line amplifier
HFC	40	37	logic input

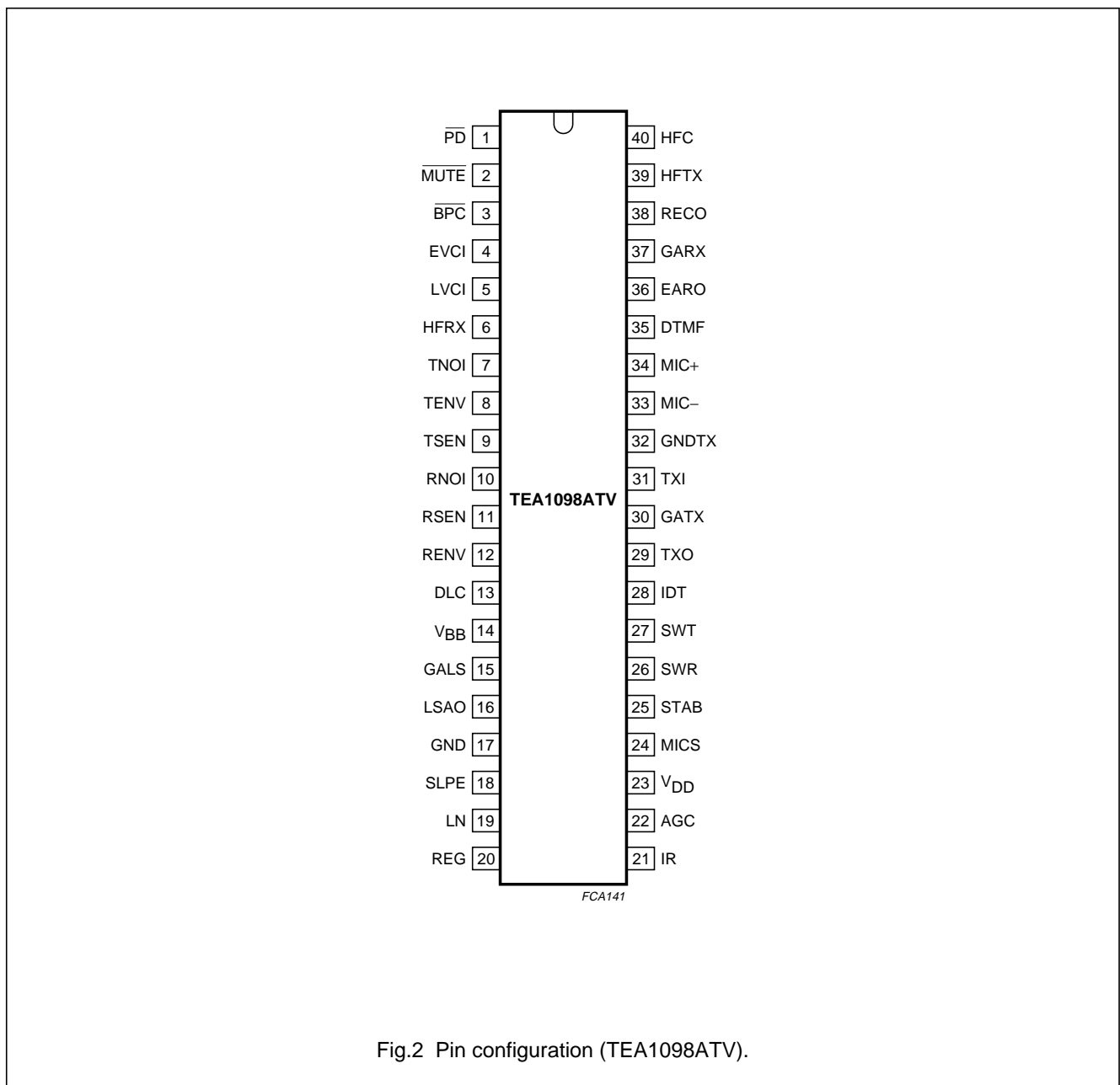
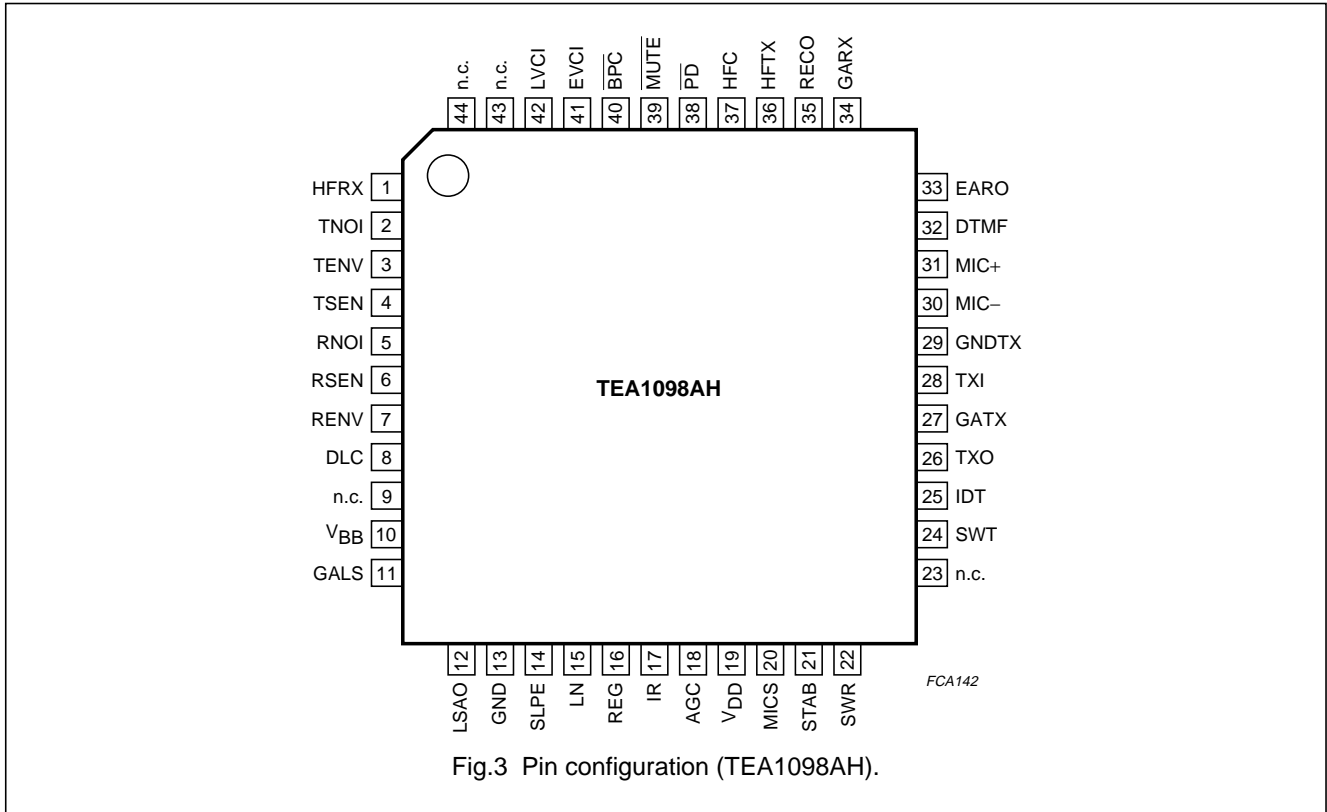

Fig.2 Pin configuration (TEA1098ATV).

Speech and handsfree IC

TEA1098A



FUNCTIONAL DESCRIPTION

All data given in this chapter are typical values, except when otherwise specified.

Supplies

LINE INTERFACE AND INTERNAL SUPPLY (PINS LN, SLPE, REG AND V_{BB})

The supply for the TEA1098A and its peripherals is obtained from the line. The IC generates a stabilized reference voltage (V_{ref}) between pins SLPE and GND.

This reference voltage is equal to 3.7 V for line currents lower than 18 mA. It then increases linearly with the line current and reaches the value of 6.1 V for line currents higher than 45 mA. For line currents below 9 mA, the internal reference voltage generating V_{ref} is automatically adjusted to a lower value. This is the so-called low voltage area and the TEA1098A has limited performances in this area (see Section "Low voltage behaviour"). This reference voltage is temperature compensated.

The voltage between pins SLPE and REG is used by the internal regulator to generate the stabilized reference voltage and is decoupled by means of a capacitor between pins LN and REG.

This capacitor converted into an equivalent inductance realizes the set impedance conversion from its DC value (R_{SLPE}) to its AC value (done by an external impedance).

The IC regulates the line voltage at pin LN and can be calculated as follows:

$$V_{LN} = V_{ref} + R_{SLPE} \times I_{SLPE}$$

$$I_{SLPE} = I_{line} - I^x$$

where:

I_{line} = line current

I^x = current consumed on pin LN (approximately a few μA)

I_{SLPE} = current flowing through the R_{SLPE} resistor

The preferred value for R_{SLPE} is 20 Ω . Changing this value will affect more than the DC characteristics; it also influences the transmit gains to the line, the gain control characteristic, the sidetone level and the maximum output swing on the line.

Speech and handsfree IC

TEA1098A

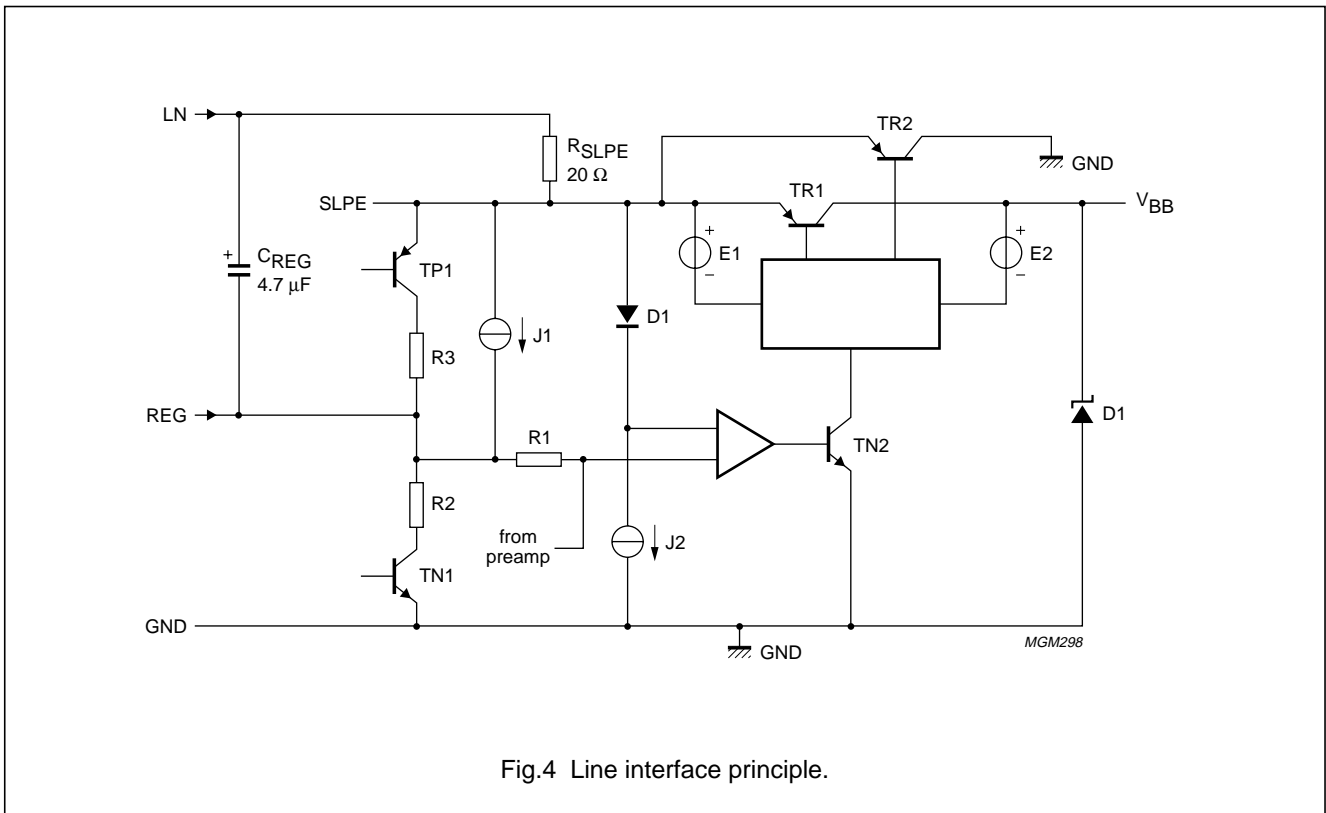

As can be seen from Fig.4, the internal circuitry is supplied by pin V_{BB} , which is a strong supply point combined with the line interface. The line current is flowing through the R_{SLPE} resistor and is sunk by the V_{BB} voltage stabilizer, thus becoming available for a loudspeaker amplifier or any peripheral IC. Its voltage is equal to 3.0 V for line currents lower than 18 mA. It then increases linearly with the line current and reaches the value of 5.3 V for line currents greater than 45 mA. It is temperature compensated.

The aim of the current switch TR1 and TR2 is to reduce distortion of large AC line signals. Current I_{SLPE} is supplied to V_{BB} via TR1 when the voltage on SLPE is greater than $V_{BB} + 0.25$ V. When the voltage on SLPE is lower than this value, the current I_{SLPE} is shunted to GND via TR2.

The reference voltage V_{ref} can be increased by connecting an external resistor between pins REG and SLPE. For large line currents, this increase can slightly affect some dynamic performances such as maximum signal level on the line for 2% THD. The voltage on pin V_{BB} is not affected by this external resistor; see Fig.5 for the main DC voltages.

Speech and handsfree IC

TEA1098A

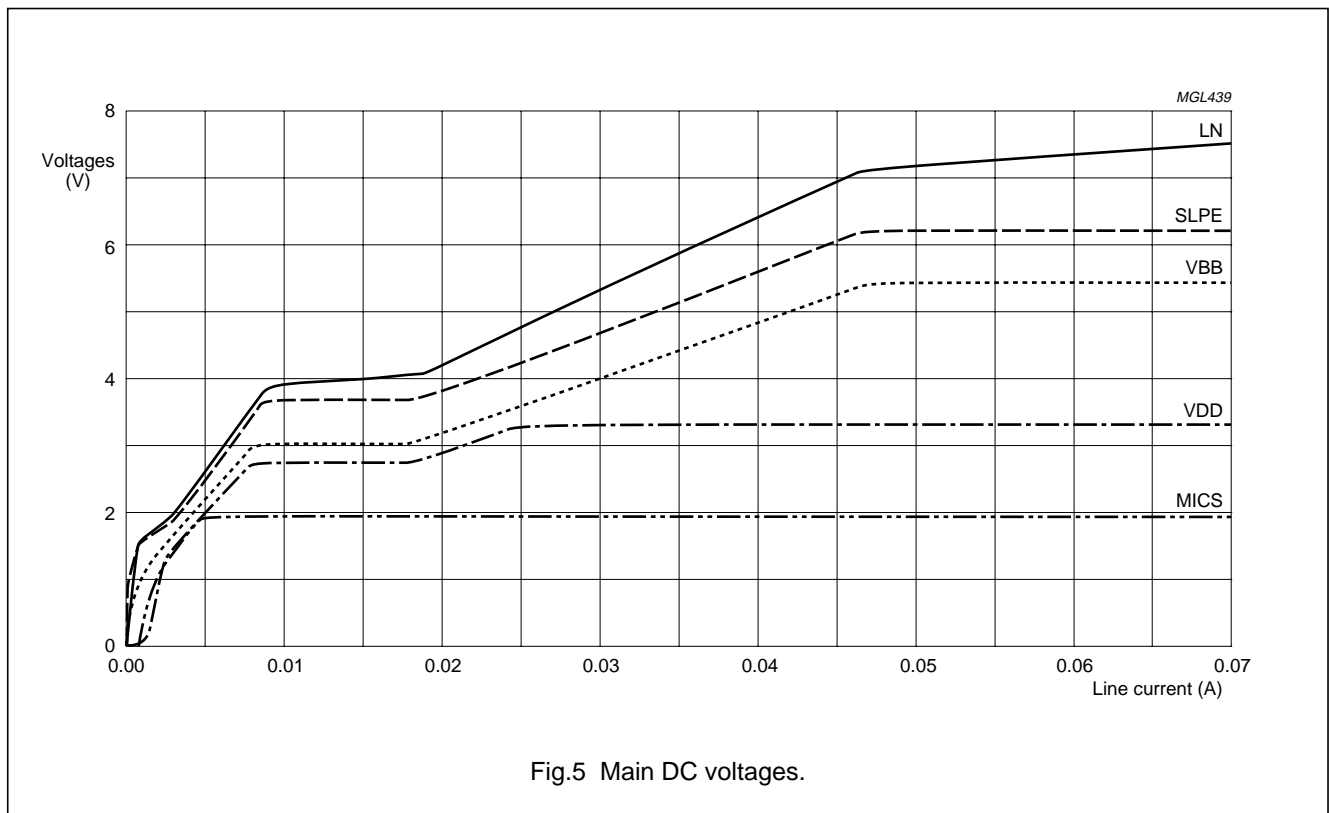
 V_{DD} SUPPLY FOR MICROCONTROLLER (PIN V_{DD})

The voltage on the V_{DD} supply point follows the voltage on V_{BB} with a difference typically equal to 250 mV and is internally limited to 3.35 V. This voltage is temperature compensated. This supply point can provide a current up to 3 mA typically. Its internal consumption stays low (a few 10 nA) as long as V_{DD} does not exceed 1.5 V.

V_{DD} can also be used as an input; in this case the voltage will be stabilised to 3.35 V up to 75 mA input current.

V_{BB} and V_{DD} can supply external circuits in the limit of currents provided from the line, taking into account the internal current consumption.

Speech and handsfree IC

TEA1098A

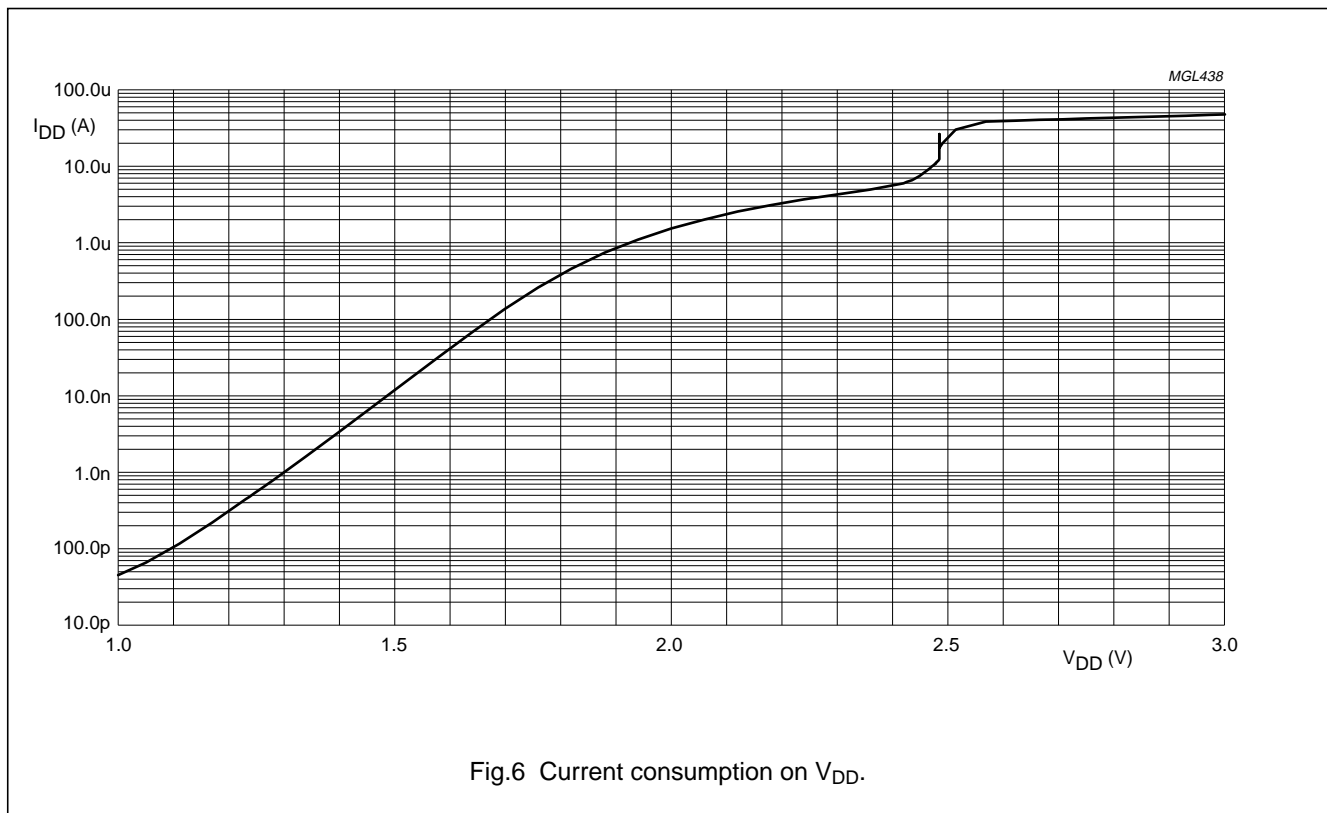

SUPPLY FOR MICROPHONE (PINS MICS AND GNCTX)

The MICS output can be used as a supply for an electret microphone. Its voltage is equal to 2.0 V; it can source a current up to 1 mA and has an output impedance equal to 200 Ω .

LOW VOLTAGE BEHAVIOUR

For line currents below 9 mA, the reference voltage is automatically adjusted to a lower value; the V_{BB} voltage follows the SLPE voltage with 250 mV difference. The excess current available for other purposes than DC biasing of the IC becomes small. In this low voltage area, the IC has limited performances.

When the V_{BB} voltage becomes lower than 2.7 V, the V_{BB} detector of the receive dynamic limiter on pin LSAO acts continuously, discharging the capacitor connected to pin DLC. In the DC condition, the loudspeaker is then automatically disabled below this voltage.

When V_{BB} goes below 2.5 V, the TEA1098A is forced into a low voltage mode whatever the levels on the logic inputs are. It is a speech mode with reduced performances only enabling the microphone channel (between the MIC inputs and LN) and the earpiece amplifier. These two channels are able to deliver signals for line currents as small as 3 mA. The HFC input is tied to GND sinking a current typically equal to 300 μ A.

POWER-DOWN MODE (PIN \overline{PD})

To reduce consumption during dialling or register recall (flash), the TEA1098A is provided with a power-down input (\overline{PD}). When the voltage on pin \overline{PD} is LOW, the current consumption from V_{BB} and V_{DD} is reduced to 460 μ A typically. Therefore a capacitor of 470 μ F on V_{BB} is sufficient to power the TEA1098A during pulse dialling or flash. The \overline{PD} input has a pull-up structure. In this mode, the capacitor C_{REG} is internally disconnected.

Speech and handsfree IC

TEA1098A

Transmit channels (pins MIC+, MIC-, DTMF, HFTX and LN)**HANDSET MICROPHONE AMPLIFIER (PINS MIC+, MIC- AND LN)**

The TEA1098A has symmetrical microphone inputs. The input impedance between pins MIC+ and MIC- is typically 70 k Ω . The voltage gain between pins MIC+/MIC- and LN is set to 44.3 dB. Without limitation from the output, the microphone input stage can accommodate signals up to 18 mV (RMS) at room temperature for 2% of Total Harmonic Distortion (THD). The microphone inputs are biased at one diode voltage.

Automatic gain control is provided for line loss compensation.

DTMF AMPLIFIER (PINS DTMF, LN AND RECO)

The TEA1098A has an asymmetrical DTMF input. The input impedance between pins DTMF and GND is typically 20 k Ω . The voltage gain between pins DTMF and LN is set to 25.35 dB. Without limitation from the output, the input stage can accommodate signals up to 180 mV (RMS) at room temperature for 2% of THD.

When the DTMF amplifier is enabled, dialling tones may be sent on the line. These tones can be heard in the earpiece or in the loudspeaker at a low level. This is called the confidence tone. The voltage attenuation between pins DTMF and RECO is typically -16.5 dB in handsfree mode (HFC HIGH), and -28.2 dB in handset mode (HFC LOW).

The DC biasing of this input is 0 V.

The automatic gain control has no effect on these channels.

HANDSFREE TRANSMIT AMPLIFIER (PINS HFTX AND LN)

The TEA1098A has an asymmetrical HFTX input, which is mainly intended for use in combination with the TXO output. The input impedance between pins HFTX and GND is typically 20 k Ω . The voltage gain between pins HFTX and LN is set to 34.7 dB. Without limitation from the output, the input stage can accommodate signals up to 95 mV (RMS) at room temperature for 2% of THD. The HFTX input is biased at two diodes voltage.

Automatic gain control is provided for line loss compensation.

Receive channels (pins IR, RECO, GARX, EARO and EVCI)**RX AMPLIFIER (PINS IR, RECO AND EVCI)**

The receive amplifier has one input IR which is referred to the line. The input impedance between pins IR and LN is typically 20 k Ω and the DC biasing between these pins is equal to one diode voltage.

When HFC = 0, the gain between pins IR (referred to LN) and RECO is typically 17.0 dB which compensates typically 15 dB lower than attenuation of the anti-sidetone network. The receive amplifier gain can be digitally increased with the 4-level logic input EVCI, providing 4 steps of 4.85 dB which apply in all handset receive modes. Without limitation from the output, the input stage can accommodate signals up to 50 mV (RMS) at room temperature for 2% of THD.

When HFC = 1, the gain is set automatically to 29.7 dB which compensate the anti-sidetone network attenuation minus 2.3 dB.

This receive amplifier has a rail-to-rail output RECO, which is designed for use with high ohmic (real) loads (larger than 5 k Ω). This output is biased at two diodes voltage.

Automatic gain control is provided for line loss compensation.

EARPIECE AMPLIFIER (PINS GARX AND EARO)

The earpiece amplifier is an operational amplifier having its output (EARO) and its inverting input (GARX) available. Its input signal comes, via a decoupling capacitor, from the receive output RECO. It is used in combination with two resistors to get the required gain or attenuation compared to the receive gain. The typical resistor ratio is 4, which gives a 12 dB gain. The gain range can be chosen between 0 dB and 20 dB.

Two external capacitors C_{GAR} (connected between pins GAR and EARO) and C_{GARS} (connected between pins GAR and GND) ensure stability. The C_{GAR} capacitor provides a first-order low-pass filter. The cut-off frequency corresponds to the time constant $C_{GAR} \times R_{E2}$. The relationship $C_{GARS} \geq 10 \times C_{GAR}$ must be fulfilled.

The earpiece amplifier has a rail-to-rail output EARO, biased at two diodes voltage. It is designed for use with low ohmic (real) loads (150 Ω) or capacitive loads (100 nF in series with 100 Ω).

Speech and handsfree IC

TEA1098A

AGC (pin AGC)

The TEA1098A performs automatic line loss compensation, which fits well with the true line attenuation. The automatic gain control varies the gain of some transmit and receive amplifiers in accordance with the DC line current. The control range is 6.45 dB for $G_{V(MIC-LN)}$ and $G_{V(IR-RECO)}$ and 6.8 dB for $G_{V(HFTX-LN)}$, which corresponds approximately to a line length of 5.5 km for a 0.5 mm twisted-pair copper cable.

To enable this gain control, pin AGC must be shorted to pin LN. The start current for compensation corresponds to a line current of typically 23 mA and the stop current to 57 mA. The start current can be increased by connecting an external resistor between pins AGC and LN. It can be increased up to 40 mA (using a resistor typically 80 kΩ). The start and stop current will be maintained in a ratio equal to 2.5. By leaving the AGC pin open-circuit, the gain control is disabled and no line loss compensation is performed.

Handsfree application

As can be seen from Fig.4, a loop is formed via the sidetone network in the line interface part and the acoustic coupling between loudspeaker and microphone of the handsfree part. When this loop gain is greater than 1, howling occurs. In a full duplex application this would be the case. The loop-gain has to be much lower than 1 and therefore has to be decreased to avoid howling.

This is achieved by the duplex controller. The duplex controller of the TEA1098A detects which channel has the 'largest' signal and then controls the gains of the microphone and loudspeaker amplifiers so that the sum of the gains remains constant.

As a result, in handsfree application, the circuit can be in three stable modes:

1. Transmit mode (TX mode).
The gain of the microphone amplifier is at its maximum and the gain of the loudspeaker amplifier is at its minimum.
2. Receive mode (RX mode).
The gain of the loudspeaker amplifier is at its maximum and the gain of the microphone amplifier is at its minimum.
3. Idle mode.
The gain of the amplifiers is halfway between their maximum and minimum value.

The difference between the maximum gain and minimum gain is called the switching range.

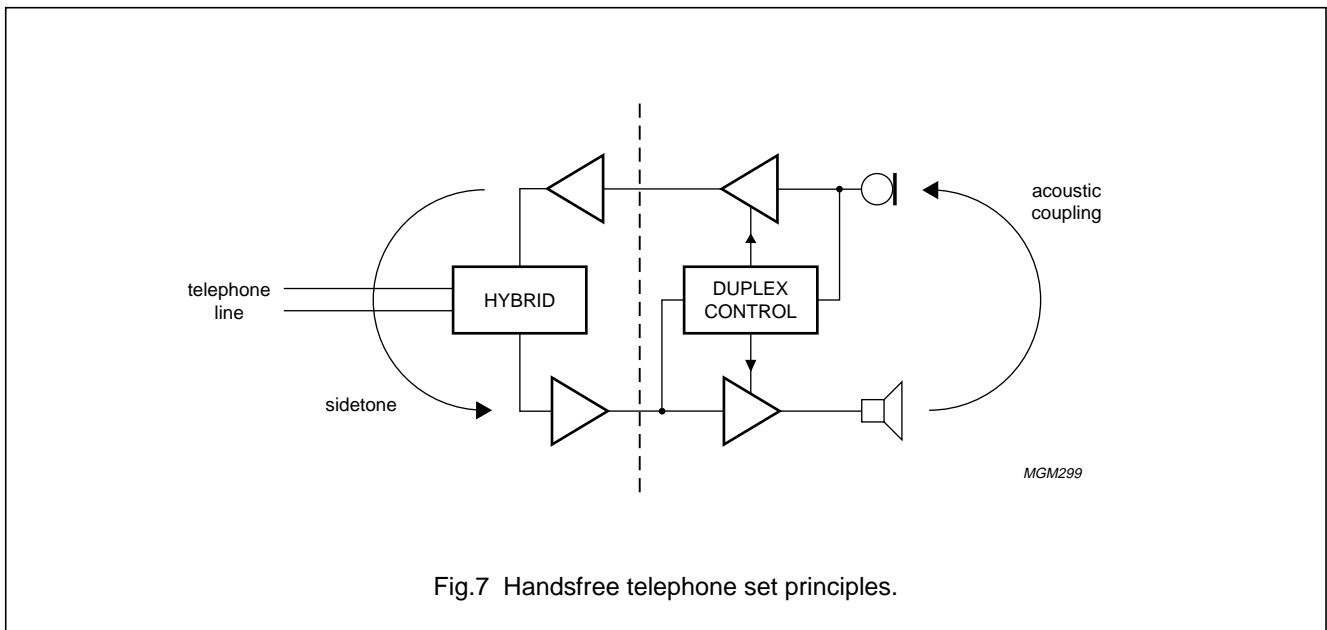

Fig.7 Handsfree telephone set principles.

Speech and handsfree IC

TEA1098A

HANDSFREE MICROPHONE CHANNEL (PINS TXI, GATX, TXO AND GNCTX; SEE Fig.8)

The TEA1098A has an asymmetrical handsfree microphone input (pin TXI) with an input resistance of 20 kΩ. The DC biasing of the input is 0 V. The gain of the input stage varies according to the mode of the TEA1098A. In the transmit mode, the gain is at its maximum; in the receive mode, it is at its minimum and in the Idle mode, it is halfway between maximum and minimum.

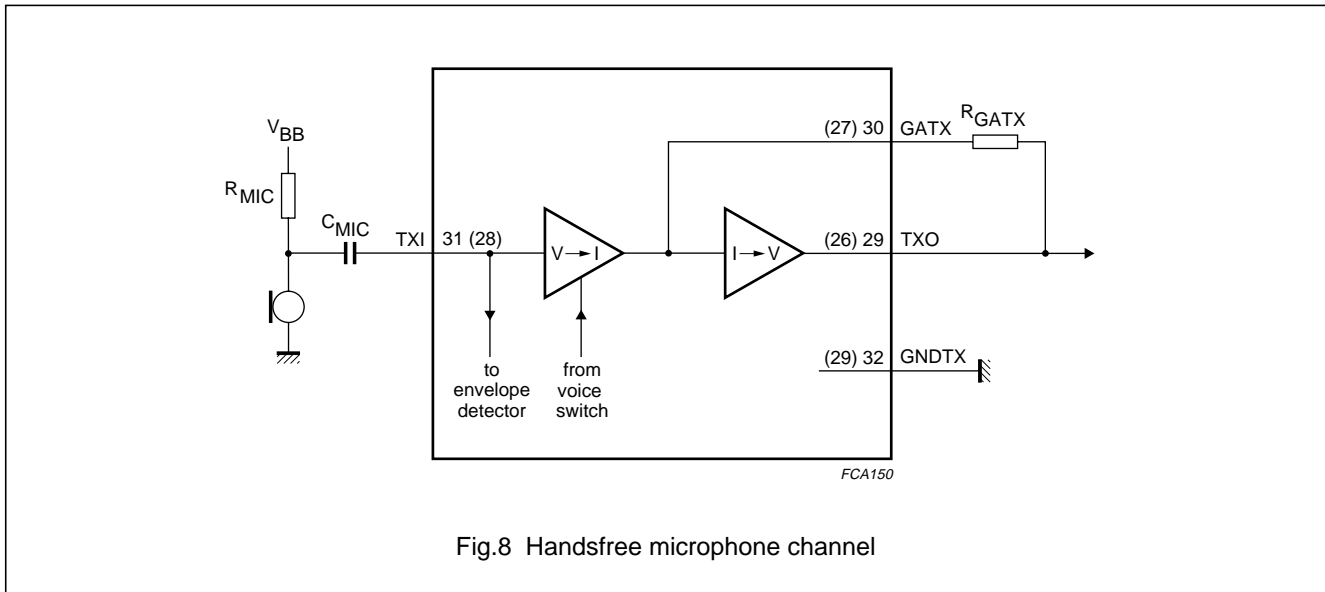

Switch-over from one mode to the other is smooth and click-free. The output TXO is biased at two diodes voltage and has a current capability equal to 20 μA (RMS). In the transmit mode, the overall gain of the microphone amplifier (from pins TXI to TXO) can be adjusted from 0 dB up to 31 dB to suit specific application requirements. The gain is proportional to the value of R_GATX and equals 15.2 dB with R_GATX = 30.1 kΩ. Without limitation from the output, the microphone input stage can accommodate signals up to 18 mV (RMS) at room temperature for 2% of THD.

LOUDSPEAKER CHANNEL

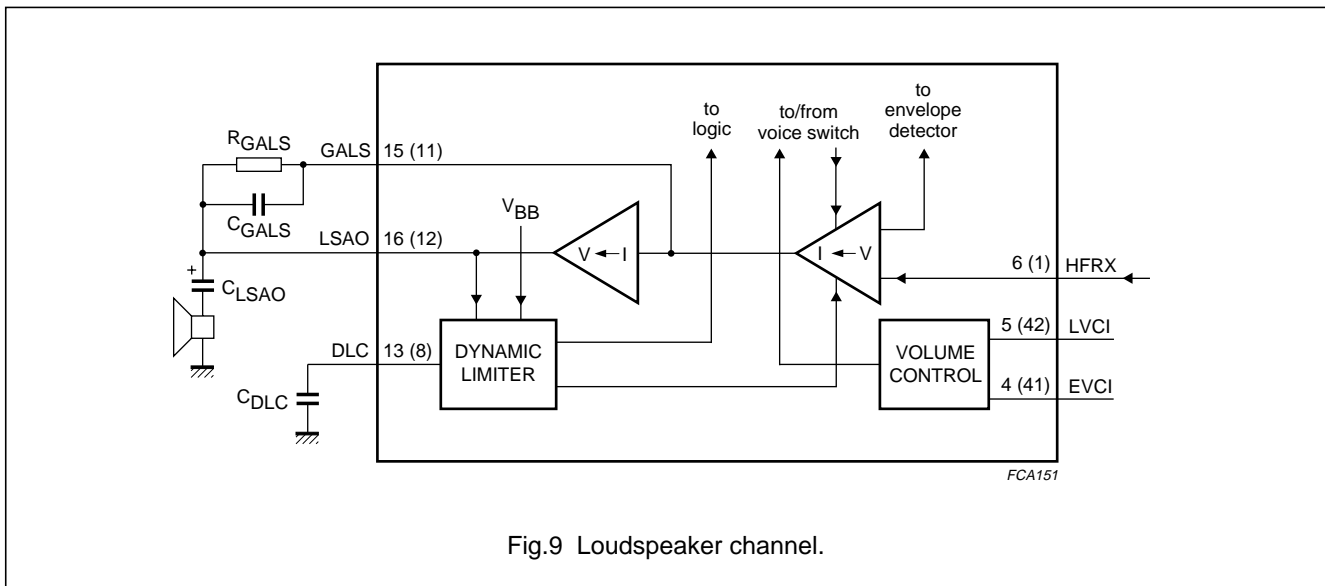

Speech and handsfree IC

TEA1098A

Loudspeaker amplifier (pins HFRX, GALS and LSAO)

The TEA1098A has an asymmetrical input for the loudspeaker amplifier with an input resistance of 20 k Ω between pins HFRX and GND. It is biased at two diodes voltage. Without limitation from the output, the input stage can accommodate signals up to 580 mV (RMS) at room temperature for 2% of THD.

The gain of the input stage varies according to the mode of the TEA1098A. In the receive mode, the gain is at its maximum; in the transmit mode, it is at its minimum and in the Idle mode, it is halfway between maximum and minimum. Switch-over from one mode to the other is smooth and click-free. The rail-to-rail output stage is designed to power a loudspeaker connected as a single-ended load (between pins LSAO and GND).

In the receive mode, the overall gain of the loudspeaker amplifier can be adjusted from 0 dB up to 35 dB to suit specific application requirements. The gain from HFRX to LSAO is proportional to the value of R_{GALS} and equals 28 dB with R_{GALS} = 255 k Ω . A capacitor connected in parallel with R_{GALS} is recommended and provides a first-order low-pass filter.

Digital volume control (pins LVCI and EVCI)

The loudspeaker amplifier gain can be adjusted (attenuated) with the LVCI logic input (as MSB) and the 4-level input EVCI (as LSBs). This combination provides 8 steps of -4 dB which applies in all handsfree receive modes.

Dynamic limiter (pin DLC)

The dynamic limiter of the TEA1098A prevents clipping of the loudspeaker output stage and protects the operation of the circuit when the supply voltage at V_{BB} falls below 2.7 V.

Hard clipping of the loudspeaker output stage is prevented by rapidly reducing the gain when the output stage starts to saturate. The time in which gain reduction is effected (clipping attack time) is approximately a few milliseconds. The circuit stays in the reduced gain mode until the peaks of the loudspeaker signals no longer cause saturation. The gain of the loudspeaker amplifier then returns to its normal value within the clipping release time (typically 250 ms). Both attack and release times are proportional to the value of the capacitor C_{DLC}. The total harmonic distortion of the loudspeaker output stage, in reduced gain mode, stays below 2% up to 10 dB (minimum) of input voltage overdrive [providing V_{HFRX} is below 580 mV (RMS)].

When the supply voltage drops below an internal threshold voltage of 2.7 V, the gain of the loudspeaker amplifier is rapidly reduced (approximately 1 ms). When the supply voltage exceeds 2.7 V, the gain of the loudspeaker amplifier is increased again.

By forcing a level lower than 0.2 V on pin DLC, the loudspeaker amplifier is muted and the TEA1098A is automatically forced into the transmit mode.

DUPLEX CONTROLLER

Signal and noise envelope detectors (pins TSEN, TENV, TNOI, RSEN, RENV and RNOI)

The signal envelopes are used to monitor the signal level strength in both channels. The noise envelopes are used to monitor background noise in both channels. The signal and noise envelopes provide inputs for the decision logic. The signal and noise envelope detectors are illustrated in Fig.10.

For the transmit channel, the input signal at pin TXI is 40 dB amplified to TSEN. For the receive channel, the input signal at pin HFRX is 0 dB amplified to RSEN. The signals from TSEN and RSEN are logarithmically compressed and buffered to TENV and RENV respectively.

The sensitivity of the envelope detectors is set with R_{TSEN} and R_{RSEN}. The capacitors connected in series with the two resistors block any DC component and form a first-order high-pass filter. In the basic application (see Fig.18) it is assumed that V_{TXI} = 1 mV (RMS) and V_{HFRX} = 100 mV (RMS) nominal and both R_{TSEN} and R_{RSEN} have a value of 10 k Ω . With the value of C_{TSEN} and C_{RSEN} at 100 nF, the cut-off frequency is at 160 Hz.

The buffer amplifiers feeding the compressed signals to pins TENV and RENV have a maximum source current of 120 μ A and a maximum sink current of 1 μ A. Capacitors C_{TENV} and C_{RENV} set the timing of the signal envelope monitors. In the basic application, the value of both capacitors is 470 nF. Because of the logarithmic compression, each 6 dB signal increase means 18 mV increase of the voltage on the envelopes TENV or RENV at room temperature. Thus, timings can be expressed in dB/ms. At room temperature, the 120 μ A sourced current corresponds to a maximum rise-slope of the signal envelope of 85 dB/ms. This is sufficient to track normal speech signals. The 1 μ A current sunk by TENV or RENV corresponds to a maximum fall-slope of 0.7 dB/ms. This is sufficient for a smooth envelope and also eliminates the effect of echoes on switching behaviour.

Speech and handsfree IC

TEA1098A

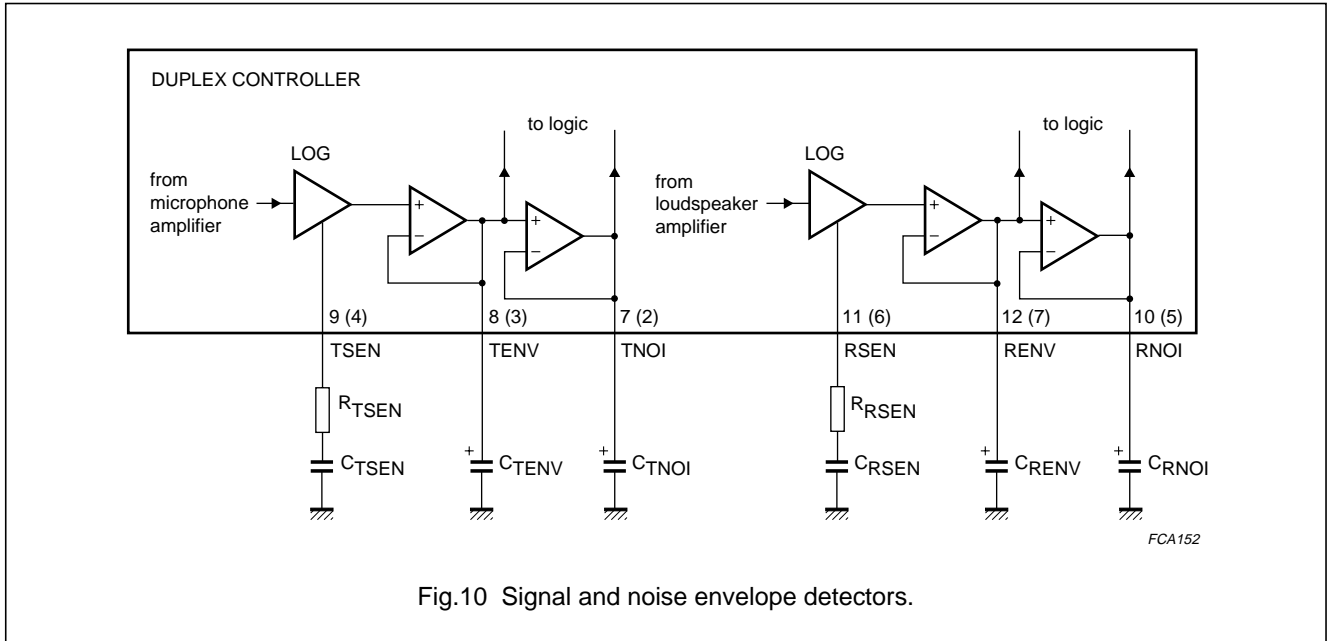

Fig.10 Signal and noise envelope detectors.

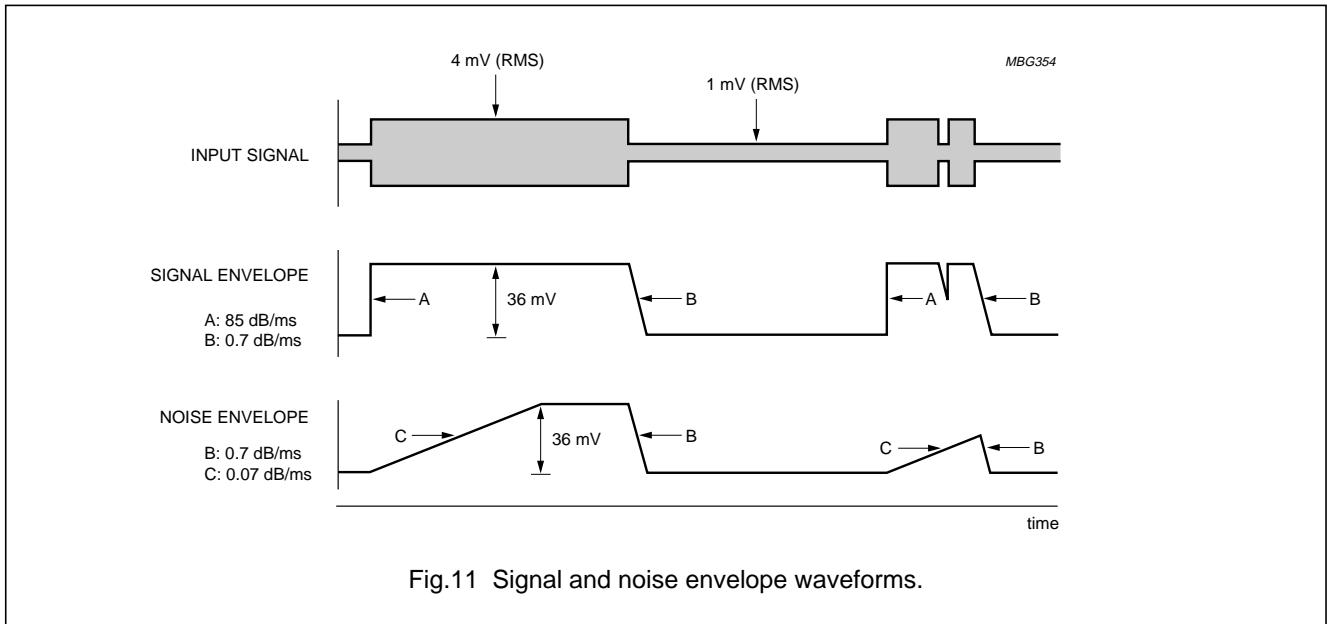

Fig.11 Signal and noise envelope waveforms.

To determine the noise level, the signals on pins TENV and RENV are buffered to pins TNOI and RNOI. These buffers have a maximum source current of 1 μ A and a maximum sink current of 120 μ A. Capacitors C_{TNOI} and C_{RNOI} set the timing. In the basic application, see Fig.18, the value of both capacitors is 4.7 μ F. At room temperature, the 1 μ A sourced current corresponds to a maximum rise-slope of the noise envelope of approximately 0.07 dB/ms.

This is small enough to track background noise and not to be influenced by speech bursts. The 120 μ A current that is sunk corresponds to a maximum fall-slope of approximately 8.5 dB/ms. However, during the decrease of the signal envelope, the noise envelope tracks the signal envelope so it will never fall faster than approximately 0.7 dB/ms. The behaviour of the signal envelope and noise envelope monitors is illustrated in Fig.11.

Speech and handsfree IC

TEA1098A

Decision logic (pins IDT and SWT)

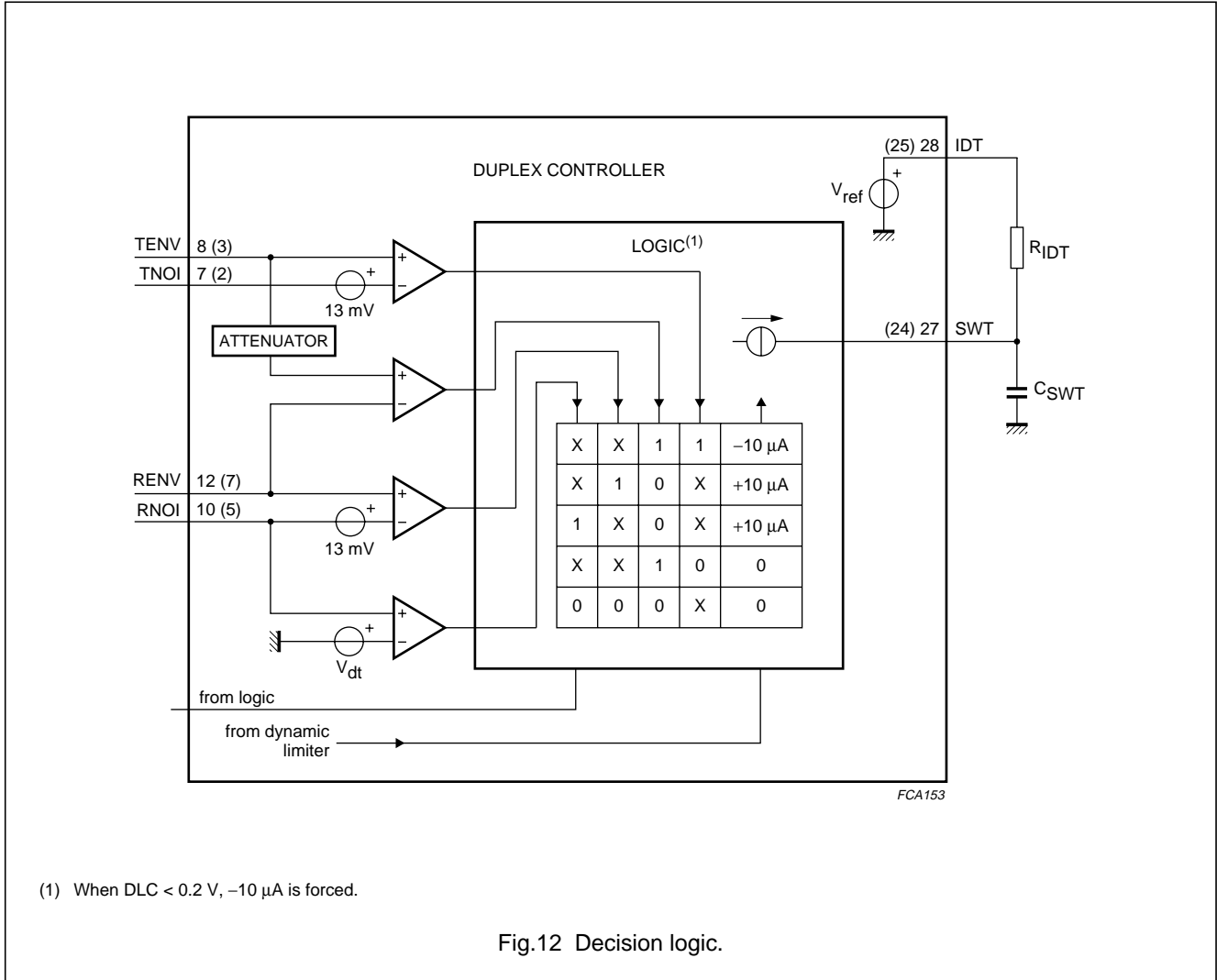

Fig.12 Decision logic.

The TEA1098A selects its mode of operation (transmit, receive or Idle mode) by comparing the signal and the noise envelopes of both channels. This is executed by the decision logic. The resulting voltage on pin SWT is the input for the voice-switch.

To facilitate the distinction between signal and noise, the signal is considered as speech when its envelope is more than 4.3 dB above the noise envelope. At room temperature, this is equal to a voltage difference $V_{ENV} - V_{NOI} = 13 mV$. This so-called speech/noise threshold is implemented in both channels.

The signal on pin TXI contains both speech and the signal from the loudspeaker (acoustic coupling). When receiving, the contribution from the loudspeaker overrules the speech.

As a result, the signal envelope on pin TENV is formed mainly by the loudspeaker signal. To correct this, an attenuator is connected between pin TENV and the TENV/RENV comparator. Its attenuation equals that applied to the microphone amplifier.

When a dial tone is present on the line, without monitoring, the tone would be recognized as noise because it is a signal with a constant amplitude. This would cause the TEA1098A to go into the Idle mode and the user of the set would hear the dial tone fade away. To prevent this, a dial tone detector is incorporated which, in standard applications, does not consider input signals between HFRX and GND as noise when they have a level greater than 25 mV (RMS). This level is proportional to R_{RSEN} .

Speech and handsfree IC

TEA1098A

In the same way, a transmit detector is integrated which, in standard applications, does not consider input signals between pins TXI and GNDTX as noise when they have a level greater than 0.75 mV (RMS). This level is proportional to R_{TSEN} .

As can be seen from Fig.12, the output of the decision logic is a current source. The logic table gives the relationship between the inputs and the value of the current source. It can charge or discharge the capacitor C_{SWT} with a current of 10 μ A (switch-over). If the current is zero, the voltage on pin SWT becomes equal to the voltage on pin IDT via the high-ohmic resistor R_{IDT} (idling). The resulting voltage difference between pins SWT and IDT determines the mode of the TEA1098A and can vary between -400 and +400 mV (see Table 1).

Table 1 Modes of TEA1098A

$V_{SWT} - V_{IDT}$ (mV)	MODE
<-180	transmit mode
0	Idle mode
>180	receive mode

The switch-over timing can be set with C_{SWT} , the Idle mode timing with C_{SWT} and R_{IDT} . In the basic application given in Fig.18, C_{SWT} is 220 nF and R_{IDT} is 2.2 M Ω . This enables a switch-over time from transmit to receive mode or vice-versa of approximately 13 ms (580 mV swing on pin SWT). The switch-over time from Idle mode to transmit mode or receive mode is approximately 4 ms (180 mV swing on pin SWT).

The switch-over time, from receive mode or transmit mode to Idle mode is equal to $4 \times R_{IDT}C_{SWT}$ and is approximately 2 seconds (Idle mode time).

The input at pin DLC overrules the decision logic. When the voltage on pin DLC goes lower than 0.2 V, the capacitor C_{SWT} is discharged with 10 μ A thus resulting in the transmit mode.

Voice-switch (pins STAB and SWR)

A diagram of the voice-switch is illustrated in Fig.13. With the voltage on pin SWT, the TEA1098A voice-switch regulates the gains of the transmit and the receive channels so that the sum of both is kept constant.

In the transmit mode, the gain of the microphone amplifier is at its maximum and the gain of the loudspeaker amplifier is at its minimum. In the receive mode, the opposite applies. In the Idle mode, both microphone and loudspeaker amplifier gains are halfway.

The difference between maximum and minimum is the so called switching range. This range is determined by the ratio of R_{SWR} and R_{STAB} and is adjustable between 0 and 52 dB. R_{STAB} should be 3.65 k Ω and sets an internally used reference current. In the basic application diagram given in Fig.18, R_{SWR} is 365 k Ω which results in a switching range of 40 dB. The switch-over behaviour is illustrated in Fig.14.

In the receive mode, the gain of the loudspeaker amplifier can be reduced using the volume control. Since the voice-switch keeps the sum of the gains constant, the gain of the microphone amplifier is increased at the same time (see dashed curves in Fig.14). In the transmit mode, however, the volume control has no influence on the gain of the microphone amplifier or the gain of the loudspeaker amplifier. Consequently, the switching range is reduced when the volume is reduced. At maximum reduction of volume, the switching range becomes 0 dB.

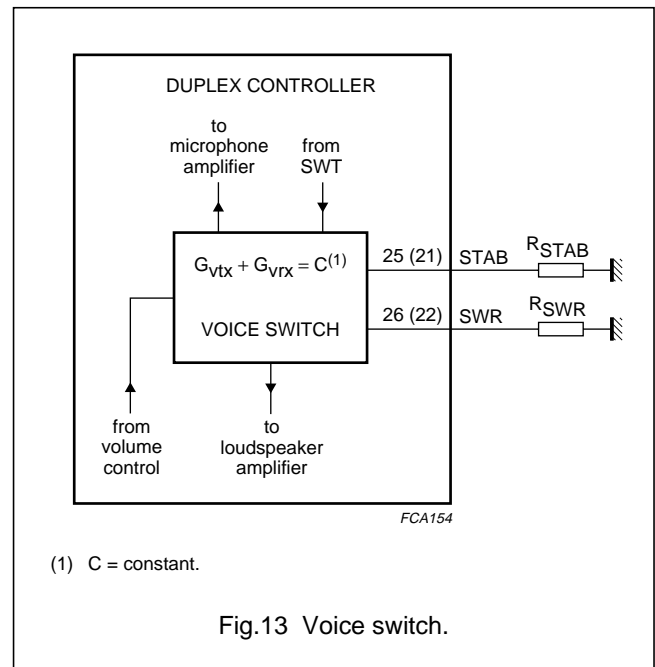

Speech and handsfree IC

TEA1098A

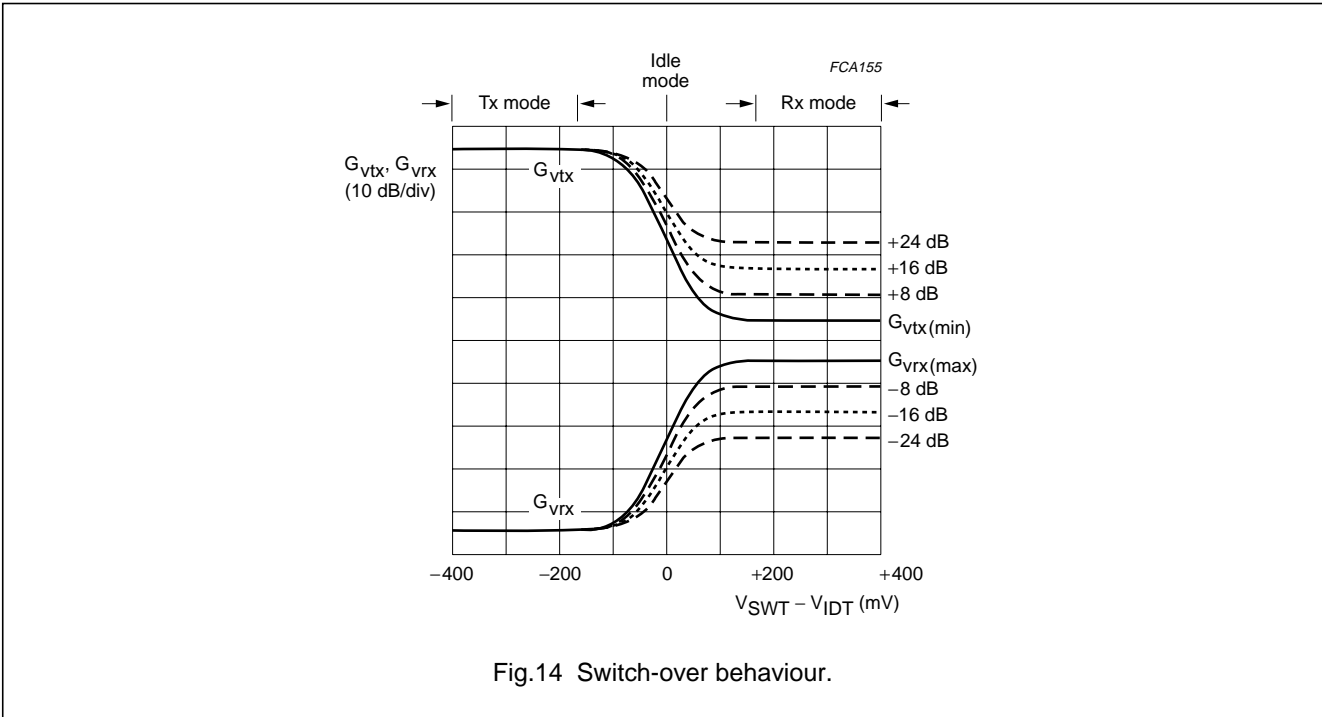

Fig.14 Switch-over behaviour.

Logic inputs

The actions of the logic inputs \overline{BPC} and \overline{MUTE} , combined with the HFC input are detailed in the Table 2.

Table 2 Table of switch management

LOGIC INPUTS			FEATURES	APPLICATION
HFC	MUTE	BPC		
0	0	0	DTMF to RECO; RECO to EARO; MICS is active	handset beep mode
0	0	1	DTMF to LN; DTMF to RECO; RECO to EARO; MICS is active	handset dialling mode
0	1	0	IR to RECO; RECO to EARO; MICS is active	handset secret mode
0	1	1	MIC to LN; IR to RECO; RECO to EARO; MICS is active	handset conversation mode
1	0	0	DTMF to RECO; HFRX to LSAO; MICS is active	handsfree beep mode
1	0	1	DTMF to LN; DTMF to RECO; HFRX to LSAO; MICS is active	handsfree dialling mode
1	1	0	IR to RECO; HFRX to LSAO; MICS is active	handsfree secret mode
1	1	1	TXI to TXO; HFTX to LN; IR to RECO; HFRX to LSAO; MICS is active	handsfree conversation mode

Speech and handsfree IC

TEA1098A

LIMITING VALUES

SYMBOL	PARAMETER	CONDITIONS	MIN.	MAX.	UNIT
V_{LN}	positive continuous line voltage		-0.4	12	V
	repetitive line voltage during switch-on or line interruption		-0.4	13.2	V
$V_{n(max)}$	maximum voltage on pins REG, SLPE, IR and AGC		-0.4	$V_{LN} + 0.4$	V
	maximum voltage on all other pins except V_{DD}		-0.4	$V_{BB} + 0.4$	V
I_{line}	maximum line current		-	130	mA
P_{tot}	total power dissipation	$T_{amb} = 75\text{ °C}$			
	TEA1098ATV (see Fig.15)		-	400	mW
	TEA1098AH (see Fig.16)		-	720	mW
T_{stg}	IC storage temperature		-40	+125	°C
T_{amb}	ambient temperature		-25	+75	°C

THERMAL CHARACTERISTICS

SYMBOL	PARAMETER	CONDITIONS	VALUE	UNIT
$R_{th(j-a)}$	thermal resistance from junction to ambient	in free air		
	TEA1098ATV		117	K/W
	TEA1098AH		66	K/W

Speech and handsfree IC

TEA1098A

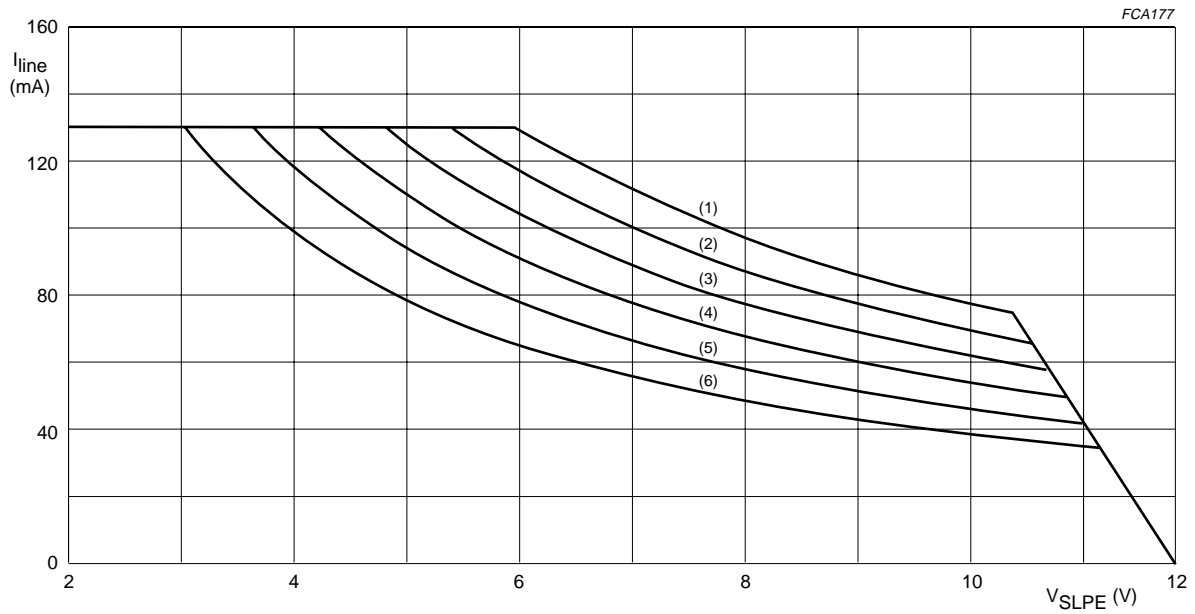

LINE	T _{amb} (°C)	P _{tot} (mW)
(1)	25	790
(2)	35	710
(3)	45	630
(4)	55	550
(5)	65	470
(6)	75	390

Fig.15 Safe operating area (TEA1098ATV)

Speech and handsfree IC

TEA1098A

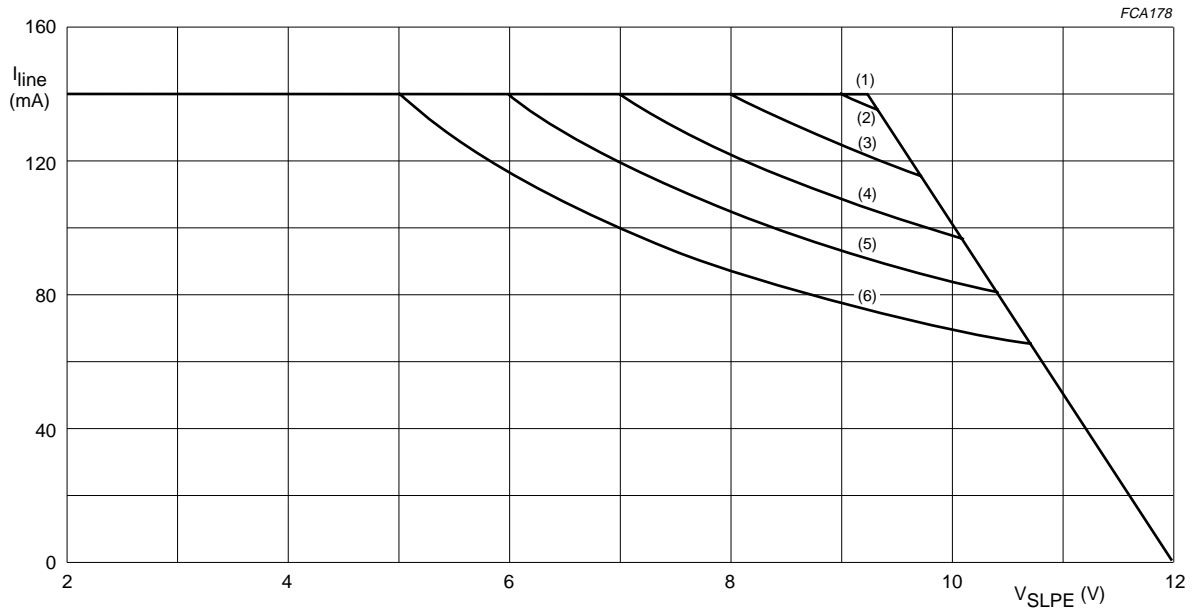

LINE	T _{amb} (°C)	P _{tot} (mW)
(1)	25	1290
(2)	35	1250
(3)	45	1110
(4)	55	975
(5)	65	835
(6)	75	695

Fig.16 Safe operating area (TEA1098AH).

Speech and handsfree IC

TEA1098A

CHARACTERISTICS

$I_{line} = 15 \text{ mA}$; $R_{SLPE} = 20 \ \Omega$; $Z_{line} = 600 \ \Omega$; $f = 1 \text{ kHz}$; $T_{amb} = 25 \text{ }^\circ\text{C}$; AGC pin connected to LN; $\overline{PD} = \text{HIGH}$; HFC = LOW; MUTE = HIGH; $\overline{BPC} = \text{HIGH}$; all DC levels are referenced to GND; unless otherwise specified.

SYMBOL	PARAMETER	CONDITIONS	MIN.	TYP.	MAX.	UNIT
Supplies						
LINE INTERFACE AND INTERNAL SUPPLY (PINS LN, SLPE, REG AND V_{BB})						
V_{SLPE}	stabilized voltage between SLPE and GND	$I_{line} = 15 \text{ mA}$	3.4	3.7	4	V
		$I_{line} = 70 \text{ mA}$	5.7	6.1	6.5	V
V_{REF}	stabilized voltage with an external resistor R_{VA} between REG and SLPE	$R_{VA} = 40 \text{ k}\Omega$	–	4.5	–	V
$\Delta V_{REF}(T)$	stabilized voltage variation with temperature referenced to $25 \text{ }^\circ\text{C}$	$T_{amb} = -25 \text{ to } +75 \text{ }^\circ\text{C}$	–	± 60	–	mV
V_{LN}	line voltage	$I_{line} = 1 \text{ mA}$	–	1.55	–	V
		$I_{line} = 4 \text{ mA}$	–	2.35	–	V
		$I_{line} = 15 \text{ mA}$	3.7	4.0	4.3	V
		$I_{line} = 130 \text{ mA}$	–	8.7	9.3	V
V_{BB}	regulated supply voltage for internal circuitry	$I_{line} = 15 \text{ mA}$; $I_{V_{BB}} = 0$	2.75	3.0	3.25	V
		$I_{line} = 70 \text{ mA}$; $I_{V_{BB}} = 0$	4.9	5.3	5.7	V
I_{line}	line current for voltage increase	start current	–	18	–	mA
		stop current	–	45	–	mA
$\Delta V_{BB}(T)$	regulated voltage variation with temperature referenced to $25 \text{ }^\circ\text{C}$	$T_{amb} = -25 \text{ to } +75 \text{ }^\circ\text{C}$	–	± 30	–	mV
I_{BB}	current available on pin V_{BB}	in speech mode	–	11	–	mA
		in handsfree mode	–	9	–	mA
SUPPLY FOR PERIPHERALS (PIN V_{DD})						
V_{DD}	supply output voltage	$V_{BB} > 3.35 \text{ V} + 0.25 \text{ V (typ.)}$	3.1	3.35	3.6	V
		otherwise	–	$V_{BB} - 0.25$	–	V
$\Delta V_{DD}(T)$	regulated voltage variation with temperature referenced to $25 \text{ }^\circ\text{C}$	$T_{amb} = -25 \text{ to } +75 \text{ }^\circ\text{C}$; $V_{BB} > 3.35 \text{ V} + 0.25 \text{ V (typ.)}$	–	± 30	–	mV
I_{DD}	current consumption on V_{DD}	in trickle mode; $I_{line} = 0 \text{ mA}$; $V_{DD} = 1.5 \text{ V}$; V_{BB} discharging	–	15	150	nA
$I_{V_{DD}}$	current sunk from external source	in ringer mode; $I_{line} = 0$; $V_{DD} = 3.35 \text{ V}$	–	–	75	mA

Speech and handsfree IC

TEA1098A

SYMBOL	PARAMETER	CONDITIONS	MIN.	TYP.	MAX.	UNIT
$I_{DD(O)}$	current available for peripherals	$V_{DD} = 3.3 \text{ V}$	–	–3	–	mA
SUPPLY FOR MICROPHONE (PIN MICS)						
V_{MICS}	supply voltage for a microphone		–	2.0	–	V
POWER-DOWN INPUT (PIN \overline{PD})						
V_{IL}	LOW-level input voltage		–0.4	–	0.3	V
$I_{i(PD)(l)}$	input current at low voltage		–	–3	–6	μA
V_{IH}	HIGH-level input voltage		1.4	–	$V_{BB} + 0.3$	V
$I_{BB(PD)}$	current consumption on V_{BB} during power-down phase	$\overline{PD} = \text{LOW}$	–	460	–	μA
Preamplifier inputs (pins MIC+, MIC–, IR, DTMF, TXI, HFTX and HFRX)						
$ Z_{i(MIC)} $	input impedance differential between pins MIC+ and MIC–		–	70	–	$\text{k}\Omega$
	input impedance single-ended between pins MIC+/MIC– and GNCTX		–	35	–	$\text{k}\Omega$
$ Z_{i(IR)} $	input impedance between pins IR and LN		–	20	–	$\text{k}\Omega$
$ Z_{i(DTMF)} $	input impedance between pins DTMF and GND		–	20	–	$\text{k}\Omega$
$ Z_{i(TXI)} $	input impedance between pins TXI and GNCTX		–	20	–	$\text{k}\Omega$
$ Z_{i(HFTX)} $	input impedance between pins HFTX and GND		–	20	–	$\text{k}\Omega$
$ Z_{i(HFRX)} $	input impedance between pins HFRX and GND		–	20	–	$\text{k}\Omega$
TX amplifiers						
TX HANDSET MICROPHONE AMPLIFIER (PINS MIC+, MIC– AND LN)						
$G_{V(MIC-LN)}$	voltage gain from pin MIC+/MIC– to LN	$V_{MIC} = 5 \text{ mV (RMS)}$	43.3	44.3	45.3	dB
$\Delta G_{V(f)}$	gain variation with frequency referenced to 1 kHz	$f = 300 \text{ to } 3400 \text{ Hz}$	–	± 0.25	–	dB

Speech and handsfree IC

TEA1098A

SYMBOL	PARAMETER	CONDITIONS	MIN.	TYP.	MAX.	UNIT
$\Delta G_{V(T)}$	gain variation with temperature referenced to 25 °C	$T_{amb} = -25$ to $+75$ °C	–	± 0.25	–	dB
CMRR	common mode rejection ratio		–	80	–	dB
THD	total harmonic distortion at LN	$V_{LN} = 1.4$ V (RMS)	–	–	2	%
		$I_{line} = 4$ mA; $V_{LN} = 0.12$ V (RMS)	–	–	10	%
$V_{no(LN)}$	noise output voltage at pin LN; pins MIC+/MIC– shorted through 200 Ω	psophometrically weighted (p53 curve)	–	–77	–	dBmp
$\Delta G_{V(mute)}$	gain reduction when muted	$\overline{MUTE} = 0$; see Table 2	60	80	–	dB
$\Delta G_{V(MIC)(mute)}$	gain reduction in microphone mute mode	$V_{MIC} = 10$ mV (RMS); $\overline{MUTE} = 1$; $\overline{BPC} = 0$; see Table 2	60	–	–	dB
DTMF AMPLIFIER (PINS DTMF, LN AND RECO)						
$G_{V(DTMF-LN)}$	voltage gain from pin DTMF to LN	$V_{DTMF} = 50$ mV (RMS)	24.35	25.35	26.35	dB
$\Delta G_{V(f)}$	gain variation with frequency referenced to 1 kHz	$f = 300$ to 3400 Hz	–	± 0.25	–	dB
$\Delta G_{V(T)}$	gain variation with temperature referenced to 25 °C	$T_{amb} = -25$ to $+75$ °C	–	± 0.25	–	dB
$\Delta G_{V(mute)}$	gain reduction if not active	$\overline{MUTE} = 1$; see Table 2	60	80	–	dB
$G_{V(DTMF-RECO)}$	voltage gain from pin DTMF to RECO in handsfree mode	$V_{DTMF} = 50$ mV (RMS); $\overline{MUTE} = 0$; HFC = 1	–	–17	–	dB
$G_{V(DTMF-RECO)}$	voltage gain from pin DTMF to RECO in handset mode	$V_{DTMF} = 50$ mV (RMS); $\overline{MUTE} = 0$; HFC = 0; EVCI = 0	–	–28.2	–	dB
$\Delta G_{V(DTMF-RECO)}$	digital volume control adjustment range in handset mode	$V_{DTMF} = 50$ mV (RMS); $\overline{MUTE} = 0$; HFC = 0	–	–12.75	–	dB
$\Delta G_{V(DTMF-RECO)}$	digital volume control adjustment step in handset mode	$\overline{MUTE} = 0$; HFC = 0; per step	–	+4.25	–	dB

Speech and handsfree IC

TEA1098A

SYMBOL	PARAMETER	CONDITIONS	MIN.	TYP.	MAX.	UNIT
TX AMPLIFIER USING HFTX (PINS HFTX AND LN)						
$G_{V(\text{HFTX-LN})}$	voltage gain from pin HFTX to LN	$V_{\text{HFTX}} = 15 \text{ mV (RMS)}$	33.5	34.7	35.9	dB
$\Delta G_{V(f)}$	gain variation with frequency referenced to 1 kHz	$f = 300 \text{ to } 3400 \text{ Hz}$	–	± 0.25	–	dB
$\Delta G_{V(T)}$	gain variation with temperature referenced to 25 °C	$T_{\text{amb}} = -25 \text{ to } +75^\circ\text{C}$	–	± 0.35	–	dB
THD	total harmonic distortion at LN	$V_{\text{LN}} = 1.4 \text{ V (RMS)}$	–	–	2	%
$V_{\text{HFTX(rms)}}$	maximum input voltage at HFTX (RMS value)	$I_{\text{line}} = 70 \text{ mA}; \text{THD} = 2\%$	–	85	–	mV
$V_{\text{no(LN)}}$	noise output voltage at pin LN; pin HFTX shorted to GND through 200 Ω in series with 10 μF	psophometrically weighted (p53 curve)	–	–77	–	dBmp
$\Delta G_{V(m)}$	gain reduction when muted	$\overline{\text{MUTE}} = 0$; see Table 2	60	80	–	dB
$\Delta G_{V(\text{MIC})(\text{mute})}$	gain reduction in microphone mute mode	$\overline{\text{MUTE}} = 1$; $\overline{\text{BPC}} = 0$; see Table 2	60	–	–	dB
RX amplifiers						
RX AMPLIFIERS USING IR (PINS IR AND RECO)						
$G_{V(\text{IR-RECO})(\text{HF})}$	voltage gain from IR to RECO (handsfree mode)	$V_{\text{IR}} = 4 \text{ mV (RMS)}; \text{HFC} = 1$	28.4	29.4	30.4	dB
$G_{V(\text{IR-RECO})(\text{HS})}$	voltage gain from IR to RECO (handset mode)	$V_{\text{IR}} = 4 \text{ mV (RMS)}; \text{HFC} = 0$; $\text{EVCI} = 0$	16.2	17.2	18.2	dB
$\Delta G_{V(\text{IR-RECO})}$	digital volume control adjustment range in handset mode	$V_{\text{IR}} = 4 \text{ mV (RMS)}; \text{HFC} = 0$; $\text{EVCI} = V_{\text{DD}}$	13	14.5	16	dB
$\Delta G_{V(\text{IR-RECO})}$	digital volume control adjustment step in handset mode	$\text{HFC} = 0$; per step	–	+4.85	–	dB
$\Delta G_{V(f)}$	gain variation with frequency referred to 1 kHz	$f = 300 \text{ to } 3400 \text{ Hz}$	–	± 0.25	–	dB
$\Delta G_{V(T)}$	gain variation with temperature referenced to 25 °C	$T_{\text{amb}} = -25 \text{ to } +75^\circ\text{C}$	–	± 0.3	–	dB
$V_{\text{IR(rms)(max)}}$	maximum input voltage on IR (referenced to LN) (RMS value)	$I_{\text{line}} = 70 \text{ mA}; \text{THD} = 2\%$	–	50	–	mV

Speech and handsfree IC

TEA1098A

SYMBOL	PARAMETER	CONDITIONS	MIN.	TYP.	MAX.	UNIT
$V_{RECO(rms)(max)}$	maximum output voltage on RECO (RMS value)	THD = 2%; $G_{V(RECO-EARO)} = 12$ dB	0.75	0.9	–	V
$V_{no(RECO)(rms)}$	noise output voltage at pin RECO; pin IR is an open-circuit (RMS value)	psophometrically weighted (p53 curve)	–	–84	–	dBVp
$\Delta G_{V(mute)}$	gain reduction if not active	$\overline{MUTE} = 0$; see Table 2	60	80	–	dB
RX EARPIECE AMPLIFIER (PINS GARX AND EARO)						
$\Delta G_{V(RECO-EARO)}$	gain voltage range between pins RECO and EARO		0	–	+20	dB
$V_{EARO(rms)(max)}$	maximum output voltage on EARO (RMS value)	sine wave drive; $R_L = 150 \Omega$; THD < 2%	0.75	0.9	–	V
$V_{no(EARO)(rms)}$	noise output voltage at pin EARO; pin IR is an open-circuit (RMS value)	$G_{V(EARO)} = 12$ dB; $EVCI = 0$; psophometrically weighted (p53 curve)	–	–84	–	dBVp
Automatic Gain Control (pin AGC)						
$\Delta G_{V(trx)}$	gain control range for transmit and receive signals affected by the AGC; with respect to $I_{line} = 15$ mA	$I_{line} = 70$ mA; $G_{V(MIC-LN)}$; $G_{V(IR-RECO)}$; $R_{AGC} = 0$;	5.45	6.45	7.45	dB
		$I_{line} = 70$ mA for $G_{V(HFTX-LN)}$; $R_{AGC} = 0$	5.8	6.8	7.8	dB
I_{start}	highest line current for maximum gain		–	23	–	mA
I_{stop}	lowest line current for maximum gain		–	57	–	mA
ΔI_{start}	I_{start} adjustment range with R_{AGC}		–	–	40	mA
Logic inputs (pins HFC, MUTE, and BPC)						
V_{IL}	LOW-level input voltage		–0.4	–	0.3	V
V_{IH}	HIGH-level input voltage		1.4	–	$V_{BB} + 0.3$	V
$I_{i(l)}$	input current at low voltage	$V_{BB} = 3.0$ V				
	for pin HFC		–	0	–	μ A
	for pin \overline{MUTE}		–	–5	–	μ A
	for pin \overline{BPC}		–	–2.5	–	μ A

Speech and handsfree IC

TEA1098A

SYMBOL	PARAMETER	CONDITIONS	MIN.	TYP.	MAX.	UNIT
$I_{i(h)}$	input current at high voltage	$V_{BB} = 3.0\text{ V}$				
	for pin HFC		–	2.5	–	μA
	for pin $\overline{\text{MUTE}}$		–	0	–	μA
	for pin $\overline{\text{BPC}}$		–	0	–	μA
Handsfree mode (HFC = HIGH)						
HF MICROPHONE AMPLIFIER (PINS TXI, TXO AND GATX)						
$G_{V(\text{TXI-TXO})}$	voltage gain from pin TXI to TXO	$V_{\text{TXI}} = 3\text{ mV (RMS)}$; $R_{\text{GATX}} = 30.1\text{ k}\Omega$	12.7	15.2	17.7	dB
ΔG_V	voltage gain adjustment with R_{GATX}		–15	–	+16	dB
$\Delta G_{V(f)}$	gain variation with frequency referenced to 1 kHz	$f = 300\text{ to }3400\text{ Hz}$	–	± 0.1	–	dB
$\Delta G_{V(T)}$	gain variation with temperature referenced to 25 °C	$T_{\text{amb}} = -25\text{ to }+75\text{ }^\circ\text{C}$	–	± 0.15	–	dB
$V_{\text{no(TXO)(rms)}}$	noise output voltage at pin TXO; pin TXI is shorted through 200 Ω and 10 μF to GNDTX	psophometrically weighted (p53 curve); $G_{V(\text{TXI})} = 15\text{ dB}$; RMS value	–	–101	–	dBVp
$\Delta G_{V(\text{mute})}$	gain reduction when muted	$\overline{\text{MUTE}} = 0$; see Table 2	60	80	–	dB
$\Delta G_{V(\text{SEC})}$	gain reduction in SECRET mode	$V_{\text{txi}} = 10\text{ mV (RMS)}$; $\overline{\text{MUTE}} = 1$; $\text{BPC} = 0$; see Table 2	60	–	–	dB
HF LOUDSPEAKER AMPLIFIER (PINS HFRX, LSAO, GALS AND DLC)						
$G_{V(\text{HFRX-LSAO})}$	nominal voltage gain from pin HFRX to LSAO	$V_{\text{HFRX}} = 30\text{ mV (RMS)}$; $R_{\text{GALS}} = 255\text{ k}\Omega$; $\text{LVCI} = V_{\text{DD}}$; $\text{EVCI} = V_{\text{DD}}$	24.5	27	29.5	dB
$\Delta G_{V(\text{HFRX-LSAO})}$	digital volume control adjustment range	$V_{\text{HFRX}} = 30\text{ mV (RMS)}$; $R_{\text{GALS}} = 255\text{ k}\Omega$	25.5	27	28.5	dB
$\Delta G_{V(\text{step})}$	digital volume adjustment step	per step	–	3.85	–	dB
ΔG_V	voltage gain adjustment with R_{GALS}		–28	–	+7	dB
$\Delta G_{V(f)}$	gain variation with frequency referenced to 1 kHz	$f = 300\text{ to }3400\text{ Hz}$	–	± 0.3	–	dB
$\Delta G_{V(T)}$	gain variation with temperature referenced to 25 °C	$T_{\text{amb}} = -25\text{ to }+75\text{ }^\circ\text{C}$	–	± 0.3	–	dB
$V_{\text{HFRX(rms)(max)}}$	maximum input voltage at pin HFRX (RMS value)	$I_{\text{line}} = 70\text{ mA}$; $R_{\text{GALS}} = 33\text{ k}\Omega$; for 2% THD in the input stage	–	580	–	mV

Speech and handsfree IC

TEA1098A

SYMBOL	PARAMETER	CONDITIONS	MIN.	TYP.	MAX.	UNIT
$V_{no(LSAO)(rms)}$	noise output voltage at pin LSAO; pin HFRX is open-circuit (RMS value)	psophometrically weighted (p53 curve); LVCI = V_{DD} ; EVCI = V_{DD}	–	–79	–	dBVp
$\Delta G_{V(mute)}$	gain reduction if not active	see Table 2	60	–	–	dB
$V_{LSAO(rms)}$	output voltage capability at pin LSAO with sine wave signal and loaded with $50 \Omega + 220 \mu F$; $G_{V(LSAO)} = 28 \text{ dB}$	$I_{BB} = 1 \text{ mA}$; $I_{DD} = 1 \text{ mA}$ $I_{line} = 18 \text{ mA}$ $I_{line} = 30 \text{ mA}$ $I_{line} > 50 \text{ mA}$	– – –	– 0.9 1.3 1.6	– – – –	V V V
$I_{LSAO(max)}$	maximum output current at pin LSAO (peak value)		150	300	–	mA
DYNAMIC LIMITER (PINS LSAO AND DLC)						
t_{att}	attack time	when V_{HFRX} jumps up from 20 mV to 20 mV +10 dB	–	–	5	ms
		when V_{BB} drops below $V_{BB(th)}$	–	1	–	ms
t_{rel}	release time	when V_{HFRX} jumps down from 20 mV +10 dB to 20 mV	–	100	–	ms
THD	total harmonic distortion	$V_{HFRX} = 20 \text{ mV} + 10 \text{ dB}$; $G_{V(LSAO)} = 28 \text{ dB}$; $t > t_{att}$	–	1	2	%
$V_{BB(th)}$	V_{BB} limiter threshold		–	2.7	–	V
MUTE RECEIVE (PIN DLC)						
$V_{DLC(th)}$	threshold voltage required on pin DLC to obtain mute receive condition		–	–	0.2	V
$I_{DLC(th)}$	Start-up current sourced by pin DLC	$V_{DLC} = 0.2 \text{ V}$	–	100	–	μA
$\Delta G_{Vrx(m)}$	voltage gain reduction in mute receive condition	$V_{DLC} = 0.2 \text{ V}$	60	80	–	dB
TX AND RX ENVELOPE AND NOISE DETECTORS (PINS TSEN, TENV, TNOI, RSEN, RENV AND RNOI)						
<i>Preamplifiers</i>						
$G_{V(TSEN)}$	voltage gain from pin TXI to TSEN		–	40	–	dB
$G_{V(RSEN)}$	voltage gain from pin HFRX to RSEN		–	0	–	dB

Speech and handsfree IC

TEA1098A

SYMBOL	PARAMETER	CONDITIONS	MIN.	TYP.	MAX.	UNIT
<i>Logarithmic compressor and sensitivity adjustment</i>						
$\Delta V_{\text{det(TSEN)}}$	sensitivity detection on pin TSEN; voltage change on pin TENV when doubling the current from TSEN	$I_{\text{TSEN}} = 0.8$ to $160 \mu\text{A}$	–	18	–	mV
$\Delta V_{\text{det(RSEN)}}$	sensitivity detection on pin RSEN; voltage change on pin RENV when doubling the current from RSEN	$I_{\text{RSEN}} = 0.8$ to $160 \mu\text{A}$	–	18	–	mV
<i>Signal envelope detectors</i>						
$I_{\text{source(ENV)}}$	maximum current sourced from pin TENV or RENV		–	120	–	μA
$I_{\text{sink(ENV)}}$	maximum current sunk by pin TENV or RENV		–1.25	–1	–0.75	μA
ΔV_{ENV}	voltage difference between RENV and TENV	$10 \mu\text{A}$ sourced from both RSEN and TSEN; signal detectors tracking; note 1	–	± 3	–	mV
<i>Noise envelope detectors</i>						
$I_{\text{source(NOI)}}$	maximum current sourced from pin TNOI or RNOI		0.75	1	1.25	μA
$I_{\text{sink(NOI)}}$	maximum current sunk by pin TNOI or RNOI		–	–120	–	μA
ΔV_{NOI}	voltage difference between pins RNOI and TNOI	when $5 \mu\text{A}$ is sourced from both RSEN and TSEN; noise detectors tracking; note 1	–	± 3	–	mV
DIAL TONE DETECTOR						
$V_{\text{HFRX(th)(rms)}}$	threshold level at pin HFRX (RMS value)	$R_{\text{RSEN}} = 10 \text{ k}\Omega$; $C_{\text{RSEN}} = 100 \text{ nF}$	–	25	–	mV
TX LEVEL LIMITER						
$V_{\text{TXI(th)(rms)}}$	threshold level at pin TXI (RMS value)	$R_{\text{TSEN}} = 10 \text{ k}\Omega$	–	0.75	–	mV
DECISION LOGIC (PINS IDT AND SWT)						
<i>Signal recognition</i>						
$\Delta V_{\text{Strx(th)}}$	threshold voltage between RENV/RNOI or between TENV/TNOI to switch-over from Idle mode to RX/TX mode	$V_{\text{HFRX}} < V_{\text{HFRX(th)}}$; $V_{\text{TXI}} < V_{\text{TXI(th)}}$; note 2	–	13	–	mV

Speech and handsfree IC

TEA1098A

SYMBOL	PARAMETER	CONDITIONS	MIN.	TYP.	MAX.	UNIT
<i>Switch-over</i>						
$I_{\text{source(SWT)}}$	current sourced from pin SWT when switching to receive mode		7.5	10	12.5	μA
$I_{\text{sink(SWT)}}$	current sunk by pin SWT when switching to transmit mode		-12.5	-10	-7.5	μA
$I_{\text{idle(SWT)}}$	current sourced from pin SWT in Idle mode		-	0	-	μA
VOICE SWITCH (PINS STAB AND SWR)						
SWR	switching range		-	40	-	dB
ΔSWR	switching range adjustment	with R_{SWR} referenced to 365 k Ω	-40	-	+12	dB
$ \Delta G_v $	voltage gain variation from active modes to Idle mode	SWRA = 40 dB	-	± 20	-	dB
G_{tr}	gain tracking ($G_{\text{vtx}} + G_{\text{vrx}}$) during switching, referred to Idle mode		-	± 0.5	-	dB

Notes

1. Corresponds to ± 1 dB tracking.
2. Corresponds to 4.3 dB noise/speech recognition level.

Speech and handsfree IC

TEA1098A

TEST AND APPLICATION INFORMATION

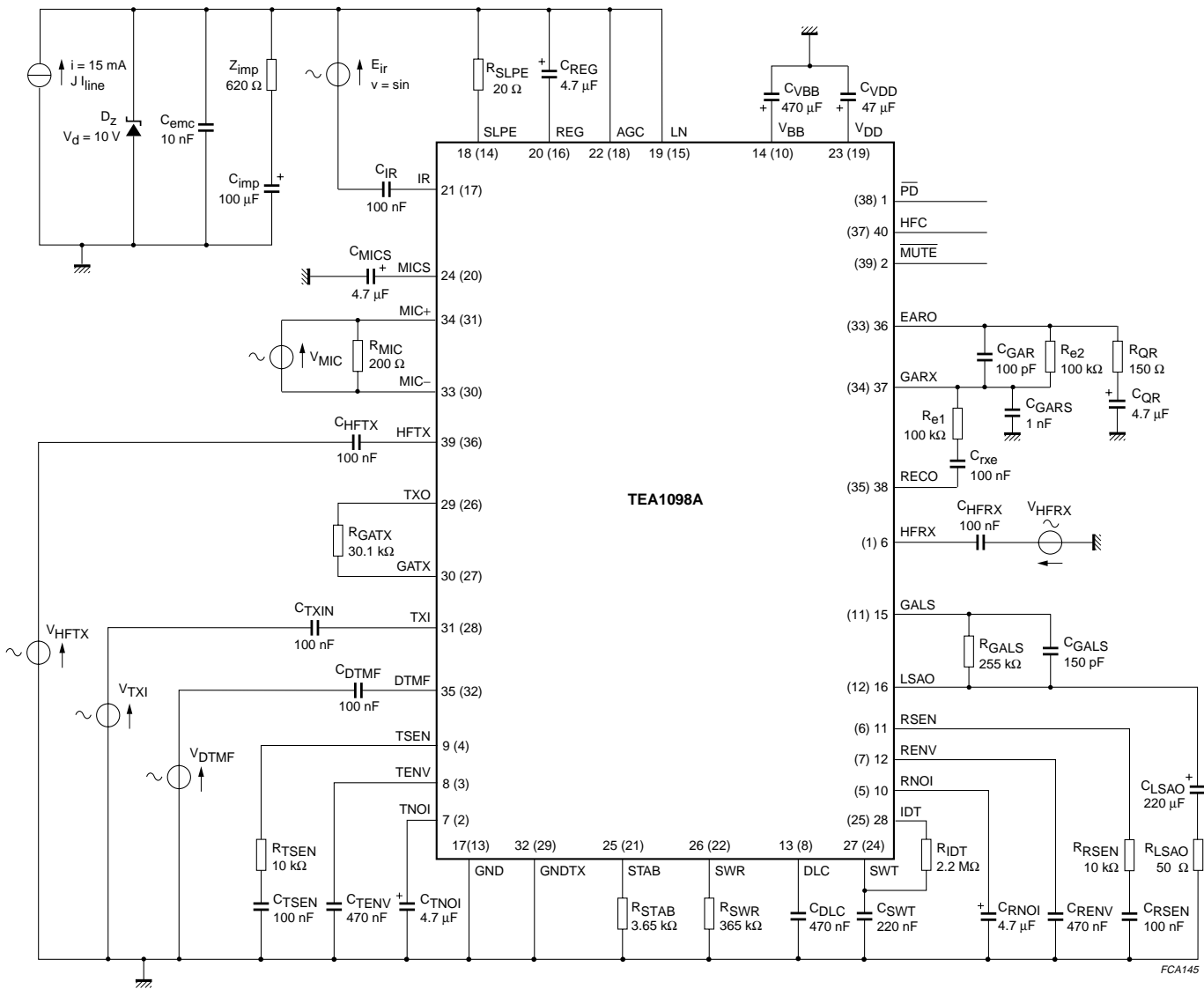

Fig.17 Test configuration.

Speech and handsfree IC

TEA1098A

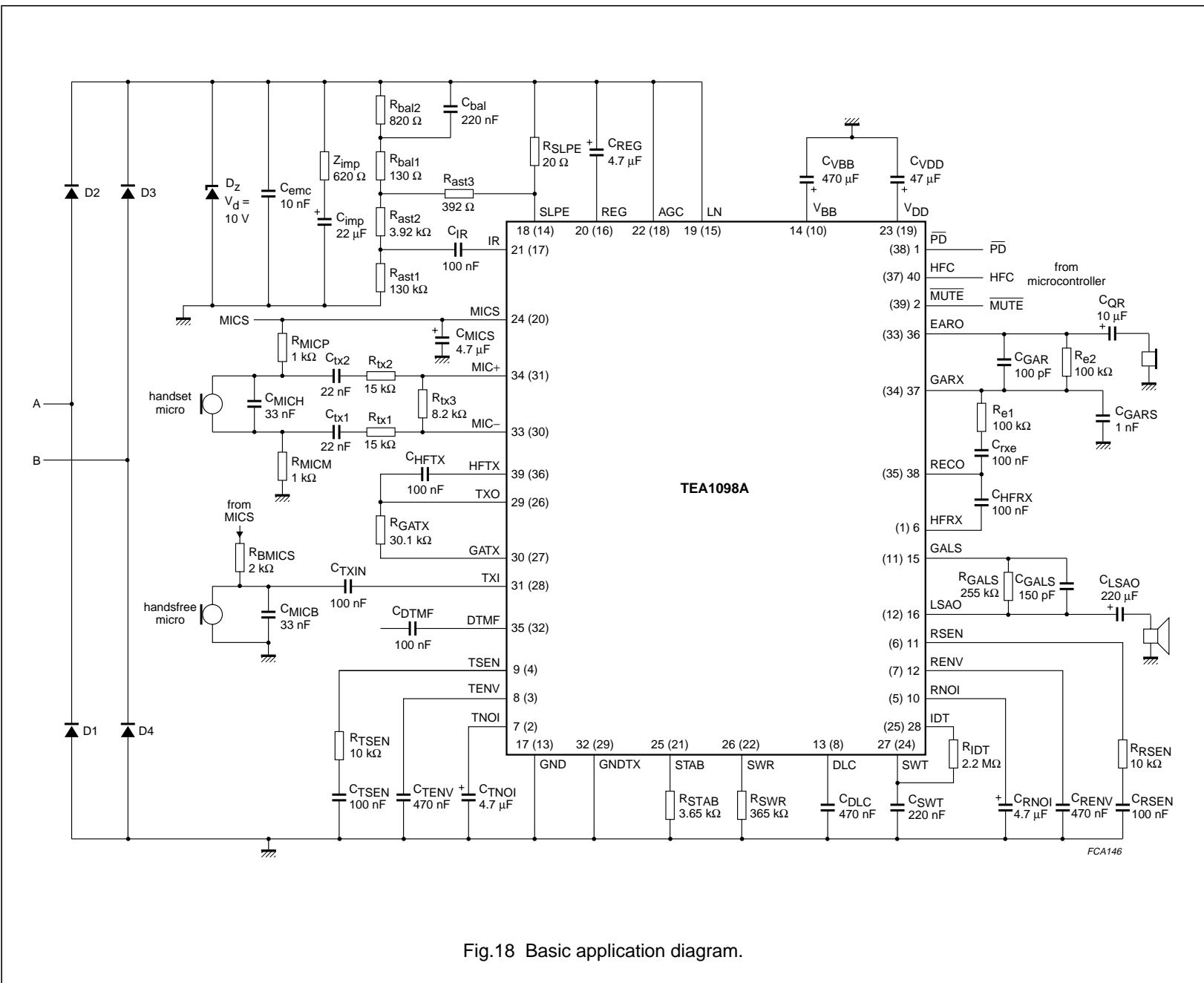

Fig.18 Basic application diagram.

FCA146

Speech and handsfree IC

TEA1098A

PACKAGE OUTLINES

VSO40: plastic very small outline package; 40 leads

SOT158-1

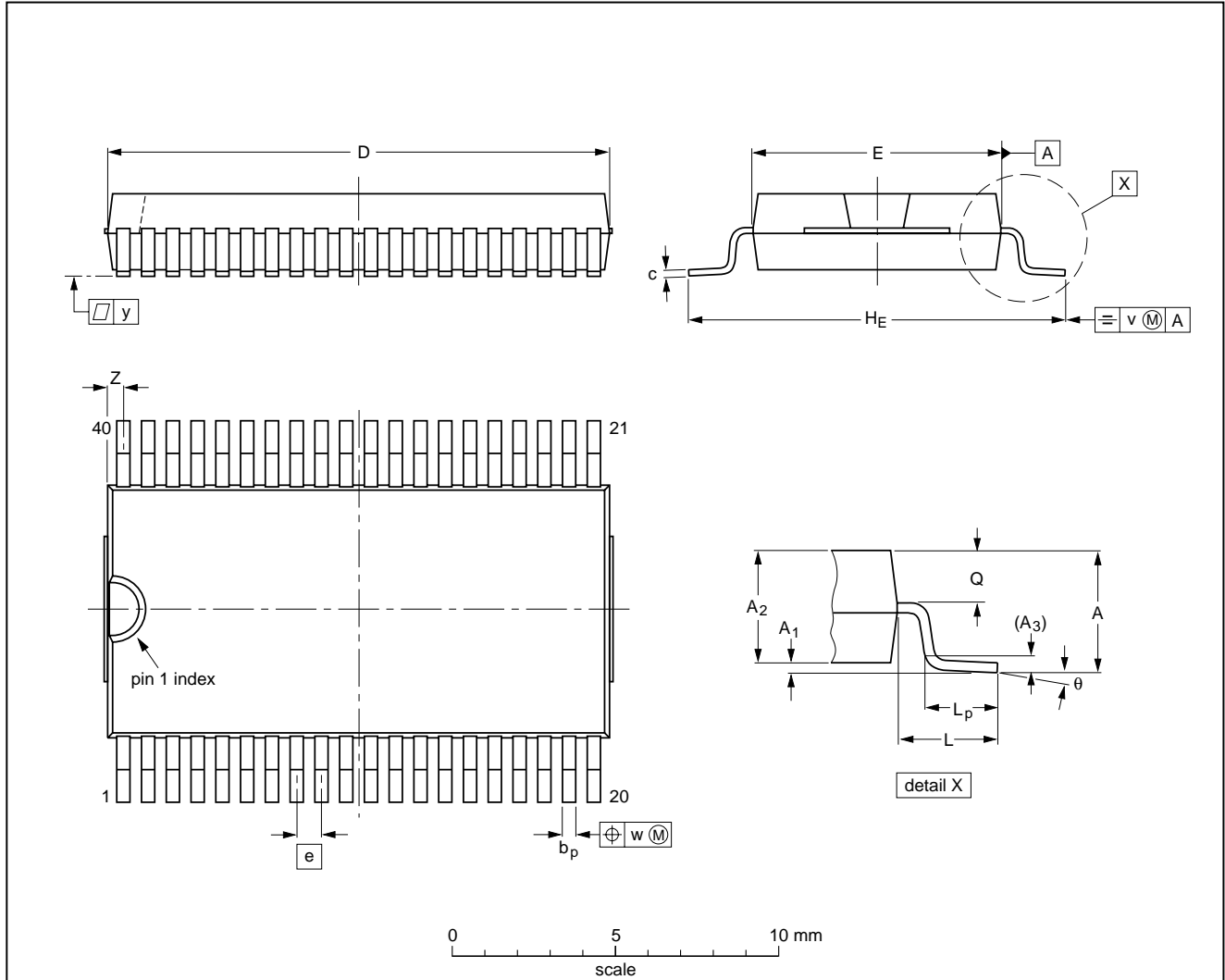

DIMENSIONS (inch dimensions are derived from the original mm dimensions)

UNIT	A max.	A ₁	A ₂	A ₃	b _p	c	D ⁽¹⁾	E ⁽²⁾	e	H _E	L	L _p	Q	v	w	y	Z ⁽¹⁾	θ
mm	2.70	0.3 0.1	2.45 2.25	0.25	0.42 0.30	0.22 0.14	15.6 15.2	7.6 7.5	0.762	12.3 11.8	2.25	1.7 1.5	1.15 1.05	0.2	0.1	0.1	0.6 0.3	7° 0°
inches	0.11	0.012 0.004	0.096 0.089	0.010	0.017 0.012	0.0087 0.0055	0.61 0.60	0.30 0.29	0.03	0.48 0.46	0.089	0.067 0.059	0.045 0.041	0.008	0.004	0.004	0.024 0.012	

Notes

1. Plastic or metal protrusions of 0.4 mm maximum per side are not included.
2. Plastic interlead protrusions of 0.25 mm maximum per side are not included.

OUTLINE VERSION	REFERENCES				EUROPEAN PROJECTION	ISSUE DATE
	IEC	JEDEC	EIAJ			
SOT158-1						92-11-17 95-01-24

Speech and handsfree IC

TEA1098A

QFP44: plastic quad flat package; 44 leads (lead length 1.3 mm); body 10 x 10 x 1.75 mm

SOT307-2

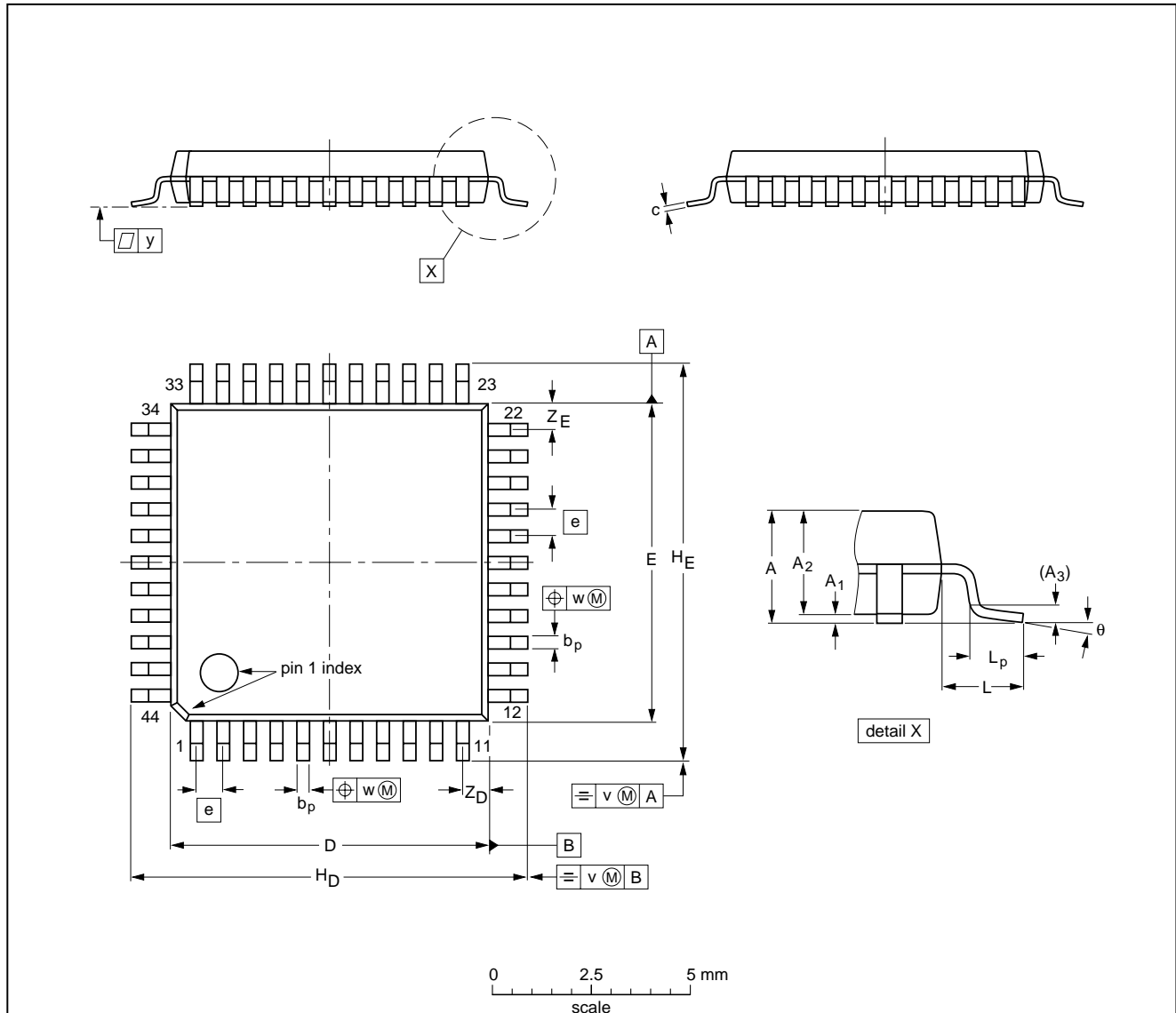

DIMENSIONS (mm are the original dimensions)

UNIT	A max.	A ₁	A ₂	A ₃	b _p	c	D ⁽¹⁾	E ⁽¹⁾	e	H _D	H _E	L	L _p	v	w	y	Z _D ⁽¹⁾	Z _E ⁽¹⁾	θ
mm	2.10	0.25 0.05	1.85 1.65	0.25	0.40 0.20	0.25 0.14	10.1 9.9	10.1 9.9	0.8	12.9 12.3	12.9 12.3	1.3	0.95 0.55	0.15	0.15	0.1	1.2 0.8	1.2 0.8	10° 0°

Note
1. Plastic or metal protrusions of 0.25 mm maximum per side are not included.

OUTLINE VERSION	REFERENCES				EUROPEAN PROJECTION	ISSUE DATE
	IEC	JEDEC	EIAJ			
SOT307-2						95-02-04 97-08-01

Speech and handsfree IC

TEA1098A

SOLDERING

Introduction

There is no soldering method that is ideal for all IC packages. Wave soldering is often preferred when through-hole and surface mounted components are mixed on one printed-circuit board. However, wave soldering is not always suitable for surface mounted ICs, or for printed-circuits with high population densities. In these situations reflow soldering is often used.

This text gives a very brief insight to a complex technology. A more in-depth account of soldering ICs can be found in our *"Data Handbook IC26; Integrated Circuit Packages"* (order code 9398 652 90011).

Reflow soldering

Reflow soldering techniques are suitable for all VSO packages.

Reflow soldering requires solder paste (a suspension of fine solder particles, flux and binding agent) to be applied to the printed-circuit board by screen printing, stencilling or pressure-syringe dispensing before package placement.

Several techniques exist for reflowing; for example, thermal conduction by heated belt. Dwell times vary between 50 and 300 seconds depending on heating method. Typical reflow temperatures range from 215 to 250 °C.

Preheating is necessary to dry the paste and evaporate the binding agent. Preheating duration: 45 minutes at 45 °C.

Wave soldering

Wave soldering techniques can be used for all VSO packages if the following conditions are observed:

- A double-wave (a turbulent wave with high upward pressure followed by a smooth laminar wave) soldering technique should be used.
- The longitudinal axis of the package footprint must be parallel to the solder flow.
- The package footprint must incorporate solder thieves at the downstream end.

During placement and before soldering, the package must be fixed with a droplet of adhesive. The adhesive can be applied by screen printing, pin transfer or syringe dispensing. The package can be soldered after the adhesive is cured.

Maximum permissible solder temperature is 260 °C, and maximum duration of package immersion in solder is 10 seconds, if cooled to less than 150 °C within 6 seconds. Typical dwell time is 4 seconds at 250 °C.

A mildly-activated flux will eliminate the need for removal of corrosive residues in most applications.

Repairing soldered joints

Fix the component by first soldering two diagonally-opposite end leads. Use only a low voltage soldering iron (less than 24 V) applied to the flat part of the lead. Contact time must be limited to 10 seconds at up to 300 °C. When using a dedicated tool, all other leads can be soldered in one operation within 2 to 5 seconds between 270 and 320 °C.

Speech and handsfree IC

TEA1098A

DEFINITIONS

Data sheet status	
Objective specification	This data sheet contains target or goal specifications for product development.
Preliminary specification	This data sheet contains preliminary data; supplementary data may be published later.
Product specification	This data sheet contains final product specifications.
Limiting values	
Limiting values given are in accordance with the Absolute Maximum Rating System (IEC 134). Stress above one or more of the limiting values may cause permanent damage to the device. These are stress ratings only and operation of the device at these or at any other conditions above those given in the Characteristics sections of the specification is not implied. Exposure to limiting values for extended periods may affect device reliability.	
Application information	
Where application information is given, it is advisory and does not form part of the specification.	

LIFE SUPPORT APPLICATIONS

These products are not designed for use in life support appliances, devices, or systems where malfunction of these products can reasonably be expected to result in personal injury. Philips customers using or selling these products for use in such applications do so at their own risk and agree to fully indemnify Philips for any damages resulting from such improper use or sale.

Speech and handsfree IC

TEA1098A

NOTES

Speech and handsfree IC

TEA1098A

NOTES

Speech and handsfree IC

TEA1098A

NOTES

Philips Semiconductors – a worldwide company

Argentina: see South America

Australia: 3 Figtree Drive, HOMEBUSH, NSW 2140,
Tel. +61 2 9704 8141, Fax. +61 2 9704 8139

Austria: Computerstr. 6, A-1101 WIEN, P.O. Box 213,
Tel. +43 1 60 101 1248, Fax. +43 1 60 101 1210

Belarus: Hotel Minsk Business Center, Bld. 3, r. 1211, Volodarski Str. 6,
220050 MINSK, Tel. +375 172 20 0733, Fax. +375 172 20 0773

Belgium: see The Netherlands

Brazil: see South America

Bulgaria: Philips Bulgaria Ltd., Energoproject, 15th floor,
51 James Bourchier Blvd., 1407 SOFIA,
Tel. +359 2 68 9211, Fax. +359 2 68 9102

Canada: PHILIPS SEMICONDUCTORS/COMPONENTS,
Tel. +1 800 234 7381, Fax. +1 800 943 0087

China/Hong Kong: 501 Hong Kong Industrial Technology Centre,
72 Tat Chee Avenue, Kowloon Tong, HONG KONG,
Tel. +852 2319 7888, Fax. +852 2319 7700

Colombia: see South America

Czech Republic: see Austria

Denmark: Sydhavnsgade 23, 1780 COPENHAGEN V,
Tel. +45 33 29 3333, Fax. +45 33 29 3905

Finland: Sinikalliontie 3, FIN-02630 ESPOO,
Tel. +358 9 615 800, Fax. +358 9 6158 0920

France: 51 Rue Carnot, BP317, 92156 SURESNES Cedex,
Tel. +33 1 4099 6161, Fax. +33 1 4099 6427

Germany: Hammerbrookstraße 69, D-20097 HAMBURG,
Tel. +49 40 2353 60, Fax. +49 40 2353 6300

Hungary: see Austria

India: Philips INDIA Ltd, Band Box Building, 2nd floor,
254-D, Dr. Annie Besant Road, Worli, MUMBAI 400 025,
Tel. +91 22 493 8541, Fax. +91 22 493 0966

Indonesia: PT Philips Development Corporation, Semiconductors Division,
Gedung Philips, Jl. Buncit Raya Kav.99-100, JAKARTA 12510,
Tel. +62 21 794 0040 ext. 2501, Fax. +62 21 794 0080

Ireland: Newstead, Clonskeagh, DUBLIN 14,
Tel. +353 1 7640 000, Fax. +353 1 7640 200

Israel: RAPAC Electronics, 7 Kehilat Saloniki St, PO Box 18053,
TEL AVIV 61180, Tel. +972 3 645 0444, Fax. +972 3 649 1007

Italy: PHILIPS SEMICONDUCTORS, Via Casati, 23 - 20052 MONZA (MI),
Tel. +39 039 203 6838, Fax +39 039 203 6800

Japan: Philips Bldg 13-37, Kohnan 2-chome, Minato-ku,
TOKYO 108-8507, Tel. +81 3 3740 5130, Fax. +81 3 3740 5057

Korea: Philips House, 260-199 Itaewon-dong, Yongsan-ku, SEOUL,
Tel. +82 2 709 1412, Fax. +82 2 709 1415

Malaysia: No. 76 Jalan Universiti, 46200 PETALING JAYA, SELANGOR,
Tel. +60 3 750 5214, Fax. +60 3 757 4880

Mexico: 5900 Gateway East, Suite 200, EL PASO, TEXAS 79905,
Tel. +9-5 800 234 7381, Fax +9-5 800 943 0087

Middle East: see Italy

Netherlands: Postbus 90050, 5600 PB EINDHOVEN, Bldg. VB,
Tel. +31 40 27 82785, Fax. +31 40 27 88399

New Zealand: 2 Wagener Place, C.P.O. Box 1041, AUCKLAND,
Tel. +64 9 849 4160, Fax. +64 9 849 7811

Norway: Box 1, Manglerud 0612, OSLO,
Tel. +47 22 74 8000, Fax. +47 22 74 8341

Pakistan: see Singapore

Philippines: Philips Semiconductors Philippines Inc.,
106 Valero St. Salcedo Village, P.O. Box 2108 MCC, MAKATI,
Metro MANILA, Tel. +63 2 816 6380, Fax. +63 2 817 3474

Poland: Al.Jerozolimskie 195 B, 02-222 WARSAW,
Tel. +48 22 5710 000, Fax. +48 22 5710 001

Portugal: see Spain

Romania: see Italy

Russia: Philips Russia, Ul. Usatcheva 35A, 119048 MOSCOW,
Tel. +7 095 755 6918, Fax. +7 095 755 6919

Singapore: Lorong 1, Toa Payoh, SINGAPORE 319762,
Tel. +65 350 2538, Fax. +65 251 6500

Slovakia: see Austria

Slovenia: see Italy

South Africa: S.A. PHILIPS Pty Ltd., 195-215 Main Road Martindale,
2092 JOHANNESBURG, P.O. Box 58088 Newville 2114,
Tel. +27 11 471 5401, Fax. +27 11 471 5398

South America: Al. Vicente Pinzon, 173, 6th floor,
04547-130 SÃO PAULO, SP, Brazil,
Tel. +55 11 821 2333, Fax. +55 11 821 2382

Spain: Balmes 22, 08007 BARCELONA,
Tel. +34 93 301 6312, Fax. +34 93 301 4107

Sweden: Kottbygatan 7, Akalla, S-16485 STOCKHOLM,
Tel. +46 8 5985 2000, Fax. +46 8 5985 2745

Switzerland: Allmendstrasse 140, CH-8027 ZÜRICH,
Tel. +41 1 488 2741 Fax. +41 1 488 3263

Taiwan: Philips Semiconductors, 6F, No. 96, Chien Kuo N. Rd., Sec. 1,
TAIPEI, Taiwan Tel. +886 2 2134 2886, Fax. +886 2 2134 2874

Thailand: PHILIPS ELECTRONICS (THAILAND) Ltd.,
209/2 Sanpavuth-Bangna Road Prakanong, BANGKOK 10260,
Tel. +66 2 745 4090, Fax. +66 2 398 0793

Turkey: Yukari Dudullu, Org. San. Blg., 2.Cad. Nr. 28 81260 Umraniye,
ISTANBUL, Tel. +90 216 522 1500, Fax. +90 216 522 1813

Ukraine: PHILIPS UKRAINE, 4 Patrice Lumumba str., Building B, Floor 7,
252042 KIEV, Tel. +380 44 264 2776, Fax. +380 44 268 0461

United Kingdom: Philips Semiconductors Ltd., 276 Bath Road, Hayes,
MIDDLESEX UB3 5BX, Tel. +44 208 730 5000, Fax. +44 208 754 8421

United States: 811 East Arques Avenue, SUNNYVALE, CA 94088-3409,
Tel. +1 800 234 7381, Fax. +1 800 943 0087

Uruguay: see South America

Vietnam: see Singapore

Yugoslavia: PHILIPS, Trg N. Pasica 5/v, 11000 BEOGRAD,
Tel. +381 11 3341 299, Fax.+381 11 3342 553

For all other countries apply to: Philips Semiconductors,
International Marketing & Sales Communications, Building BE-p, P.O. Box 218,
5600 MD EINDHOVEN, The Netherlands, Fax. +31 40 27 24825

Internet: <http://www.semiconductors.philips.com>

© Philips Electronics N.V. 2000

SCA 69

All rights are reserved. Reproduction in whole or in part is prohibited without the prior written consent of the copyright owner.

The information presented in this document does not form part of any quotation or contract, is believed to be accurate and reliable and may be changed without notice. No liability will be accepted by the publisher for any consequence of its use. Publication thereof does not convey nor imply any license under patent- or other industrial or intellectual property rights.

Printed in The Netherlands

403502/01/pp40

Date of release: 2000 Mar 21

Document order number: 9397 750 06808

Let's make things better.

Philips
Semiconductors



PHILIPS