

DATA SHEET

TDA8920

2 × 50 W class-D power amplifier

Preliminary specification
File under Integrated Circuits, IC01

1998 Dec 01

2 × 50 W class-D power amplifier**TDA8920****FEATURES**

- High efficiency (90%)
- Operating voltage from ± 15 V to ± 30 V
- Very low quiescent current
- Low distortion
- Fixed gain of 30 dB
- High output power
- Output power limiter
- Good ripple rejection
- Usable as a mono amplifier in Bridge-Tied Load (BTL) or as a stereo Single-Ended (SE) amplifier
- Tracking possibility for oscillator frequency
- Differential audio inputs
- No switch-on or switch-off plops
- Short-circuit proof across the load
- Electrostatic discharge protection on all pins
- Thermally protected.

APPLICATIONS

- Television sets
- Home-sound systems
- Multimedia systems.

GENERAL DESCRIPTION

The TDA8920 is a high efficiency class-D audio power amplifier. It can be used in a mono Bridge-Tied Load (BTL) or in a stereo Single-Ended (SE) configuration. The device operates over a wide supply voltage range from ± 15 V up to ± 30 V and consumes a very low quiescent current.

QUICK REFERENCE DATA

SYMBOL	PARAMETER	CONDITIONS	MIN.	TYP.	MAX.	UNIT
General						
V_{DD}	operating supply voltage		± 15	± 25	± 30	V
$I_{q(\text{tot})}$	total quiescent current		–	50	60	mA
η	efficiency	$P_o = 10$ W	85	90	–	%
Stereo single-ended configuration						
P_o	output power	THD = 10%	tof	35	–	W
$G_{V(\text{cl})}$	closed loop voltage gain		29	30	31	dB
$ Z_i $	input impedance		80	120	–	k Ω
$V_{n(o)}$	noise output voltage		–	100	–	μ V
SVRR	supply voltage ripple rejection		60	–	–	dB
α_{cs}	channel separation		50	tof	–	dB
Mono bridge-tied load configuration						
P_o	output power	THD = 10%	–	130	–	W
$G_{V(\text{cl})}$	closed loop voltage gain		35	36	37	dB
$ Z_i $	input impedance		40	60	–	k Ω
$V_{n(o)}$	noise output voltage		–	140	–	μ V
SVRR	supply voltage ripple rejection		66	–	–	dB
$ \Delta V_O $	DC output offset voltage		–	–	50	mV

$2 \times 50 \text{ W}$ class-D power amplifier

TDA8920

PINNING

SYMBOL	PIN	DESCRIPTION
OSC	1	oscillator frequency adjustment
SGND	2	signal ground (0 V)
IN1-	3	negative input channel 1
IN1+	4	positive input channel 1
V _{DD1}	5	positive supply voltage 1
BOOT1	6	bootstrapping capacitor 1
OUT1	7	output 1
V _{SS1}	8	negative supply voltage 1; note 1
STAB	9	internal stabilizer decoupling
V _{SS2}	10	negative supply voltage 2; note 1
OUT2	11	output 2
BOOT2	12	bootstrapping capacitor 2
V _{DD2}	13	positive supply voltage 2
IN2+	14	positive input channel 2
IN2-	15	negative input channel 2
LIM	16	current limiting adjustment
MODE	17	mode select input

Note

1. The case of the package is connected to pins 8 and 10 (V_{SS1} and V_{SS2}). Therefore no other voltage than V_{SS} should be connected to the case or the heatsink.

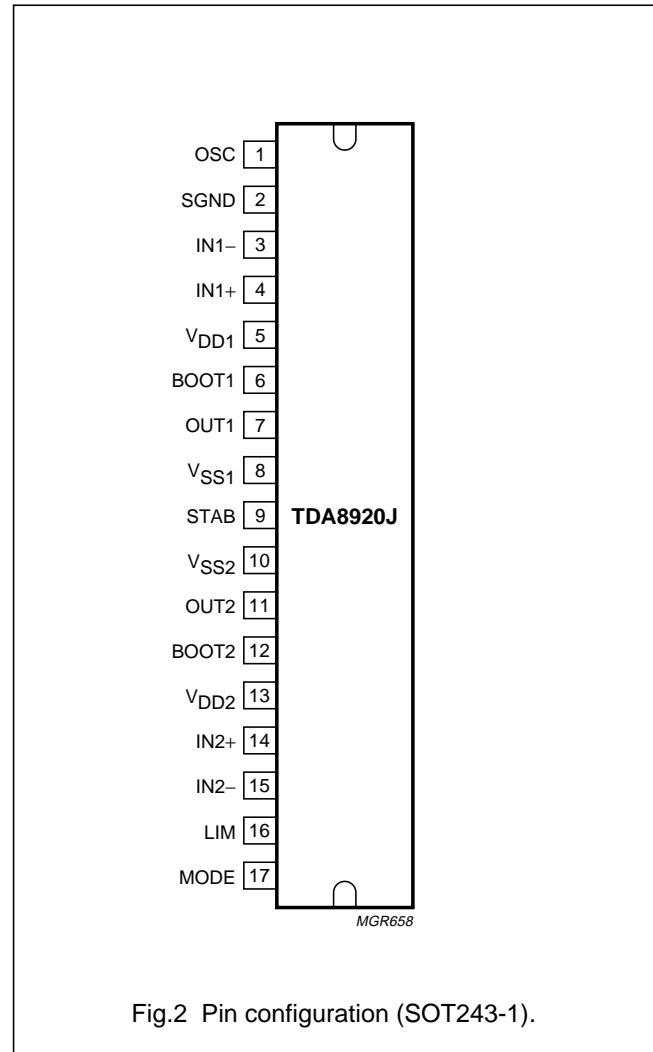

2 × 50 W class-D power amplifier

TDA8920

FUNCTIONAL DESCRIPTION

The TDA8920 is a multi purpose audio power amplifier in class-D technology. It contains two independent amplifiers with high output power, high efficiency (90%), low distortion and a low quiescent current. The amplifiers can be connected in the following configurations:

- Mono bridge-tied load amplifier
- Stereo single-ended amplifiers.

The amplifier can be switched in three operating modes with the mode select input:

- Standby mode, with a very low supply current (practically zero)
- Mute mode; the amplifiers are operational but the audio signal at the output is suppressed
- Operating mode (amplifier fully operational) with output signal.

For suppressing plop noise the amplifier will remain automatically for approximately 500 ms in the mute mode before switching to operating mode. During this time the coupling capacitors at the input are fully charged. An example of a switching circuit for driving the mode select input is illustrated in Fig.3.

Pulse Width Modulation (PWM) frequency

The output signal of the amplifier is a PWM signal with a sample frequency of 500 kHz. The use of a second order LC filter in the application results in an analog audio signal across the loudspeaker. This switching frequency is fixed by an external resistor R_{OSC} connected between pin OSC and pin SGND. With the resistor value given in the application diagram, the oscillating frequency is typical 500 kHz. The oscillator frequency can be calculated using:

$$f_{osc} = \frac{5 \cdot 10^9}{R_{OSC}} \text{ [Hz]}$$

If two or more devices are used in the same audio system it is advised to have both devices working on the same oscillation frequency. This can be realized by connecting all OSC pins together.

Current limiting

With an external resistor R_{LIM} connected between pin LIM and V_{SS} the maximum output current of the amplifiers can be set. If pin LIM is short-circuited to V_{SS} , then the maximum output current is limited to 7 A. The relationship between maximum output current and resistor value is given by:

$$I_{O(max)} = \frac{70 \cdot 10^3}{(10 \cdot 10^3 + R_{LIM})} \text{ [A]}$$

Protections

Protections are included to avoid the device being damaged at:

- Over-temperature $T_j > 150 \text{ }^\circ\text{C}$
- Short-circuit of the loudspeaker terminals: when short-circuited the power dissipation is limited
- A maximum current limiter which limits the maximum output current to 7 A, or to the value set by R_{LIM} . During limiting the current is measured and when the current is higher than 7 A, the amplifier is switched off within 3 μs and every 20 ms the IC tries to restart. The dissipation will be low because of this low duty cycle.
- ESD protection (human body model: 3000 V and machine model: 300 V).

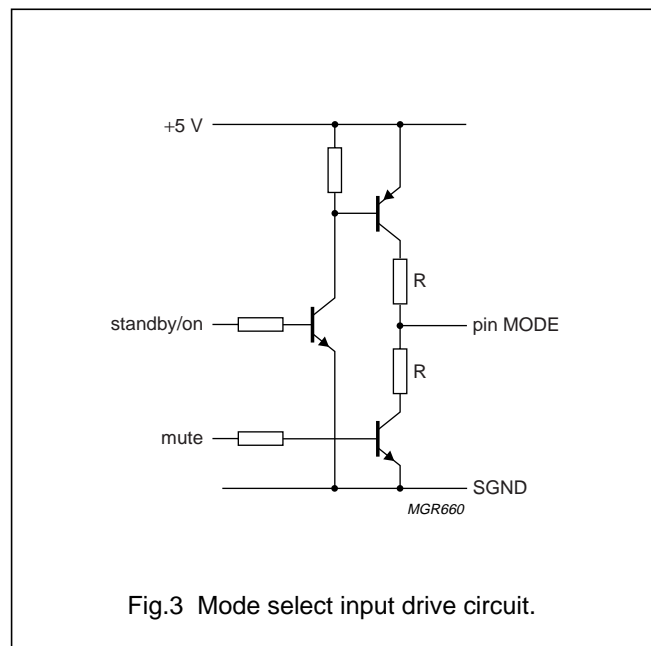

Fig.3 Mode select input drive circuit.

2 × 50 W class-D power amplifier**TDA8920****LIMITING VALUES**

In accordance with the Absolute Maximum Rating System (IEC 134).

SYMBOL	PARAMETER	CONDITIONS	MIN.	MAX.	UNIT
V _{DD}	supply voltage		–	±30	V
V _{ms}	mode select switch voltage	with respect to SGND	–	5.5	V
V _{sc}	short-circuit voltage of output pins		–	±30	V
I _{OSM}	non-repetitive peak output current		–	10	A
I _{ORM}	repetitive peak output current		–	7.5	A
P _{tot}	total power dissipation		–	60	W
T _{stg}	storage temperature		–55	+150	°C
T _{amb}	operating ambient temperature		–40	+85	°C
T _{vj}	virtual junction temperature		–	150	°C

THERMAL CHARACTERISTICS

SYMBOL	PARAMETER	CONDITIONS	VALUE	UNIT
R _{th(j-a)}	thermal resistance from junction to ambient	in free air	40	K/W
R _{th(j-c)}	thermal resistance from junction to case		10	K/W

QUALITY SPECIFICATION

Quality according to "SNW-FQ-611-part E", if this type is used as an audio amplifier.

SWITCHING CHARACTERISTICSV_{DD} = ±25 V; T_{amb} = 25 °C; measured in Fig.5; unless otherwise specified.

SYMBOL	PARAMETER	MIN.	TYP.	MAX.	UNIT
f _{osc}	oscillator frequency	400	500	600	kHz
V _{OSC(p-p)}	voltage at tracking point (peak-to-peak value)	–	1.75	–	V

2 × 50 W class-D power amplifier

TDA8920

DC CHARACTERISTICS

$V_{DD} = \pm 25\text{ V}$; $T_{amb} = 25\text{ }^\circ\text{C}$; measured in Fig.5; unless otherwise specified.

SYMBOL	PARAMETER	CONDITIONS	MIN.	TYP.	MAX.	UNIT
Supplies						
V_{DD}	supply voltage range	note 1	± 15	± 25	± 30	V
$I_{q(\text{tot})}$	total quiescent current		–	50	60	mA
I_{stb}	standby current		–	0.2	50	μA
Amplifier outputs						
$ V_{OO} $	output offset voltage	on and mute	–	–	50	mV
$ \Delta V_{OO} $	delta output offset voltage	on \leftrightarrow mute	–	–	30	mV
Mode select input; see Fig.4						
V_{ms}	input voltage range	note 2	0	–	5.5	V
I_{ms}	input current	$V_{\text{ms}} = 5.5\text{ V}$	–	–	tbf	μA
$V_{\text{th}1+}$	threshold voltage	standby \rightarrow mute; note 2	–	–	2	V
$V_{\text{th}1-}$	threshold voltage	mute \rightarrow standby; note 2	1	–	–	V
$V_{\text{ms}(\text{hys}1)}$	hysteresis $ (V_{\text{th}1+}) - (V_{\text{th}1-}) $		–	200	–	mV
$V_{\text{th}2+}$	threshold voltage	mute \rightarrow on; note 2	–	–	4	V
$V_{\text{th}2-}$	threshold voltage	on \rightarrow mute; note 2	3	–	–	V
$V_{\text{ms}(\text{hys}2)}$	hysteresis $ (V_{\text{th}2+}) - (V_{\text{th}2-}) $		–	200	–	mV

Notes

1. The circuit is DC adjusted at $V_{DD} = \pm 15\text{ V}$ to $\pm 30\text{ V}$.
2. Referenced to SGND (0 V).

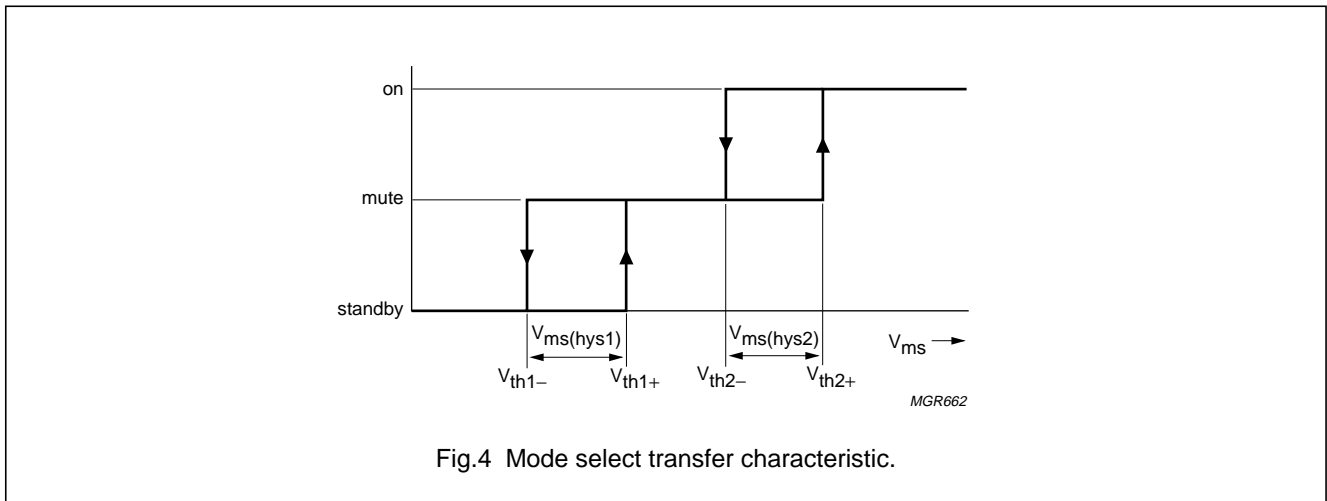

Fig.4 Mode select transfer characteristic.

2 × 50 W class-D power amplifier**TDA8920****AC CHARACTERISTICS****Stereo single-ended application**

$V_{DD} = \pm 25\text{ V}$; $R_L = 8\ \Omega$; $f_i = 1\text{ kHz}$; $T_{amb} = 25\text{ }^\circ\text{C}$; measured in Fig.5; unless otherwise specified.

SYMBOL	PARAMETER	CONDITIONS	MIN.	TYP.	MAX.	UNIT
P_o	output power	THD = 0.5%	tbf	30	–	W
		THD = 10%	tbf	35	–	W
		THD = 0.5%; $V_p = \pm 30\text{ V}$	–	40	–	W
		THD = 10%; $V_p = \pm 30\text{ V}$	–	50	–	W
THD	total harmonic distortion	$P_o = 1\text{ W}$; note 1				
		$f_i = 1\text{ kHz}$	–	0.1	0.15	%
		$f_i = 10\text{ kHz}$	–	0.2	–	%
$G_{V(cl)}$	closed loop voltage gain		29	30	31	dB
η	efficiency	$P_o = \text{tbf W}$; $f_i = 1\text{ kHz}$; note 2	85	90	–	%
SVRR	supply voltage ripple rejection	on; note 3	–	60	–	dB
		on; note 4	tbf	tbf	–	dB
		mute; note 3	–	60	–	dB
		standby; note 3	–	80	–	dB
$ Z_i $	input impedance		80	120		k Ω
$V_{n(o)}$	noise output voltage	on; note 5	–	100	200	μV
		on; note 6	–	tbf	–	μV
		mute; note 7	–	100	–	μV
α_{cs}	channel separation	note 8	50	tbf	–	dB
$ \Delta G_v $	channel unbalance		–	–	1	dB
V_o	output signal	mute; note 9	–	–	500	μV
CMRR	common mode rejection ratio	$V_{i(CM)(rms)} = 1\text{ V}$	–	65	–	dB

Notes

- Total harmonic distortion is measured in a bandwidth of 22 Hz to 22 kHz, using an 11th-order low-pass filter. When distortion is measured using a lower order low-pass filter a significantly higher value will be found, due to the switching frequency outside the audio band.
- Output power measured across the loudspeaker load.
- $V_{ripple} = V_{ripple(max)} = 2\text{ V (p-p)}$; $f_i = 100\text{ Hz}$; $R_s = 0\ \Omega$.
- $V_{ripple} = V_{ripple(max)} = 2\text{ V (p-p)}$; $f_i = 1\text{ kHz}$; $R_s = 0\ \Omega$.
- $B = 22\text{ Hz to } 22\text{ kHz}$; $R_s = 0\ \Omega$.
- $B = 22\text{ Hz to } 22\text{ kHz}$; $R_s = 10\text{ k}\Omega$.
- $B = 22\text{ Hz to } 22\text{ kHz}$; independent of R_s .
- $P_o = \text{tbf W}$; $R_s = 0\ \Omega$.
- $V_i = V_{i(max)} = 1\text{ V (RMS)}$.

2 × 50 W class-D power amplifier**TDA8920****Mono bridge-tied load application** $V_{DD} = \pm 25\text{ V}$; $R_L = 8\ \Omega$; $f_i = 1\text{ kHz}$; $T_{amb} = 25\text{ }^\circ\text{C}$; measured in Fig.6; unless otherwise specified.

SYMBOL	PARAMETER	CONDITIONS	MIN.	TYP.	MAX.	UNIT
P_o	output power	THD = 0.5%	tbf	100	–	W
		THD = 10%	tbf	130	–	W
		THD = 0.5%; $V_p = \pm 30\text{ V}$	–	150	–	W
		THD = 10%; $V_p = \pm 30\text{ V}$	–	190	–	W
THD	total harmonic distortion	$P_o = 1\text{ W}$; note 1				
		$f_i = 1\text{ kHz}$	–	0.1	0.15	%
		$f_i = 10\text{ kHz}$	–	0.2	–	%
$G_{V(cl)}$	closed loop voltage gain		35	36	37	dB
η	efficiency	$P_o = \text{tbf W}$; $f_i = 1\text{ kHz}$; note 2	tbf	tbf	–	%
SVRR	supply voltage ripple rejection	on; note 3	–	66	–	dB
		on; note 4	tbf	–	–	dB
		mute; note 3	–	66	–	dB
		standby; note 3	80	–	–	dB
$ Z_i $	input impedance		40	60	–	$k\Omega$
$V_{n(o)}$	noise output voltage	on; note 5	–	140	280	μV
		on; note 6	–	tbf	–	μV
		mute; note 7	–	140	–	μV
V_o	output signal	mute; note 8	–	–	tbf	mV
CMRR	common mode rejection ratio	$V_{i(CM)(rms)} = 1\text{ V}$	–	65	–	dB

Notes

- Total harmonic distortion is measured in a bandwidth of 22 Hz to 22 kHz, using an 11th-order low-pass filter. When distortion is measured using a lower order low-pass filter a significantly higher value will be found, due to the switching frequency outside the audio band.
- Output power measured across the loudspeaker load.
- $V_{ripple} = V_{ripple(max)} = 2\text{ V (p-p)}$; $f_i = 100\text{ Hz}$; $R_s = 0\ \Omega$.
- $V_{ripple} = V_{ripple(max)} = 2\text{ V (p-p)}$; $f_i = 1\text{ kHz}$; $R_s = 0\ \Omega$.
- $B = 22\text{ Hz to } 22\text{ kHz}$; $R_s = 0\ \Omega$.
- $B = 22\text{ Hz to } 22\text{ kHz}$; $R_s = 10\text{ k}\Omega$.
- $B = 22\text{ Hz to } 22\text{ kHz}$; independent of R_s .
- $V_i = V_{i(max)} = 1\text{ V (RMS)}$.

2 × 50 W class-D power amplifier

TDA8920

APPLICATION AND TEST INFORMATION

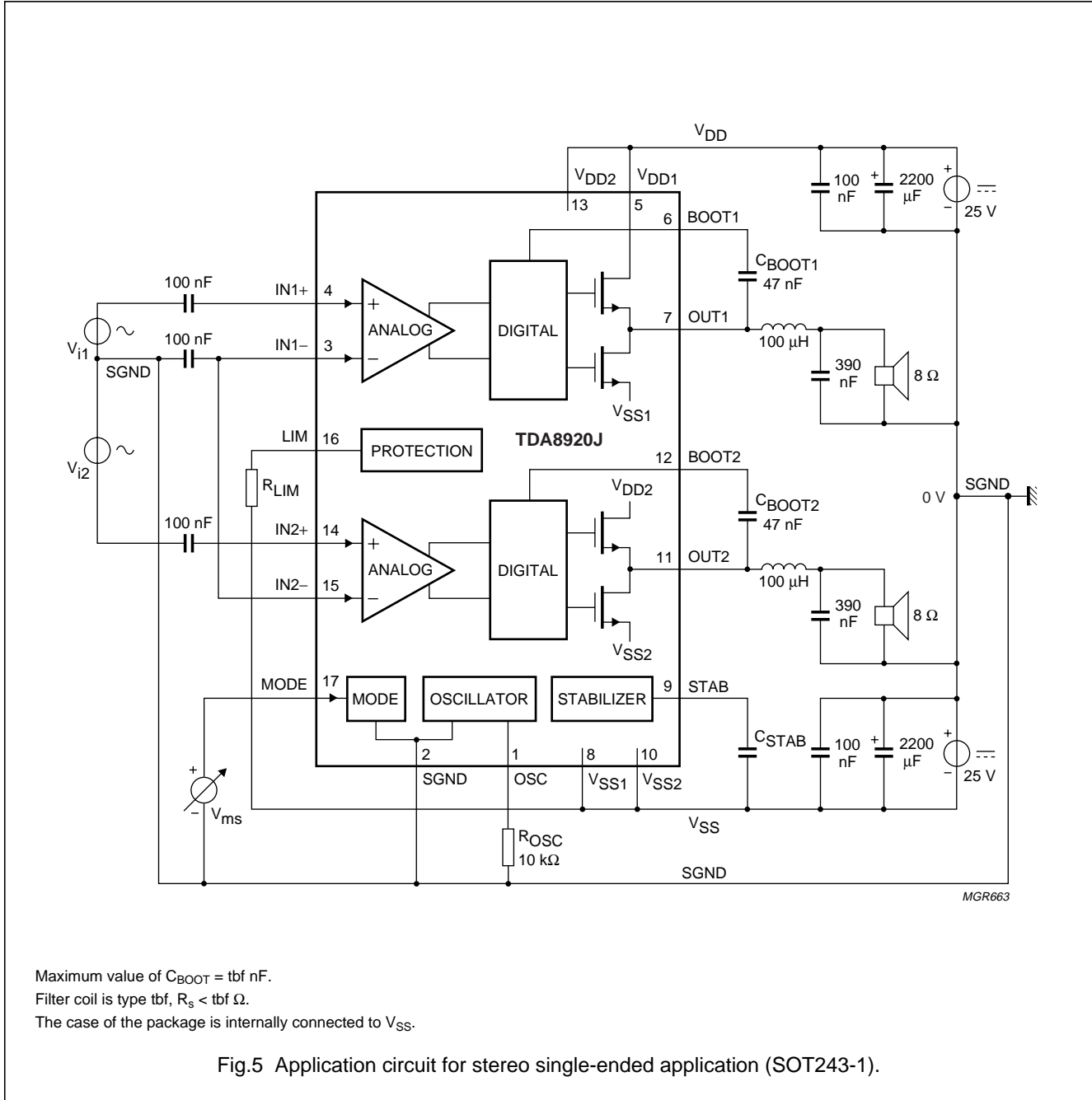

2 × 50 W class-D power amplifier

TDA8920

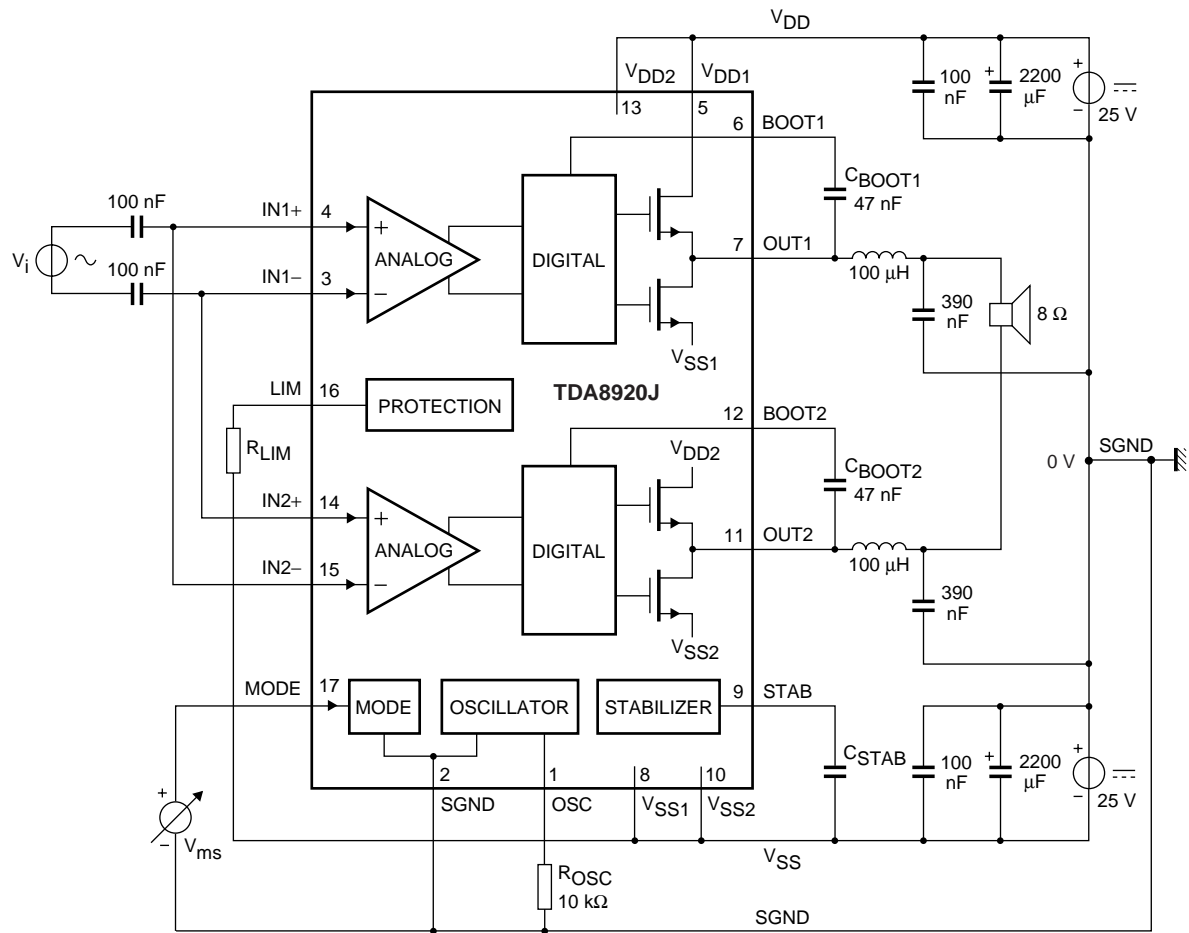

MGR664

Maximum value of $C_{BOOT} = tbf \text{ nF}$.
 Filter coil is type tbf , $R_s < tbf \Omega$.
 The case of the package is internally connected to V_{SS} .

Fig.6 Application circuit for mono bridge-tied load application (SOT243-1).

2 × 50 W class-D power amplifier

TDA8920

PACKAGE OUTLINES

DBS17P: plastic DIL-bent-SIL power package; 17 leads (lead length 12 mm)

SOT243-1

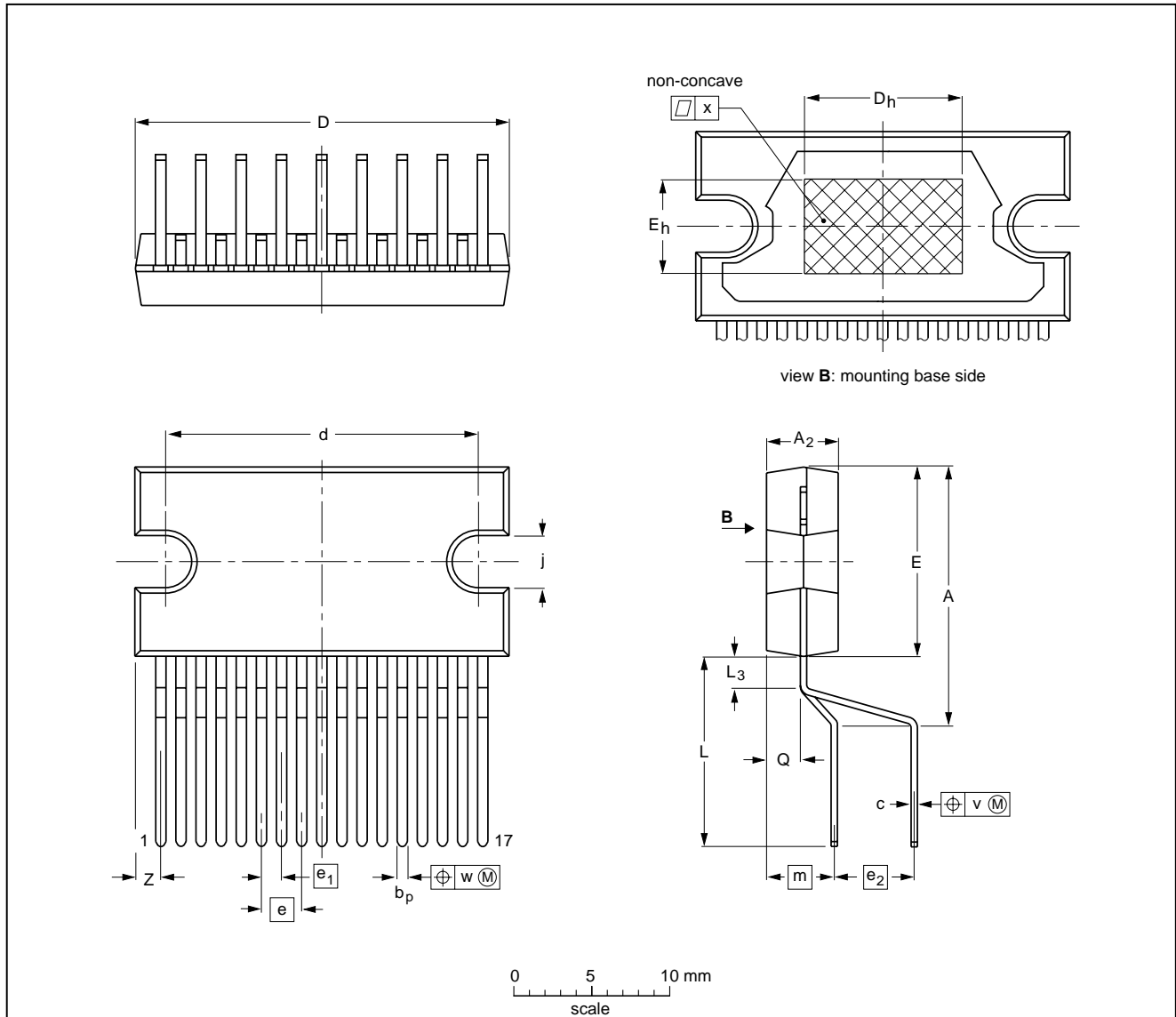

DIMENSIONS (mm are the original dimensions)

UNIT	A	A ₂	b _p	c	D ⁽¹⁾	d	D _h	E ⁽¹⁾	e	e ₁	e ₂	E _h	j	L	L ₃	m	Q	v	w	x	Z ⁽¹⁾
mm	17.0 15.5	4.6 4.2	0.75 0.60	0.48 0.38	24.0 23.6	20.0 19.6	10	12.2 11.8	2.54	1.27	5.08	6	3.4 3.1	12.4 11.0	2.4 1.6	4.3	2.1 1.8	0.8	0.4	0.03	2.00 1.45

Note

1. Plastic or metal protrusions of 0.25 mm maximum per side are not included.

OUTLINE VERSION	REFERENCES				EUROPEAN PROJECTION	ISSUE DATE
	IEC	JEDEC	EIAJ			
SOT243-1						95-03-11 97-12-16

2 × 50 W class-D power amplifier

TDA8920

HSOP20: heatsink small outline package; 20 leads

SOT418-1

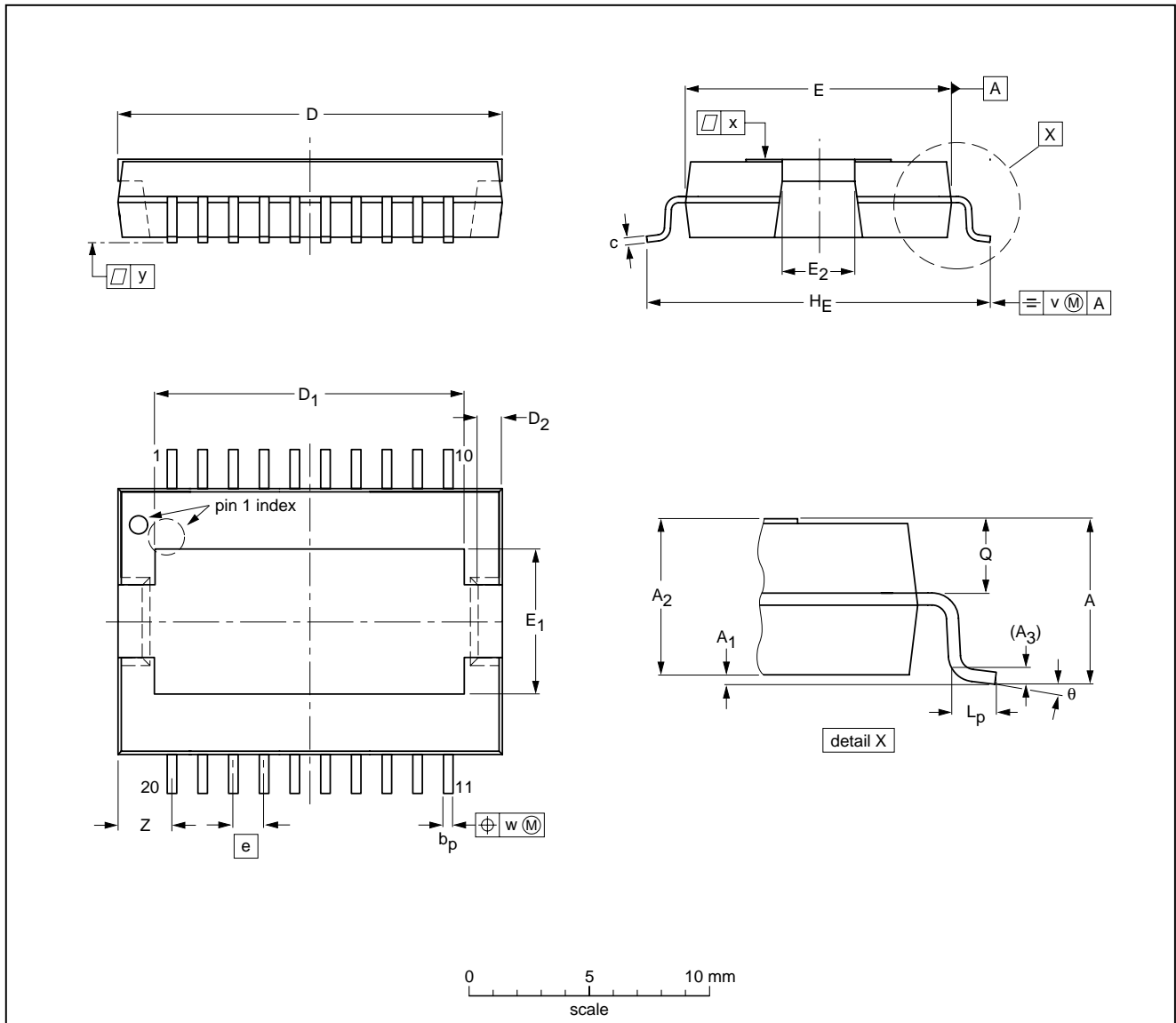

DIMENSIONS (mm are the original dimensions)

UNIT	A _{max.}	A ₁	A ₂	A ₃	b _p	c	D ⁽¹⁾	D ₁	D ₂	E ⁽¹⁾	E ₁	E ₂	e	H _E	L _p	Q	v	w	x	y	Z	θ
mm	3.7	0.3 0.1	3.5 3.2	0.35	0.53 0.40	0.32 0.23	16.0 15.8	13.0 12.6	1.1 0.9	11.1 10.9	6.2 5.8	2.9 2.5	1.27	14.5 13.9	1.1 0.8	1.7 1.5	0.25	0.25	0.03	0.1	2.5 2.0	8° 0°

Note

1. Plastic or metal protrusions of 0.25 mm maximum per side are not included.

OUTLINE VERSION	REFERENCES				EUROPEAN PROJECTION	ISSUE DATE
	IEC	JEDEC	EIAJ			
SOT418-1						97-11-03 98-02-25

2 × 50 W class-D power amplifier

TDA8920

SOLDERING

Introduction

This text gives a very brief insight to a complex technology. A more in-depth account of soldering ICs can be found in our "Data Handbook IC26; Integrated Circuit Packages" (document order number 9398 652 90011).

There is no soldering method that is ideal for all IC packages. Wave soldering is often preferred when through-hole and surface mount components are mixed on one printed-circuit board. However, wave soldering is not always suitable for surface mount ICs, or for printed-circuit boards with high population densities. In these situations reflow soldering is often used.

Through-hole mount packages

SOLDERING BY DIPPING OR BY SOLDER WAVE

The maximum permissible temperature of the solder is 260 °C; solder at this temperature must not be in contact with the joints for more than 5 seconds. The total contact time of successive solder waves must not exceed 5 seconds.

The device may be mounted up to the seating plane, but the temperature of the plastic body must not exceed the specified maximum storage temperature ($T_{stg(max)}$). If the printed-circuit board has been pre-heated, forced cooling may be necessary immediately after soldering to keep the temperature within the permissible limit.

MANUAL SOLDERING

Apply the soldering iron (24 V or less) to the lead(s) of the package, either below the seating plane or not more than 2 mm above it. If the temperature of the soldering iron bit is less than 300 °C it may remain in contact for up to 10 seconds. If the bit temperature is between 300 and 400 °C, contact may be up to 5 seconds.

Surface mount packages

REFLOW SOLDERING

Reflow soldering requires solder paste (a suspension of fine solder particles, flux and binding agent) to be applied to the printed-circuit board by screen printing, stencilling or pressure-syringe dispensing before package placement.

Several methods exist for reflowing; for example, infrared/convection heating in a conveyor type oven. Throughput times (preheating, soldering and cooling) vary between 100 and 200 seconds depending on heating method.

Typical reflow peak temperatures range from 215 to 250 °C. The top-surface temperature of the packages should preferably be kept below 230 °C.

WAVE SOLDERING

Conventional single wave soldering is not recommended for surface mount devices (SMDs) or printed-circuit boards with a high component density, as solder bridging and non-wetting can present major problems.

To overcome these problems the double-wave soldering method was specifically developed.

If wave soldering is used the following conditions must be observed for optimal results:

- Use a double-wave soldering method comprising a turbulent wave with high upward pressure followed by a smooth laminar wave.
- For packages with leads on two sides and a pitch (e):
 - larger than or equal to 1.27 mm, the footprint longitudinal axis is **preferred** to be parallel to the transport direction of the printed-circuit board;
 - smaller than 1.27 mm, the footprint longitudinal axis **must** be parallel to the transport direction of the printed-circuit board.

The footprint must incorporate solder thieves at the downstream end.

- For packages with leads on four sides, the footprint must be placed at a 45° angle to the transport direction of the printed-circuit board. The footprint must incorporate solder thieves downstream and at the side corners.

During placement and before soldering, the package must be fixed with a droplet of adhesive. The adhesive can be applied by screen printing, pin transfer or syringe dispensing. The package can be soldered after the adhesive is cured.

Typical dwell time is 4 seconds at 250 °C.

A mildly-activated flux will eliminate the need for removal of corrosive residues in most applications.

MANUAL SOLDERING

Fix the component by first soldering two diagonally-opposite end leads. Use a low voltage (24 V or less) soldering iron applied to the flat part of the lead. Contact time must be limited to 10 seconds at up to 300 °C.

When using a dedicated tool, all other leads can be soldered in one operation within 2 to 5 seconds between 270 and 320 °C.

2 × 50 W class-D power amplifier**TDA8920****Suitability of IC packages for wave, reflow and dipping soldering methods**

MOUNTING	PACKAGE	SOLDERING METHOD		
		WAVE	REFLOW ⁽¹⁾	DIPPING
Through-hole mount	DBS, DIP, HDIP, SDIP, SIL	suitable ⁽²⁾	–	suitable
Surface mount	BGA, SQFP	not suitable	suitable	–
	HLQFP, HSQFP, HSOP, HTSSOP, SMS	not suitable ⁽³⁾	suitable	–
	PLCC ⁽⁴⁾ , SO, SOJ	suitable	suitable	–
	LQFP, QFP, TQFP	not recommended ⁽⁴⁾⁽⁵⁾	suitable	–
	SSOP, TSSOP, VSO	not recommended ⁽⁶⁾	suitable	–

Notes

- All surface mount (SMD) packages are moisture sensitive. Depending upon the moisture content, the maximum temperature (with respect to time) and body size of the package, there is a risk that internal or external package cracks may occur due to vaporization of the moisture in them (the so called popcorn effect). For details, refer to the Drypack information in the *"Data Handbook IC26; Integrated Circuit Packages; Section: Packing Methods"*.
- For SDIP packages, the longitudinal axis must be parallel to the transport direction of the printed-circuit board.
- These packages are not suitable for wave soldering as a solder joint between the printed-circuit board and heatsink (at bottom version) can not be achieved, and as solder may stick to the heatsink (on top version).
- If wave soldering is considered, then the package must be placed at a 45° angle to the solder wave direction. The package footprint must incorporate solder thieves downstream and at the side corners.
- Wave soldering is only suitable for LQFP, QFP and TQFP packages with a pitch (e) equal to or larger than 0.8 mm; it is definitely not suitable for packages with a pitch (e) equal to or smaller than 0.65 mm.
- Wave soldering is only suitable for SSOP and TSSOP packages with a pitch (e) equal to or larger than 0.65 mm; it is definitely not suitable for packages with a pitch (e) equal to or smaller than 0.5 mm.

DEFINITIONS

Data sheet status	
Objective specification	This data sheet contains target or goal specifications for product development.
Preliminary specification	This data sheet contains preliminary data; supplementary data may be published later.
Product specification	This data sheet contains final product specifications.
Limiting values	
Limiting values given are in accordance with the Absolute Maximum Rating System (IEC 134). Stress above one or more of the limiting values may cause permanent damage to the device. These are stress ratings only and operation of the device at these or at any other conditions above those given in the Characteristics sections of the specification is not implied. Exposure to limiting values for extended periods may affect device reliability.	
Application information	
Where application information is given, it is advisory and does not form part of the specification.	

LIFE SUPPORT APPLICATIONS

These products are not designed for use in life support appliances, devices, or systems where malfunction of these products can reasonably be expected to result in personal injury. Philips customers using or selling these products for use in such applications do so at their own risk and agree to fully indemnify Philips for any damages resulting from such improper use or sale.

Philips Semiconductors – a worldwide company

Argentina: see South America

Australia: 34 Waterloo Road, NORTH RYDE, NSW 2113, Tel. +61 2 9805 4455, Fax. +61 2 9805 4466

Austria: Computerstr. 6, A-1101 WIEN, P.O. Box 213, Tel. +43 160 1010, Fax. +43 160 101 1210

Belarus: Hotel Minsk Business Center, Bld. 3, r. 1211, Volodarski Str. 6, 220050 MINSK, Tel. +375 172 200 733, Fax. +375 172 200 773

Belgium: see The Netherlands

Brazil: see South America

Bulgaria: Philips Bulgaria Ltd., Energoproject, 15th floor, 51 James Bourchier Blvd., 1407 SOFIA, Tel. +359 2 689 211, Fax. +359 2 689 102

Canada: PHILIPS SEMICONDUCTORS/COMPONENTS, Tel. +1 800 234 7381

China/Hong Kong: 501 Hong Kong Industrial Technology Centre, 72 Tat Chee Avenue, Kowloon Tong, HONG KONG, Tel. +852 2319 7888, Fax. +852 2319 7700

Colombia: see South America

Czech Republic: see Austria

Denmark: Prags Boulevard 80, PB 1919, DK-2300 COPENHAGEN S, Tel. +45 32 88 2636, Fax. +45 31 57 0044

Finland: Sinikalliontie 3, FIN-02630 ESPOO, Tel. +358 9 615800, Fax. +358 9 61580920

France: 51 Rue Carnot, BP317, 92156 SURESNES Cedex, Tel. +33 1 40 99 6161, Fax. +33 1 40 99 6427

Germany: Hammerbrookstraße 69, D-20097 HAMBURG, Tel. +49 40 23 53 60, Fax. +49 40 23 536 300

Greece: No. 15, 25th March Street, GR 17778 TAVROS/ATHENS, Tel. +30 1 4894 339/239, Fax. +30 1 4814 240

Hungary: see Austria

India: Philips INDIA Ltd, Band Box Building, 2nd floor, 254-D, Dr. Annie Besant Road, Worli, MUMBAI 400 025, Tel. +91 22 493 8541, Fax. +91 22 493 0966

Indonesia: PT Philips Development Corporation, Semiconductors Division, Gedung Philips, Jl. Buncit Raya Kav.99-100, JAKARTA 12510, Tel. +62 21 794 0040 ext. 2501, Fax. +62 21 794 0080

Ireland: Newstead, Clonskeagh, DUBLIN 14, Tel. +353 1 7640 000, Fax. +353 1 7640 200

Israel: RAPAC Electronics, 7 Kehilat Saloniki St, PO Box 18053, TEL AVIV 61180, Tel. +972 3 645 0444, Fax. +972 3 649 1007

Italy: PHILIPS SEMICONDUCTORS, Piazza IV Novembre 3, 20124 MILANO, Tel. +39 2 6752 2531, Fax. +39 2 6752 2557

Japan: Philips Bldg 13-37, Kohnan 2-chome, Minato-ku, TOKYO 108-8507, Tel. +81 3 3740 5130, Fax. +81 3 3740 5077

Korea: Philips House, 260-199 Itaewon-dong, Yongsan-ku, SEOUL, Tel. +82 2 709 1412, Fax. +82 2 709 1415

Malaysia: No. 76 Jalan Universiti, 46200 PETALING JAYA, SELANGOR, Tel. +60 3 750 5214, Fax. +60 3 757 4880

Mexico: 5900 Gateway East, Suite 200, EL PASO, TEXAS 79905, Tel. +9-5 800 234 7381

Middle East: see Italy

Netherlands: Postbus 90050, 5600 PB EINDHOVEN, Bldg. VB, Tel. +31 40 27 82785, Fax. +31 40 27 88399

New Zealand: 2 Wagener Place, C.P.O. Box 1041, AUCKLAND, Tel. +64 9 849 4160, Fax. +64 9 849 7811

Norway: Box 1, Manglerud 0612, OSLO, Tel. +47 22 74 8000, Fax. +47 22 74 8341

Pakistan: see Singapore

Philippines: Philips Semiconductors Philippines Inc., 106 Valero St. Salcedo Village, P.O. Box 2108 MCC, MAKATI, Metro MANILA, Tel. +63 2 816 6380, Fax. +63 2 817 3474

Poland: Ul. Lukiska 10, PL 04-123 WARSZAWA, Tel. +48 22 612 2831, Fax. +48 22 612 2327

Portugal: see Spain

Romania: see Italy

Russia: Philips Russia, Ul. Usatcheva 35A, 119048 MOSCOW, Tel. +7 095 755 6918, Fax. +7 095 755 6919

Singapore: Lorong 1, Toa Payoh, SINGAPORE 319762, Tel. +65 350 2538, Fax. +65 251 6500

Slovakia: see Austria

Slovenia: see Italy

South Africa: S.A. PHILIPS Pty Ltd., 195-215 Main Road Martindale, 2092 JOHANNESBURG, P.O. Box 7430 Johannesburg 2000, Tel. +27 11 470 5911, Fax. +27 11 470 5494

South America: Al. Vicente Pinzon, 173, 6th floor, 04547-130 SÃO PAULO, SP, Brazil, Tel. +55 11 821 2333, Fax. +55 11 821 2382

Spain: Balmes 22, 08007 BARCELONA, Tel. +34 93 301 6312, Fax. +34 93 301 4107

Sweden: Kottbygatan 7, Akalla, S-16485 STOCKHOLM, Tel. +46 8 5985 2000, Fax. +46 8 5985 2745

Switzerland: Allmendstrasse 140, CH-8027 ZÜRICH, Tel. +41 1 488 2741 Fax. +41 1 488 3263

Taiwan: Philips Semiconductors, 6F, No. 96, Chien Kuo N. Rd., Sec. 1, TAIPEI, Taiwan Tel. +886 2 2134 2865, Fax. +886 2 2134 2874

Thailand: PHILIPS ELECTRONICS (THAILAND) Ltd., 209/2 Sanpavuth-Bangna Road Prakanong, BANGKOK 10260, Tel. +66 2 745 4090, Fax. +66 2 398 0793

Turkey: Talatpasa Cad. No. 5, 80640 GÜLTEPE/ISTANBUL, Tel. +90 212 279 2770, Fax. +90 212 282 6707

Ukraine: PHILIPS UKRAINE, 4 Patrice Lumumba str., Building B, Floor 7, 252042 KIEV, Tel. +380 44 264 2776, Fax. +380 44 268 0461

United Kingdom: Philips Semiconductors Ltd., 276 Bath Road, Hayes, MIDDLESEX UB3 5BX, Tel. +44 181 730 5000, Fax. +44 181 754 8421

United States: 811 East Arques Avenue, SUNNYVALE, CA 94088-3409, Tel. +1 800 234 7381

Uruguay: see South America

Vietnam: see Singapore

Yugoslavia: PHILIPS, Trg N. Pasica 5/v, 11000 BEOGRAD, Tel. +381 11 625 344, Fax. +381 11 635 777

For all other countries apply to: Philips Semiconductors, International Marketing & Sales Communications, Building BE-p, P.O. Box 218, 5600 MD EINDHOVEN, The Netherlands, Fax. +31 40 27 24825

Internet: <http://www.semiconductors.philips.com>

© Philips Electronics N.V. 1998

SCA60

All rights are reserved. Reproduction in whole or in part is prohibited without the prior written consent of the copyright owner.

The information presented in this document does not form part of any quotation or contract, is believed to be accurate and reliable and may be changed without notice. No liability will be accepted by the publisher for any consequence of its use. Publication thereof does not convey nor imply any license under patent- or other industrial or intellectual property rights.

Printed in The Netherlands

545102/25/01/pp16

Date of release: 1998 Dec 01

Document order number: 9397 750 04343

Let's make things better.

**Philips
Semiconductors**



PHILIPS