

**Car radio signal processor****Features**

- 4 stereo inputs
- 1 mono input
- Soft-step volume
- Bass, Treble and Loudness control
- Direct-mute and soft-mute
- Internal beep
- Four independent speaker outputs
- Subwoofer stereo output
- Digital control:
  - I<sup>2</sup>C bus interface
  - Audio filter characteristics programmable

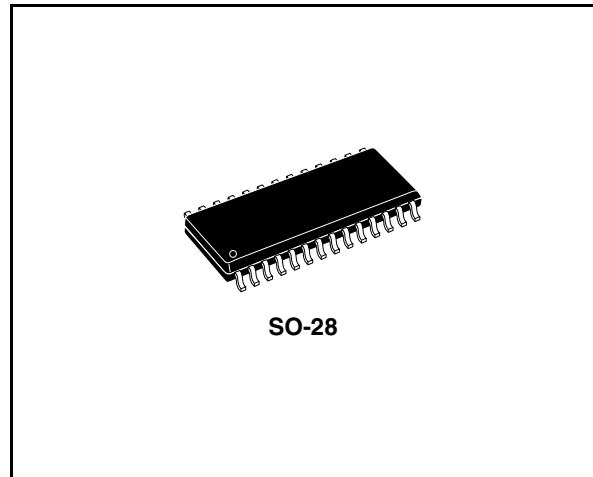

The device includes a high performance audioprocessor with fully integrated audio filters. The digital control allows a programming in a wide range of all the filter characteristics. By the use of a BiCMOS process and a linear signal processing low distortion and low noise are obtained.

**Description**

The TDA7404 is a high performance signal processor specifically designed for car radio applications.

**Table 1. Device summary**

Order code	Package	Packing
TDA7404D	SO-28	Tube

# Contents

- 1 Detailed features ..... 6**
- 2 Block and pin description diagrams ..... 7**
- 3 Electrical specifications ..... 8**
  - 3.1 Supply ..... 8
  - 3.2 Thermal data ..... 8
  - 3.3 Absolute maximum ratings ..... 8
  - 3.4 ESD ..... 8
  - 3.5 Electrical characteristics ..... 9
- 4 Description of functionality ..... 13**
  - 4.1 Input stages ..... 13
  - 4.2 AutoZero ..... 14
    - 4.2.1 AutoZero remain ..... 14
  - 4.3 Mixing stage ..... 14
  - 4.4 Loudness ..... 15
    - 4.4.1 Attenuation ..... 15
    - 4.4.2 Center frequency ..... 15
    - 4.4.3 Low and high frequency boost ..... 16
  - 4.5 Soft-mute ..... 16
  - 4.6 Soft-step volume ..... 17
  - 4.7 Bass ..... 17
    - 4.7.1 Attenuation ..... 17
    - 4.7.2 Center frequency ..... 18
    - 4.7.3 Quality factors ..... 18
    - 4.7.4 DC mode ..... 19
  - 4.8 Treble ..... 20
    - 4.8.1 Attenuation ..... 20
    - 4.8.2 Center frequency ..... 20
  - 4.9 External AC - coupling ..... 21
  - 4.10 Speaker attenuator ..... 21
  - 4.11 Subwoofer attenuator ..... 21

---

<b>5</b>	<b>I2C bus interface</b> .....	<b>22</b>
5.1	Interface protocol .....	22
5.2	Transmitted data (send mode) .....	22
5.3	Reset condition .....	22
5.4	Subaddress (receive mode) .....	23
5.5	Data byte specification .....	24
<b>6</b>	<b>Application circuit</b> .....	<b>32</b>
<b>7</b>	<b>Package information</b> .....	<b>33</b>
<b>8</b>	<b>Revision history</b> .....	<b>34</b>

## List of tables

Table 1.	Device summary . . . . .	1
Table 2.	Supply . . . . .	8
Table 3.	Thermal data . . . . .	8
Table 4.	Absolute maximum ratings . . . . .	8
Table 5.	Electrical characteristics . . . . .	9
Table 6.	Others selection . . . . .	21
Table 7.	Subaddress (receive mode) . . . . .	23
Table 8.	Input selector / gain . . . . .	24
Table 9.	Loudness . . . . .	25
Table 10.	Volume . . . . .	25
Table 11.	Treble programming . . . . .	26
Table 12.	Bass programming . . . . .	27
Table 13.	Speaker attenuator left front . . . . .	28
Table 14.	Speaker attenuator right front . . . . .	28
Table 15.	Speaker attenuator left rear . . . . .	29
Table 16.	Speaker attenuator right rear . . . . .	29
Table 17.	Subwoofer attenuator (left and right) . . . . .	30
Table 18.	Soft-mute and mixing . . . . .	30
Table 19.	Others . . . . .	31
Table 20.	Testing . . . . .	31
Table 21.	Document revision history . . . . .	34

## List of figures

Figure 1.	Block diagram . . . . .	7
Figure 2.	Pin connection (top view) . . . . .	7
Figure 3.	Input stages diagram . . . . .	13
Figure 4.	Signal-flow of mixing-stage . . . . .	14
Figure 5.	Loudness attenuation @ $f_C = 400$ Hz . . . . .	15
Figure 6.	Loudness center frequencies @ Attn. = 15 dB . . . . .	15
Figure 7.	Loudness attenuation, $f_C = 2.4$ kHz . . . . .	16
Figure 8.	Soft-mute timing . . . . .	16
Figure 9.	Soft-step timing . . . . .	17
Figure 10.	Bass control @ $f_C = 80$ Hz, $Q = 1$ . . . . .	17
Figure 11.	Bass center frequencies @ gain = 15 dB, $Q = 1$ . . . . .	18
Figure 12.	Bass quality factors @ gain = 14 dB, $f_C = 80$ Hz . . . . .	18
Figure 13.	Bass normal and DC mode @ gain = 14 dB, $f_C = 80$ Hz . . . . .	19
Figure 14.	Treble control @ $f_C = 17.5$ kHz . . . . .	20
Figure 15.	Treble center frequencies @ Gain = 15 dB . . . . .	20
Figure 16.	External AC coupling . . . . .	21
Figure 17.	Software specification . . . . .	22
Figure 18.	TDA7404 application circuit . . . . .	32
Figure 19.	SO-28 mechanical data and package dimensions . . . . .	33

# 1 Detailed features

- Input multiplexer
  - 1 pseudo-differential stereo input (selectable single end stereo input)
  - 3 single-end stereo inputs
  - 1 differential mono input
  - In-Gain 0..14 dB, 1 dB steps, 14..20 dB, 2 dB steps
  - Auto Zero
- Beep
  - internal beep with 3 frequencies
  - 781 Hz/1.56 kHz/1.8 kHz
- Mixing stage
  - 4 step-mixing-stage with mono or beep as mix-signals
- Loudness
  - second order frequency response
  - programmable center frequency
  - 15 x 1 dB steps
  - selectable low and high frequency boost
  - selectable flat-mode (constant attenuation)
- Volume
  - 1 dB attenuator
  - 100 dB range
  - soft-step control with programmable times
- Bass
  - 2<sup>nd</sup> order frequency response
  - center frequency programmable in 4 steps
  - 60 Hz / 80 Hz / 100 Hz / 200 Hz
  - Q programmable 1.0/1.25/1.5/2.0
  - DC gain programmable
  - $\pm 15$  dB x 1 dB steps
- Treble
  - 2<sup>nd</sup> order frequency response
  - center frequency programmable in 4 steps
  - 10 kHz / 12.5 kHz / 15 kHz / 17.5 kHz
  - $\pm 15$  dB x 1 dB steps
- Speaker
  - 4 independent speaker controls in 1 dB steps
  - control range 50 dB with mute
  - Zero crossing attenuate
- Subwoofer
  - Stereo output
  - attenuator range 50 dB
- Mute functions
  - direct mute
  - digitally controlled Soft Mute with 4 programmable mute-times

## 2 Block and pin description diagrams

Figure 1. Block diagram

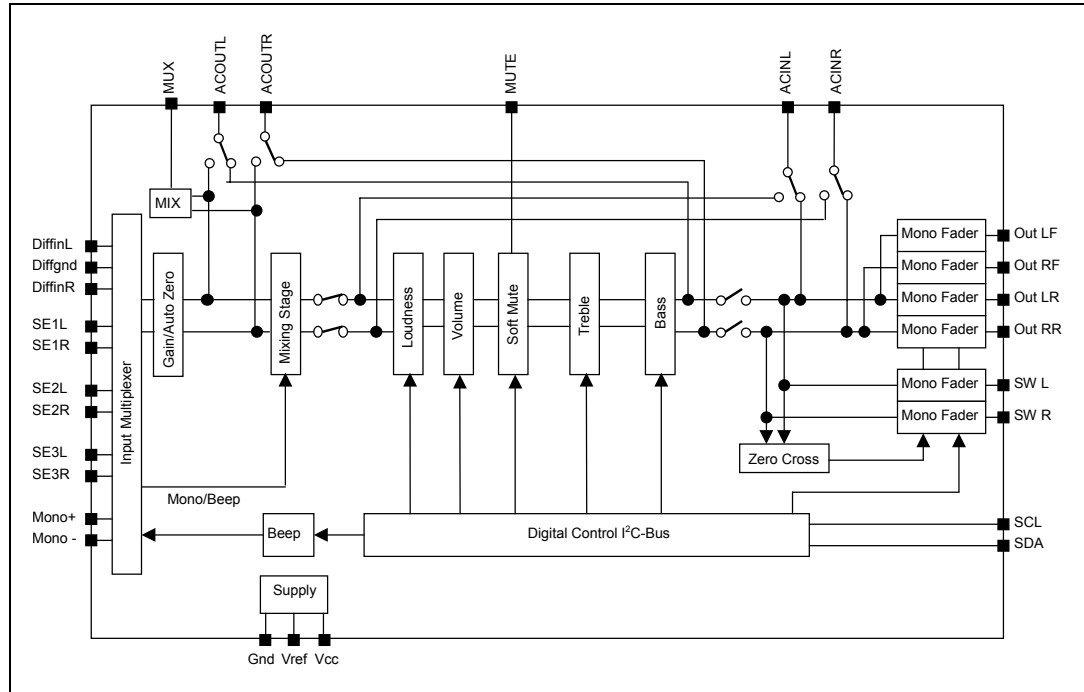
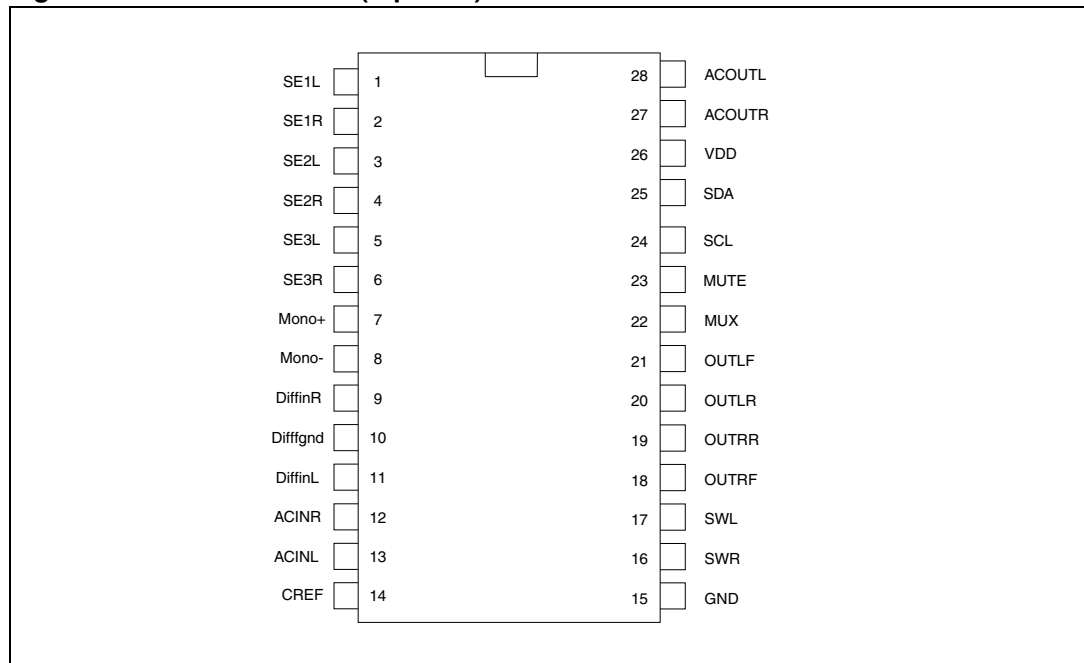

Figure 2. Pin connection (top view)



## 3 Electrical specifications

### 3.1 Supply

Table 2. Supply

Symbol	Parameter	Test condition	Min.	Typ.	Max.	Unit
$V_s$	Supply voltage		7.5	9	10.5	V
$I_s$	Supply current	$V_s = 9V$		20		mA
SVRR	Ripple rejection @ 1 kHz	Audioprocessor (all Filters flat)		60		dB

### 3.2 Thermal data

Table 3. Thermal data

Symbol	Parameter	Value	Unit
$R_{Th\ j-pins}$	Thermal resistance junction pins	max 85	°C/W

### 3.3 Absolute maximum ratings

Table 4. Absolute maximum ratings

Symbol	Parameter	Value	Unit
$V_s$	Operating supply voltage	10.8	V
$T_{amb}$	Operating temperature range	-40 to 85	°C
$T_{stg}$	Storage temperature range	-55 to +150	°C

### 3.4 ESD

All pins are protected against ESD according to the MIL883 standard.



### 3.5 Electrical characteristics

**Table 5. Electrical characteristics**  
( $V_S = 9\text{ V}$ ;  $T_{\text{amb}} = 25\text{ °C}$ ;  $R_L = 10\text{ k}\Omega$ ; all gains = 0 dB;  $f = 1\text{ kHz}$ ; unless otherwise specified)

Symbol	Parameter	Test conditions	Min.	Typ.	Max.	Unit
<b>Input selector</b>						
$R_{\text{in}}$	Input resistance	all single ended Inputs	70	100	130	$\text{k}\Omega$
$V_{\text{CL}}$	Clipping level		2.20	2.60		$V_{\text{RMS}}$
$S_{\text{IN}}$	Input separation		80	100		dB
$G_{\text{IN MIN}}$	Min. input gain		-1	0	1	dB
$G_{\text{IN MAX}}$	Max. input gain		18	20	22	dB
$G_{\text{STEP}}$	Step Resolution		0.5	1	1.5	dB
$V_{\text{DC}}$	DC Steps	Adjacent gain steps	-5	1	5	mV
		$G_{\text{MIN}}$ to $G_{\text{MAX}}$	-10	5	10	mV
$V_{\text{offset}}$	Remaining offset with AutoZero			0.5		mV
<b>P differential stereo inputs</b>						
$R_{\text{in}}$	Input resistance (see <a href="#">Figure 3</a> )	Differential	70	100	130	$\text{k}\Omega$
$G_{\text{CD}}$	Gain	only at true differential input	-0.75	0	0.75	dB
			-5	-6	-7	dB
			-11	-12	-13	dB
CMRR	Common mode rejection ratio	$V_{\text{CM}} = 1\text{ V}_{\text{RMS}}$ @ 1 kHz	40	70		dB
		$V_{\text{CM}} = 1\text{ V}_{\text{RMS}}$ @ 10 kHz	40	60		dB
$e_{\text{NO}}$	Output noise @ speaker-outputs	20 Hz - 20 kHz, flat; all stages 0 dB		9		V
<b>Differential mono input</b>						
$R_{\text{in}}$	Input resistance	Differential	39	56	73	$\text{k}\Omega$
CMRR	Common mode rejection ratio	$V_{\text{CM}} = 1\text{ V}_{\text{RMS}}$ @ 1 kHz	40	70		dB
		$V_{\text{CM}} = 1\text{ V}_{\text{RMS}}$ @ 10 kHz	40	60		dB
<b>Beep control</b>						
$V_{\text{RMS}}$	Beep level		250	350	500	mV
$f_{\text{B}}$	Beep frequency	$f_{\text{B1}}$	740	781	820	Hz
		$f_{\text{B2}}$	1.48	1.56	1.64	kHz
		$f_{\text{B3}}$	1.7	1.8	1.9	kHz

**Table 5. Electrical characteristics (continued)**  
 ( $V_S = 9\text{ V}$ ;  $T_{amb} = 25\text{ °C}$ ;  $R_L = 10\text{ k}\Omega$ ; all gains = 0 dB;  $f = 1\text{ kHz}$ ; unless otherwise specified)

Symbol	Parameter	Test conditions	Min.	Typ.	Max.	Unit
<b>Mixing control</b>						
$M_{LEVEL}$	Mixing level	Main / mix-source		0/00		dB
		Main / mix-source	-8.5/-10.6	-3.5/-9.6	-2.5/-8.6	dB
		Main / mix-source	-5/-5	-6/-6	-7/-7	dB
		Main / mix-source	-11/-1.5	-12/-2.5	-13/-3.5	dB
<b>Volume control</b>						
$G_{MAX}$	Max. gain		28	30	32	dB
$A_{MAX}$	Max. attenuation		-83	-79	-75	dB
$A_{STEP}$	Step resolution		0.5	1	1.5	dB
$E_A$	Attenuation set error	G = -20 to +20 dB	-1	0	1	dB
		G = -80 to -20 dB	-4	0	3	dB
$E_T$	Tracking error				2	dB
$V_{DC}$	DC steps	Adjacent steps		0.1	3	mV
		From 0 dB to $G_{MIN}$		0.5	5	mV
<b>Loudness control</b>						
$A_{STEP}$	Step resolution		-0.5	1	1.5	dB
$A_{MAX}$	Max. attenuation		13	15	17	dB
$f_C$	Center frequency		360	400	440	Hz
			720	800	880	Hz
			2.3	2.4 <sup>(1)</sup>	2.5	kHz
<b>Soft-mute</b>						
$A_{MUTE}$	Mute attenuation		80	100		dB
$T_D$	Delay time	T1		0.48	1	ms
		T2		0.96	2	ms
		T3	20	30.7	50	ms
		T4	70	123	170	ms
$V_{TH\ low}$	Low threshold for SM pin <sup>(2)</sup>				1	V
$V_{TH\ high}$	High threshold for SM pin		2.50			V
$R_{PU}$	Internal pull-up resistor		70	100	130	k $\Omega$
$V_{PU}$	Pull-up voltage			5		V

Table 5. Electrical characteristics (continued)

(V<sub>S</sub> = 9 V; T<sub>amb</sub> = 25 °C; R<sub>L</sub> = 10 kΩ; all gains = 0 dB; f = 1 kHz; unless otherwise specified)

Symbol	Parameter	Test conditions	Min.	Typ.	Max.	Unit
<b>Soft-step</b>						
T <sub>SW</sub>	Switch time	T <sub>SW1</sub>		0.68		ms
		T <sub>SW2</sub>		1.26		ms
		T <sub>SW3</sub>		2.52		ms
		T <sub>SW4</sub>		5.04		ms
<b>Bass control</b>						
C <sub>RANGE</sub>	Control range		±14	±15	±16	dB
A <sub>STEP</sub>	Step resolution		0.5	1	1.5	dB
f <sub>C</sub>	Center frequency	f <sub>C1</sub>	54	60	66	Hz
		f <sub>C2</sub>	72	80	88	Hz
		f <sub>C3</sub>	90	100	110	Hz
		f <sub>C4</sub>	180	200	220	Hz
Q <sub>BASS</sub>	Quality factor	Q <sub>1</sub>	0.9	1	1.1	
		Q <sub>2</sub>	1.1	1.25	1.4	
		Q <sub>3</sub>	1.3	1.5	1.7	
		Q <sub>4</sub>	1.8	2	2.2	
DC <sub>GAIN</sub>	Bass DC gain	DC = off	-1	0	1	dB
		DC = on	4	4.4	6	dB
<b>Treble control</b>						
C <sub>RANGE</sub>	Control range		±14	±15	±16	dB
A <sub>STEP</sub>	Step resolution		0.5	1	1.5	dB
f <sub>C</sub>	Center frequency	f <sub>C1</sub>	8	10	12	kHz
		f <sub>C2</sub>	10	12.5	15	kHz
		f <sub>C3</sub>	12	15	18	kHz
		f <sub>C4</sub>	14	17.5	21	kHz
<b>Speaker attenuator</b>						
C <sub>RANGE</sub>	Control range		-53	50	-47	dB
A <sub>STEP</sub>	Step resolution	Only for attenuation up to 24 dB	0.5	1	1.5	dB
A <sub>MUTE</sub>	Output mute attenuation		80	90		dB
E <sub>E</sub>	Attenuation set error		-2		2	dB
V <sub>DC</sub>	DC steps	Adjacent attenuation steps		0.10	5	mV
T <sub>ZC</sub>	Zero cross timer	Data bit D1=1, D2=1	29	37	45	ms
V <sub>th</sub>	Zero cross threshold			±20		mV

**Table 5. Electrical characteristics (continued)** $(V_S = 9\text{ V}; T_{\text{amb}} = 25\text{ }^\circ\text{C}; R_L = 10\text{ k}\Omega; \text{all gains} = 0\text{ dB}; f = 1\text{ kHz}; \text{unless otherwise specified})$ 

Symbol	Parameter	Test conditions	Min.	Typ.	Max.	Unit
<b>Fader outputs</b>						
$V_{\text{CLIP}}$	Clipping level	$d = 0.3\%$	2.20	2.60		$V_{\text{RMS}}$
$R_L$	Output load resistance		2			$\text{k}\Omega$
$C_L$	Output load capacitance				10	nF
$R_{\text{OUT}}$	Output impedance			30	100	$\Omega$
$V_{\text{DC}}$	DC Voltage Level		4.3	4.5	4.7	V
<b>Subwoofer attenuator</b>						
$C_{\text{RANGE}}$	Control range		-53	50	-47	dB
$A_{\text{STEP}}$	Step resolution		0.5	1	1.5	dB
$A_{\text{MUTE}}$	Output mute attenuation		80	90		dB
$E_E$	Attenuation set error				2	dB
$V_{\text{DC}}$	DC steps	Adjacent attenuation steps		0.10	5	mV
<b>General</b>						
$e_{\text{NO}}$	Output noise	BW = 20 Hz - 20 kHz all gains = 0 dB single ended inputs		10	15	$\mu\text{V}$
S/N	Signal to noise ratio	all gains = 0 dB flat; $V_O = 2V_{\text{RMS}}$		106		dB
		bass, treble at +12 dB; a-weighted; $V_O = 2.6 V_{\text{RMS}}$		100		dB
d	Distortion	$V_{\text{IN}} = 1 V_{\text{RMS}}$ ; all stages 0 dB internal pass only		0.005	0.1	%
		$V_{\text{OUT}} = 1 V_{\text{RMS}}$ ; Bass and treble = 12 dB		0.05	0.1	%
$S_C$	Channel separation left/right		80	100		dB
$E_T$	Total tracking error	$A_V = 0$ to -20 dB	-1	0	1	dB
		$A_V = -20$ to -60 dB	-2	0	2	dB

1. The SM-Pin is active low (Mute = 0).
2. Center frequency 2.4 kHz makes 1kHz bottom frequency at low and high frequency boost condition.

## 4 Description of functionality

### 4.1 Input stages

Most of the input stages have remained the same as in preceding ST-Audioprocessors with exception of the CD-inputs (see [Figure 3](#)). In the meantime there are some CD-players in the market which have a significant high source-impedance which effects strongly the common-mode-rejection of the normal differential input stage.

The additional buffer of the TDA7404 Diff:

- input avoids this drawback and offers the full common-mode-rejection even with those CD-players.

**Figure 3. Input stages diagram**

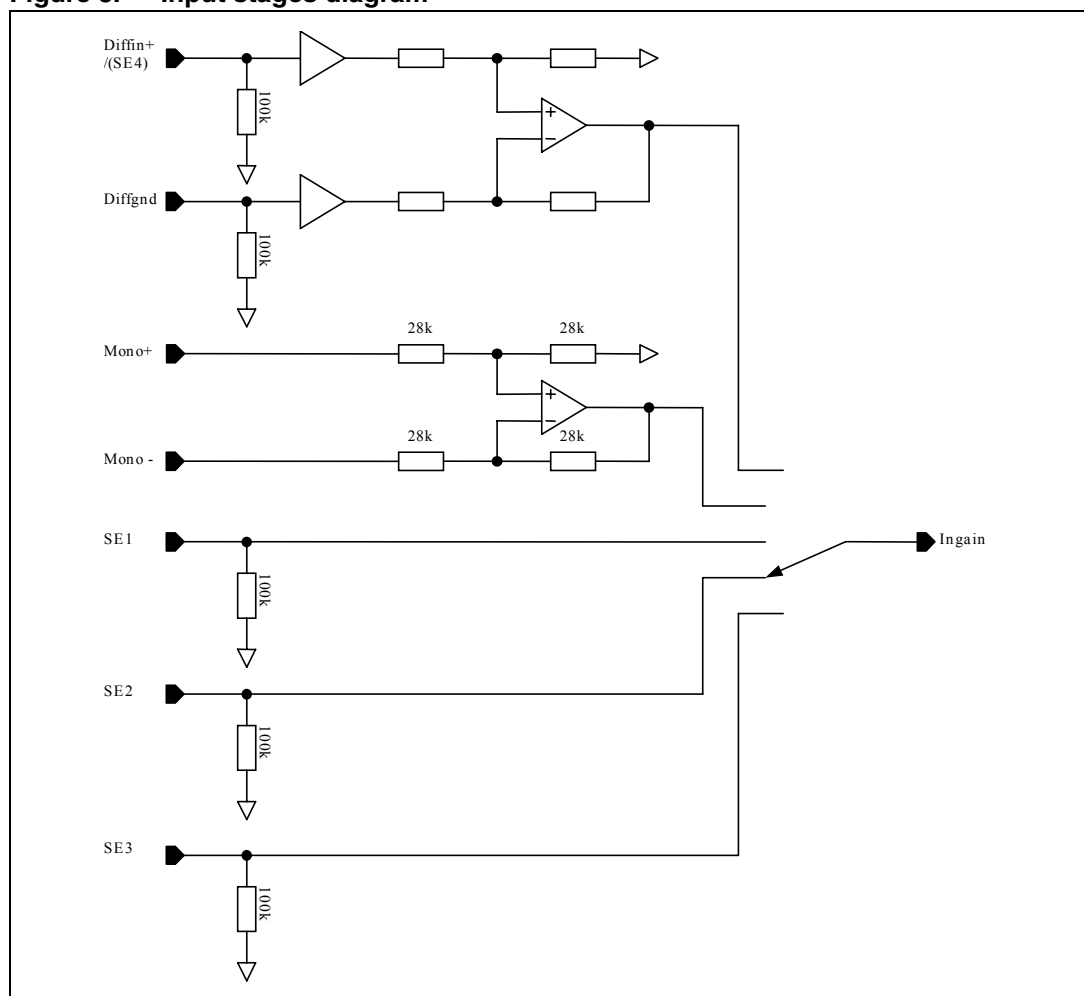

1. It is possible that the Differential input is switched a single ended input (SE4) like SE1.. 3.

## 4.2 AutoZero

In order to reduce the number of pins there is no AC coupling between the In-Gain and the following stage, so that any offset generated by or before the In-Gain-stage would be transferred or even amplified to the output. To avoid that effect a special Offset-cancellation-stage called AutoZero is implemented. This stage is located before the Mixing-block to eliminate all offsets generated by the Input-Stages and the In-Gain (Please notice that externally generated offsets, e.g. generated through the leakage current of the coupling capacitors, are not canceled).

The auto-zeroing is started every time the DATA-BYTE 0 (Input Selector/Gain) is selected and takes a time of max. **0.3ms**. To avoid audible clicks the Audioprocessor is muted before the loudness stage during this time.

### 4.2.1 AutoZero remain

In some cases, for example if the  $\mu\text{P}$  is executing a refresh cycle of the IIC-Bus-programming, it is not useful to start a new AutoZero-action because no new source is selected and an undesired mute would appear at the outputs. For such applications the TDA7404 could be switched in the **AutoZero-Remain-Mode** (12 bit of the subaddress-byte). If this bit is set to high, the DATABYTE 0 could be loaded without invoking the AutoZero and the old adjustment-value remains.

## 4.3 Mixing stage

The 4 step Mixing stage offers the possibility to mix the rear selector signal or the phone signal to any other source. Due to the fact that the mixing-stage is located behind the In-Gain-stage fine adjustments of the main source level could be done in this way.

Figure 4. Signal-flow of mixing-stage

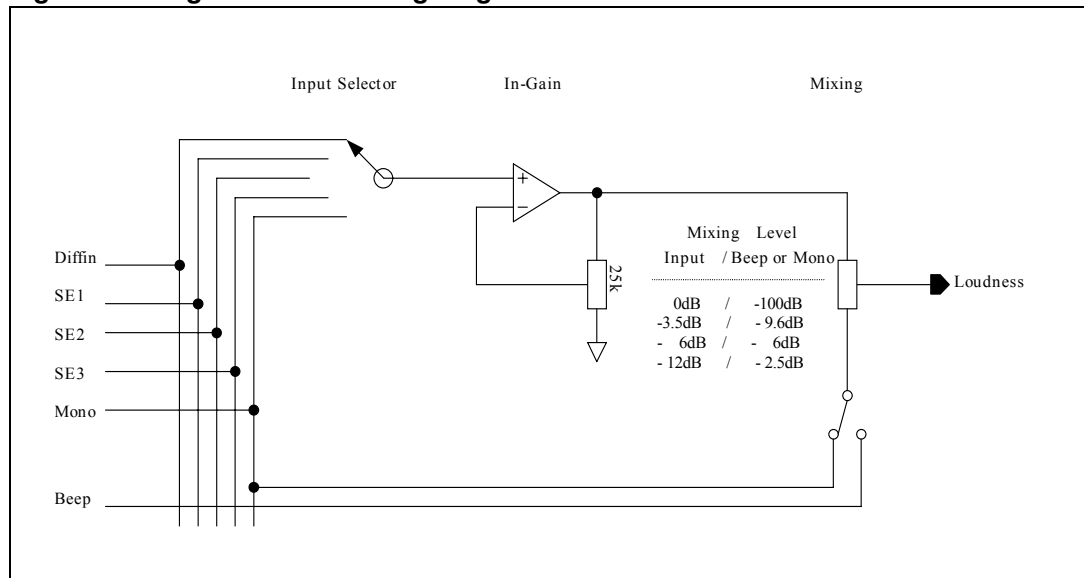

## 4.4 Loudness

There are four parameters programmable in the loudness stage:

### 4.4.1 Attenuation

*Figure 5* shows the attenuation as a function of frequency at  $f_C = 400$  Hz.

**Figure 5. Loudness attenuation @  $f_C = 400$  Hz**

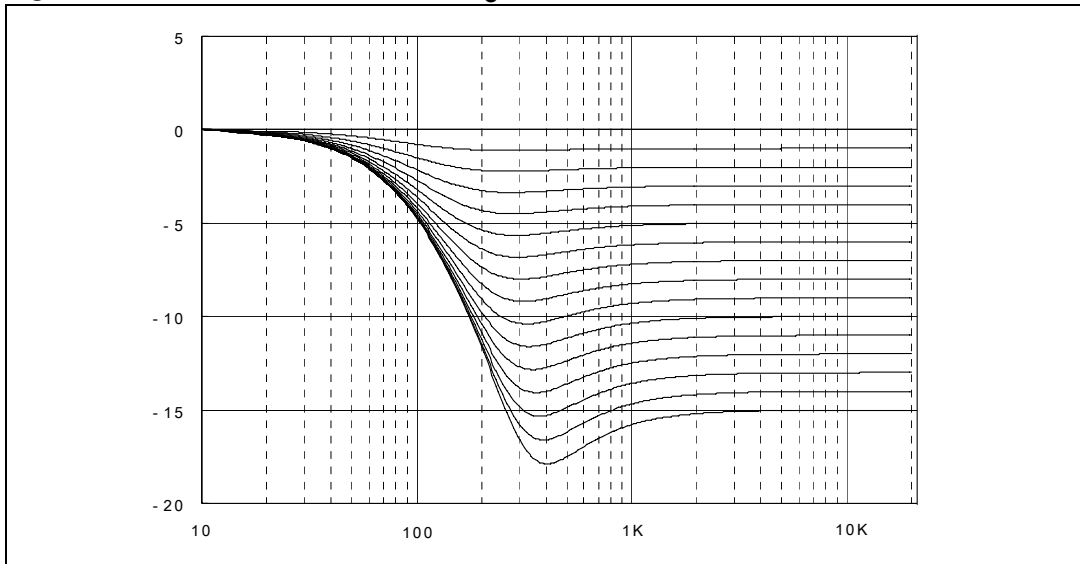

### 4.4.2 Center frequency

*Figure 6* shows the three possible peak-frequencies 400 Hz, 800 Hz and 2.4 kHz.

**Figure 6. Loudness center frequencies @ Attn. = 15 dB**

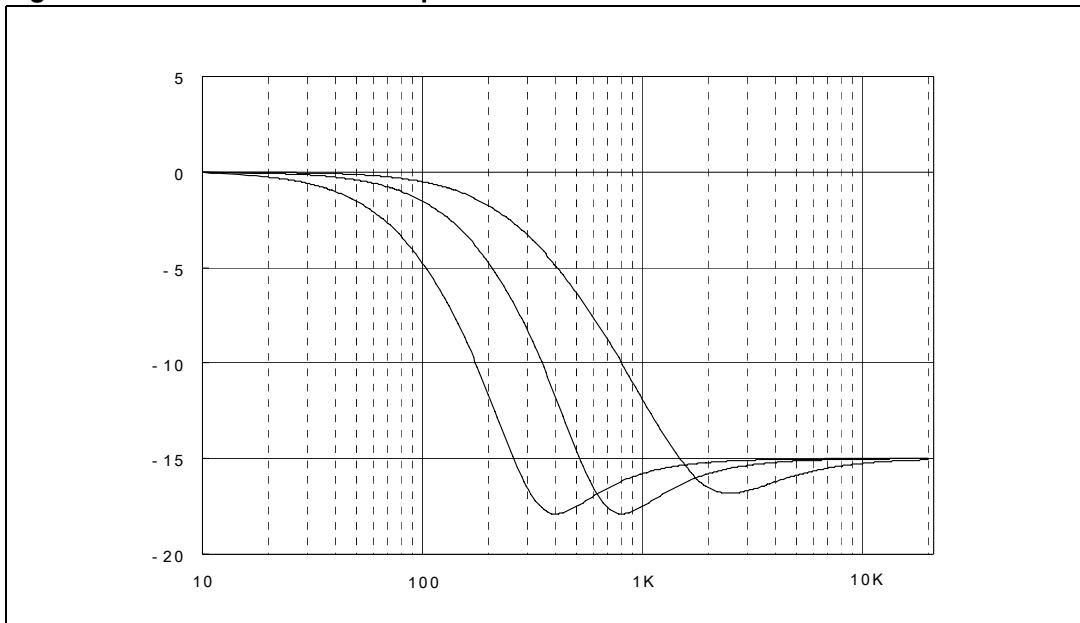

### 4.4.3 Low and high frequency boost

Figure 7 shows the different Loudness-shapes in low & high frequency boost.

Figure 7. Loudness attenuation,  $f_c = 2.4 \text{ kHz}$

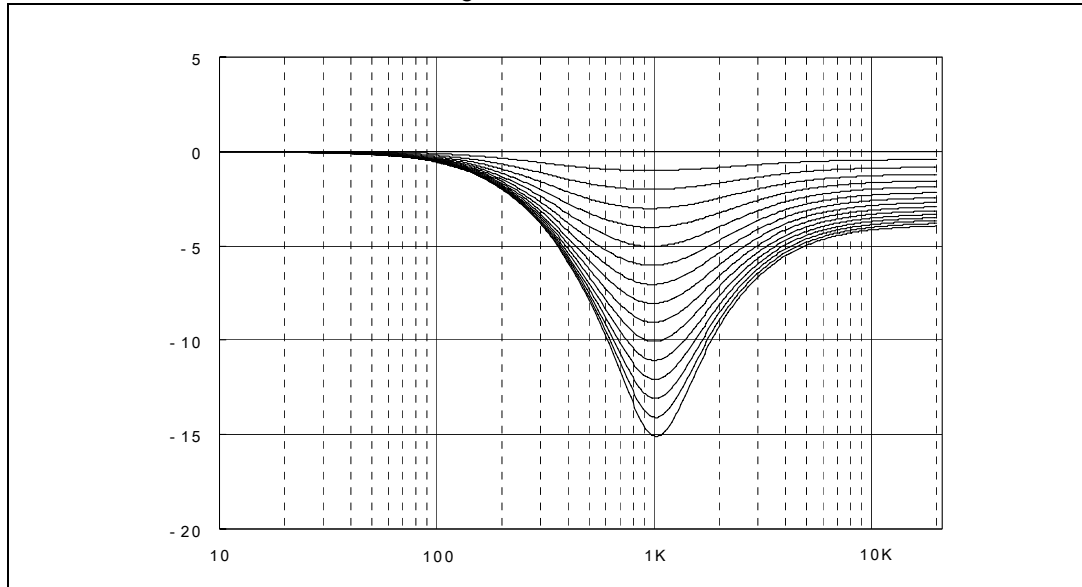

### 4.5 Soft-mute

The digitally controlled soft-mute stage allows muting/demuting the signal with a I<sup>2</sup>C bus programmable slope. The mute process can either be activated by the Mute pin or by the I<sup>2</sup>C bus. This slope is realized in a special S-shaped curve to mute slow in the critical regions (see Figure 6).

For timing purposes the Bit 0 of the I<sup>2</sup>C bus output register is set to 1 from the start of muting until the end of de-muting.

Figure 8. Soft-mute timing

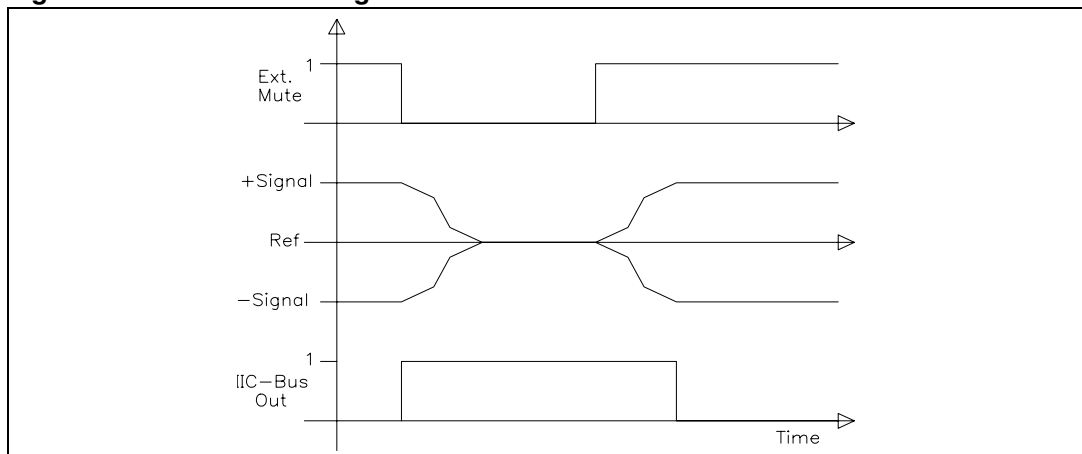

1. Please notice that a started Mute-action is always terminated and could not be interrupted by a change of the mute -signal.



## 4.6 Soft-step volume

When the volume-level is changed audible clicks could appear at the output. The root cause of those clicks could either be a DC-Offset before the volume-stage or the sudden change of the envelope of the audiosignal. With the soft-step feature both kinds of clicks could be reduced to a minimum and are no more audible. Four programmable soft step time from one step to the next, are user selectable.

**Figure 9. Soft-step timing**

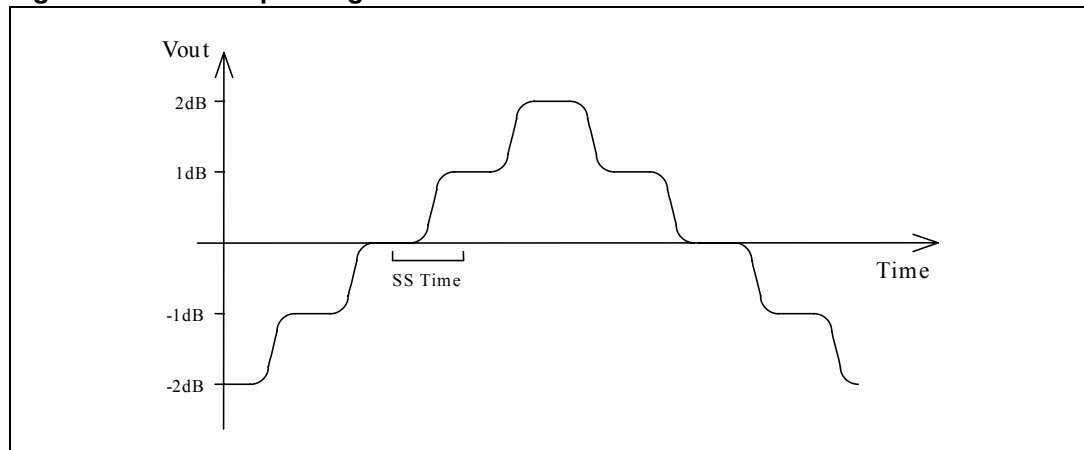

1. For steps more than 1 dB the soft-step mode should be deactivated because it could generate a 1 dB error during the blend-time.

## 4.7 Bass

There are three parameters programmable in the bass stage:

### 4.7.1 Attenuation

*Figure 10* shows the attenuation as a function of frequency at a center frequency of 80Hz.

**Figure 10. Bass control @  $f_c = 80 \text{ Hz}$ ,  $Q = 1$**

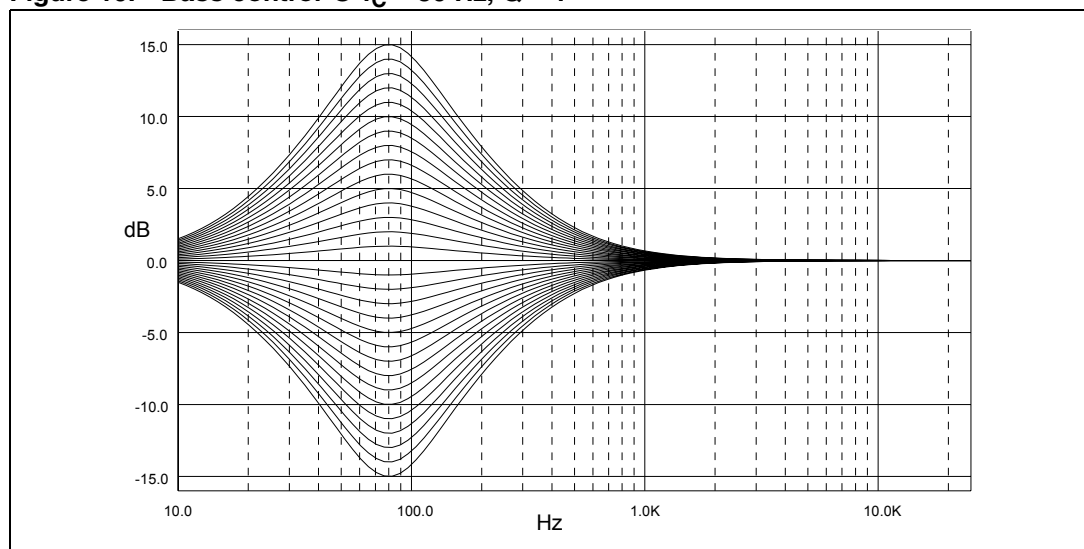

### 4.7.2 Center frequency

Figure 11 shows the four possible center frequencies 60, 80, 100 and 200 Hz.

Figure 11. Bass center frequencies @ gain = 15 dB, Q = 1

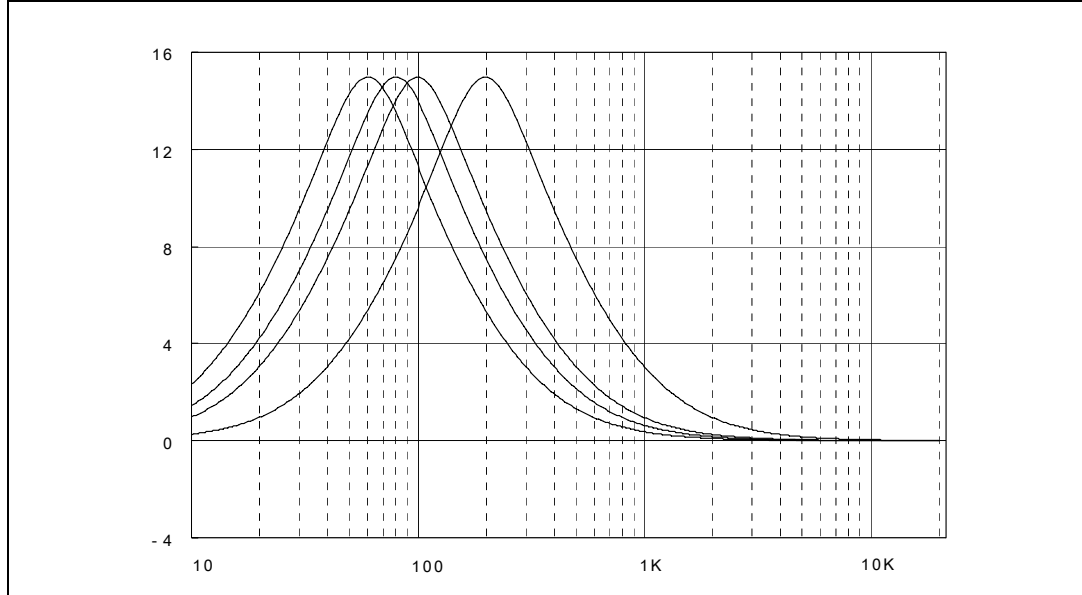

### 4.7.3 Quality factors

Figure 12 shows the four possible quality factors 1, 1.25, 1.5 and 2.

Figure 12. Bass quality factors @ gain = 14 dB,  $f_c = 80$  Hz

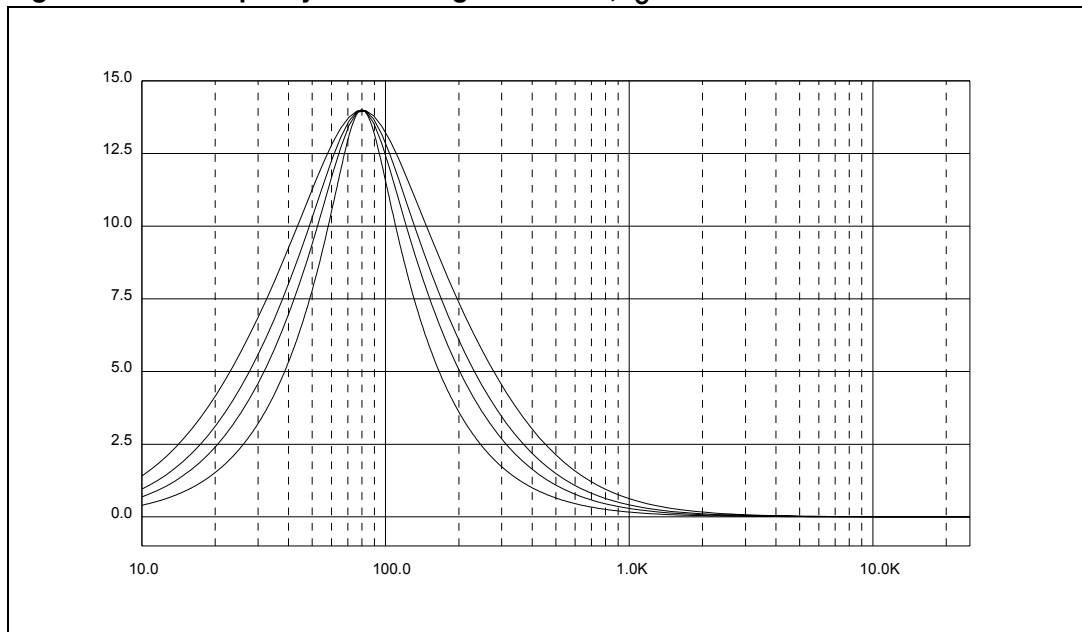

#### 4.7.4 DC mode

In this mode the DC-gain is increased by 4.4 dB. In addition the programmed center frequency and quality factor is decreased by 25 % which can be used to reach alternative center frequencies or quality factors.

**Figure 13. Bass normal and DC mode @ gain = 14 dB,  $f_C = 80$  Hz**

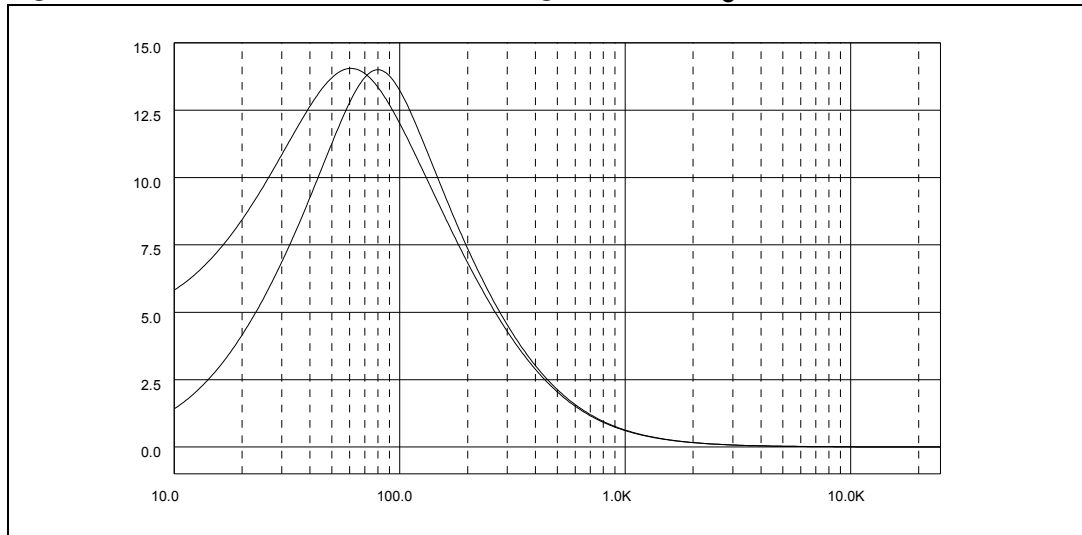

1. The center frequency, Q and DC mode can be set fully independently.

## 4.8 Treble

There are two parameters programmable in the treble stage:

### 4.8.1 Attenuation

Figure 14 shows the attenuation as a function of frequency at a center frequency of 17.5 kHz.

Figure 14. Treble control @  $f_c = 17.5\text{kHz}$

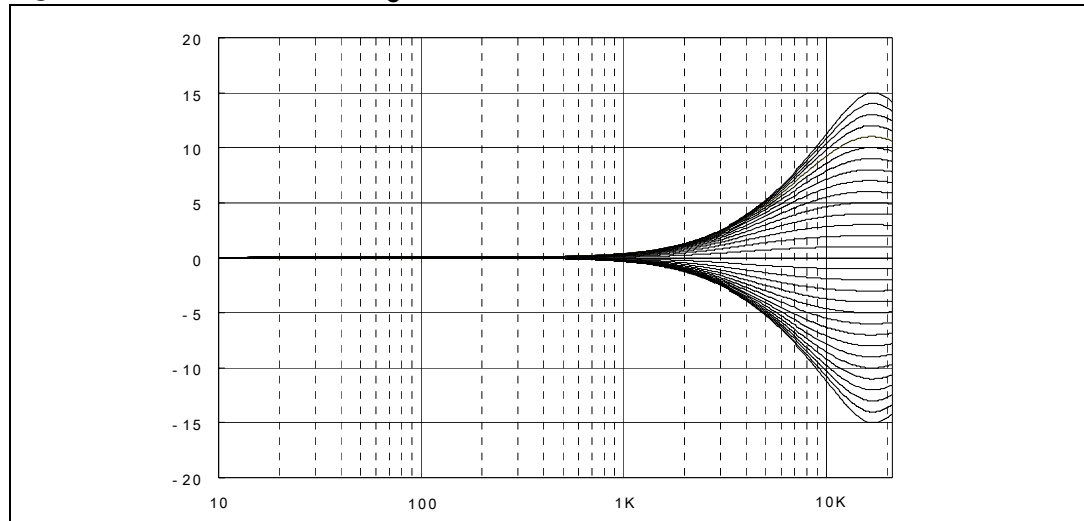

### 4.8.2 Center frequency

Figure 15 shows the four possible center frequencies 10 k, 12.5 k, 15 k and 17.5 kHz.

Figure 15. Treble center frequencies @ Gain = 15 dB

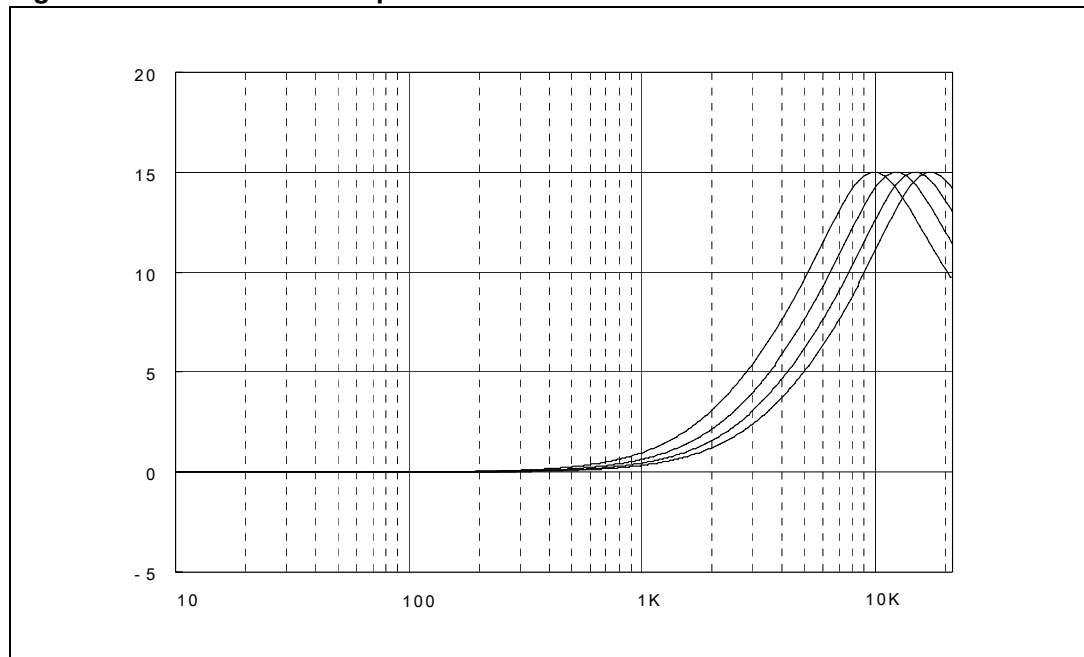

### 4.9 External AC - coupling

TDA7404 has external AC coupling terminals which can be selected one of two positions behind the mixing stage or bass filter.

**Figure 16. External AC coupling**

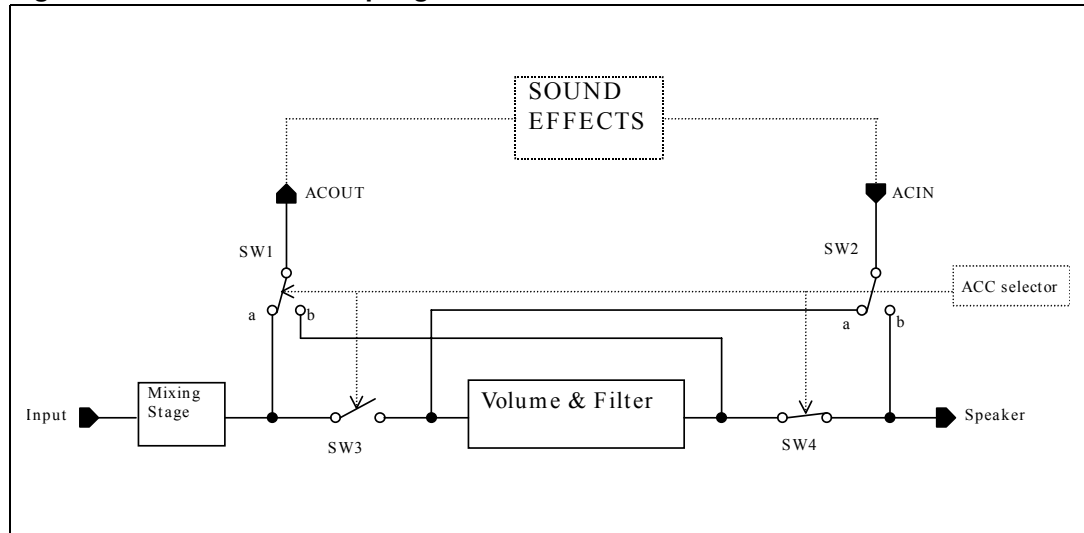

The external AC coupling is selected in position of four switches controlled by the lower 2bit in the Others selection (see [Table 6](#)).

**Table 6. Others selection**

D1	D0	Switch position
X	0	SW3 = ON, SW4 = ON (selected internal pass), SW1 = b, SW2 = open
0	1	SW3 = OFF, SW4 = ON, SW1 = a, SW2 = a
1	1	SW3 = ON, SW4 = OFF, SW1 = b, SW2 = b

### 4.10 Speaker attenuator

Due to practical aspects the steps in the speaker-attenuator are not linear over the full range. At attenuations more than 24 dB the steps increase from 1.5 dB to 10 dB (please see data byte specification).

### 4.11 Subwoofer attenuator

The Subwoofer output is a single ended stereo output. The attenuator is exactly the same like the other speakers.

## 5 I<sup>2</sup>C bus interface

### 5.1 Interface protocol

The interface protocol comprises:

- a start condition (S)
- a chip address byte (the LSB bit determines read / write transmission)
- a subaddress byte
- a sequence of data (N-bytes + acknowledge)
- a stop condition (P)
- the max. clock speed is 500 Kbits/s

**Figure 17. Software specification**

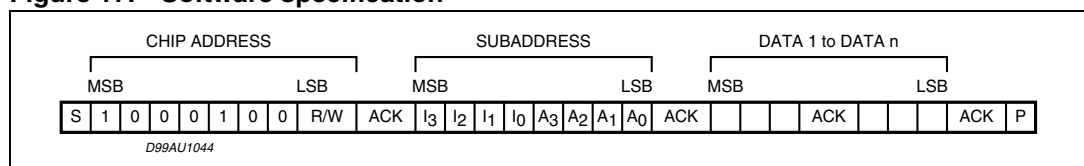

S = Start

R/W = "0" -> Receive-Mode (Chip could be programmed by P)  
 "1" -> Transmission-Mode (Data could be received by P)

ACK = Acknowledge

P = Stop

### 5.2 Transmitted data (send mode)

MSB							LSB
X	X	X	X	X	X	X	SM

SM = Soft mute activated  
 X = Not Used

The transmitted data is automatic updated after each ACK. Transmission can be repeated without new chipaddress.

### 5.3 Reset condition

A Power on reset is invoked if the supply voltage is below than 3.5V. After that the following data is written automatically into the registers of all subaddresses:

MSB							LSB
<b>1</b>	<b>1</b>	<b>1</b>	<b>1</b>	<b>1</b>	<b>1</b>	<b>1</b>	<b>0</b>

The programming after POR is marked bold-face / underlined in the programming tables.

With this programming all the outputs are muted to  $V_{REF}$  ( $V_{OUT} = V_{DD}/2$ ).

Note: All the blank bits in the following tables are "don't care"-bits.

## 5.4 Subaddress (receive mode)

Table 7. Subaddress (receive mode)

MSB				LSB				Function
I <sub>3</sub>	I <sub>2</sub>	I <sub>1</sub>	I <sub>0</sub>	A <sub>3</sub>	A <sub>2</sub>	A <sub>1</sub>	A <sub>0</sub>	
0 1								<b>Zero cross / Soft Mute</b> <sup>(1)</sup> Zero Cross available Soft Mute available
	0 1							<b>AutoZero Remain</b> <sup>(2)</sup> off on
		0 1						<b>Testmode</b> <sup>(3)</sup> off on
			0 1					<b>Auto-Increment Mode</b> <sup>(4)</sup> off on
				0 0 0 0 0 0 0 0 1 1 1 1 1 1	0 0 0 0 1 1 1 0 0 0 0 0 1 1	0 0 1 1 0 0 1 1 0 0 1 0 0 0 0	0 1 0 1 0 1 0 1 0 1 0 1 0 0 0	Input Selector / Gain Loudness Volume Treble Bass Speaker attenuator LF / Bass Fc select Speaker attenuator RF Speaker attenuator LR Speaker attenuator RR Subwoofer attenuator LSW Subwoofer attenuator RSW Soft-mute / Mixing Others selection Testing

1. For more information see [Section 4.5: Soft-mute](#).
2. For more information see [Section 4.2: AutoZero](#)
3. For more information see Test Programming block
4. If this bit is set to "1", the subaddress is automatically increased after the transmission of a data-byte. Therefore a transmission of more than one byte without sending the new subaddress is possible.

## 5.5 Data byte specification

Table 8. Input selector / gain

MSB					LSB			Function
D <sub>7</sub>	D <sub>6</sub>	D <sub>5</sub>	D <sub>4</sub>	D <sub>3</sub>	D <sub>2</sub>	D <sub>1</sub>	D <sub>0</sub>	
					0	0	0	<b>Source selector</b>
					0	0	1	Mono Differential
					0	1	0	Single Ended 1
					0	1	1	Mute
					1	0	0	Single Ended 2
					1	0	1	Pseudo Differential / Single Ended 4
					1	1	0	Single Ended 3
					1	1	1	Mute
								Beep
								<b>Input gain</b>
0	0	0	0	0				0 dB
0	0	0	0	1				1 dB
0	0	0	1	0				2 dB
0	0	0	1	1				3 dB
0	0	1	0	0				4 dB
0	0	1	0	1				5 dB
0	0	1	1	0				6 dB
0	0	1	1	1				7 dB
0	1	0	0	0				8 dB
0	1	0	0	1				9 dB
0	1	0	1	0				10 dB
0	1	0	1	1				11 dB
0	1	1	0	0				12 dB
0	1	1	0	1				13 dB
0	1	1	1	0				14 dB
0	1	1	1	1				16 dB
1	X	X	X	0				18 dB
1	X	X	X	1				20 dB



**Table 9. Loudness**

MSB							LSB		Function
D <sub>7</sub>	D <sub>6</sub>	D <sub>5</sub>	D <sub>4</sub>	D <sub>3</sub>	D <sub>2</sub>	D <sub>1</sub>	D <sub>0</sub>		
				0	0	0	0	<b>Attenuation</b> 0 dB	
				0	0	0	1	-1 dB	
				:	:	:	:	:	
				1	1	1	0	-14 dB	
				1	1	1	1	-15 dB	
	0	0	0					<b>Filter / Center Frequency</b> off (flat) 'D6 must be = 0'	
		0	1					400 Hz	
		1	0					800 Hz	
		1	1					2.4 kHz	
	0							<b>Shape</b> Low boost	
	1							Low and high boost	
0								<b>Soft-step-Volume</b> off	
1								on	

Note 1: The attenuation is specified at high frequencies. Around the center frequency the value is different depending on the programmed attenuation (see [Section 4.4: Loudness](#)).

**Table 10. Volume**

MSB							LSB		Function
D <sub>7</sub>	D <sub>6</sub>	D <sub>5</sub>	D <sub>4</sub>	D <sub>3</sub>	D <sub>2</sub>	D <sub>1</sub>	D <sub>0</sub>		
	0	0	0	0	0	0	0	<b>Gain/attenuation</b> not allow	
	0	0	0	0	0	0	1	not allow	
	0	0	0	0	0	1	0	+30.0 dB	
	0	0	0	0	0	1	1	+29.0 dB	
								:	
	0	0	1	1	1	1	1	+1.0 dB	
	0	1	0	0	0	0	0	0.0 dB	
	0	1	0	0	0	0	1	- 1.0 dB	
	0	1	0	0	0	1	0	- 2.0 dB	
							1	:	
	1	1	0	1	1	1	0	-78.0 dB	
	1	1	0	1	1	1	1	-79.0 dB	
	1	1	1	X	X	X	X	Mute	
0								<b>Diffin - mode</b> Single ended stereo	
1								<u>Differential Stereo</u>	

Note 2: It is not recommended to use a gain more than 20 dB for system performance reason. In general, the max. gain should be limited by software to the maximum value, which is needed for the system.

Table 11. Treble programming

MSB				LSB				Function
D <sub>7</sub>	D <sub>6</sub>	D <sub>5</sub>	D <sub>4</sub>	D <sub>3</sub>	D <sub>2</sub>	D <sub>1</sub>	D <sub>0</sub>	
				0	0	0	0	<b>Treble Steps</b> 15 dB
				0	0	0	1	14 dB
				0	0	1	0	13 dB
				0	0	1	1	12 dB
				0	1	0	0	11 dB
				0	1	0	1	10 dB
				0	1	1	0	9 dB
				0	1	1	1	8 dB
				1	0	0	0	7 dB
				1	0	0	1	6 dB
				1	0	1	0	5 dB
				1	0	1	1	4 dB
				1	1	0	0	3 dB
				1	1	0	1	2 dB
				1	1	1	0	<b>1 dB</b>
				1	1	1	1	0 dB
			0					<b>Mode</b> Cut
			1					<b>Boost</b>
X	0	0						<b>Treble Center Frequency</b> 10 kHz
X	0	1						12.5 kHz
X	1	0						15 kHz
X	1	1						17.5 kHz

**Table 12. Bass programming**

MSB				LSB				Function
D <sub>7</sub>	D <sub>6</sub>	D <sub>5</sub>	D <sub>4</sub>	D <sub>3</sub>	D <sub>2</sub>	D <sub>1</sub>	D <sub>0</sub>	
				0	0	0	0	<b>Bass steps</b> 15 dB
				0	0	0	1	14 dB
				0	0	1	0	13 dB
				0	0	1	1	12 dB
				0	1	0	0	11 dB
				0	1	0	1	10 dB
				0	1	1	0	9 dB
				0	1	1	1	8 dB
				1	0	0	0	7 dB
				1	0	0	1	6 dB
				1	0	1	0	5 dB
				1	0	1	1	4 dB
				1	1	0	0	3 dB
				1	1	0	1	2 dB
				1	1	1	0	<b>1 dB</b>
				1	1	1	1	0 dB
			0					<b>Mode</b> Cut
			1					<b>Boost</b>
	0	0						<b>Quality Factor</b> 1
	0	1						1.25
	1	0						1.5
	1	1						<b>2</b>
0								<b>DC - Mode</b> Off
1								<b>On</b>

Note 3: For more information please refer to [Section 4.7: Bass](#).

Table 13. Speaker attenuator left front

MSB							LSB		Function
D <sub>7</sub>	D <sub>6</sub>	D <sub>5</sub>	D <sub>4</sub>	D <sub>3</sub>	D <sub>2</sub>	D <sub>1</sub>	D <sub>0</sub>		
		0	0	0	0	0	0	<b>Attenuation</b> 0 dB	
		0	0	0	0	0	1	-1 dB	
		:	:	:	:	:	:	:	
		0	1	0	1	1	1	-23 dB	
		0	1	1	0	0	0	-24.5 dB	
		0	1	1	0	0	1	-26 dB	
		0	1	1	0	1	0	-28 dB	
		0	1	1	0	1	1	-30 dB	
		0	1	1	1	0	0	-32 dB	
		0	1	1	1	0	1	-35 dB	
		0	1	1	1	1	0	-40 dB	
		0	1	1	1	1	1	-50 dB	
		1	X	X	X	X	X	Speaker Mute	
0	0							<b>Bass Center-Frequency</b> 60 Hz	
0	1							80 Hz	
1	0							100 Hz	
1	1							<b>200 Hz</b>	

Table 14. Speaker attenuator right front

MSB							LSB		Function
D <sub>7</sub>	D <sub>6</sub>	D <sub>5</sub>	D <sub>4</sub>	D <sub>3</sub>	D <sub>2</sub>	D <sub>1</sub>	D <sub>0</sub>		
		0	0	0	0	0	0	<b>Attenuation</b> 0 dB	
		0	0	0	0	0	1	-1 dB	
		:	:	:	:	:	:	:	
		0	1	0	1	1	1	-23 dB	
		0	1	1	0	0	0	-24.5 dB	
		0	1	1	0	0	1	-26 dB	
		0	1	1	0	1	0	-28 dB	
		0	1	1	0	1	1	-30 dB	
		0	1	1	1	0	0	-32 dB	
		0	1	1	1	0	1	-35 dB	
		0	1	1	1	1	0	-40 dB	
		0	1	1	1	1	1	-50 dB	
X	X	1	X	X	X	X	X	<b>Speaker Mute</b>	

**Table 15. Speaker attenuator left rear**

MSB							LSB		Function
D <sub>7</sub>	D <sub>6</sub>	D <sub>5</sub>	D <sub>4</sub>	D <sub>3</sub>	D <sub>2</sub>	D <sub>1</sub>	D <sub>0</sub>		
		0	0	0	0	0	0	<b>Attenuation</b> 0 dB	
		0	0	0	0	0	1	-1 dB	
		:	:	:	:	:	:	:	
		0	1	0	1	1	1	-23 dB	
		0	1	1	0	0	0	-24.5 dB	
		0	1	1	0	0	1	-26 dB	
		0	1	1	0	1	0	-28 dB	
		0	1	1	0	1	1	-30 dB	
		0	1	1	1	0	0	-32 dB	
		0	1	1	1	0	1	-35 dB	
		0	1	1	1	1	0	-40 dB	
		0	1	1	1	1	1	-50 dB	
X	X	1	X	X	X	X	X	<b>Speaker mute</b>	

**Table 16. Speaker attenuator right rear**

MSB							LSB		Function
D <sub>7</sub>	D <sub>6</sub>	D <sub>5</sub>	D <sub>4</sub>	D <sub>3</sub>	D <sub>2</sub>	D <sub>1</sub>	D <sub>0</sub>		
		0	0	0	0	0	0	<b>Attenuation</b> 0 dB	
		0	0	0	0	0	1	-1 dB	
		:	:	:	:	:	:	:	
		0	1	0	1	1	1	-23 dB	
		0	1	1	0	0	0	-24.5 dB	
		0	1	1	0	0	1	-26 dB	
		0	1	1	0	1	0	-28 dB	
		0	1	1	0	1	1	-30 dB	
		0	1	1	1	0	0	-32 dB	
		0	1	1	1	0	1	-35 dB	
		0	1	1	1	1	0	-40 dB	
		0	1	1	1	1	1	-50 dB	
X	X	1	X	X	X	X	X	<b>Speaker mute</b>	

**Table 17. Subwoofer attenuator (left and right)**

MSB				LSB				Function
D <sub>7</sub>	D <sub>6</sub>	D <sub>5</sub>	D <sub>4</sub>	D <sub>3</sub>	D <sub>2</sub>	D <sub>1</sub>	D <sub>0</sub>	
		0	0	0	0	0	0	<b>Attenuation</b> 0 dB
		0	0	0	0	0	1	-1 dB
		:	:	:	:	:	:	:
		0	1	0	1	1	1	-23 dB
		0	1	1	0	0	0	-24.5 dB
		0	1	1	0	0	1	-26 dB
		0	1	1	0	1	0	-28 dB
		0	1	1	0	1	1	-30 dB
		0	1	1	1	0	0	-32 dB
		0	1	1	1	0	1	-35 dB
		0	1	1	1	1	0	-40 dB
		0	1	1	1	1	1	-50 dB
X	X	1	X	X	X	X	X	<b>Speaker Mute</b>

**Table 18. Soft-mute and mixing**

MSB				LSB				Function
D <sub>7</sub>	D <sub>6</sub>	D <sub>5</sub>	D <sub>4</sub>	D <sub>3</sub>	D <sub>2</sub>	D <sub>1</sub>	D <sub>0</sub>	
							0	<b>Mute</b> enable soft-mute
							1	disable soft-mute
					0	0		<b>Mute/Zero Cross-Times</b> 0.48 ms
					0	1		0.96 ms
					1	0		30.7 ms / 9 ms
					1	1		122.8 ms / 37 ms
				0				<b>Mixing-Source</b> Beep
				1				Phone
		0	0					<b>Mixing-Level (Main / Mix-Source)</b> -12 / -2.5 dB
		0	1					-6 / -6 dB
		1	0					-3.5 / -9.6 dB
		1	1					0 / ∞
0	0							<b>Beep Frequency</b> 781 Hz
0	1							1.56 kHz
1	0							Not allow
1	1							<b>1.8 kHz</b>

**Table 19. Others**

MSB							LSB		Function
D <sub>7</sub>	D <sub>6</sub>	D <sub>5</sub>	D <sub>4</sub>	D <sub>3</sub>	D <sub>2</sub>	D <sub>1</sub>	D <sub>0</sub>		
						X 0 1	0 1 1	<b>AC coupling</b> Internal pass Coupling between Mixing Stage and Volume Coupling between Bass filter and Speaker attenuator	
				1	1			Must be "1" for make up Must be "1" for make up	
		0 0 1 1	0 1 0 1					<b>Soft Step Time</b> 0.68ms 1.26ms 2.52ms 5.04ms	
	1							Must be "1" for AutoZero	
0 1								<b>Internal Beep</b> Off ON	

**Table 20. Testing**

MSB							LSB		Function
D <sub>7</sub>	D <sub>6</sub>	D <sub>5</sub>	D <sub>4</sub>	D <sub>3</sub>	D <sub>2</sub>	D <sub>1</sub>	D <sub>0</sub>		
		X X	X X	X X			0 1	<b>Main-Testmode</b> off on	
		X X	X X	X X		0 1		<b>Test-Multiplexer</b> internal 200kHz Clock internal Bandgap Voltage	
		X X	X X	X X	0 1			<b>Clock</b> external internal	
1	1							must be "1"	

# 6 Application circuit

Figure 18. TDA7404 application circuit

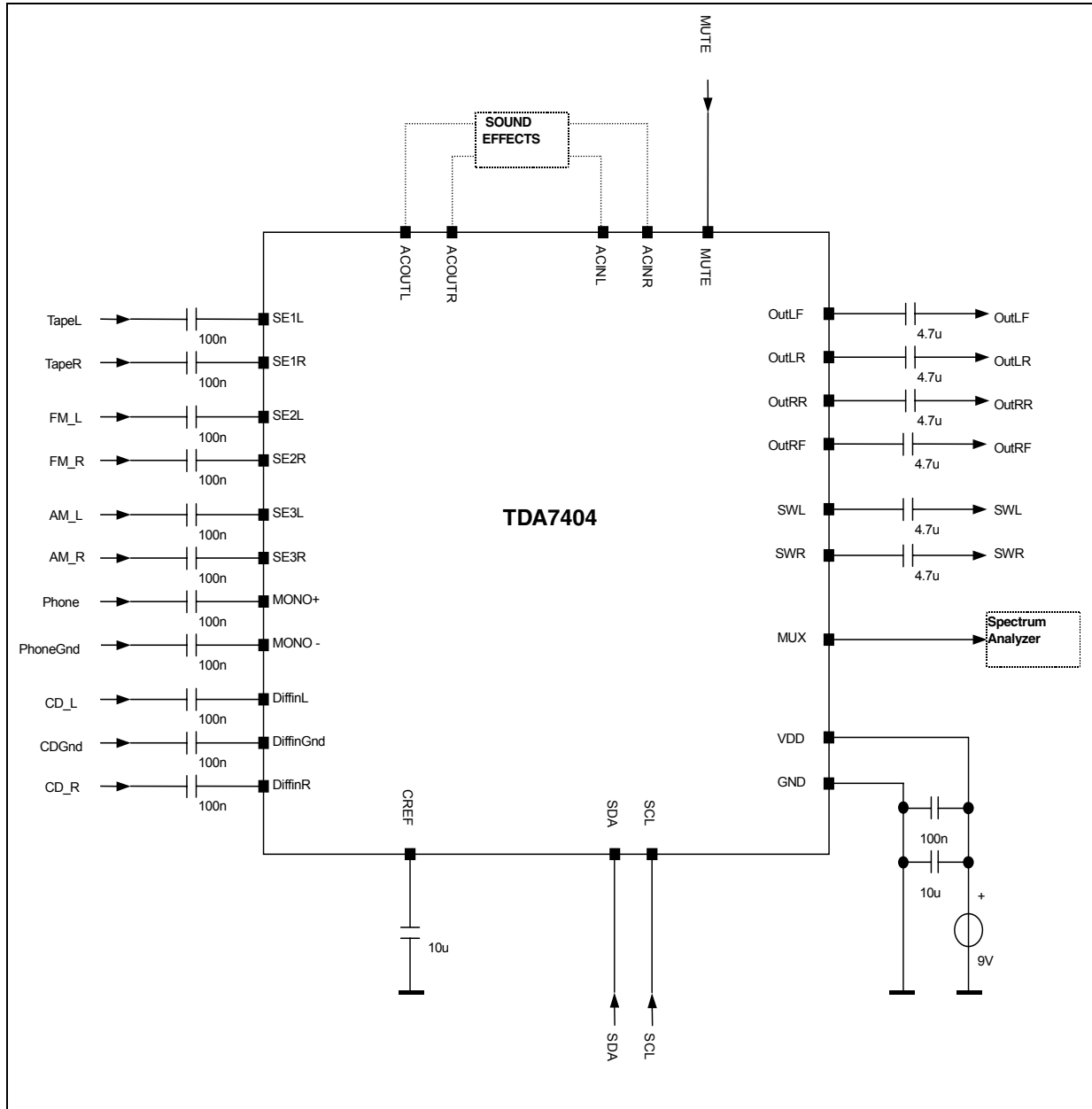



# 7 Package information

In order to meet environmental requirements, ST offers these devices in different grades of ECOPACK® packages, depending on their level of environmental compliance. ECOPACK® specifications, grade definitions and product status are available at: [www.st.com](http://www.st.com).

ECOPACK® is an ST trademark.

**Figure 19. SO-28 mechanical data and package dimensions**

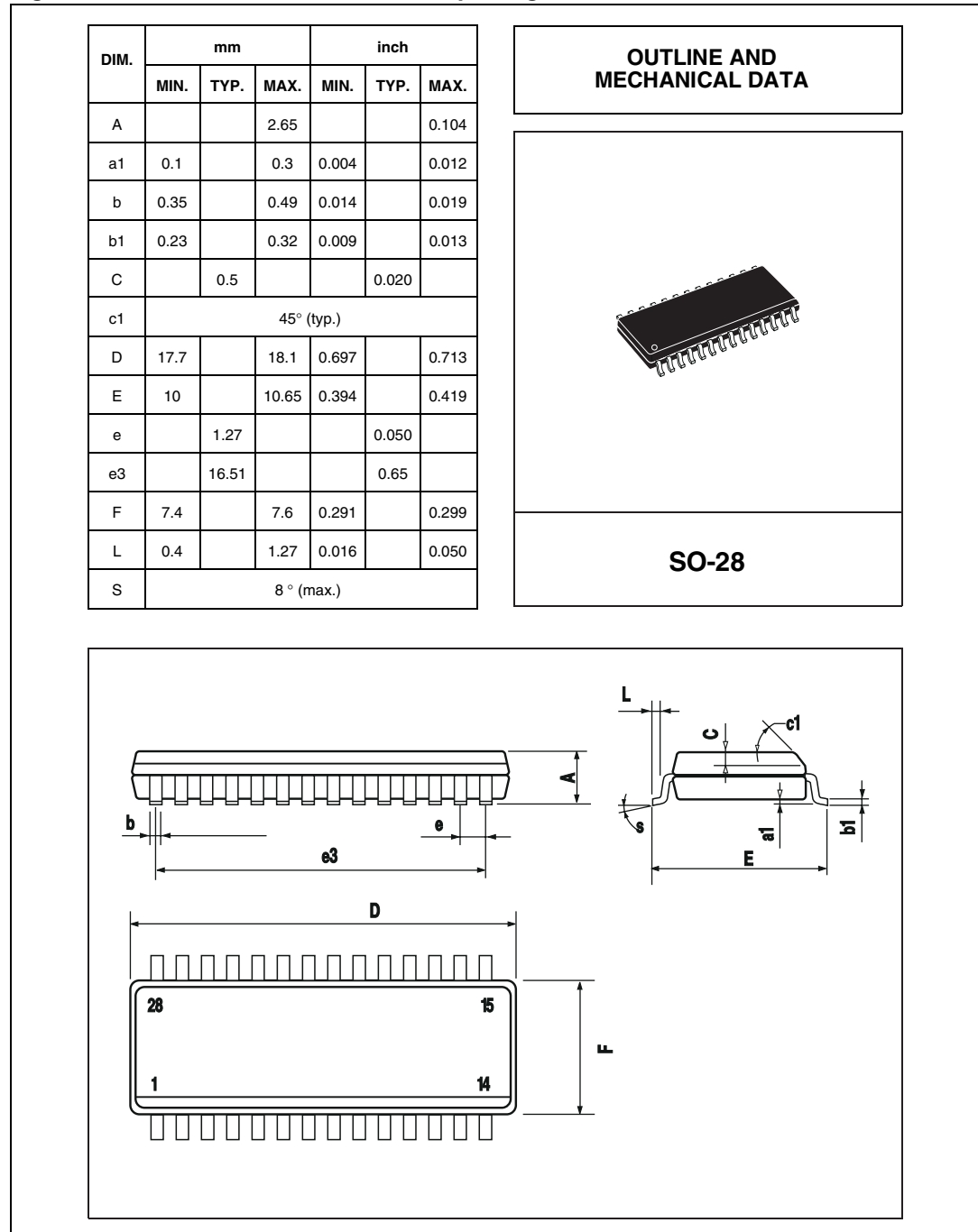

## 8 Revision history

**Table 21. Document revision history**

Date	Revision	Changes
15-Jul-2003	1	Initial release.
16-Dec-2008		Document reformatted. Added <a href="#">Table 1: Device summary on page 1</a> . Updated <a href="#">Section 7: Package information</a> .

**Please Read Carefully:**

Information in this document is provided solely in connection with ST products. STMicroelectronics NV and its subsidiaries ("ST") reserve the right to make changes, corrections, modifications or improvements, to this document, and the products and services described herein at any time, without notice.

All ST products are sold pursuant to ST's terms and conditions of sale.

Purchasers are solely responsible for the choice, selection and use of the ST products and services described herein, and ST assumes no liability whatsoever relating to the choice, selection or use of the ST products and services described herein.

No license, express or implied, by estoppel or otherwise, to any intellectual property rights is granted under this document. If any part of this document refers to any third party products or services it shall not be deemed a license grant by ST for the use of such third party products or services, or any intellectual property contained therein or considered as a warranty covering the use in any manner whatsoever of such third party products or services or any intellectual property contained therein.

**UNLESS OTHERWISE SET FORTH IN ST'S TERMS AND CONDITIONS OF SALE ST DISCLAIMS ANY EXPRESS OR IMPLIED WARRANTY WITH RESPECT TO THE USE AND/OR SALE OF ST PRODUCTS INCLUDING WITHOUT LIMITATION IMPLIED WARRANTIES OF MERCHANTABILITY, FITNESS FOR A PARTICULAR PURPOSE (AND THEIR EQUIVALENTS UNDER THE LAWS OF ANY JURISDICTION), OR INFRINGEMENT OF ANY PATENT, COPYRIGHT OR OTHER INTELLECTUAL PROPERTY RIGHT.**

**UNLESS EXPRESSLY APPROVED IN WRITING BY AN AUTHORIZED ST REPRESENTATIVE, ST PRODUCTS ARE NOT RECOMMENDED, AUTHORIZED OR WARRANTED FOR USE IN MILITARY, AIR CRAFT, SPACE, LIFE SAVING, OR LIFE SUSTAINING APPLICATIONS, NOR IN PRODUCTS OR SYSTEMS WHERE FAILURE OR MALFUNCTION MAY RESULT IN PERSONAL INJURY, DEATH, OR SEVERE PROPERTY OR ENVIRONMENTAL DAMAGE. ST PRODUCTS WHICH ARE NOT SPECIFIED AS "AUTOMOTIVE GRADE" MAY ONLY BE USED IN AUTOMOTIVE APPLICATIONS AT USER'S OWN RISK.**

Resale of ST products with provisions different from the statements and/or technical features set forth in this document shall immediately void any warranty granted by ST for the ST product or service described herein and shall not create or extend in any manner whatsoever, any liability of ST.

ST and the ST logo are trademarks or registered trademarks of ST in various countries.

Information in this document supersedes and replaces all information previously supplied.

The ST logo is a registered trademark of STMicroelectronics. All other names are the property of their respective owners.

© 2008 STMicroelectronics - All rights reserved

STMicroelectronics group of companies

Australia - Belgium - Brazil - Canada - China - Czech Republic - Finland - France - Germany - Hong Kong - India - Israel - Italy - Japan - Malaysia - Malta - Morocco - Singapore - Spain - Sweden - Switzerland - United Kingdom - United States of America

[www.st.com](http://www.st.com)