



TDA7360

Preliminary

CMOS IC

20W BRIDGE/STEREO AUDIO AMPLIFIER WITH CLIPPING DETECTOR

DESCRIPTION

The UTC **TDA7360** is a new technology class AB Audio Power Amplifier in the Multiwatt® package. The high power performance of the UTC **TDA7360** is obtained without bootstrap capacitors due to the fully complementary PNP/NPN output configuration

The audible on/off noise is eliminated by a delayed turn-on mute circuit, and a novel short circuit protection system prevents spurious intervention.

The device provides a circuit for the detection of clipping in the output stages. An open collector output is able to drive systems with automatic volume control.

FEATURES

- * Very few external components
- * Without boucherot cells
- * Without bootstrap capacitors
- * High output power
- * Very low STAND-BY current
- * Fixed gain (20dB stereo)
- * Programmable turn-on delay
- * Clipping detector
- * No switch on/off noise
- * STAND-BY function

ORDERING INFORMATION

Ordering Number		Package	Packing
Lead Free	Halogen Free		
TDA7360L-J11-T	TDA7360G-J11-T	HZIP-11A	Tube
TDA7360L-J15 -T	TDA7360G-J15-T	HZIP-15A	Tube

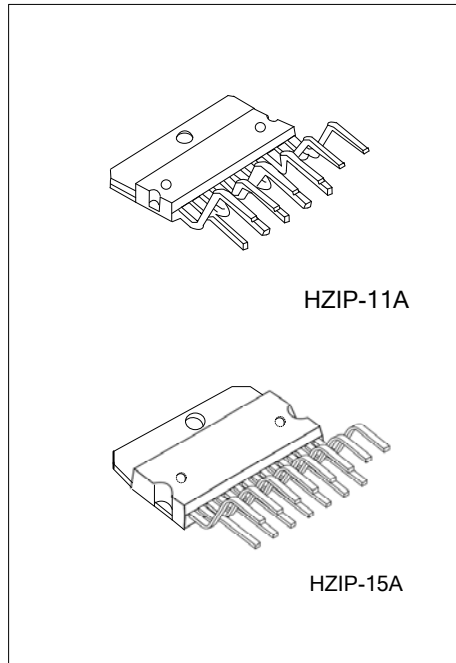

<p>TDA7360L-J11-A-T</p> <p>(1)Packing Type (2)Package Type (3)Green Package</p>	<p>(1) T: Tube (2) J11-A: HZIP-11A, J15: HZIP-15A (3) L: Lead Free, G: Halogen Free and Lead Free</p>
---	---

MARKIN

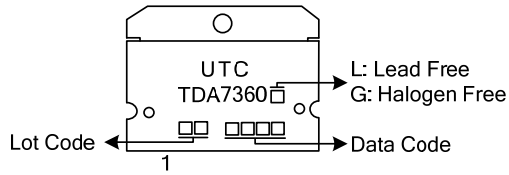

PIN CONFIGURATION

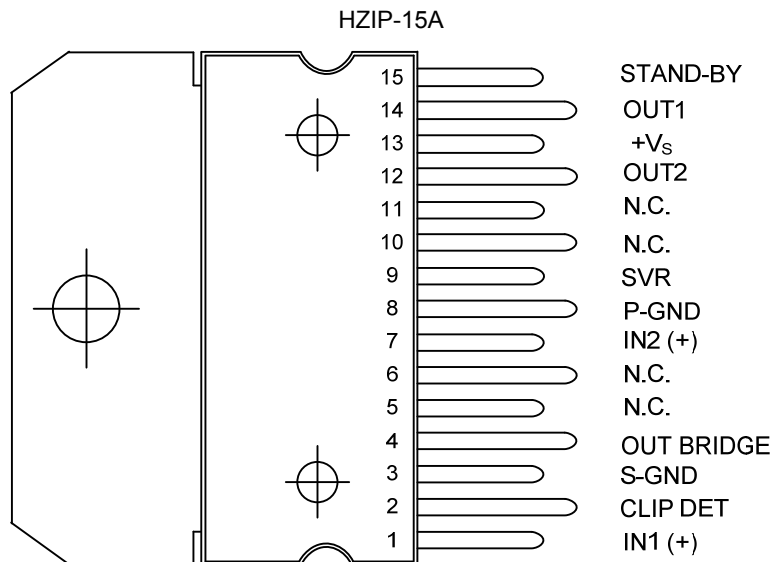
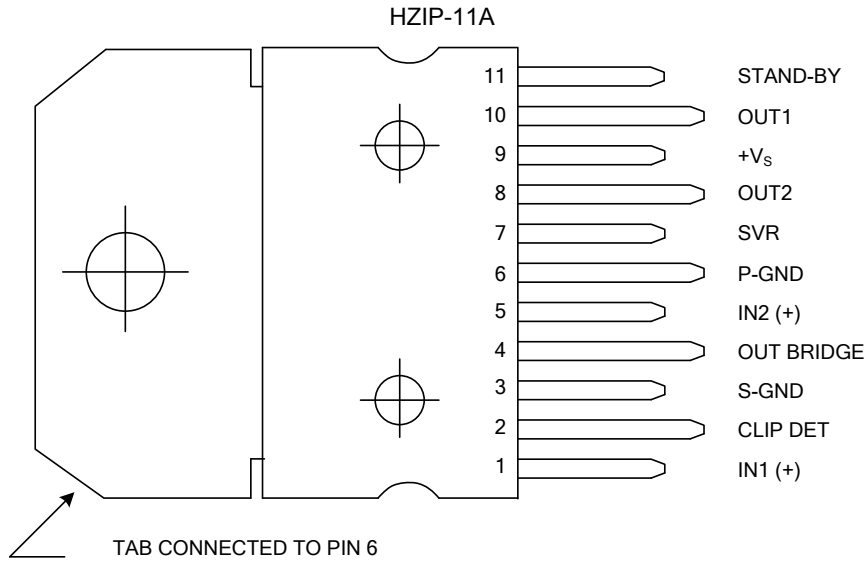

■ PIN DESCRIPTION

PIN NO.		PIN NAME	DESCRIPTION
HZIP-11A	HZIP-15A		
1	1	IN1 (+)	Amp IN1 (+)
2	2	CLIP DET	Clip detector
3	3	S-GND	Signal Ground
4	4	OUT BRIDGE	Bridge output
5	7	IN2 (+)	Amp IN2 (+)
6	8	P-GND	Power Ground
7	9	SVR	Supply voltage rejection
8	12	OUT2	Output2
9	13	+V _S	Supply voltage
10	14	OUT1	Output1
11	15	STAND-BY	Stand-by
-	5, 6, 10, 11	N.C.	

■ BLOCK DIAGRAM

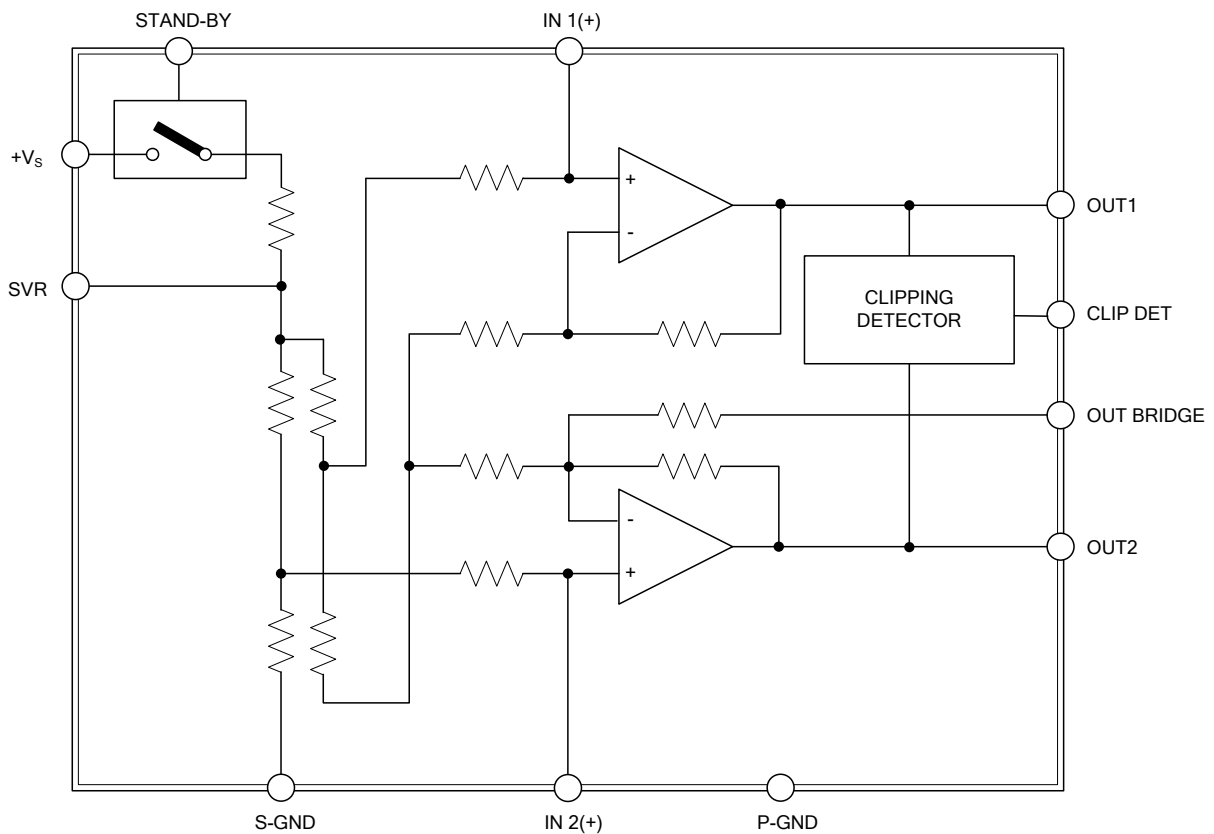

■ ABSOLUTE MAXIMUM RATING

PARAMETER	SYMBOL	RATINGS	UNIT
Operating Supply Voltage	V_S	22	V
Output Peak Current (non rep. for $t=100\mu s$)	I_o	5	A
Output Peak Current (rep. freq. $>10Hz$)	I_o	4	A
Power Dissipation At $T_{CASE}=85^\circ C$	P_D	36	W
Storage And Junction Temperature	T_{STG}, T_J	-40 ~ +150	$^\circ C$

Note: Absolute maximum ratings are those values beyond which the device could be permanently damaged. Absolute maximum ratings are stress ratings only and functional device operation is not implied.

■ THERMAL DATA

PARAMETER	SYMBOL	RATINGS	UNIT
Thermal Resistance Junction-case Max	$R_{THJ-CASE}$	1.8	$^\circ C/W$

■ ELECTRICAL CHARACTERISTICS

(Refer to the test circuits, $T_{AMB}=25^\circ C$, $V_S=14.4V$, $f=1KHz$ unless otherwise specified)

PARAMETER	SYMBOL	TEST CONDITIONS	MIN	TYP	MAX	UNIT	
Supply Voltage Range	V_S		8		18	V	
Total Quiescent Drain Current	I_D	stereo configuration		65	120	mA	
Stand-by Attenuation	A_{SB}		60	80		dB	
Stand-by Current	I_{SB}				100	μA	
Standby ON Threshold	V_{ST_ON}				1	V	
Standby OFF Threshold	V_{ST_OFF}		3.5			V	
Clip Detector Prog. Current	I_{CO}	pin 2 pull up to 5V $d=1\%$ with 10KW $d=5\%$		70 130		μA	
STEREO							
Output Power (each channel) THD=10%	P_o	$R_L=2\Omega$		11		W	
		$R_L=3.2\Omega$	7	8			
		$V_{CC}=12V, R_L=4\Omega$		4.5			
		$R_L=4\Omega$		6.5			
Distortion	D	$P_o=0.1\sim 2.5W, R_L=4\Omega$		0.05	0.5	%	
		$P_o=0.1\sim 4W, R_L=3.2\Omega$		0.05	0.5		
Supply Voltage Rejection	SVR	$R_g=10K\Omega, C_3=22\mu F$ $f=100Hz, C_3=100\mu F$	45	62		dB	
Crosstalk	CT	$f=1KHz$ $f=10KHz$	45	55		dB	
Input Resistance	R_i			50		K Ω	
Voltage Gain	G_v		19	20	21	dB	
Voltage Gain Match	G_v				1	dB	
Input Noise Voltage	E_{IN}	22Hz~22KHz	$R_g=50\Omega$		2.5	5	μV
			$R_g=10K\Omega$		3	7	
			$R_g=\infty$		3.5		
BRIDGE							
Output Offset Voltage	V_{OS}				250	mV	
Output Power THD=10%	P_o	$V_{CC}=12V, R_L=4\Omega$		15		W	
		$V_{CC}=14.4V, R_L=4\Omega$	16	20			
Distortion	d	$P_o=0.1\sim 7W, R_L=4\Omega$		0.05	0.5	%	
Supply Voltage Rejection	SVR	$R_g=10K\Omega, C_3=22\mu F$ $f=100Hz, C_3=100\mu F$	45	62		dB	
Input Resistance	R_i			50		K Ω	
Voltage Gain	G_v			26		dB	
Input Noise Voltage	EIN	22Hz~22KHz	$R_g=50\Omega$		3.5	μV	
			$R_g=10K\Omega$		4	μV	

BRIDGE APPLICATION CIRCUIT

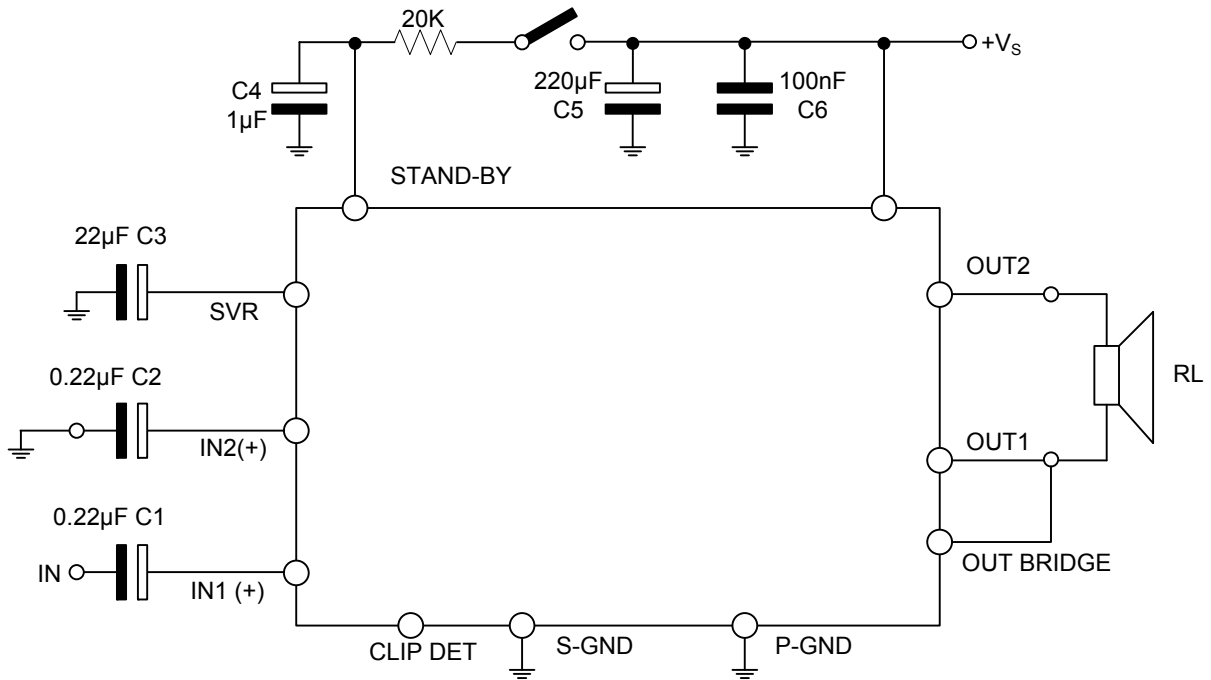

STEREO APPLICATION CIRCUIT

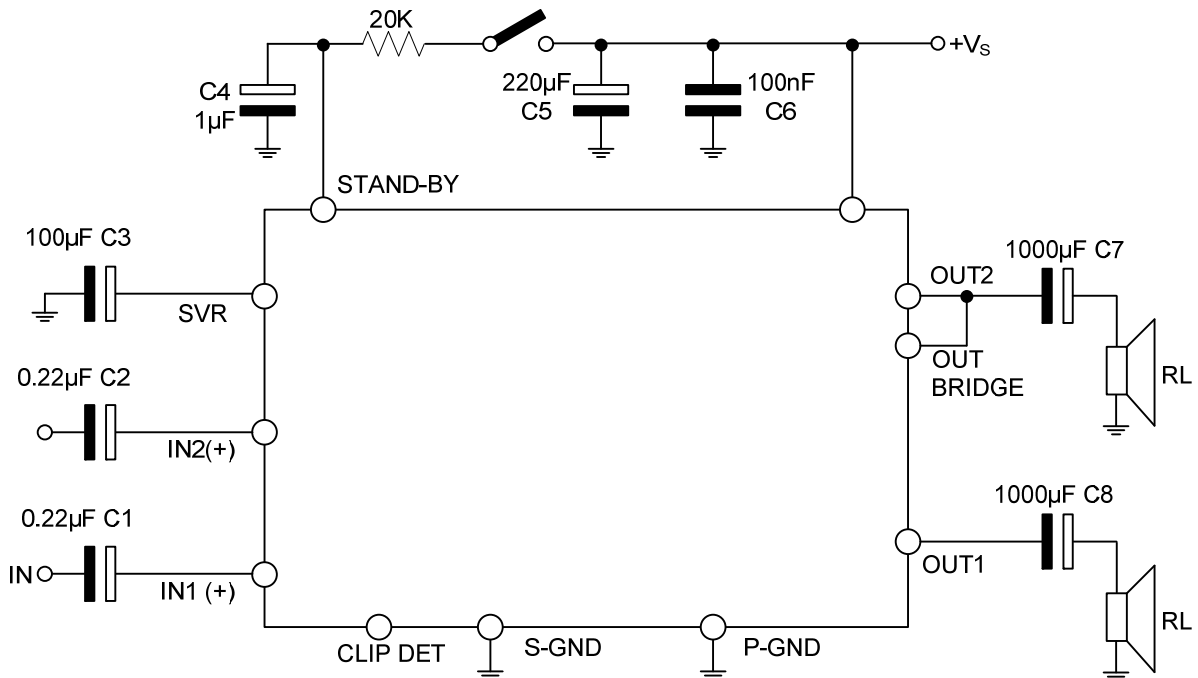

UTC assumes no responsibility for equipment failures that result from using products at values that exceed, even momentarily, rated values (such as maximum ratings, operating condition ranges, or other parameters) listed in products specifications of any and all UTC products described or contained herein. UTC products are not designed for use in life support appliances, devices or systems where malfunction of these products can be reasonably expected to result in personal injury. Reproduction in whole or in part is prohibited without the prior written consent of the copyright owner. The information presented in this document does not form part of any quotation or contract, is believed to be accurate and reliable and may be changed without notice.