



SINGLE CHIP RDS DEMODULATOR + FILTER

- HIGH PERFORMANCE, 57KHz BANDPASS FILTER (8th ORDER)
- FILTER ADJUSTMENT FREE AND WITHOUT EXTERNAL COMPONENTS
- PURELY DIGITAL RDS DEMODULATION WITHOUT EXTERNAL COMPONENTS
- ARI (SK INDICATION) AND RDS SIGNAL QUALITY OUTPUT
- 4.332MHz CRYSTAL OSCILLATOR (8.664MHz OPTIONAL)
- LOW NOISE MIXED BIPOLAR/CMOS TECHNOLOGY

DESCRIPTION

The TDA7330B is a RDS demodulator. It recovers the additional inaudible RDS information which is transmitted by FM radio broadcasting stations.

The output data signal (RDDA) and clock signal (RDCL) can be further processed by a suitable RDS decoder (microprocessor).

The device operates in accordance with the EBU (European Broadcasting Union) specifications.

The IC includes a 2nd order antialiasing input fil-

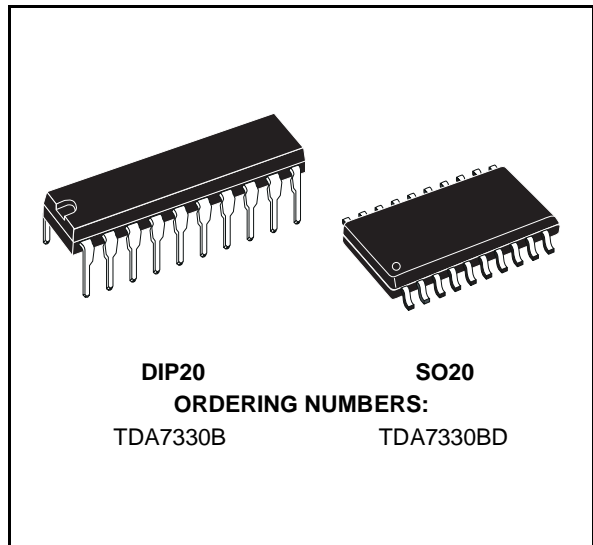

ter, a 57KHz switched capacitor band pass filter, a smoothing filter and cross detector, a bit rate clock recovery circuit, a 57KHz PLL, BI-PHASE PSK decoder, differential decoding circuit, ARI indication and RDS signal quality output.

BLOCK DIAGRAM

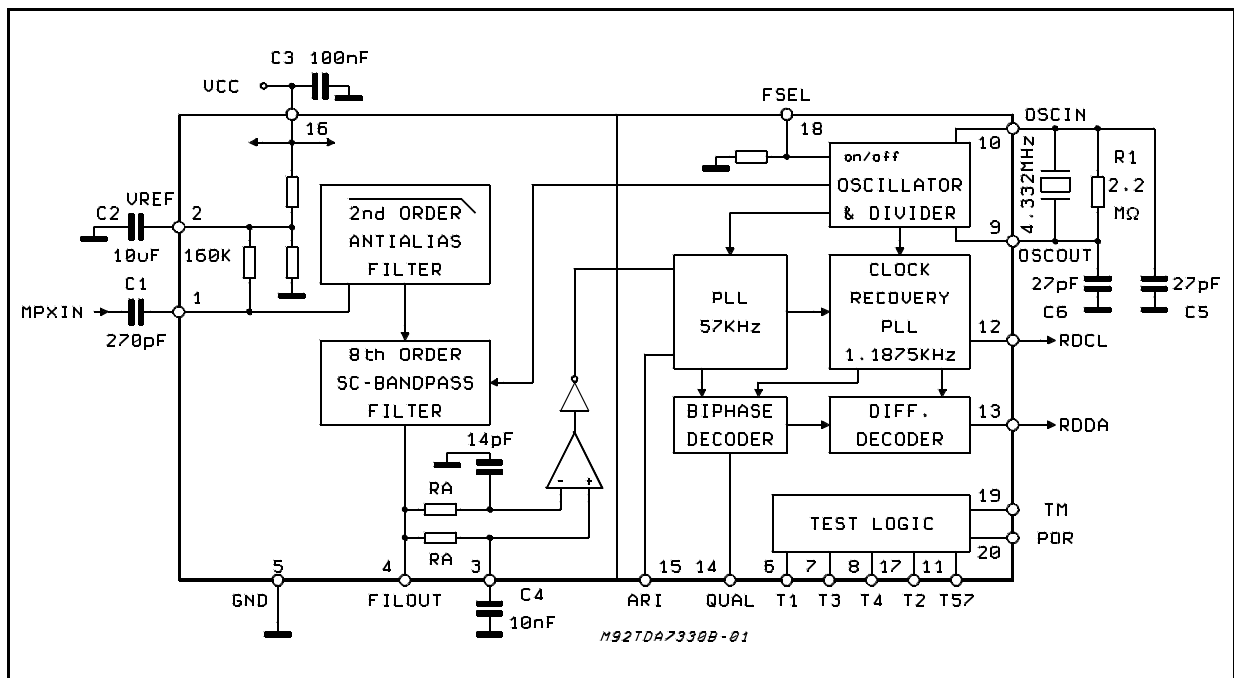

TDA7330B

ABSOLUTE MAXIMUM RATINGS

Symbol	Parameter	Value	Unit
V _{CC}	Supply Voltage	7	V
T _{op}	Operating Temperature Range	-40 to 85	°C
T _{stg}	Storage Temperature	-40 to 150	°C

THERMAL DATA

Symbol	Description	DIP20	SO20	Unit
R _{th j-case}	Thermal Resistance Junction-case	Typ. 100	200	°C/W

PIN CONNECTION (Top view)

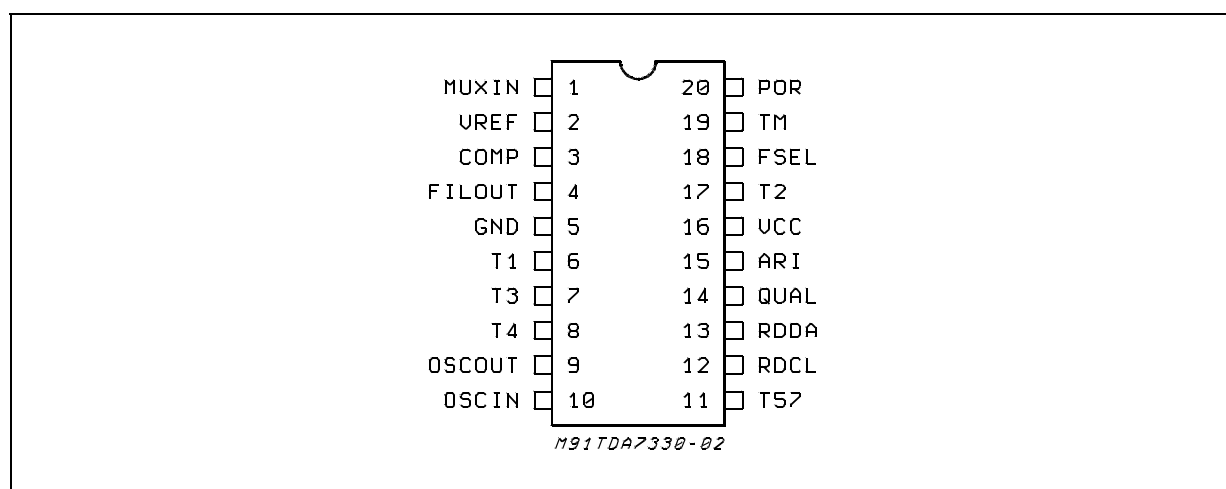

PIN FUNCTION

Nr.	Name	Description
1	MUXIN	RDS input signal.
2	V _{ref}	Reference voltage
3	COMP	Not inverting comparator input (smoothing filter)
4	FIL OUT	Filter Output
5	GND	Ground
6	T1	Testing output pin (not to be used)
7	T3	Testing output pin (not to be used)
8	T4	Testing output pin (not to be used)
9	OSC OUT	Oscillator output
10	OSC IN	Oscillator Input
11	T57	Testing output pin: 57KHz clock output
12	RDCL	RDS clock output (1187.5Hz)
13	RDDA	RDS data output
14	QUAL	Output for signal quality indication (High = good)
15	ARI	Output for ARI indication (High when RDS + ARI signals are present) (High when only ARI is present) (Low when only RDS is present) (undefined when no signal is present)
16	V _{CC}	Supply Voltage
17	T2	Testing output pin (not to be used)
18	FSEL	Frequency selector pin: open = 4.332MHz, closed to V _{CC} = 8.664MHz
19	TM	Test mode pin (open = normal RUN) (closed to V _{CC} = Test mode)
20	POR	Reset Input for testing (active high)

ELECTRICAL CHARACTERISTICS ($V_{CC} = 5V$, $T_{amb} = 25^{\circ}C$; $R_g = 600\Omega$; $f_{osc} = 4.332MHz$; $V_{IN} = 20mV_{rms}$ unless otherwise specified)

Symbol	Parameter	Test Condition	Min.	Typ.	Max.	Unit
--------	-----------	----------------	------	------	------	------

SUPPLY

V_{CC}	Supply Voltage		4.5	5	5.5	V
I_S	Supply Current			9		mA
R_{POR}	POR Pull Down Resistor	pin 20		40		K Ω
POR_{ON}	POR Threshold			2.5		V

FILTER(measured an pin 4 FILOUT)

F_C	Center Frequency		56.5	57	57.5	KHz
BW	3dB Bandwidth		2.5	3	3.5	KHz
G	Gain	$f = 57KHz$	18	20	22	dB
A	Attenuation	$\Delta f = \pm 4KHz$ $f = 38KHz$; $V_i = 500mV_{rms}$ $f = 67KHz$; $V_i = 250mV_{rms}$	18 50 35	22 80 50		dB dB dB
ΔPh	Phase non linearity	A (see note1) B (see note1) C (see note1)		0.5 1 2	5 7.5 10	DEG DEG DEG
R_i	Input Impedance		100	160	200	K Ω
S/N	Signal to Noise Ratio	$V_i = 3mV_{rms}$	30	40		dB
V_i	Maximum Input Signal Capability	$f = 19KHz$; $T_3 \leq -40dB$ (see note2) $f = 57KHz$ (RDS + ARI)			1 50	V $_{rms}$ mV $_{rms}$
R_L	Load Impedance	Pin 4	100			K Ω

CROSS DETECTOR

RA	Resistance pin 3-4		15	21	28	K Ω
----	--------------------	--	----	----	----	------------

OSCILLATOR

F_{OSC}	Oscillator Frequency	$F_{SEL} = \text{Open (*)}$ $F_{SEL} = \text{Closed to } V_{CC} (**)$		4.332 8.664		MHz MHz
VCLL	Clock Input level LOW (pin 10)				1	V
VCLH	Clock Input Level HIGH (pin 10)		4			V
	Output Amplitude (pin 9)			4.5		V $_{PP}$

(*) FSEL pin has an internal 40K Ω pull down resistor A 4.332MHz QUARTZ must be used (**) A 8.664MHz QUARTZ must be used.

DEMODULATOR

Δf_0	Max Oscillator Deviation	$F_{SEL} = \text{Open}$		± 1.2		KHz
S_{RDS}	RDS Detection Sensitivity		1			mV $_{rms}$
S_{ARI}	ARI Detection Sensitivity		3			mV $_{rms}$
T_{lock}	RDS Lockup Time			100		ms
V_{OH}	Output HIGH Voltage	$I_L = 0.5mA$; pins 12, 13, 14, 15	4			V
V_{OL}	Output LOW Voltage	$I_L = 0.5mA$; pins 12, 13, 14, 15			1	V
f_{RDS}	Data Rate for RDS	RDCL pin		1187.5		Hz
t_D	RDDA Transition versus RDCL	(see figure 2)		4.3		μsec

Note(1):

The phase non linearity is defined as: $\Delta Ph = | -2 \phi f_2 + \phi f_1 + \phi f_3 |$
where ϕf_x is the input-output phase difference at the frequency f_x ($x = 1,2,3$)

TDA7330B

ELECTRICAL CHARACTERISTICS (continued)

Measure	f1 (KHz)	f2 (KHz)	f3 (KHz)	ΔPh max
A	56.5	57	57.5	<5°
B	56	57	58	<7.5°
C	55.5	57	58.5	<10°

Note(2): The 3th harmonic (57KHz) must be less than -40dB in respect to the input signal 19KHz plus gain.

Figure 2: RDS timing diagram

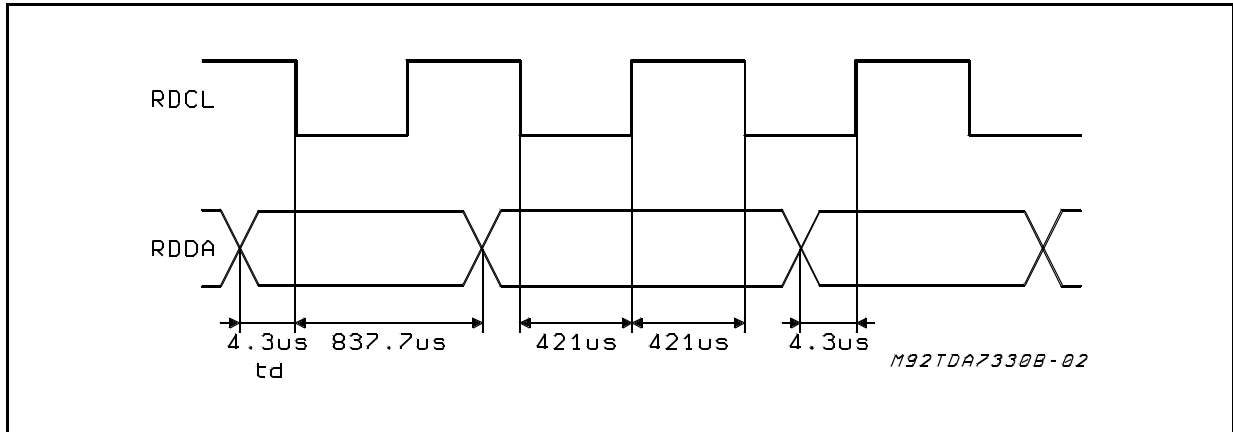

OUTPUT TIMING

The generated 1187.5Hz output clock (RDCL line) is synchronized to the incoming data. According to the internal PLL lock condition this

data change can results on the falling or on the rising clock edge. Whichever clock edge is used by the decoder (rising or falling edge) the data will remain valid for 416.7 µsec after the clock transition.

Figure 3: Test Circuit

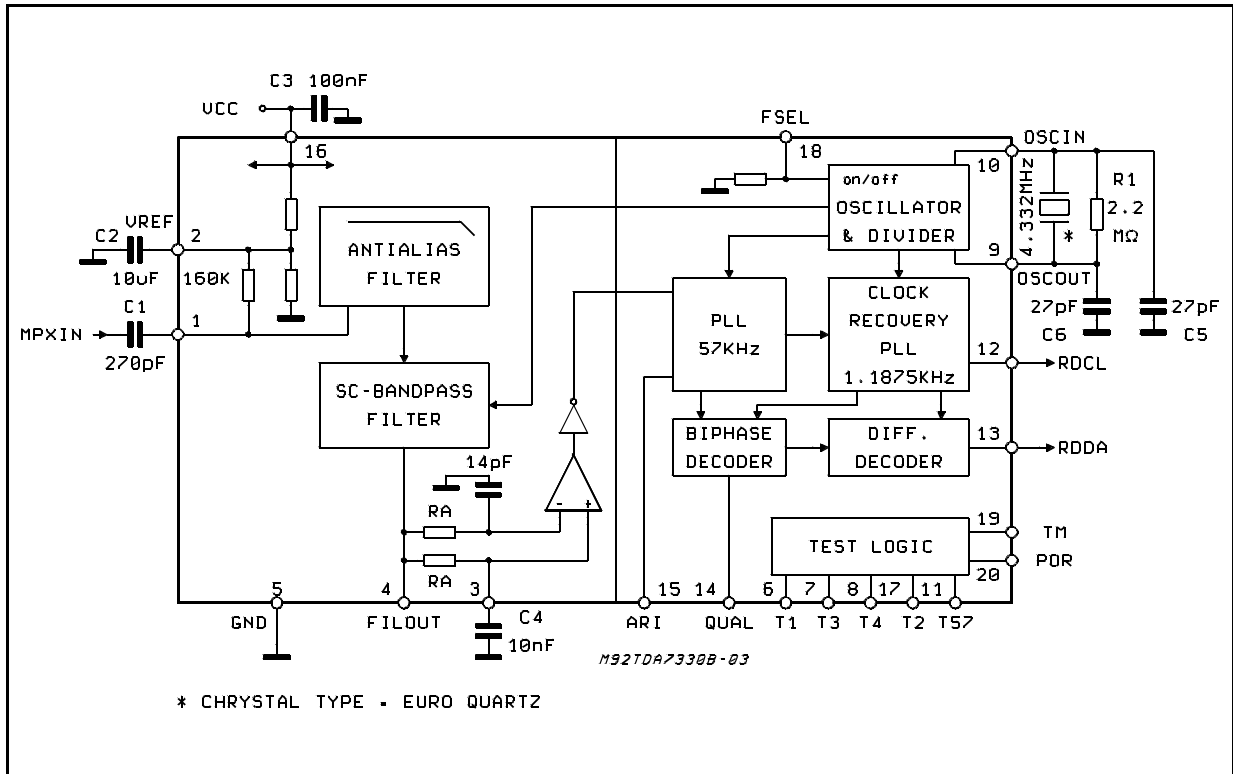

APPLICATION SUGGESTION

- A good DC decoupling between V_{CC} and GROUND is necessary: a 100nF ceramic capacitor, with low resistance and low inductance at high frequency, directly connected on pin 16 (V_{CC}) and 5 (GND) is recommended.
- A small series inductance (100 μ H) or resistor (27 Ω) may be used for supply line filtering.
- The Layout path pin2 - C2 - pin5 must be as short as possible.
- If the supply line, after the power on has a soft and disturbed (spikes) slope, a capacitor of 100nF, between POR and V_{CC} , is recommended.
- The various testing pins have no sense for the customer.

Figure 4: P.C. board and component layout of fig. 3 (1:1 scale)

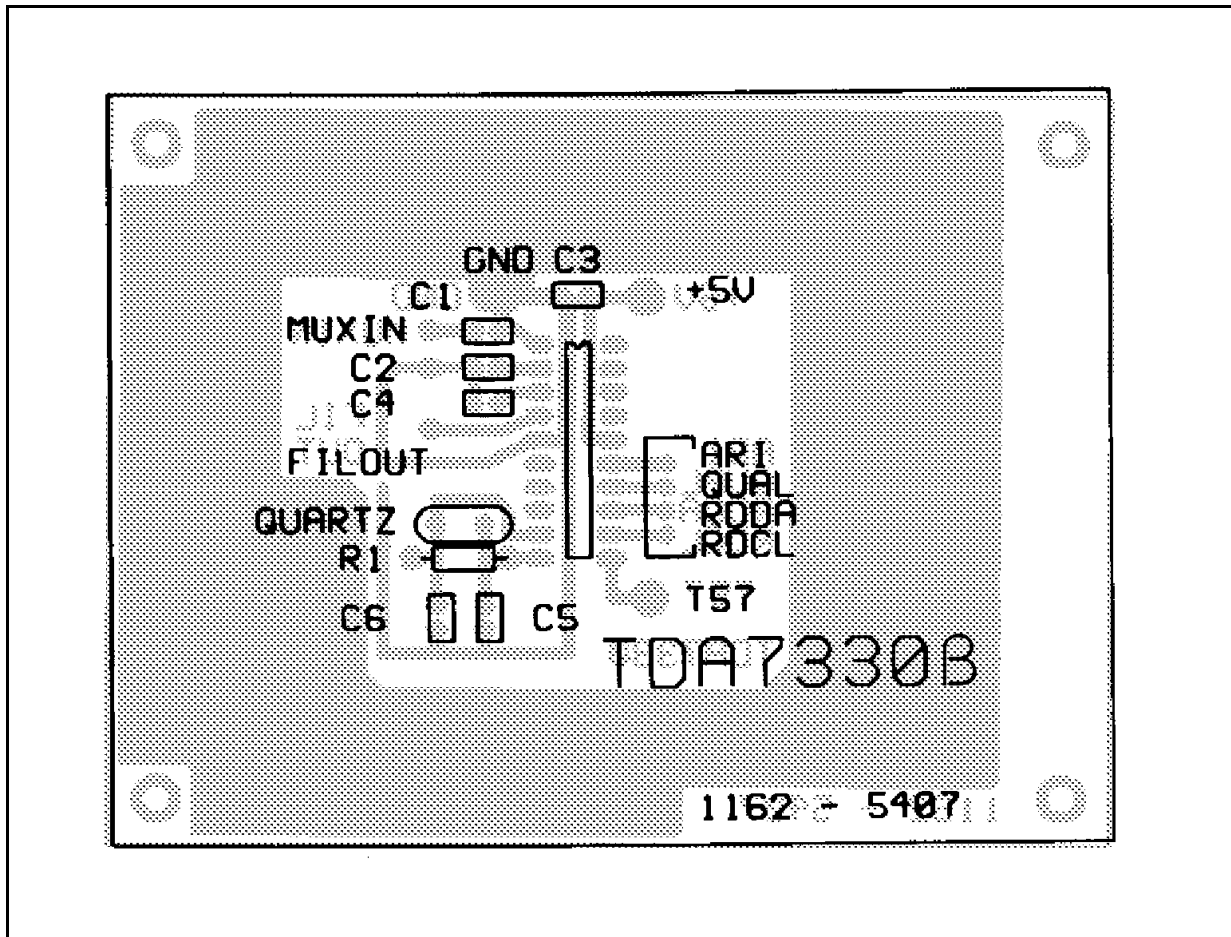

Figure 5: Gain vs. Frequency

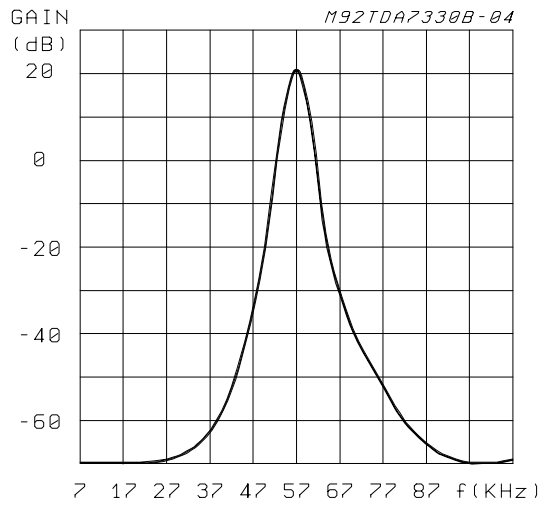
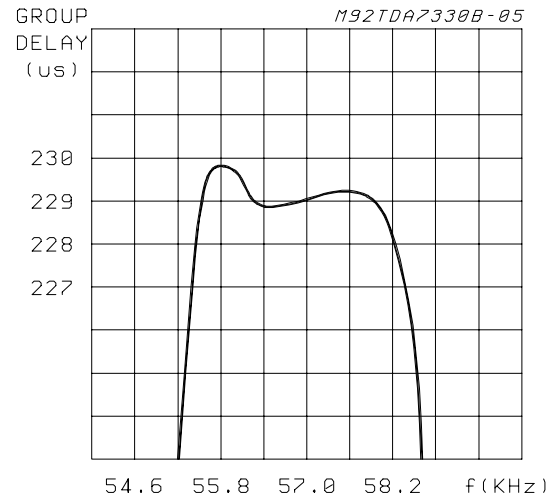
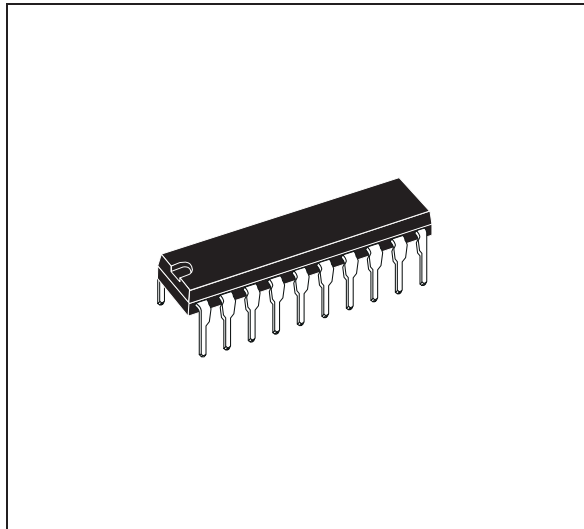

Figure 6: Group Delay vs. Frequency



DIM.	mm			inch		
	MIN.	TYP.	MAX.	MIN.	TYP.	MAX.
a1	0.254			0.010		
B	1.39		1.65	0.055		0.065
b		0.45			0.018	
b1		0.25			0.010	
D			25.4			1.000
E		8.5			0.335	
e		2.54			0.100	
e3		22.86			0.900	
F			7.1			0.280
I			3.93			0.155
L		3.3			0.130	
Z			1.34			0.053

OUTLINE AND MECHANICAL DATA



DIP20

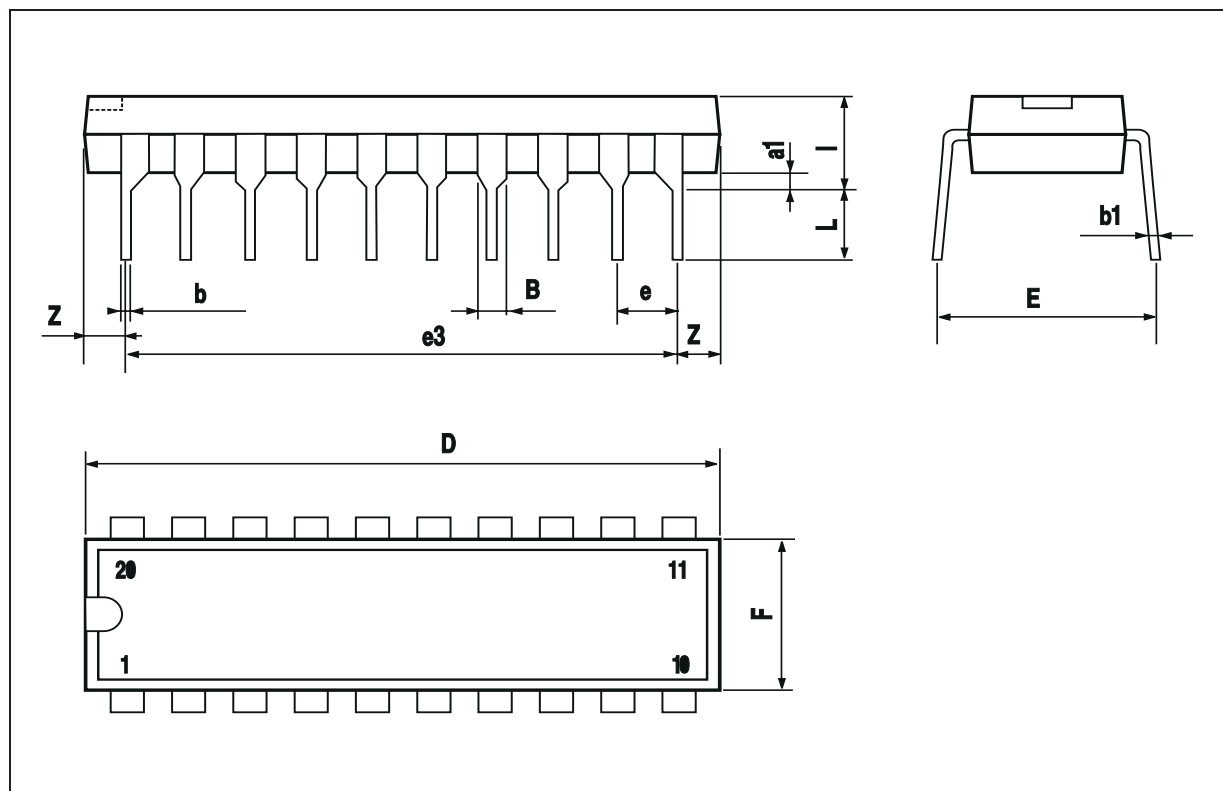

DIM.	mm			inch		
	MIN.	TYP.	MAX.	MIN.	TYP.	MAX.
A	2.35		2.65	0.093		0.104
A1	0.1		0.3	0.004		0.012
B	0.33		0.51	0.013		0.020
C	0.23		0.32	0.009		0.013
D	12.6		13	0.496		0.512
E	7.4		7.6	0.291		0.299
e		1.27			0.050	
H	10		10.65	0.394		0.419
h	0.25		0.75	0.010		0.030
L	0.4		1.27	0.016		0.050
K	0° (min.)8° (max.)					

OUTLINE AND MECHANICAL DATA

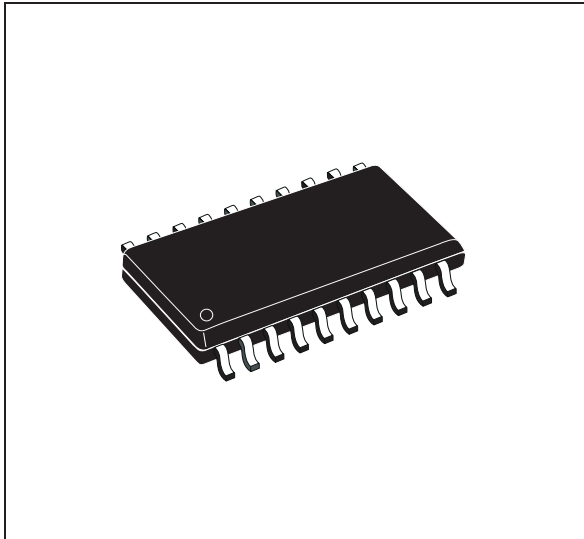

SO20

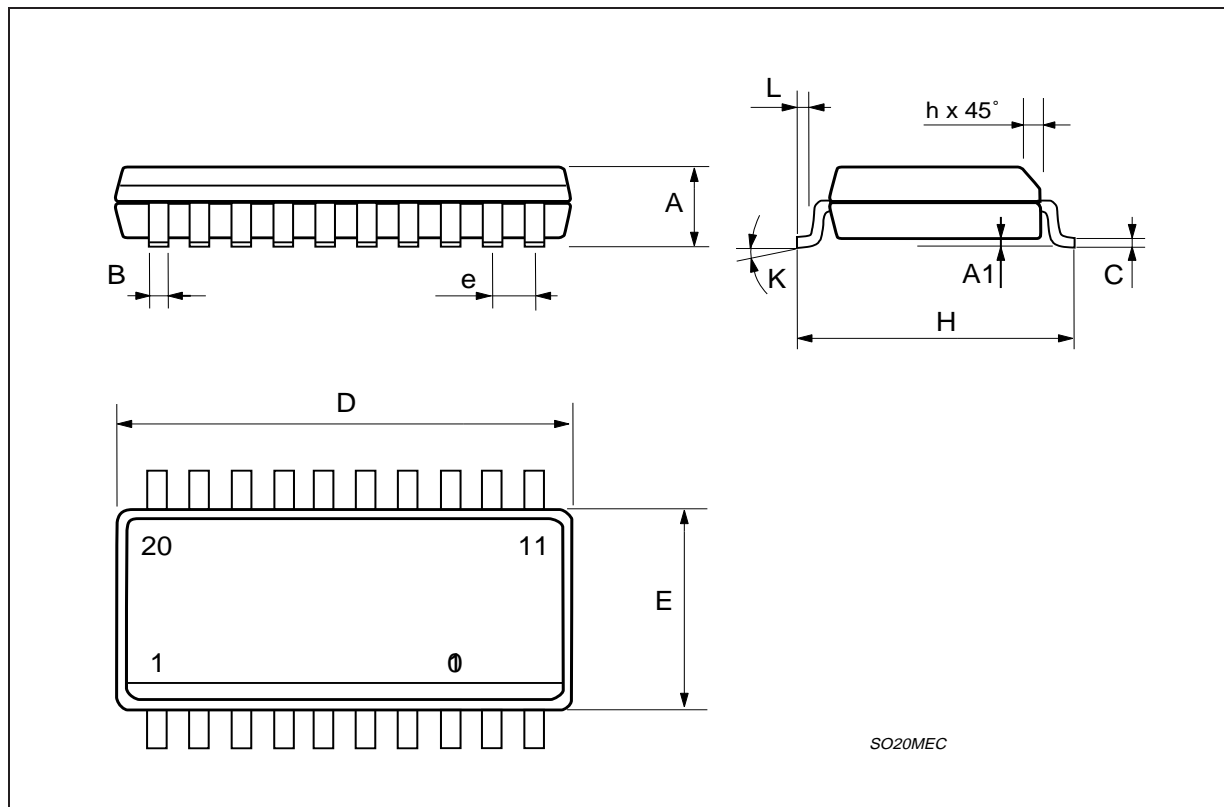

SO20MEC

Information furnished is believed to be accurate and reliable. However, STMicroelectronics assumes no responsibility for the consequences of use of such information nor for any infringement of patents or other rights of third parties which may result from its use. No license is granted by implication or otherwise under any patent or patent rights of STMicroelectronics. Specification mentioned in this publication are subject to change without notice. This publication supersedes and replaces all information previously supplied. STMicroelectronics products are not authorized for use as critical components in life support devices or systems without express written approval of STMicroelectronics.

The ST logo is a registered trademark of STMicroelectronics

© 1999 STMicroelectronics – Printed in Italy – All Rights Reserved

STMicroelectronics GROUP OF COMPANIES

Australia - Brazil - China - Finland - France - Germany - Hong Kong - India - Italy - Japan - Malaysia - Malta - Morocco -
Singapore - Spain - Sweden - Switzerland - United Kingdom - U.S.A.

<http://www.st.com>