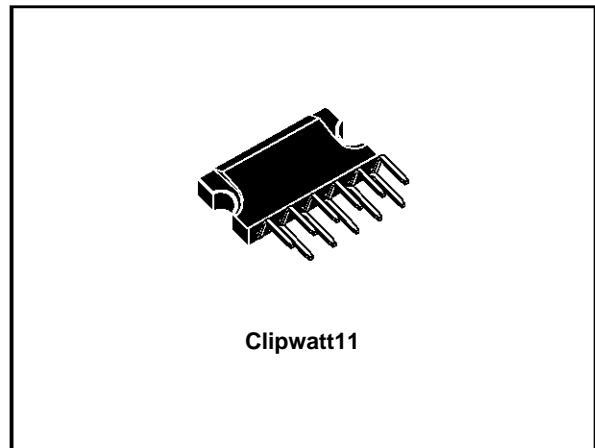


**8W AMPLIFIER WITH MUTING**

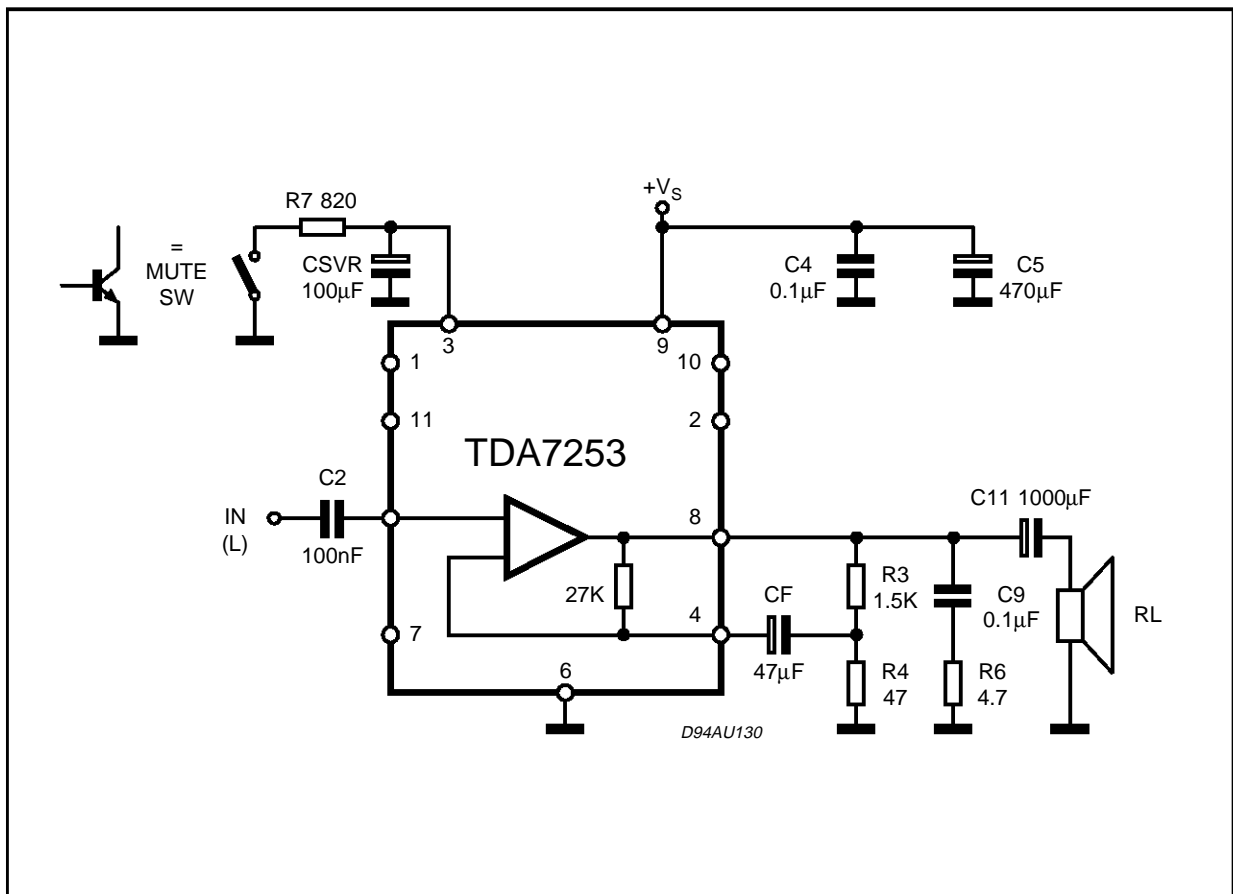
- WIDE SUPPLY VOLTAGE RANGE
- 8W @  $V_S=26V$ ,  $R_L = 8\Omega$ , THD=10%
- MUTE FACILITY (POP FREE) WITH LOW CONSUMPTION
- AC SHORT CIRCUIT PROTECTION
- THERMAL OVERLOAD PROTECTION (150°C)

**DESCRIPTION**

The TDA7253 is class AB audio power amplifier assembled in the new Clipwatt package.



**APPLICATION CIRCUIT**



# TDA7253

## ABSOLUTE MAXIMUM RATINGS

Symbol	Parameter	Value	Unit
$V_S$	Supply Voltage	35	V
$I_o$	Output Peak Current (repetitive $f > 20\text{Hz}$ )	2.5	A
$I_o$	Output Peak Current (non repetitive, $t = 100\mu\text{s}$ )	3.5	A
$P_{tot}$	Total Power Dissipation ( $T_{case} = 70^\circ\text{C}$ )	25	W
$T_{op}$	Operating Temperature Range	0 to 70	$^\circ\text{C}$
$T_{stg, T_j}$	Storage & Junction Temperature	-40 to 150	$^\circ\text{C}$

## PIN CONNECTION (Top view)

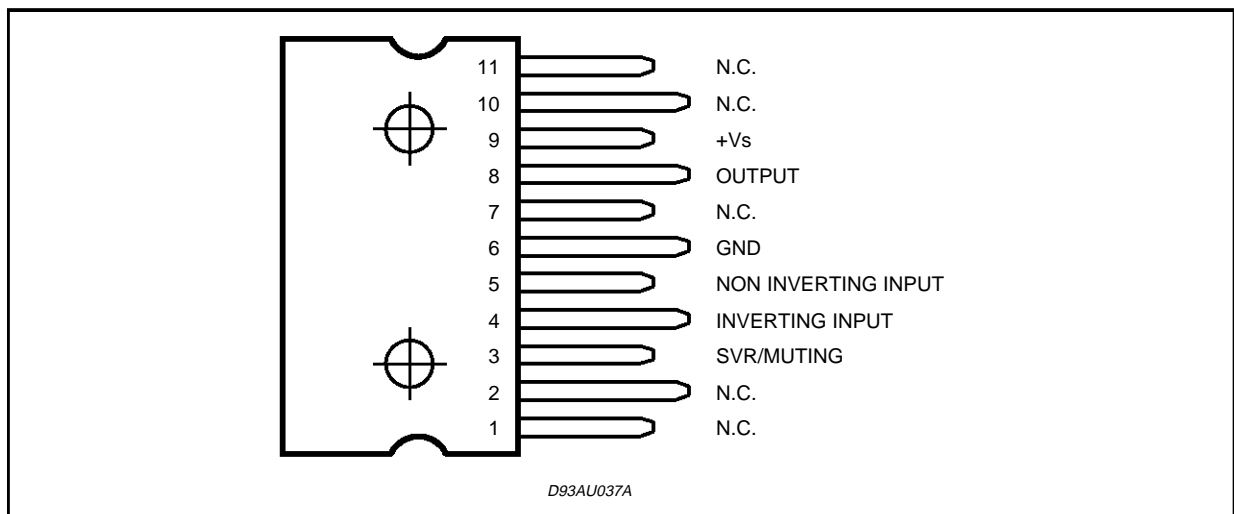
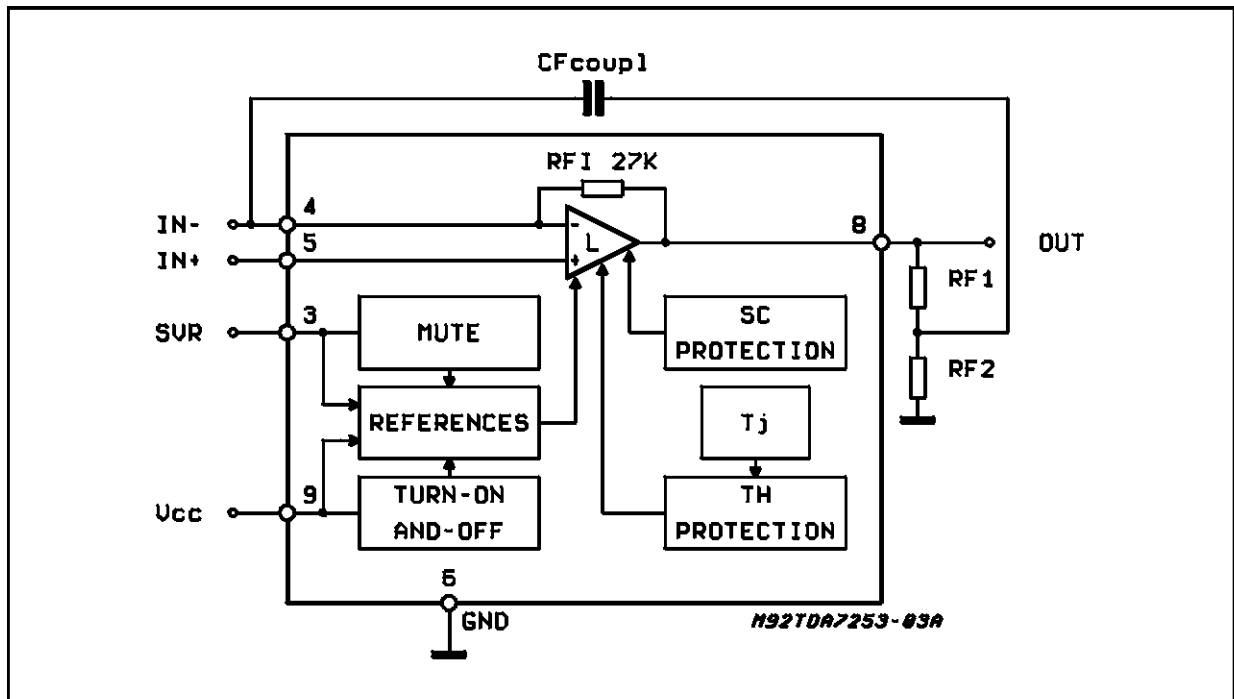


Figure 1: Application Circuit



**THERMAL DATA**

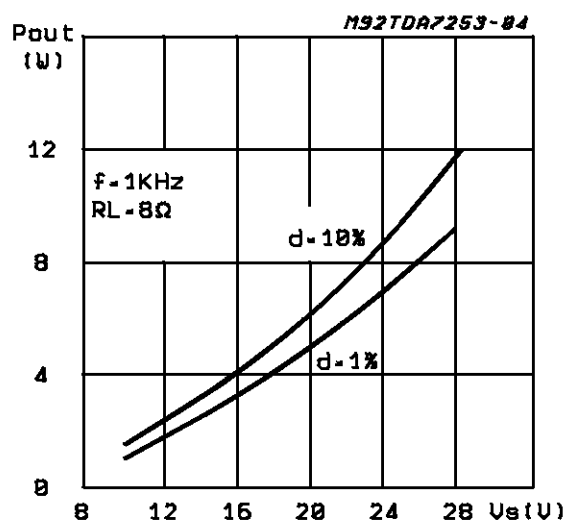
Symbol	Parameter	Value	Unit
R <sub>th j-case</sub>	Thermal resistance junction to case	Max 3	°C/W

**ELECTRICAL CHARACTERISTICS** (Refer to the test and application circuit, V<sub>S</sub> = 26V; R<sub>L</sub> = 8Ω; G<sub>v</sub> = 30dB; f = 1KHz; T<sub>amb</sub> = 25°C unless otherwise specified.)

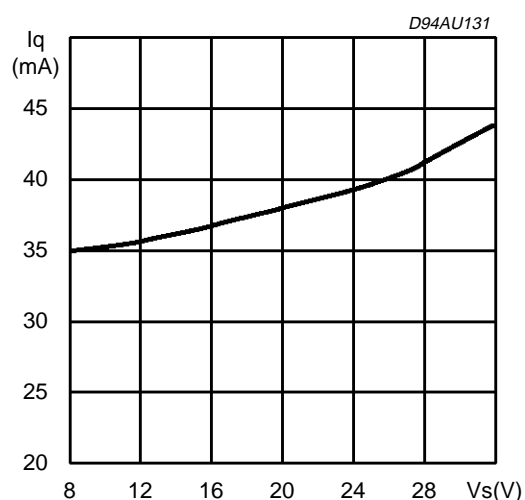
Symbol	Parameter	Test Condition	Min.	Typ.	Max.	Unit
V <sub>S</sub>	Supply Voltage		10		32	V
V <sub>O</sub>	Quiescent Output Voltage			12.5		V
I <sub>q</sub>	Total Quiescent Current			40		mA
P <sub>O</sub>	Output Power	d = 10% d = 1%	8	10 8		W W
d	Total Harmonic Distortion	P <sub>O</sub> = 1W		0.03		%
R <sub>I</sub>	Input Resistance		100	200		KΩ
f <sub>L</sub>	Low Frequency Roll-off (-3dB)			40		Hz
f <sub>H</sub>	High Frequency Roll-off (-3dB)			80		KHz
e <sub>N</sub>	Total Input Noise Voltage	A Curve; R <sub>S</sub> = 10KΩ f = 22Hz to 22KHz; R <sub>S</sub> = 10KΩ		2 2.5	10	mV μV
SVR	Supply Voltage Rejection	R <sub>S</sub> = 10KΩ; f = 100Hz; V <sub>r</sub> = 0.5V		60		dB
V <sub>T MUTE</sub>	Mute Threshold			0.8		V
V <sub>T PLAY</sub>	Play Threshold		5			V
A <sub>M</sub>	Mute Attenuation		80	100		dB
I <sub>q MUTE</sub>	Quiescent Current Mute			7	10	mA

Note: to avoid pop-on noise  $\frac{C_F}{C_{SVR}} \leq 1$

**Figure 1: Output Power vs. Supply Voltage**

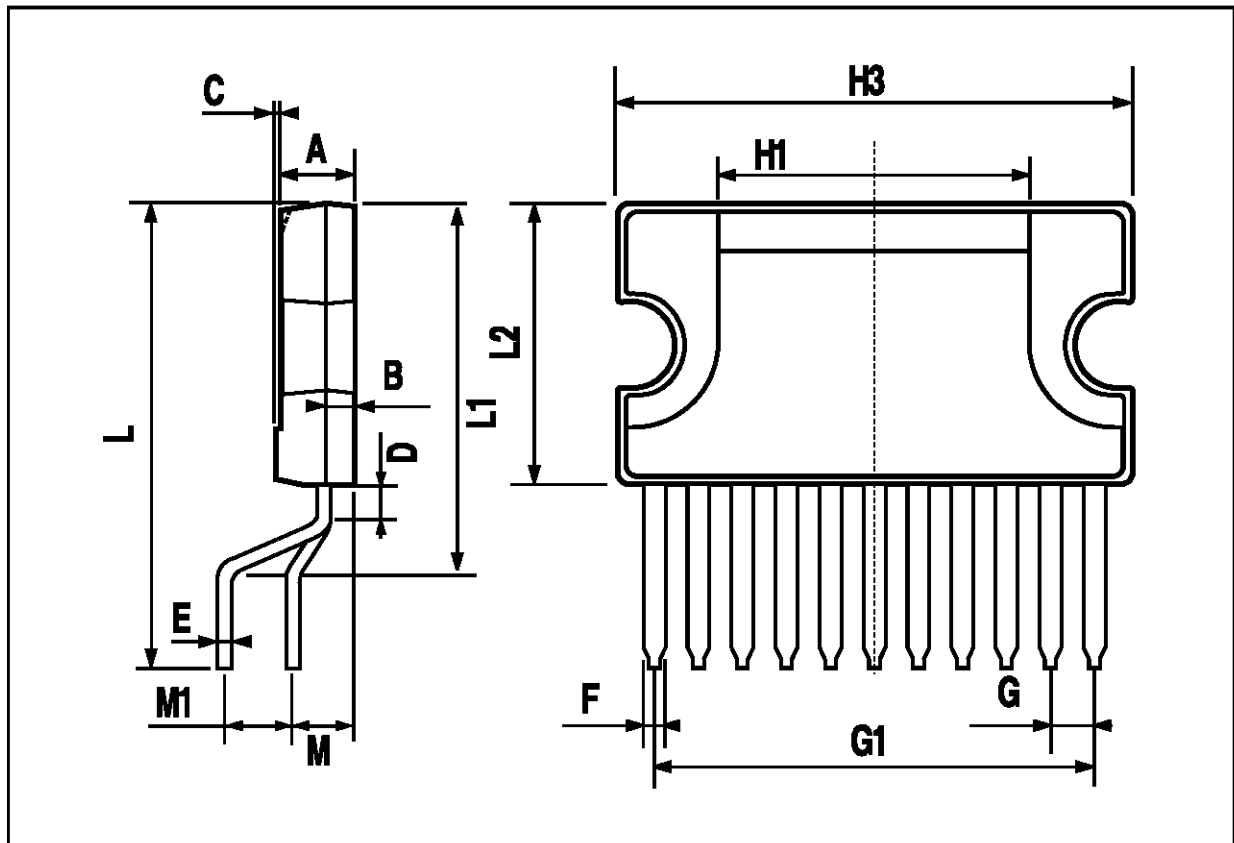


**Figure 2: Quiescent Current vs. Supply Voltage**



CLIPWATT11 PACKAGE MECHANICAL DATA

DIM.	mm			inch		
	MIN.	TYP.	MAX.	MIN.	TYP.	MAX.
A			3.10			0.122
B			1.10			0.04
C		0.15			0.006	
D		1.50			0.059	
E		0.52			0.02	
F		0.80			0.03	
G		1.70			0.066	
G1		17.00			0.66	
H1		12.00			0.48	
H3		20.00			0.79	
L		17.90			0.70	
L1		14.40			0.57	
L2		11.00			0.43	
M		2.54			0.1	
M1		2.54			0.1	



Information furnished is believed to be accurate and reliable. However, SGS-THOMSON Microelectronics assumes no responsibility for the consequences of use of such information nor for any infringement of patents or other rights of third parties which may result from its use. No license is granted by implication or otherwise under any patent or patent rights of SGS-THOMSON Microelectronics. Specification mentioned in this publication are subject to change without notice. This publication supersedes and replaces all information previously supplied. SGS-THOMSON Microelectronics products are not authorized for use as critical components in life support devices or systems without express written approval of SGS-THOMSON Microelectronics.

© 1997 SGS-THOMSON Microelectronics – Printed in Italy – All Rights Reserved

SGS-THOMSON Microelectronics GROUP OF COMPANIES

Australia - Brazil - Canada - China - France - Germany - Hong Kong - Italy - Japan - Korea - Malaysia - Malta - Morocco - The Netherlands - Singapore - Spain - Sweden - Switzerland - Taiwan - Thailand - United Kingdom - U.S.A.