

PWM-QR IC

TDA4605-3

Control IC for Switched-Mode
Power Supplies using
MOS-Transistors

Power Management & Supply



Never stop thinking.

Previous Version:

Page	Subjects (major changes since last revision)

For questions on technology, delivery and prices please contact the Infineon Technologies Offices in Germany or the Infineon Technologies Companies and Representatives worldwide: see our webpage at <http://www.infineon.com>

Edition 2002-07-01

**Published by Infineon Technologies AG,
St.-Martin-Strasse 53,
D-81541 München**

**© Infineon Technologies AG 1999.
All Rights Reserved.**

Attention please!

The information herein is given to describe certain components and shall not be considered as warranted characteristics.

Terms of delivery and rights to technical change reserved.

We hereby disclaim any and all warranties, including but not limited to warranties of non-infringement, regarding circuits, descriptions and charts stated herein.

Infineon Technologies is an approved CECC manufacturer.

Information

For further information on technology, delivery terms and conditions and prices please contact your nearest Infineon Technologies Office in Germany or our Infineon Technologies Representatives worldwide (see address list).

Warnings

Due to technical requirements components may contain dangerous substances. For information on the types in question please contact your nearest Infineon Technologies Office.

Infineon Technologies Components may only be used in life-support devices or systems with the express written approval of Infineon Technologies, if a failure of such components can reasonably be expected to cause the failure of that life-support device or system, or to affect the safety or effectiveness of that device or system. Life support devices or systems are intended to be implanted in the human body, or to support and/or maintain and sustain and/or protect human life. If they fail, it is reasonable to assume that the health of the user or other persons may be endangered.

Control IC for Switched-Mode Power Supplies using MOS-Transistor

TDA 4605-3

Bipolar IC

Features

- Fold-back characteristics provides overload protection for external components
- Burst operation under secondary short-circuit condition implemented
- Protection against open or a short of the control loop
- Switch-off if line voltage is too low (undervoltage switch-off)
- Line voltage depending compensation of fold-back point
- Soft-start for quiet start-up without noise generated by the transformer
- Chip-over temperature protection implemented (thermal shutdown)
- On-chip ringing suppression circuit against parasitic oscillations of the transformer
- AGC-voltage reduction at low load

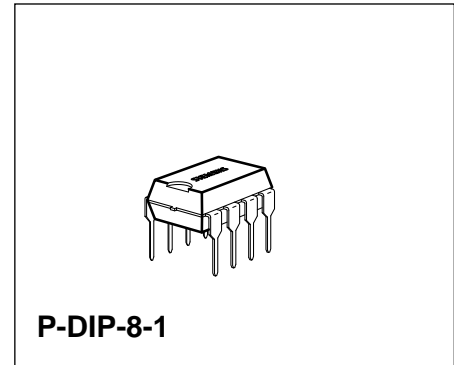

Type	Ordering Code	Package
TDA 4605-3	Q67000-A5066	P-DIP-8-1

The IC TDA 4605-3 controls the MOS-power transistor and performs all necessary control and protection functions in free running flyback converters. Because of the fact that a wide load range is achieved, this IC is applicable for consumer as well as industrial power supplies.

The serial circuit and primary winding of the flyback transformer are connected in series to the input voltage. During the switch-on period of the transistor, energy is stored in the transformer. During the switch-off period the energy is fed to the load via the secondary winding. By varying switch-on time of the power transistor, the IC controls each portion of energy transferred to the secondary side such that the output voltage remains nearly independent of load variations. The required control information is taken from the input voltage during the switch-on period and from a regulation winding during the switch-off period. A new cycle will start if the transformer has transferred the stored energy completely into the load.

In the different load ranges the switched-mode power supply (SMPS) behaves as follows:

No load operation

The power supply is operating in the burst mode at typical 20 to 40 kHz. The output voltage can be a little bit higher or lower than the nominal value depending of the design of the transformer and the resistors of the control voltage divider.

Nominal operation

The switching frequency is reduced with increasing load and decreasing AC-voltage. The output voltage is only dependent on the load.

Overload point

Maximal output power is available at this point of the output characteristic.

Overload

The energy transferred per operation cycle is limited at the top. Therefore the output voltages declines by secondary overloading.

Pin Definitions and Functions

Pin No.	Function
1	Information Input Concerning Secondary Voltage. By comparing the regulating voltage - obtained from the regulating winding of the transformer - with the internal reference voltage, the output impulse width on pin 5 is adjusted to the load of the secondary side (normal, overload, short-circuit, no load).
2	Information Input Regarding the Primary Current. The primary current rise in the primary winding is simulated at pin 2 as a voltage rise by means of external RC-element. When a voltage level is reached that's derived from the regulating voltage at pin 1, the output impulse at pin 5 is terminated. The RC-element serves to set the maximum power at the overload point set.
3	Input for Primary Voltage Monitoring: In the normal operation V_3 is moving between the thresholds V_{3H} and V_{3L} ($V_{3H} > V_3 > V_{3L}$). $V_3 < V_{3L}$: SMPS is switched OFF (line voltage too low). $V_3 > V_{3H}$: Compensation of the overload point regulation (controlled by pin 2) starts at V_{3H} : $V_{3L} = 1.7$.
4	Ground
5	Output: Push-pull output provides ± 1 A for rapid charge and discharge of the gate capacitance of the power MOS-transistor.
6	Supply Voltage Input: A stable internal reference voltage V_{REF} is derived from the supply voltage also the switching thresholds V_{6A} , V_{6E} , $V_{6\max}$ and $V_{6\min}$ for the supply voltage detector. If $V_6 > V_{6E}$ then V_{REF} is switched on and switched off when $V_6 < V_{6A}$. In addition the logic is only enable for $V_{6\min} < V_6 < V_{6\max}$.
7	Input for Soft-Start. Start-up will begin with short pulses by connecting a capacitor from pin 7 to ground.
8	Input for the Oscillation Feedback. After starting oscillation, every zero transition of the feedback voltage (falling edge) through zero (falling edge) triggers an output pulse at pin 5. The trigger threshold is at + 50 mV typical.

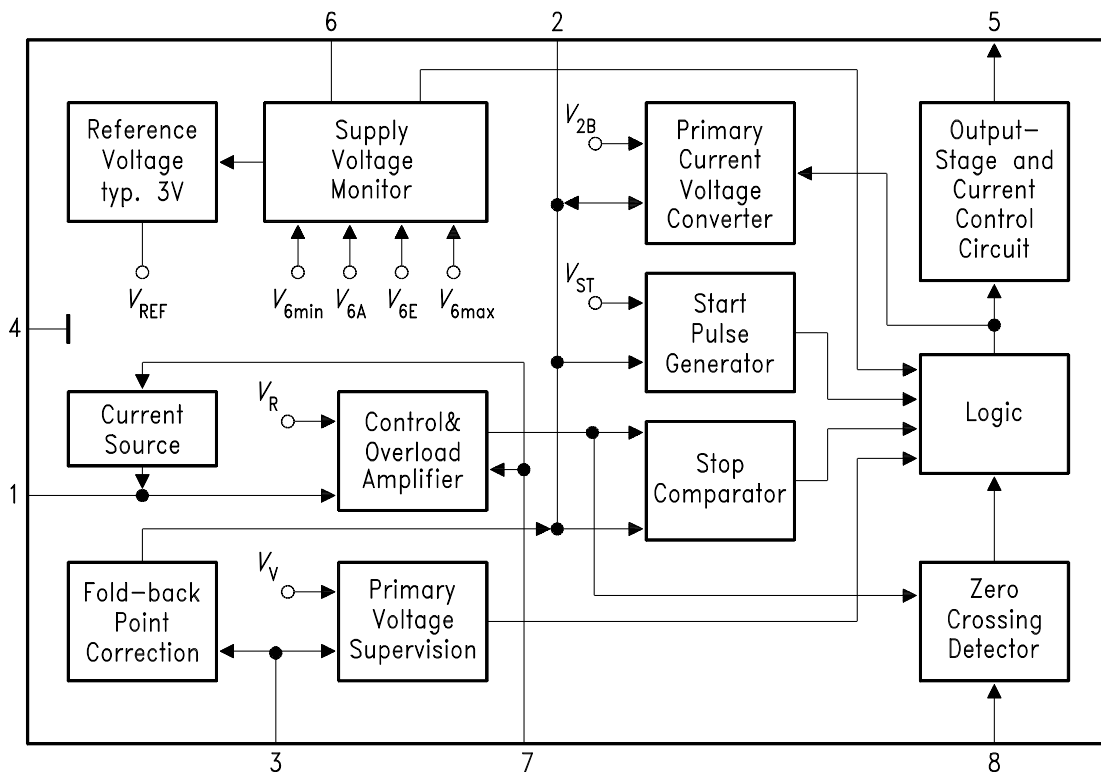

UEB03855

Block Diagram

Circuit Description

Application Circuit

The application circuit shows a flyback converter for video recorders with an output power rating of 70 W. The circuit is designed as a wide-range power supply for AC-line voltages of 180 to 264 V. The AC-input voltage is rectified by the bridge rectifier GR1 and smoothed by C_1 . The NTC limits the rush-in current.

In the period before the switch-on threshold is reached the IC is supplied via resistor R_1 ; during the start-up phase it uses the energy stored in C_2 , under steady state conditions the IC receives its supply voltage from transformer winding n_1 via diode D1. The switching transistor T1 is a BUZ 90. The parallel connected capacitor C_3 and the inductance of primary winding n_2 determine the system resonance frequency. The R_2 - C_4 -D2 circuitry limits overshoot peaks, and R_3 protects the gate of T1 against static charges.

During the conductive phase of the power transistor T1 the current rise in the primary winding depends on the winding inductance and the mains voltage. The network consisting of R_4 - C_5 is used to create a model of the sawtooth shaped rise of the collector current. The resulting control voltage is fed into pin 2 of the IC. The RC-time constant given by R_4 - C_5 must be designed that way that driving the transistor core into saturation is avoided.

The ratio of the voltage divider R_{10}/R_{11} is fixing a voltage level threshold. Below this threshold the switching power supply shall stop operation because of the low mains voltage. The control voltage present at pin 3 also determines the correction current for the fold-back point. This current added to the current flowing through R_4 and represents an additional charge to C_5 in order to reduce the turn-on phase of T1. This is done to stabilize the fold-back point even under higher mains voltages.

Regulation of the switched-mode power supplies via pin 1. The control voltage of winding n_1 during the off period of T1 is rectified by D3, smoothed by C_6 and stepped down at an adjustable ratio by R_5 , R_6 and R_7 . The R_8 - C_7 network suppresses parasitic overshoots (transformer oscillation). The peak voltage at pin 2, and thus the primary peak current, is adjusted by the IC so that the voltage applied across the control winding, and hence the output voltages, are at the desired level.

When the transformer has supplied its energy to the load, the control voltage passes through zero. The IC detects the zero crossing via series resistors R_9 connected to pin 8. But zero crossings are also produced by transformer oscillation after T1 has turned off if output is short-circuited. Therefore the IC ignores zero crossings occurring within a specified period of time after T1 turn-off.

The capacitor C_8 connected to pin 7 causes the power supply to be started with shorter pulses to keep the operating frequency outside the audible range during start-up.

On the secondary side, five output voltages are produced across winding n_3 to n_7 rectified by D4 to D8 and smoothed by C_9 to C_{13} . Resistors R_{12} , R_{14} and R_{19} to R_{21} are used as bleeder resistors. Fusible resistors R_{15} to R_{18} protect the rectifiers against short circuits in the output circuits, which are designed to supply only small loads.

Block Diagram

Pin 1

The regulating voltage forwarded to this pin is compared with a stable internal reference voltage V_R in the **regulating and overload amplifier**. The output of this stage is fed to the stop comparator. If the control voltage is rather small at pin 1 an additional current is added by means of current source which is controlled according the level at pin 7. This additional current is virtually reducing the control voltage present at pin 1.

Pin 2

A voltage proportional to the drain current of the switching transistor is generated there by the external RC-combination in conjunction with the **primary current transducer**. The output of this transducer is controlled by the logic and referenced to the internal stable voltage V_{2B} . If the voltage V_2 exceeds the output voltage of the regulations amplifier, the logic is reset by the stop comparator and consequently the output of pin 5 is switched to low potential. Further inputs for the logic stage are the output for the **start impulse generator** with the stable reference potential V_{ST} and the **supply voltage motor**.

Pin 3

The down divided primary voltage applied there stabilizes the overload point. In addition the logic is disabled in the event of low voltage by comparison with the internal stable voltage V_V in the **primary voltage monitor** block.

Pin 4

Ground

Pin 5

In the output stage the output signals produced by the logic are shifted to a level suitable for MOS-power transistors.

Pin 6

From the supply voltage V_6 are derived a stable internal references V_{REF} and the switching threshold V_{6A} , V_{6E} , $V_{6\max}$ and $V_{6\min}$ for the **supply voltage monitor**. All references values (V_R , V_{2B} , V_{ST}) are derived from V_{REF} . If $V_6 > V_{VE}$, the V_{REF} is switched on and switched off when $V_6 < V_{6A}$. In addition, the logic is released only for $V_{6\min} < V_6 < V_{6\max}$.

Pin 7

The output of the overload amplifier is connected to pin 7. A load on this output causes a reduction in maximal impulse duration. This function can be used to implement a soft start, when pin 7 is connected to ground by a capacitor.

Pin 8

The zero detector controlling the logic block recognizes the transformer being discharged by positive to negative zero crossing of pin 8 voltage and enables the logic for a new pulse. Parasitic oscillations occurring at the end of a pulse cannot lead to a new pulse (double pulsing), because an internal circuit inhibits the zero detector for a finite time t_{UL} after the end of each pulse.

Start-Up Behaviour

The start-up behaviour of the application circuit per sheet 88 is represented on sheet 90 for a line voltage barely above the lower acceptable limit time t_0 the following voltages built up:

- V_6 corresponding to the half-wave charge current over R_1
- V_2 to $V_{2\max}$ (typically 6.6 V)
- V_3 to the value determined by the divider R_{10}/R_{11} .

The current drawn by the IC in this case is less than 1.6 mA.

If V_6 reaches the threshold V_{6E} (time point t_1), the IC switches on the internal reference voltage. The current draw max. rises to 12 mA. The primary current-voltage reproducer regulates V_2 down to V_{2B} and the starting impulse generator generates the starting impulses from time point t_5 to t_6 . The feedback to pin 8 starts the next impulse and so on. All impulses including the starting impulse are controlled in width by regulating voltage of pin 1. When switching on this corresponds to a short-circuit event, i.e. $V_1 = 0$. Hence the IC starts up with "short-circuit impulses" to assume a width depending on the regulating voltage feedback (the IC operates in the overload range). The IC operates at the overload point. Thereafter the peak values of V_2 decrease rapidly, as the starting attempt is aborted (pin 5 is switched to low). As the IC remains switched on, V_6 further decreases to V_{6A} . The IC switches off; V_6 can rise again (time point t_4) and a new start-up attempt begins at time point t_1 . If the rectified alternating line voltage (primary voltage) collapses during load, V_3 can fall below V_{3A} , as is happening at time point t_3 (switch-on attempt when voltage is too low). The primary voltage monitor then clamps V_3 to V_{3S} until the IC switches off ($V_6 < V_{6A}$). Then a new start-up attempt begins at time point t_1 .

Regulation, Overload and No-Load Behaviour

When the IC has started up, it is operating in the regulation range. The potential at pin 1 typically is 400 mV. If the output is loaded, the regulation amplifier allows broader impulses ($V_5 = H$). The peak voltage value at pin 2 increases up to $V_{2S\ max}$. If the secondary load is further increased, the overload amplifier begins to regulate the pulse width downward. This point is referred to as the overload point of the power supply. As the IC-supply voltage V_6 is directly proportional to the secondary voltage, it goes down in accordance with the overload regulation behaviour. If V_6 falls below the value $V_{6\ min}$, the IC goes into burst operation. As the time constant of the half-wave charge-up is relatively large, the short-circuit power remains small. The overload amplifier cuts back to the pulse width t_{pk} . This pulse width must remain possible, in order to permit the IC to start-up without problems from the virtual short-circuit, which every switching on with $V_1 = 0$ represents. If the secondary side is unloaded, the loading impulses ($V_5 = H$) become shorter. The frequency increases up to the resonance frequency of the system. If the load is further reduced, the secondary voltages and V_6 increase. When $V_6 = V_{6\ max}$ the logic is blocked. The IC converts to burst operation. This renders the circuit absolutely safe under no-load conditions.

Behaviour when Temperature Exceeds Limit

An integrated temperature protection disables the logic when the chip temperature becomes too high. The IC automatically interrogates the temperature and starts as soon as the temperature decreases to permissible values.

Absolute Maximum Ratings
 $T_A = -20$ to $85\text{ }^\circ\text{C}$

Parameter		Symbol	Limit Values		Unit	Remarks
			min.	max.		
Voltages	pin 1	V_1	-0.3	3	V	Supply voltage
	pin 2	V_2	-0.3		V	
	pin 3	V_3	-0.3		V	
	pin 5	V_5	-0.3	V_6	V	
	pin 6	V_6	-0.3	20	V	
	pin 7	V_7	-0.3		V	
	Currents	pin 1	I_1		3	
pin 2		I_2		3	mA	
pin 3		I_3		3	mA	
pin 4		I_4	-1.5		A	
pin 5		I_5	-0.5	1.5	A	
pin 6		I_6		0.5	A	
pin 7		I_7		3	mA	
pin 8		I_8	-5	3	mA	
Junction temperature		T_j		125	$^\circ\text{C}$	
Storage temperature		T_{stg}	-40	125	$^\circ\text{C}$	

Operating Range

Supply voltage	V_6	7.5	15.5	V	IC "on"
Ambient temperature	T_A	-20	85	$^\circ\text{C}$	
Heat resistance					
Junction to environment	$R_{\text{th JE}}$		100	K/W	
Junction case	$R_{\text{th JC}}$		70	K/W	measured at pin 4

*) t_p = pulse width
v = duty circle

Characteristics
 $T_A = 25\text{ °C}; V_S = 10\text{ V}$

Parameter	Symbol	Limit Values			Unit	Test Condition	Test Circuit
		min.	typ.	max.			

Start-Up Hysteresis

Start-up current drain	I_{6E0}		0.6	0.8	mA	$V_6 = V_{6E}$	1
Switch-on voltage	V_{6E}	11	12	13	V		1
Switch-off voltage	V_{6A}	4.5	5	5.5	V		1
Switch-on current	I_{6E1}	7	11	14	mA	$V_6 = V_{6E}$	1
Switch-off current	I_{6A1}	5	10	13	mA	$V_6 = V_{6A}$	1

Voltage Clamp ($V_6 = 10\text{ V}$, IC switched off)

At pin 2 ($V_6 \leq V_{6E}$)	$V_{2\text{ max}}$	5.6	6.6	8	V	$I_2 = 1\text{ mA}$	1
At pin 3 ($V_6 \leq V_{6E}$)	$V_{3\text{ max}}$	5.6	7.7	8.3	V	$I_3 = 1\text{ mA}$	1

Control Range

Control input voltage	V_{1R}	390	400	410	mV		2
Voltage gain of the control circuit in the control range	$-V_R$	30	43	60	dB	$V_R = d$ $(V_{2S} - V_{2B}) / -dV_1$ $f = 1\text{ kHz}$	2

Primary Current Simulation Voltage

Basic value	V_{2B}	0.97	1.00	1.03	V		2
-------------	----------	------	------	------	---	--	---

Overload Range and Short-Circuit Operation

Peak value in the range of secondary overload	V_{2B}	2.9	3.0	3.1	V	$V_1 = V_{1R} - 10\text{ mV}$	2
Peak value in the range of secondary short-circuit operation	V_{2K}	2.2	2.4	2.6	V	$V_1 = 0\text{ V}$	2

Fold-Back Point Correction

Fold-back point correction current	$-I_2$	300	500	650	μA	$V_3 = 3.7\text{ V}$	1
------------------------------------	--------	-----	-----	-----	---------------	----------------------	---

Characteristics (cont'd)
 $T_A = 25\text{ °C}; V_S = 10\text{ V}$

Parameter	Symbol	Limit Values			Unit	Test Condition	Test Circuit
		min.	typ.	max.			

Generally Valid Data ($V_6 = 10\text{ V}$)
Voltage of the Zero Transition Detector

Positive clamping voltage	V_{8P}	0.7	0.75	0.82	V	$I_8 = 1\text{ mA}$	2
Negative clamping voltage	V_{8N}	-0.25	-0.2	-0.15	V	$I_8 = -1\text{ mA}$	2
Threshold value	V_{8S}	40	50	76	mV		2
Suppression of transformer ringing	t_{UL}	3.0	3.5	3.8	μs		2
Input current	$-I_8$	0		4	μA	$V_8 = 0$	2

Push-Pull Output Stage

Saturation voltages							
Pin 5 sourcing	V_{Sat0}		1.5	2.0	V	$I_5 = -0.1\text{ A}$	1
Pin 5 sinking	V_{SatV}		1.0	1.2	V	$I_5 = +0.1\text{ A}$	1
Pin 5 sinking	V_{SatV}		1.4	1.8	V	$I_5 = +0.5\text{ A}$	1

Output Slew Rate

Rising edge	$+dV_5/dt$		70		V/ μs		2
Falling edge	$+dV_5/dt$		100		V/ μs		2

Reduction of Control Voltage

Current to reduce the control voltage	$-I_1$		50	130	μA	$V_7 = 1.1\text{ V}, V_1 = 0.4\text{ V}$	
---------------------------------------	--------	--	----	-----	---------------	--	--

Characteristics (cont'd)
 $T_A = 25\text{ }^\circ\text{C}; V_S = 10\text{ V}$

Parameter	Symbol	Limit Values			Unit	Test Condition	Test Circuit
		min.	typ.	max.			

Protection Circuit

Undervoltage protection for V_6 : voltage at pin 5 = $V_{5\text{ min}}$ if $V_6 < V_{5\text{ min}}$	$V_{6\text{ min}}$	7.0	7.25	7.5	V		2
Undervoltage protection for V_6 : voltage at pin 5 = $V_{5\text{ min}}$ if $V_6 > V_{6\text{ max}}$	$V_{6\text{ max}}$	15.5	16	16.5	V		2
Undervoltage protection for V_{AC} : voltage at pin 4 = $V_{5\text{ min}}$ if $V_3 < V_{3A}$	V_{3A}	985	1000	1015	mV	$V_2 = 0\text{ V}$	1
Over temperature at the given chip temperature the IC will switch V_5 to $V_{5\text{ min}}$	T_j		150		$^\circ\text{C}$		2
Voltage at pin 3 if one of the protection function was triggered; (V_3 will be clamped until $V_6 < V_{6A}$)	$V_{3\text{Sat}}$		0.4	0.8	V	$I_3 = 750\text{ }\mu\text{A}$	1
Current drain during burst operation	I_6		8		mA	$V_3 = V_2 = 0\text{ V}$	1

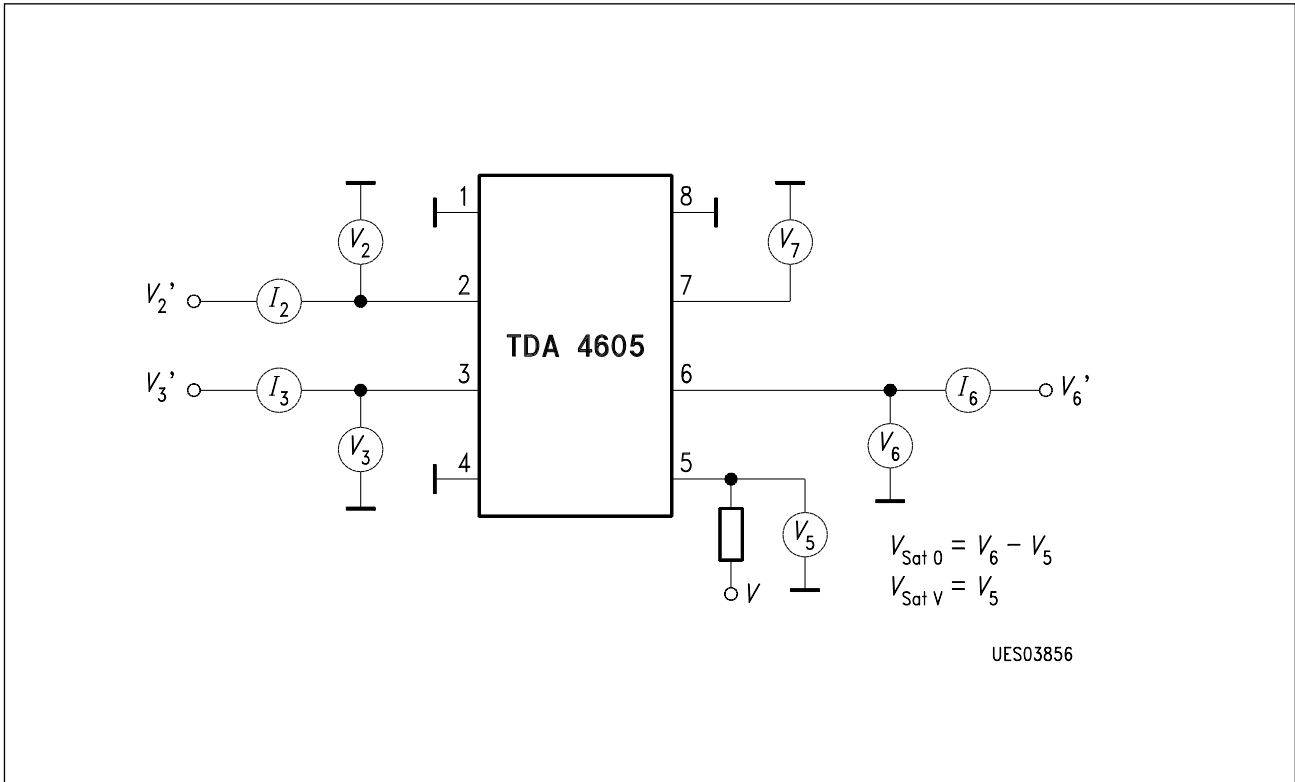

Test Circuit 1

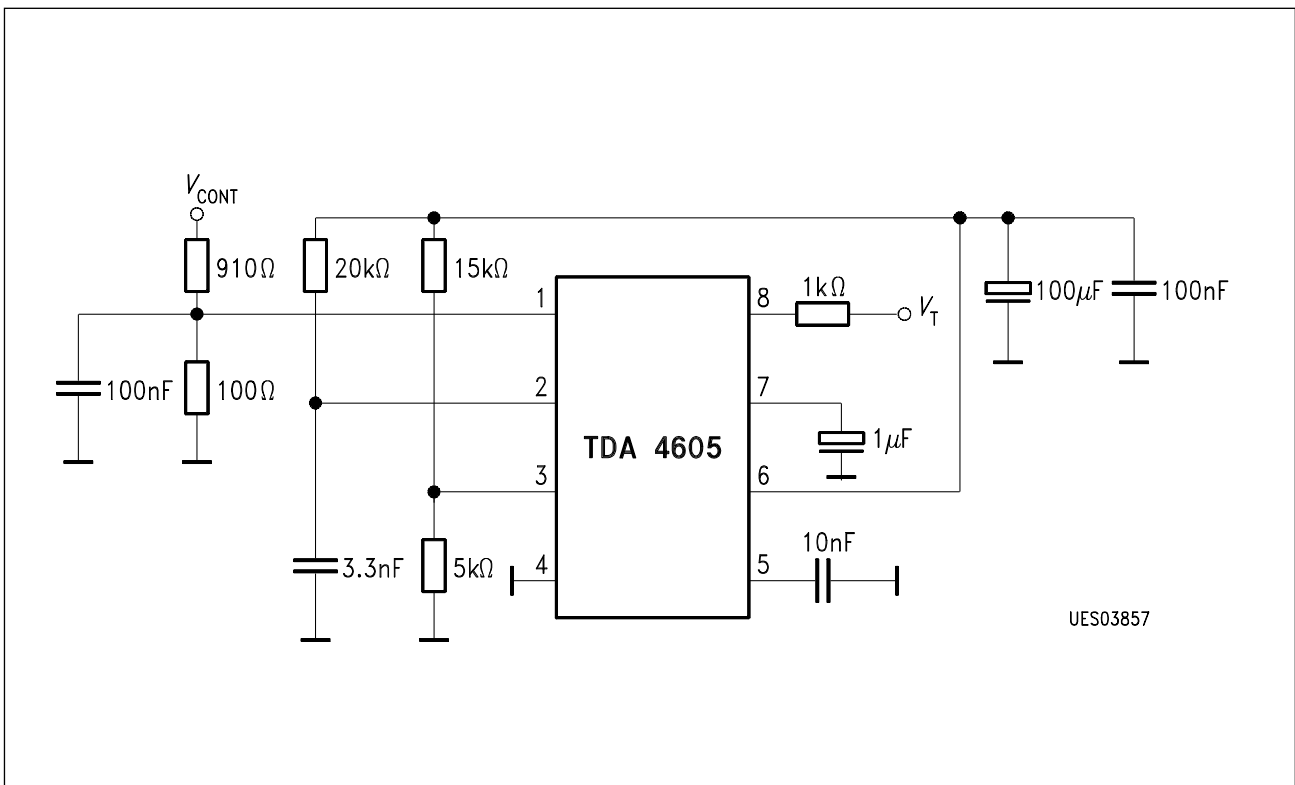

Test Circuit 2

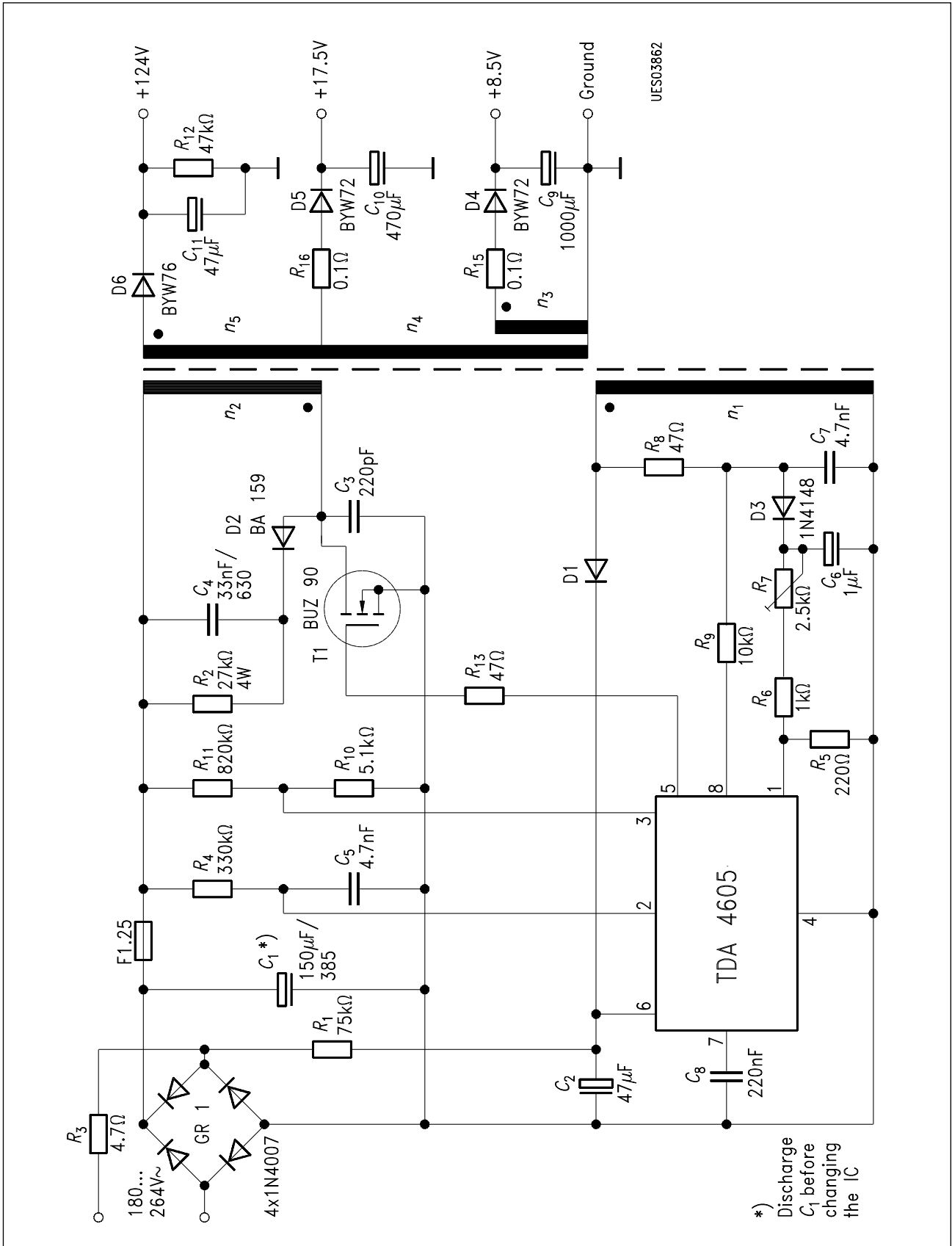

Application Circuit

Diagrams

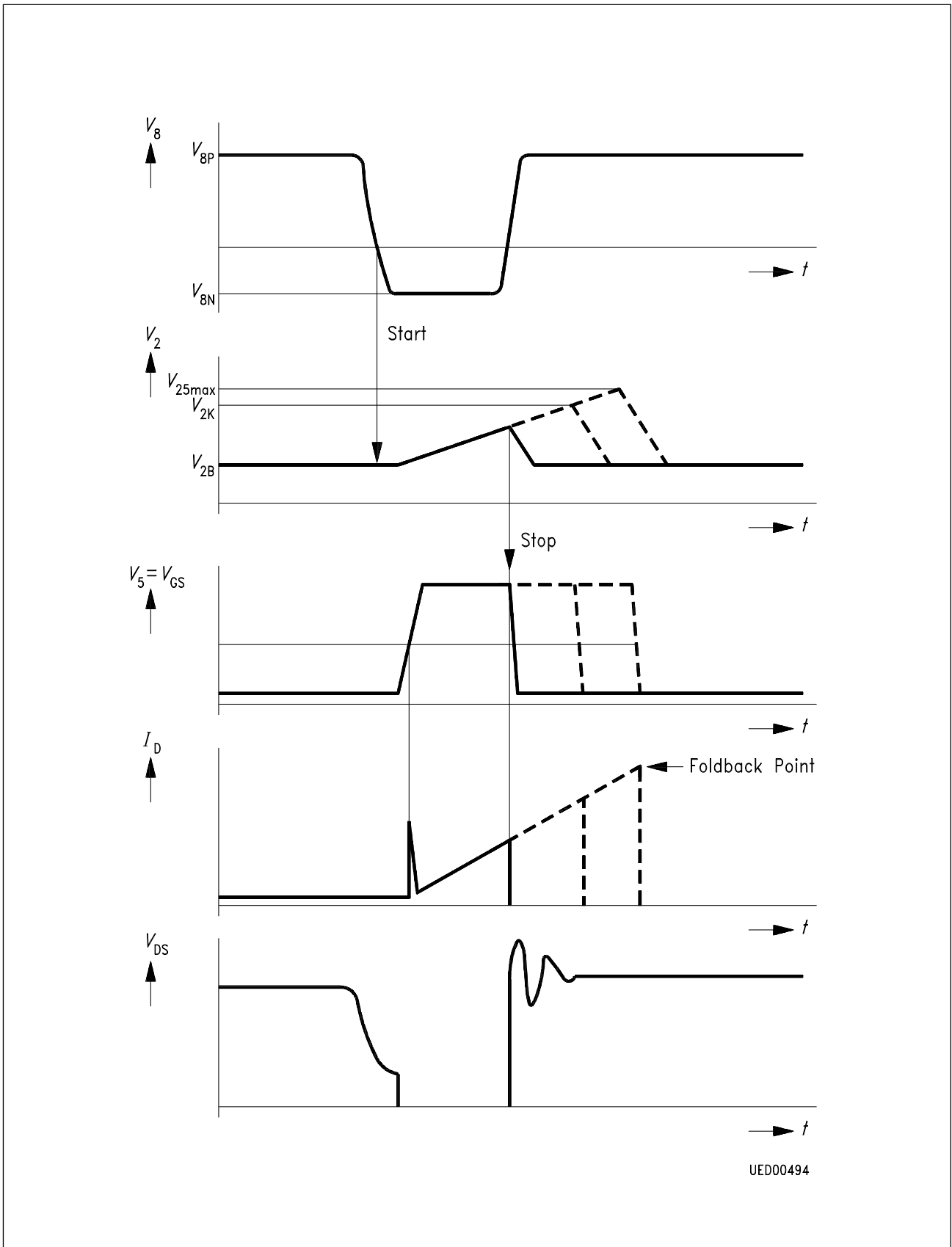

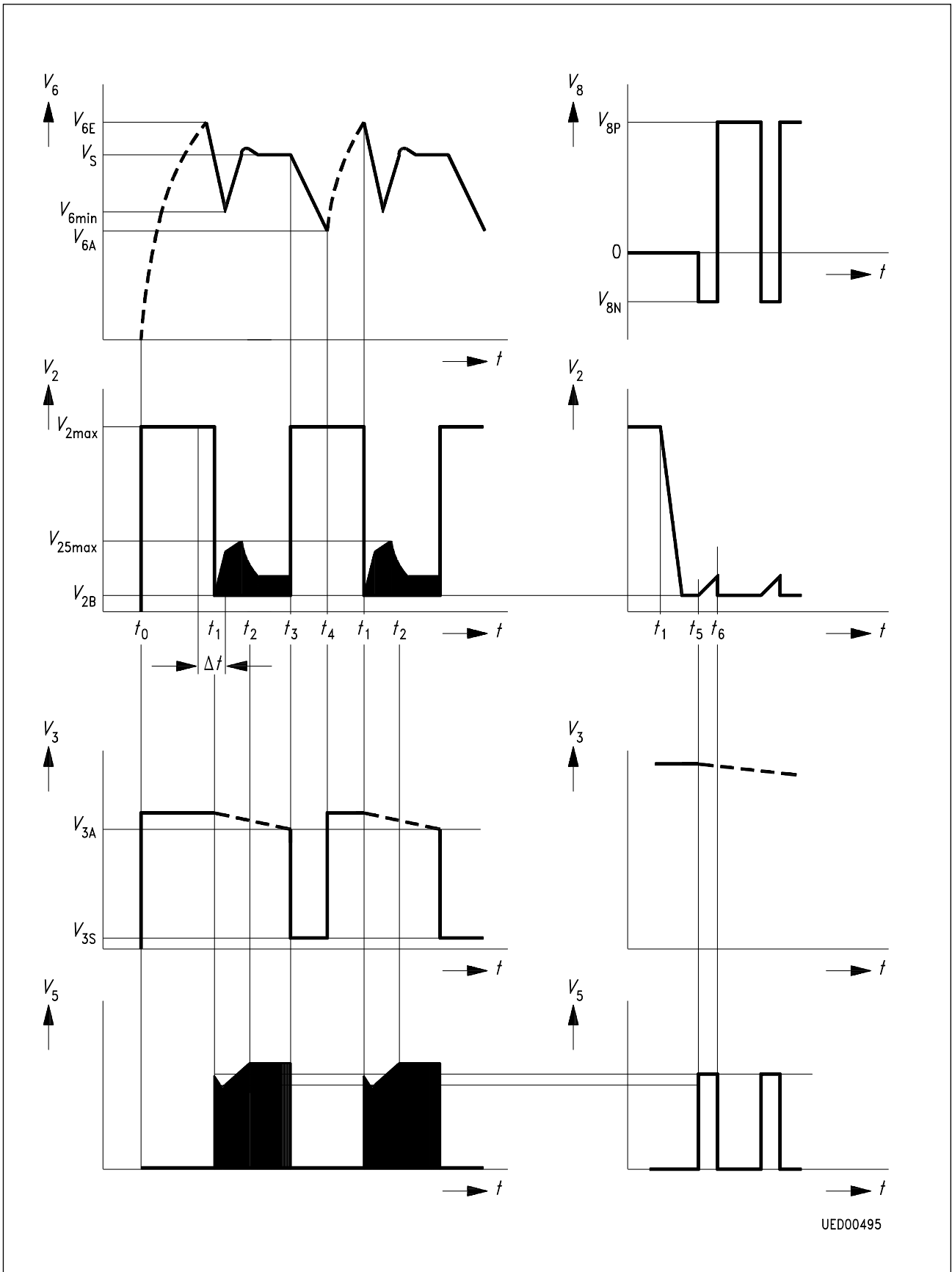

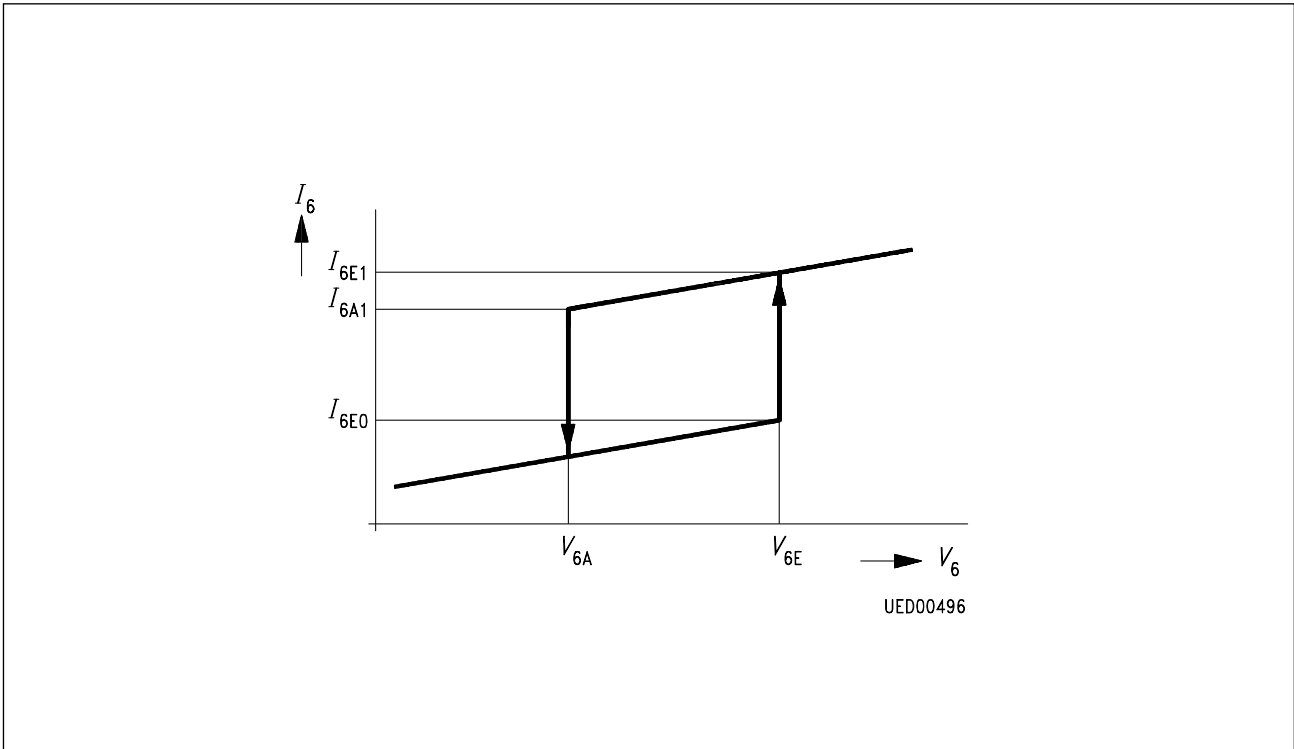

Start-Up Hysteresis

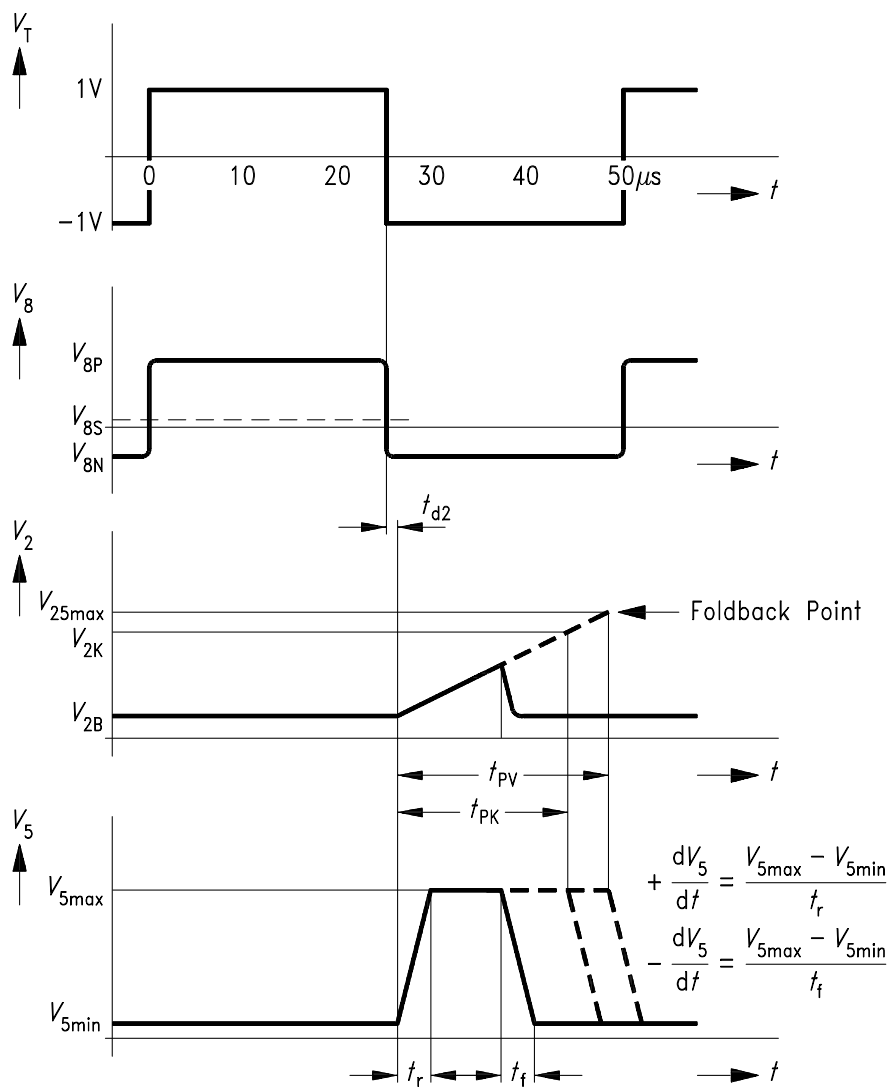

UED03859

Operation in Test Circuit 2

Start-Up Current as a Function of the Ambient Temperature

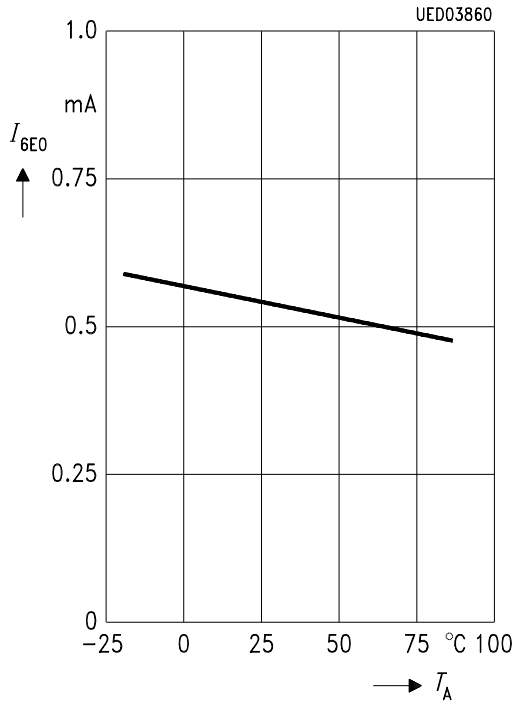

Overload Point Correction as a Function of the Voltage at Pin 3

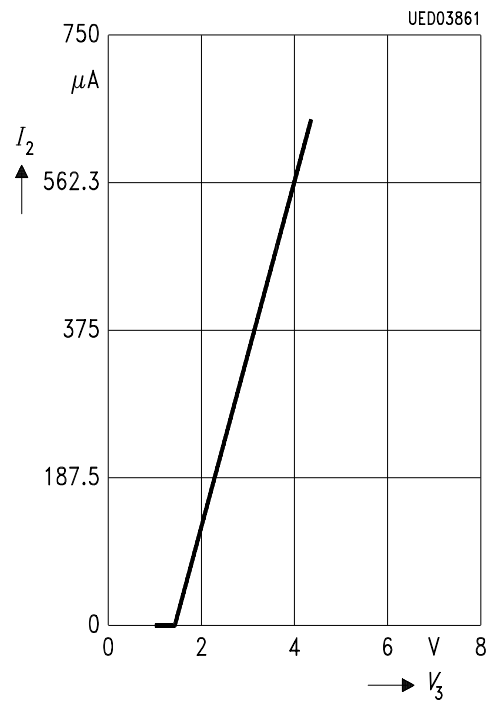

Recommended Heat Sink by 60 °C Ambient Temperature

Narrow Range 180 V ... 120 V ~

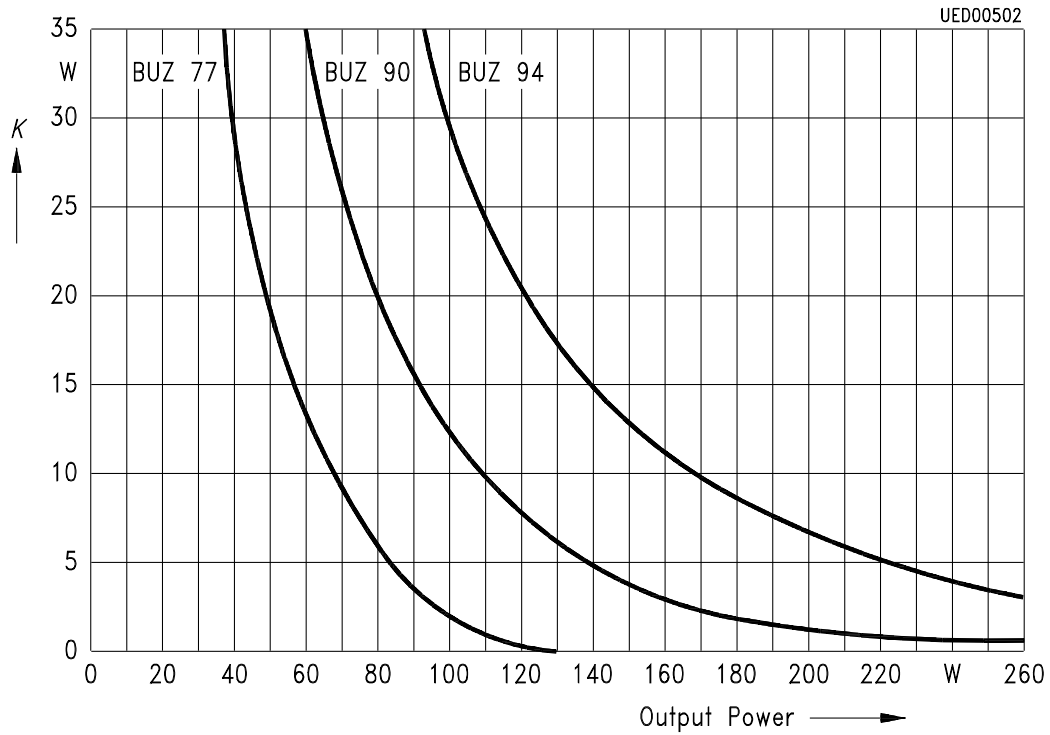

Narrow Range 90 V ... 270 V ~

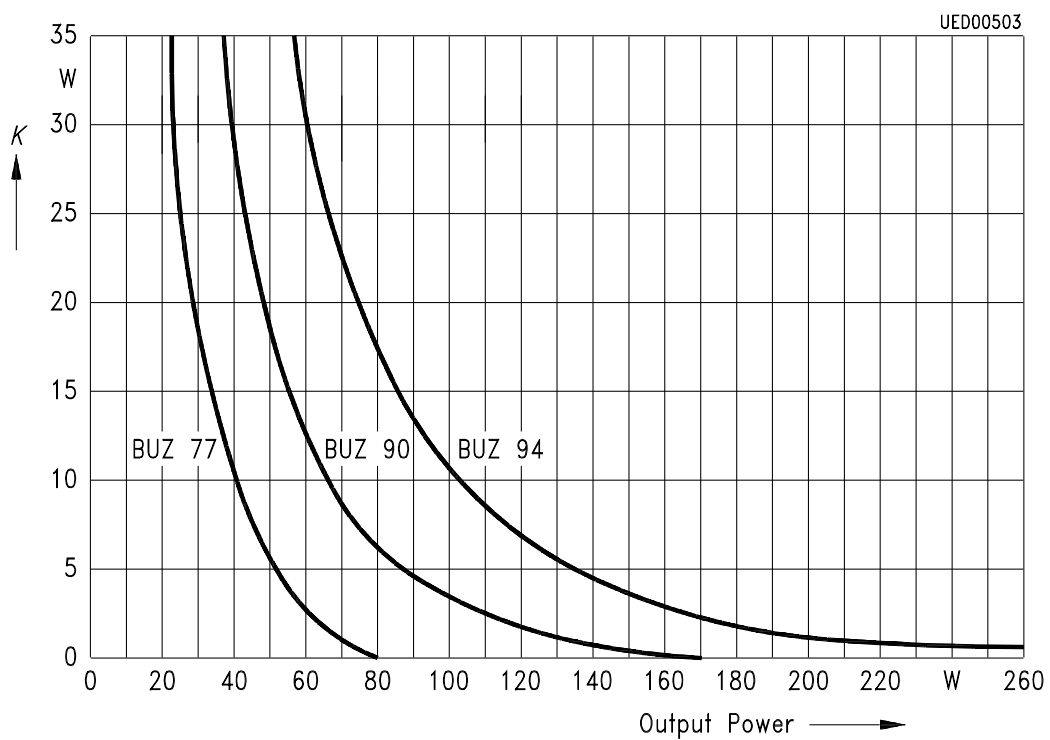

Total Quality Management

Qualität hat für uns eine umfassende Bedeutung. Wir wollen allen Ihren Ansprüchen in der bestmöglichen Weise gerecht werden. Es geht uns also nicht nur um die Produktqualität – unsere Anstrengungen gelten gleichermaßen der Lieferqualität und Logistik, dem Service und Support sowie allen sonstigen Beratungs- und Betreuungsleistungen.

Dazu gehört eine bestimmte Geisteshaltung unserer Mitarbeiter. Total Quality im Denken und Handeln gegenüber Kollegen, Lieferanten und Ihnen, unserem Kunden. Unsere Leitlinie ist jede Aufgabe mit „Null Fehlern“ zu lösen – in offener Sichtweise auch über den eigenen Arbeitsplatz hinaus – und uns ständig zu verbessern.

Unternehmensweit orientieren wir uns dabei auch an „top“ (Time Optimized Processes), um Ihnen durch größere Schnelligkeit den entscheidenden Wettbewerbsvorsprung zu verschaffen.

Geben Sie uns die Chance, hohe Leistung durch umfassende Qualität zu beweisen.

Wir werden Sie überzeugen.

Quality takes on an all-encompassing significance at Semiconductor Group. For us it means living up to each and every one of your demands in the best possible way. So we are not only concerned with product quality. We direct our efforts equally at quality of supply and logistics, service and support, as well as all the other ways in which we advise and attend to you.

Part of this is the very special attitude of our staff. Total Quality in thought and deed, towards co-workers, suppliers and you, our customer. Our guideline is “do everything with zero defects”, in an open manner that is demonstrated beyond your immediate workplace, and to constantly improve.

Throughout the corporation we also think in terms of Time Optimized Processes (top), greater speed on our part to give you that decisive competitive edge.

Give us the chance to prove the best of performance through the best of quality – you will be convinced.

<http://www.infineon.com>