

FM-IF HIGH QUALITY RADIO SYSTEM

- EXCEPTIONAL LIMITING SENSITIVITY
- VERY LOW DISTORTION (0.1% - DOUBLE TUNED DETECTOR COIL)
- IMPROVED S/N RATIO
- EXTERNALLY PROGRAMMABLE AUDIO LEVEL
- ON CHANNEL STEP FOR SEARCH CONTROL
- PROGRAMMABLE AGC VOLTAGE AND AFC FOR TUNER
- INTERCHANNEL MUTING (SQUELCH)
- DEVIATION MUTING
- DIRECT DRIVE OF TUNING METER

- DIRECT DRIVE OF FIELD STRENGTH METER

The TCA3189 is a monolithic integrated circuit in a 16-lead dual in-line plastic package, which provides a **complete subsystem** for amplification of 10.7MHz FM signal in Hi-Fi, car-radios and communications receivers.

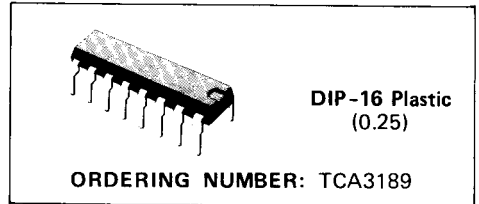

ABSOLUTE MAXIMUM RATINGS

V_s	Supply voltage	16	V
I_o	Output current (from pin 15)	2	mA
P_{tot}	Total power dissipation at $T_{amb} \leq 70^\circ\text{C}$	800	mW
T_{stg}	Storage temperature	-55 to 150	$^\circ\text{C}$
T_{op}	Operating temperature	-25 to 85	$^\circ\text{C}$

Double tuned detector coil

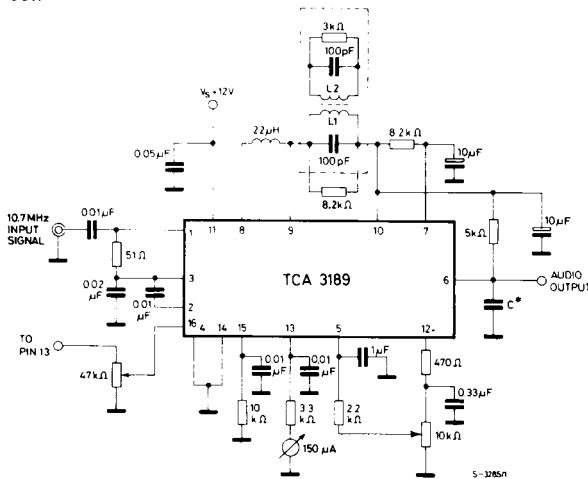

CONNECTION DIAGRAM

(top view)

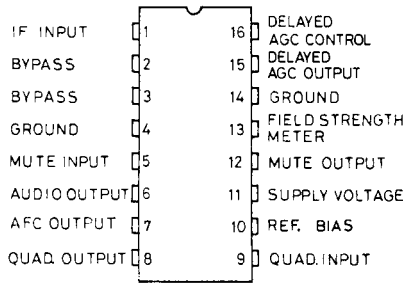

S-3286

BLOCK DIAGRAM

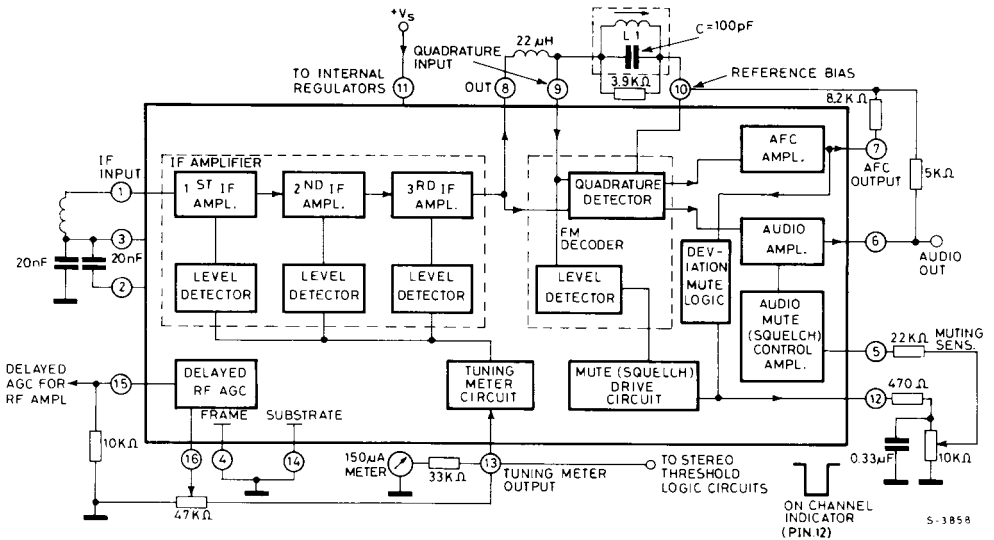

S-3858

THERMAL DATA

$R_{th\ j-amb}$	Thermal resistance junction-ambient	max.	100	°C/W
-----------------	-------------------------------------	------	-----	------

ELECTRICAL CHARACTERISTICS (Refer to the test circuit, $V_s = 12V$, $T_{amb} = 25^\circ C$)

Parameter		Test conditions	Min.	Typ.	Max.	Unit
V_s	Supply voltage range	No signal input, non muted	9		16	V
I_s	Supply current		20	31	44	mA
V_1	Voltage at the IF amplifier input		1.2	1.9	2.4	V
V_2, V_3	Voltage at the input bypass		1.2	1.9	2.4	V
V_{15}	Voltage at the pin 15 (RF AGC)		7.5	9.5	11	V
V_{10}	Reference bias voltage		5	5.6	6	V
V_i	Input limiting voltage (-3 dB) at pin 1	$f_o = 10.7\text{ MHz}$ $f_m = 1\text{ KHz}$ $\Delta f = \pm 75\text{ KHz}$		12	25	μV
V_o	Recovered audio voltage (pin 6)	$V_i \geq 50\ \mu V$ $f_o = 10.7\text{ MHz}$ $f_m = 1\text{ KHz}$ $\Delta f = \pm 75\text{ KHz}$	325	500	650	mV
d	Distortion (single tuned)	$V_i \geq 1\text{ mV}$ $f_o = 10.7\text{ MHz}$ $f_m = 1\text{ KHz}$ $\Delta f = \pm 75\text{ KHz}$		0.5	1	%
d	Distortion (double tuned)			0.1		%
$\frac{S+N}{N}$	Signal to noise ratio		65	72		dB
AMR	Amplitude modulation rejection	$V_i = 100\text{ mV}$ $f_o = 10.7\text{ MHz}$ $f_m = 1\text{ KHz}$ $\Delta f = \pm 75\text{ KHz}$ AM mod. 30%	45	55		dB
V_{16}	RF AGC threshold			1.25		V
$\frac{\Delta I_7}{\Delta f}$	AFC control slope			1.9		$\frac{\mu A}{KHz}$
V_{12}	On channel step (deviation mute)	$V_i = 100\text{ mV}$ $f_o = 10.7\text{ MHz}$	$f_{DEV.} < \pm 40\text{ KHz}$	0		V
			$f_{DEV.} > \pm 40\text{ KHz}$		5.6	

TEST CIRCUIT

Fig. 1 - Single tuned detector coil

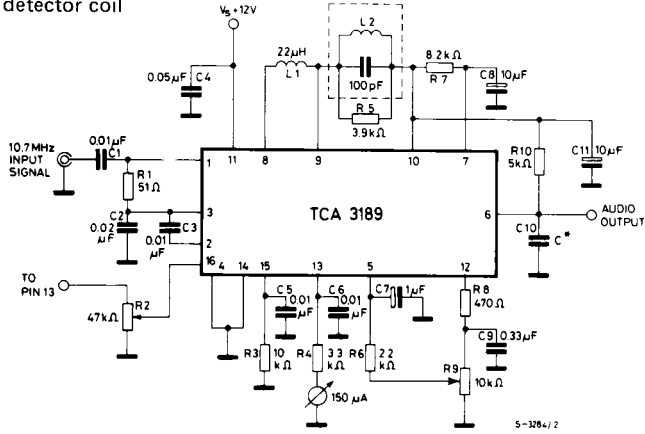

Fig. 2 - Limiting and noise characteristics

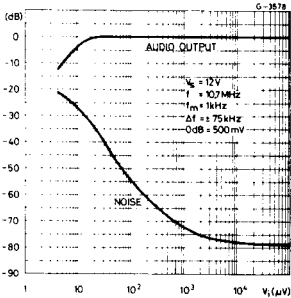

Fig. 5 - AFC characteristics

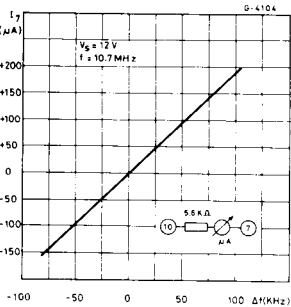

Fig. 3 - Deviation mute threshold vs. R7-10

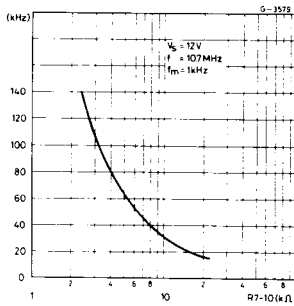

Fig. 6 - AGC voltage for FM tuner vs. input level

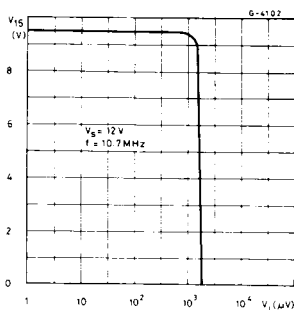

Fig. 4 - Recovered audio and muting action vs. input level

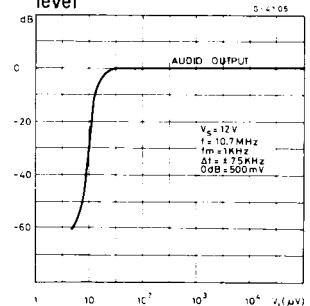

Fig. 7 - Field strength and tuning meter output vs. input level

