

# TC7SET125F, TC7SET125FU

## Bus Buffer

### Features

- High speed .....  $t_{pd} = 3.7 \text{ ns (typ.)}$   
at  $V_{CC} = 5 \text{ V}$
- Low power dissipation .....  $I_{CC} = 2 \mu\text{A (max)}$   
at  $T_a = 25^\circ\text{C}$
- Compatible with TTL outputs...  $V_{IL} = 0.8 \text{ V (max.)}$   
 $V_{IH} = 2.0 \text{ V (min.)}$
- 5.5V tolerant input.

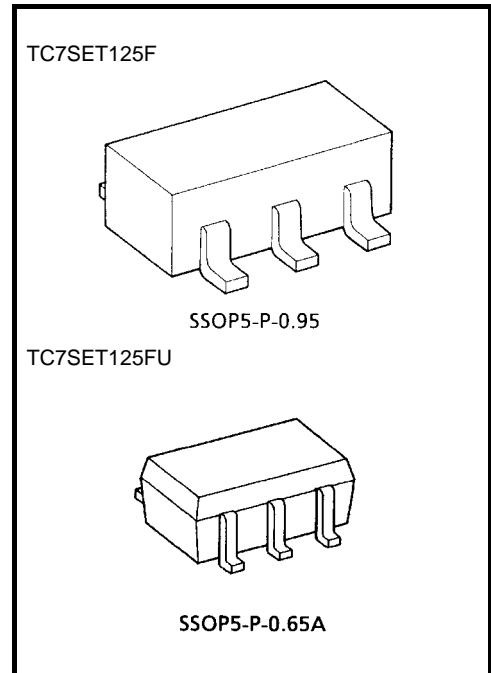

Weight  
 SSOP5-P-0.95 : 0.016 g (typ.)  
 SSOP5-P-0.65A : 0.006 g (typ.)

### Maximum Ratings ( $T_a = 25^\circ\text{C}$ )

Characteristics	Symbol	Rating	Unit
Supply voltage range	$V_{CC}$	-0.5~7.0	V
DC input voltage	$V_{IN}$	-0.5~7.0	V
DC output voltage	$V_{OUT}$	-0.5~ $V_{CC} + 0.5$	V
Input diode current	$I_{IK}$	-20	mA
Output diode current	$I_{OK}$	$\pm 20$	mA
DC output current	$I_{OUT}$	$\pm 25$	mA
DC $V_{CC}$ /ground current	$I_{CC}$	$\pm 50$	mA
Power dissipation	$P_D$	200	mW
Storage temperature	$T_{stg}$	-65~150	$^\circ\text{C}$
Lead temperature (10 s)	$T_L$	260	$^\circ\text{C}$

### Marking

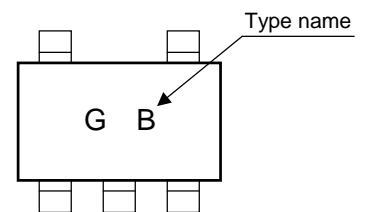

### Pin Assignment (top view)

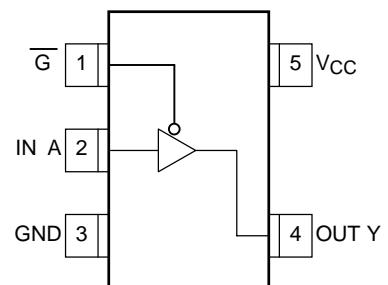

## Logic Diagram

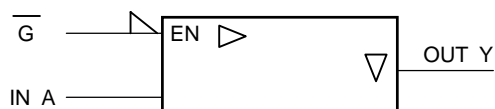

## Truth Table

$\overline{G}$	A	Y
H	X	Z
L	L	L
L	H	H

## Recommended Operating Conditions

Characteristics	Symbol	Rating	Unit
Supply voltage	$V_{CC}$	4.5~5.5	V
Input voltage	$V_{IN}$	0~5.5	V
Output voltage	$V_{OUT}$	0~ $V_{CC}$	V
Operating temperature	$T_{opr}$	-40~85	°C
Input rise and fall time	dt/dv	0~20	ns/V

## DC Electrical Characteristics

Characteristics	Symbol	Test Condition	$V_{CC}$ (V)	$T_a = 25^\circ\text{C}$			$T_a = -40\sim 85^\circ\text{C}$		Unit	
				Min	Typ.	Max	Min	Max		
High-level input voltage	$V_{IH}$	—	4.5~5.5	2.0	—	—	2.0	—	V	
Low-level input voltage	$V_{IL}$	—	4.5~5.5	—	—	0.8	—	0.8	V	
High-level output voltage	$V_{OH}$	$V_{IN} = V_{IH}$ or $V_{IL}$	$I_{OH} = -50 \mu\text{A}$	4.5	4.4	4.5	—	4.4	—	V
			$I_{OH} = -8 \text{ mA}$	4.5	3.94	—	—	3.80	—	
Low-level output voltage	$V_{OL}$	$V_{IN} = V_{IH}$ or $V_{IL}$	$I_{OL} = 50 \mu\text{A}$	4.5	—	0.0	0.10	—	0.10	V
			$I_{OL} = 8 \text{ mA}$	4.5	—	—	0.36	—	0.44	
3-state output off-state current	$I_{OZ}$	$V_{IN} = V_{IH}$ or $V_{IL}$ $V_{OUT} = V_{CC}$ or GND	5.5	—	—	$\pm 0.25$	—	$\pm 2.5$	$\mu\text{A}$	
Input leakage current	$I_{IN}$	$V_{IN} = 5.5 \text{ V}$ or GND	0~5.5	—	—	$\pm 0.1$	—	$\pm 1.0$	$\mu\text{A}$	
Quiescent supply current	$I_{CC}$	$V_{IN} = V_{CC}$ or GND	5.5	—	—	2.0	—	20.0	$\mu\text{A}$	
	$I_{CCT}$	Per Input : $V_{IN} = 3.4 \text{ V}$ Other Input : $V_{CC}$ or GND	5.5	—	—	1.35	—	1.50	mA	

## AC Characteristics (input: $t_r = t_f = 3 \text{ ns}$ )

Characteristics	Symbol	Test Condition		Ta = 25°C			Ta = -40~85°C		Unit
		V <sub>CC</sub> (V)	C <sub>L</sub> (pF)	Min	Typ.	Max	Min	Max	
Propagation delay time	t <sub>pLH</sub>	5.0 ± 0.5	15	—	3.7	6.0	1.0	6.9	ns
	t <sub>pHL</sub>		50	—	6.0	10.4	1.0	11.9	
3-state output enable time	t <sub>pZL</sub>	5.0 ± 0.5	15	—	3.6	5.6	1.0	6.5	ns
	t <sub>pZH</sub>		50	—	6.0	10.3	1.0	11.9	
3-state output disable time	t <sub>pLZ</sub> t <sub>pHZ</sub>	5.0 ± 0.5	50	—	7.3	10.0	1.0	11.5	ns
Input capacitance	C <sub>IN</sub>			—	4	10	—	—	pF
Output capacitance	C <sub>OUT</sub>			—	6	—	—	—	pF
Power dissipation capacitance	C <sub>PD</sub>	(Note)		—	15	—	—	—	pF

Note: C<sub>PD</sub> is defined as the value of the internal equivalent capacitance which is calculated from the operating current consumption without load.

Average operating current can be obtained by the equation:

$$I_{CC (opr)} = C_{PD} \cdot V_{CC} \cdot f_{IN} + I_{CC}$$

Package Dimensions

SSOP5-P-0.95

Unit : mm

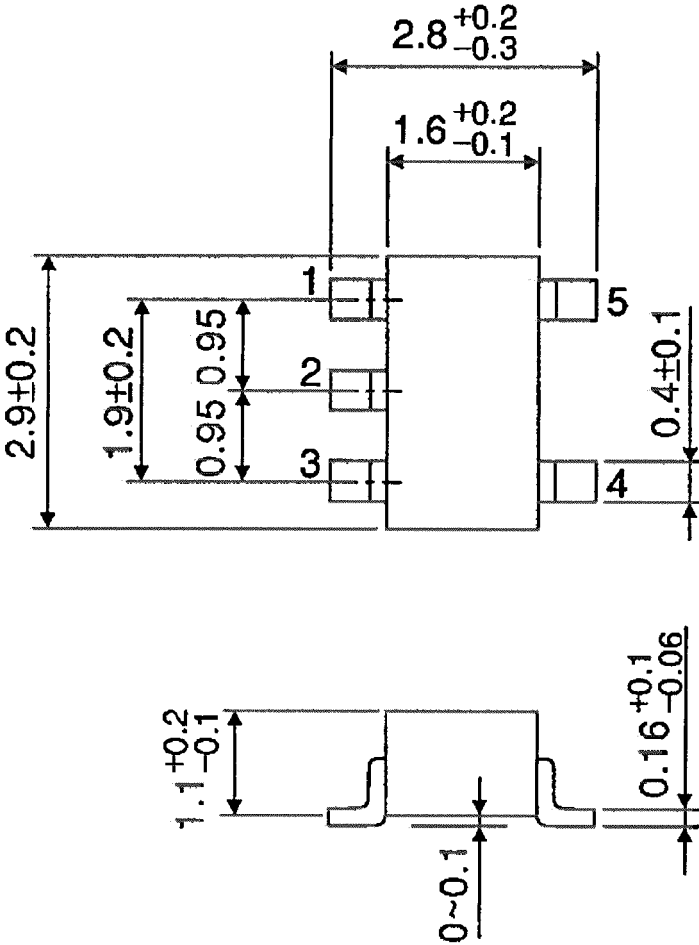

Weight: 0.016 g (typ.)

Package Dimensions

SSOP5-P-0.65A

Unit : mm

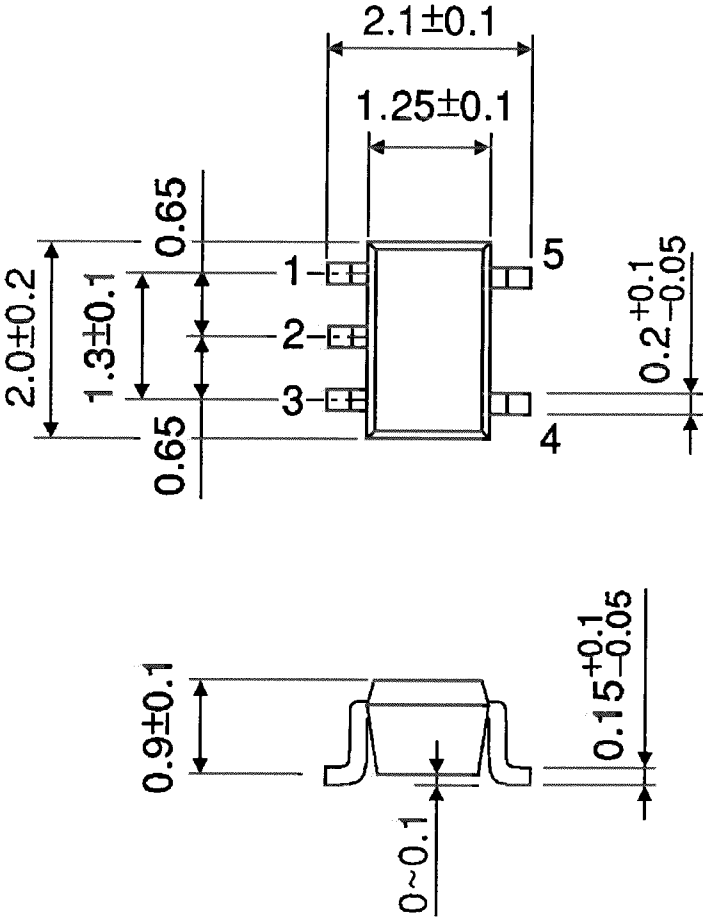

Weight: 0.006 g (typ.)

**RESTRICTIONS ON PRODUCT USE**

030619EBA

- The information contained herein is subject to change without notice.
- The information contained herein is presented only as a guide for the applications of our products. No responsibility is assumed by TOSHIBA for any infringements of patents or other rights of the third parties which may result from its use. No license is granted by implication or otherwise under any patent or patent rights of TOSHIBA or others.
- TOSHIBA is continually working to improve the quality and reliability of its products. Nevertheless, semiconductor devices in general can malfunction or fail due to their inherent electrical sensitivity and vulnerability to physical stress. It is the responsibility of the buyer, when utilizing TOSHIBA products, to comply with the standards of safety in making a safe design for the entire system, and to avoid situations in which a malfunction or failure of such TOSHIBA products could cause loss of human life, bodily injury or damage to property.  
In developing your designs, please ensure that TOSHIBA products are used within specified operating ranges as set forth in the most recent TOSHIBA products specifications. Also, please keep in mind the precautions and conditions set forth in the "Handling Guide for Semiconductor Devices," or "TOSHIBA Semiconductor Reliability Handbook" etc..
- The TOSHIBA products listed in this document are intended for usage in general electronics applications (computer, personal equipment, office equipment, measuring equipment, industrial robotics, domestic appliances, etc.). These TOSHIBA products are neither intended nor warranted for usage in equipment that requires extraordinarily high quality and/or reliability or a malfunction or failure of which may cause loss of human life or bodily injury ("Unintended Usage"). Unintended Usage include atomic energy control instruments, airplane or spaceship instruments, transportation instruments, traffic signal instruments, combustion control instruments, medical instruments, all types of safety devices, etc.. Unintended Usage of TOSHIBA products listed in this document shall be made at the customer's own risk.
- The products described in this document are subject to the foreign exchange and foreign trade laws.
- TOSHIBA products should not be embedded to the downstream products which are prohibited to be produced and sold, under any law and regulations.