

CD Integrated Circuit Silicon Monolithic

TC78S600FNG/FTG

Stepping Motor Driver IC

The TC78S600FNG/FTG is a PWM constant-current type stepping motor driver IC designed for sinusoidal-input micro-step control of stepping motors.

The TC78S600FNG/FTG can be used in applications that require 1-2-phase, W1-2-phase, 2W1-2 phase, and 4W1-2 phase excitation modes. The TC78S600FNG/FTG is capable of forward and reverse driving of a 2-phase bipolar stepping motor using only a clock signal.

Features

- Motor power supply voltage: $V_M = 15V$ (max)
 - Control power supply voltage: $V_{CC} = 2.7$ to $5.5V$ (operation range)
 - Output current: $I_{out} \leq 0.8A$ (max)
 - Output ON-resistance: $R_{on} = 1.2\Omega$ (upper and lower sum)
 - Decoder that enables micro step control with the clock signal
 - Selectable phase excitation modes (1-2, W1-2, 2W1-2, and 4W1-2)
 - Internal pull-down resistors on inputs: $200\text{ k}\Omega$ (typ.)
 - Output monitor pin (\overline{MO})
 - Over current protection (ISD), Thermal shutdown (TSD) circuit, and Undervoltage lockout (UVLO) circuit.
 - Package: SSOP20 and QFN24
 - Fast decay: always 12.5%
 - Built-in cross conduction protection circuit
-
- This product has a MOS structure and is sensitive to electrostatic discharge. When handling this product, ensure that the environment is protected against electrostatic discharge by using an earth strap, a conductive mat and an ionizer. Ensure also that the ambient temperature and relative humidity are maintained at reasonable levels.
 - Do not insert devices in the wrong orientation or incorrectly. Otherwise, it may cause the device breakdown, damage and/or deterioration.

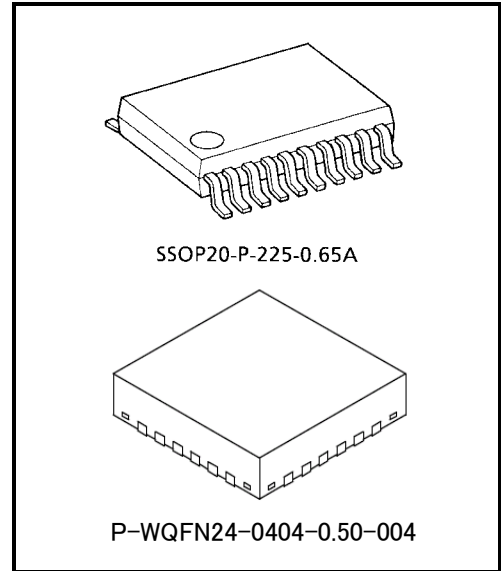

Weight: SSOP20-P-225-0.65A 0.09g(typ.)
 P-WQFN24-0404-0.50-004 0.03g(typ.)

Block Diagram

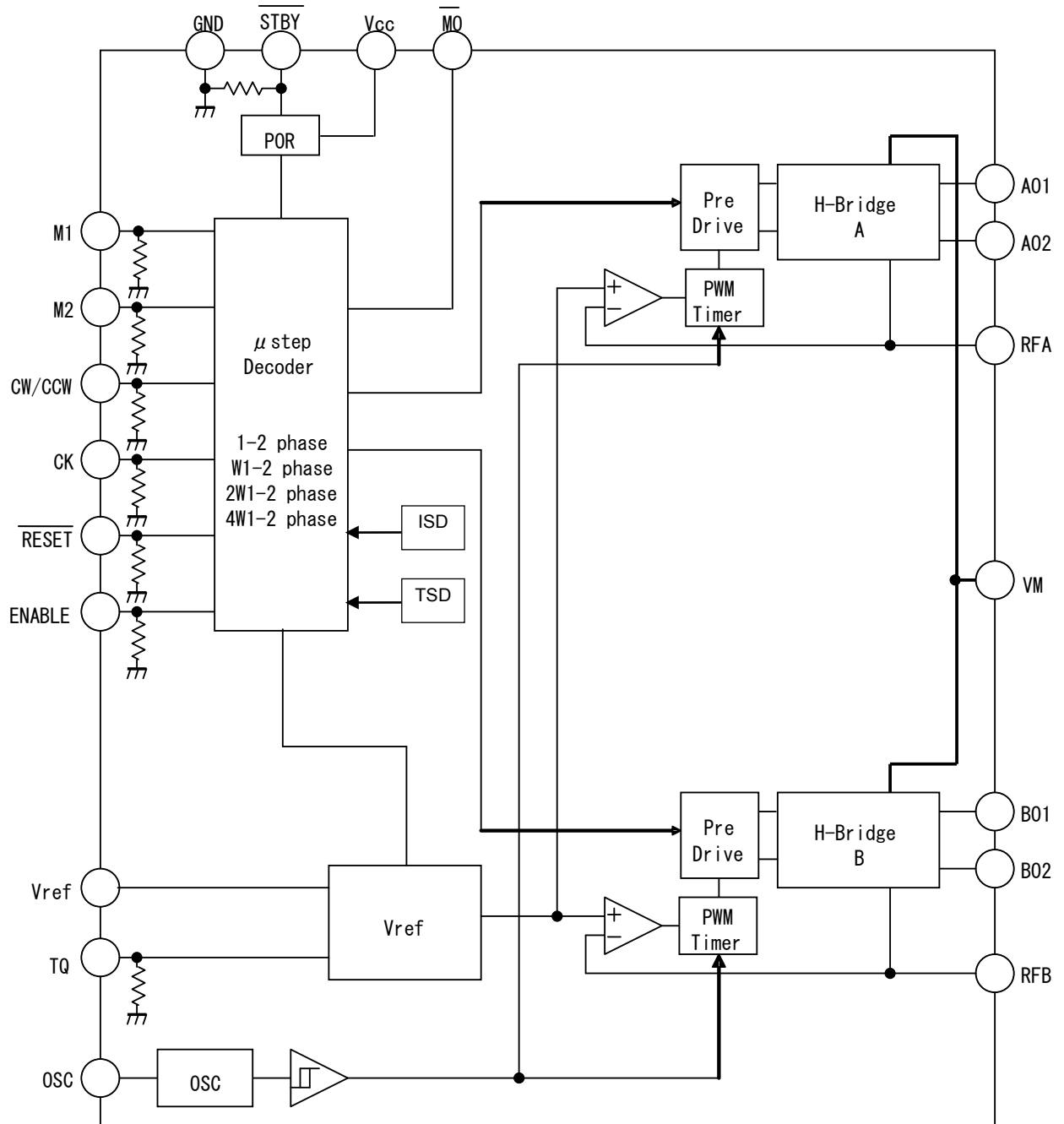

Pin Function

Pin No.		Symbol	Pin name	Remarks
FNG	FTG			
1	4, 5	Vcc	Power supply pin for logic block	$V_{CC(opr)} = 2.7$ to 5.5 V
2	6	\overline{STBY}	Standby input	See the Input Signals and Operating Modes
3	7	OSC	Connection pin for an external capacitor used for internal oscillation	
4	8	M1	Excitation mode setting input 1	See the Excitation Mode Settings
5	9	M2	Excitation mode setting input 2	See the Excitation Mode Settings
6	10, 11	VM	Power supply pin for output	$VM(opr) = 2.5$ to 15.0 V
7	12	CW/CCW	Rotation direction select input	See the Input Signals and Operating Modes
8	13	BO2	B-phase output 2	Connect BO2 to a motor coil pin.
9	14	RFB	Connection pin for a B-phase output current detection resistor	
10	15	BO1	B-phase output 1	Connect BO1 to a motor coil pin.
11	16	AO2	A-phase output 2	Connect AO2 to a motor coil pin.
12	17	RFA	Connection pin for an A-phase output current detection resistor	
13	18	AO1	A-phase output 1	Connect AO1 to a motor coil pin.
14	19	\overline{RESET}	Reset input	See the Input Signal and Operating Modes
15	20, 21	GND	Ground	
16	22	\overline{MO}	Monitor output	Initial state: $\overline{MO} = \text{Low}$ (open drain, pulled up by an external resistor)
17	23	TQ	Torque setting input	
18	1	Vref	V_{ref} setting input	See the Formula of Setting Current
19	2	ENABLE	Enable input	See the Input Signal and Operating Modes
20	3	CK	Clock input	

FTG: Pin No. 24 of QFN24: N.C.

<Pin circuit>

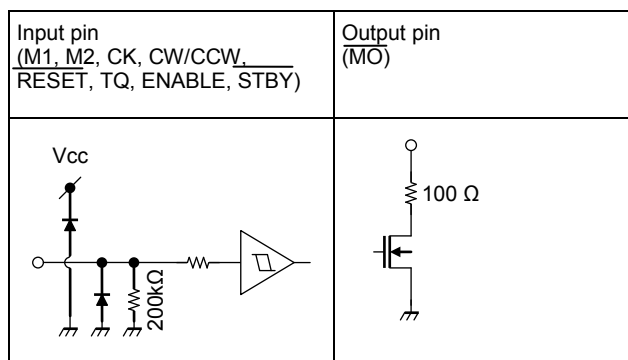

Pin Assignment (Top view)

FNG
SSOP20

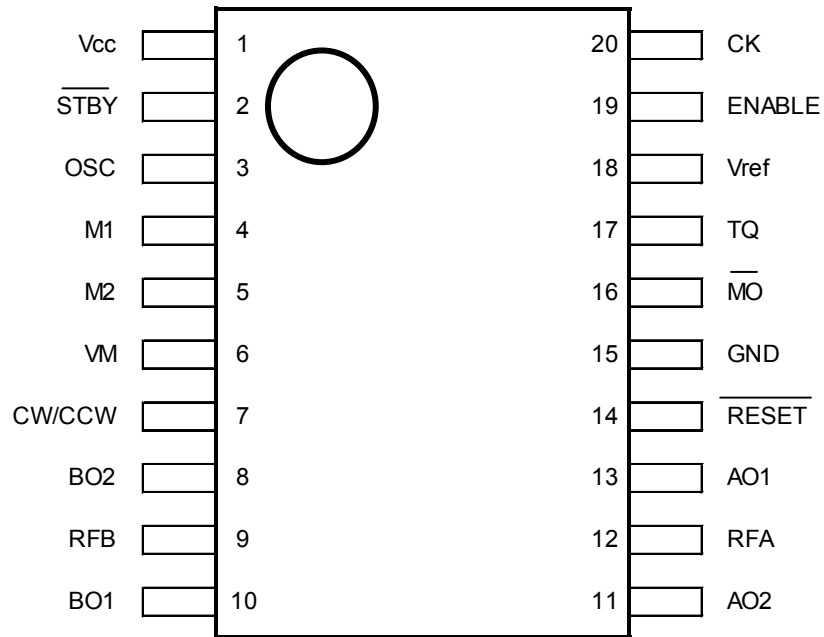

FTG
WQFN24

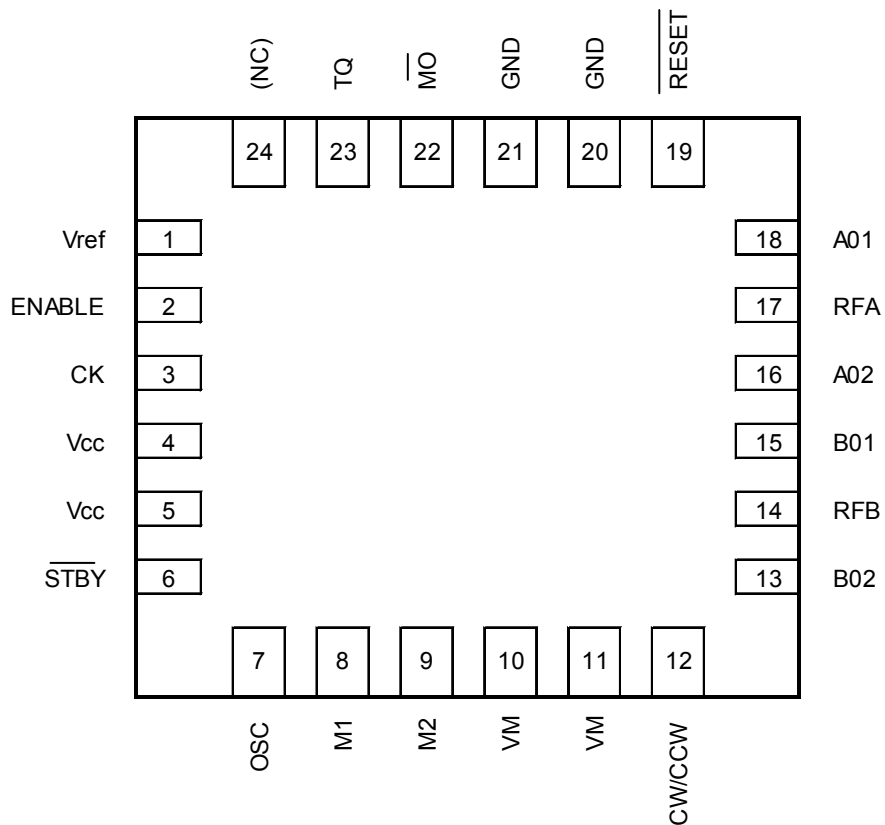

Absolute Maximum Ratings (Ta = 25°C)

Characteristics	Symbol	Rating	Unit	Remarks	
Power supply voltage	V _{CC}	6	V		
	V _M	18	V		
Output current	I _{out(AO)} and I _{out(BO)}	1.0	A	Peak, Per one phase, tw ≤ 10ms, duty ≤ 20%	
	I _{M\bar{O}}	4	mA		
Withstand voltage of $\bar{M}\bar{O}$	V _{M\bar{O}}	6	V		
Input voltage	V _{IN}	-0.2 to V _{CC} +0.2	V		
Power dissipation	P _D	FNG	0.71	W	IC only
			0.96		Mounted on a glass epoxy board (50 mm × 50 mm × 1.6 mm, Cu 40%)
		FTG	3.17		Mounted on a board of 76 mm × 114 mm × 1.6 mm, 4 layers (In accordance with JESDF-51).
Operating temperature	T _{opr}	-20 to 85	°C		
Storage temperature	T _{stg}	-55 to 150	°C		

The absolute maximum ratings of a semiconductor device are a set of ratings that must not be exceeded, even for a moment. Do not exceed any of these ratings.

Exceeding the rating (s) may cause the device breakdown, damage or deterioration, and may result injury by explosion or combustion.

Please use the IC within the specified operating ranges.

Operating Conditions (Ta = -20 to 85°C)

Characteristics	Symbol	Min	Typ.	Max	Unit
Control power supply voltage	V _{CC(opr)}	2.7	3.3	5.5	V
Motor power supply voltage	V _{M(opr)}	2.5	5	15	V
Output current	I _{OUT}	—	—	0.8	A
Input voltage	V _{IN}	—	—	5.5	V
Input voltage	V _{ref}	0.4	1.5	V _{CC} - 1.8 (Note 1)	V
Clock frequency	f _{ck}	—	1	60	kHz
OSC frequency	f _{osc}	160	320	480	kHz
Chopping frequency	f _{chop}	20	40	60	kHz

Note 1: Pay attention that V_{ref} should be 2.5V or less when T_Q is high.

Maximum current is limited by power dissipation and depends on the ambient temperature, excitation mode, and heat radiation of the board.

Electrical Characteristics

(Unless otherwise specified, Ta = 25°C, VCC = 3.3 V, VM = 5 V, RNF = 2 Ω, COSC = 220 pF.)

Characteristics	Symbol	Test Circuit	Test Condition	Min	Typ.	Max	Unit
Input voltage	V _{IN (H)} (1)	1	CW/CCW, <u>CK</u> , <u>RESET</u> , ENABLE, M1, M2, TQ, and STBY	2	—	5.5	V
	V _{IN (L)} (1)			-0.2	—	0.8	V
Input hysteresis voltage	V _H	—	CW/CCW, <u>CK</u> , <u>RESET</u> , ENABLE, M1, M2, TQ, and STBY	—	200	—	mV
Input current	I _{INH}	1	V _{IN} = 3.3V	11	16.5	22	μA
	I _{INL}		V _{IN} = GND	2	4	8	μA
Dynamic supply current	I _{CC1}	2	Output open, ENABLE:H, <u>RESET</u> :H	—	4	6	mA
	I _{CC2}		ENABLE:L	—	4	6	mA
	I _{CC3}		Standby mode	—	5	10	μA
	I _{M1}		Output open, ENABLE:H, <u>RESET</u> :H	—	1	2	mA
	I _{M2}		ENABLE:L	—	0.5	1	mA
	I _{M3}		Standby mode	—	—	1	μA
Comparator reference voltage	V _{RFA(1)} , V _{RFB(1)}	3	R _{NF} = 1Ω, V _{ref} = 1.0 V, TQ = L	0.040	0.050	0.060	V
	V _{RFA(2)} , V _{RFB(2)}		R _{NF} = 1Ω, V _{ref} = 1.0 V, TQ = H	—	0.200	—	
Channel-to-channel voltage differential	ΔV _O	—	B/A, TQ:H	-8	—	8	%
Undervoltage lockout threshold at V _{CC}	Lower threshold UVLD	—	Design target value (Note 1)	—	2.2	—	V
	Upper threshold UVLC	—	Design target value (Note 1)	—	2.3	—	V
Undervoltage lockout threshold at VM	Lower threshold UVLD	—	Design target value (Note 1)	—	2.0	—	V
	Upper threshold UVLC	—	Design target value (Note 1)	—	2.1	—	V
MO output voltage	V _{MO}	—	I _{MO} = 1mA	—	—	0.5	V
TSD operating temperature	TSD	—	Design target value (Note 1)	—	170	—	°C
TSD recovery temperature	TSDhys	—	Design target value (Note 1)	—	40	—	°C
OSC frequency	f _{osc}	—	C _{OSC} = 220 pF	210	320	430	kHz

(Note 1) Toshiba does not implement testing before shipping.

Output Block

Characteristics					Symbol	Test circuit	Test Condition		Min	Typ.	Max	Unit
Output saturation voltage					V_{SAT} (U+L)	4	$I_{OUT} = 0.2\text{ A}$		—	0.24	0.32	V
							$I_{OUT} = 0.6\text{ A}$		—	0.72	0.96	
Diode forward voltage					V_{FU}	5	$I_{OUT} = 0.6\text{ A}$		—	1	1.2	V
					V_{FL}				—	1	1.2	
A-/B-phase chopping current (Note)	4W1-2 phase excitation	2W1-2 phase excitation	W1-2 phase excitation	1-2 phase excitation	Vector	3	$\theta = 0$	TQ: H $R_{NF} = 1\Omega$ $V_{ref} = 1.0\text{ V}$ $C_{OSC} = 220\text{ pF}$	—	0.200	—	V
	4W1-2 phase excitation						$\theta = 1/16$		0.190	0.200	0.210	
	4W1-2 phase excitation	2W1-2 phase excitation					$\theta = 2/16$		0.186	0.196	0.206	
	4W1-2 phase excitation						$\theta = 3/16$		0.182	0.192	0.202	
	4W1-2 phase excitation	2W1-2 phase excitation	W1-2 phase excitation				$\theta = 4/16$		0.174	0.184	0.194	
	4W1-2 phase excitation						$\theta = 5/16$		0.166	0.176	0.186	
	4W1-2 phase excitation	2W1-2 phase excitation					$\theta = 6/16$		0.156	0.166	0.176	
	4W1-2 phase excitation						$\theta = 7/16$		0.144	0.154	0.164	
	4W1-2 phase excitation	2W1-2 phase excitation	W1-2 phase excitation	1-2 phase excitation			$\theta = 8/16$		0.132	0.142	0.152	
	4W1-2 phase excitation						$\theta = 9/16$		0.116	0.126	0.136	
	4W1-2 phase excitation	2W1-2 phase excitation					$\theta = 10/16$		0.102	0.112	0.122	
	4W1-2 phase excitation						$\theta = 11/16$		0.084	0.094	0.104	
	4W1-2 phase excitation	2W1-2 phase excitation	W1-2 phase excitation				$\theta = 12/16$		0.066	0.076	0.086	
	4W1-2 phase excitation						$\theta = 13/16$		0.048	0.058	0.068	
	4W1-2 phase excitation	2W1-2 phase excitation					$\theta = 14/16$		0.030	0.040	0.050	
	4W1-2 phase excitation						$\theta = 15/16$		0.010	0.020	0.030	

Characteristics		Symbol	Test circuit	Test Condition	Min	Typ.	Max	Unit
Output transistor switching characteristics (Design target value)		t_r	7	Design target value Output load $25\ \Omega + 15\ \text{pF}$	—	0.2	—	μs
		t_f			—	0.2	—	
		t_{pLH}		Design target value ENABLE to output	—	1	—	ms
		t_{pHL}			—	0.5	—	
Output leakage current	Upper	I_{OH}	6	VM = 15V	—	—	1	μA
	Lower	I_{OL}			—	—	1	

Note: Relative to the peak current at $\theta = 0$.

Test circuit 1: $V_{IN(H)}$, $V_{IN(L)}$, I_{INH} , I_{INL}

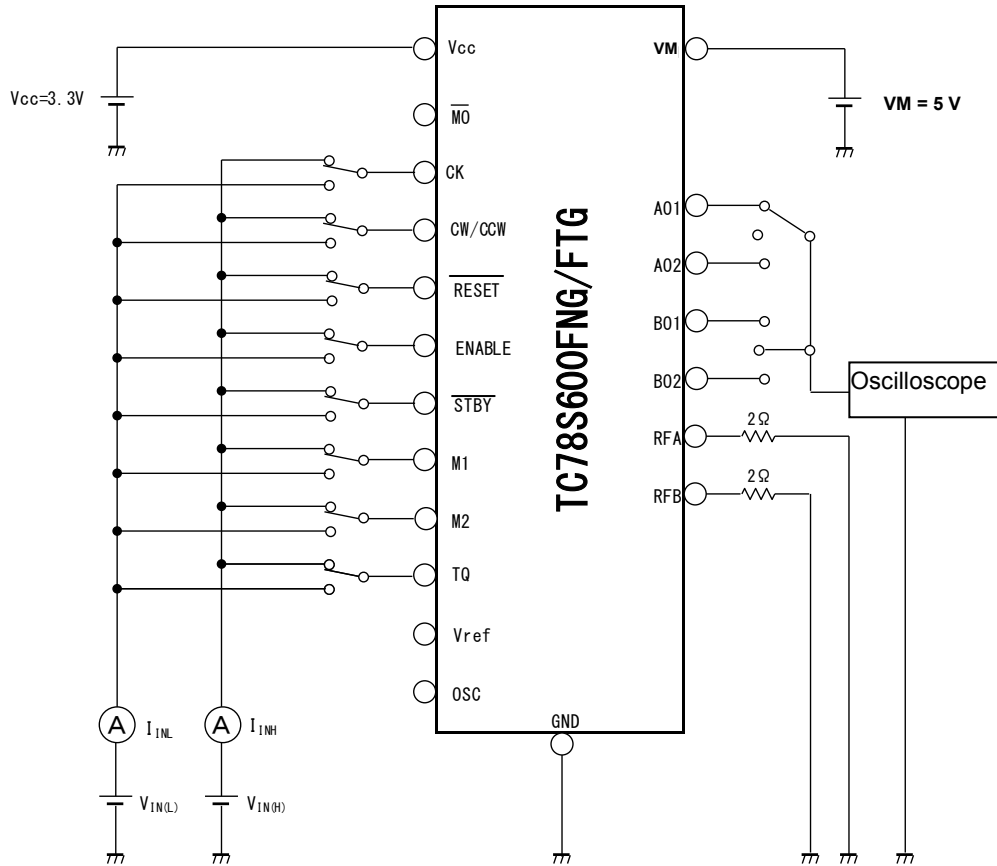

Test circuit 2: I_{CC} , I_M

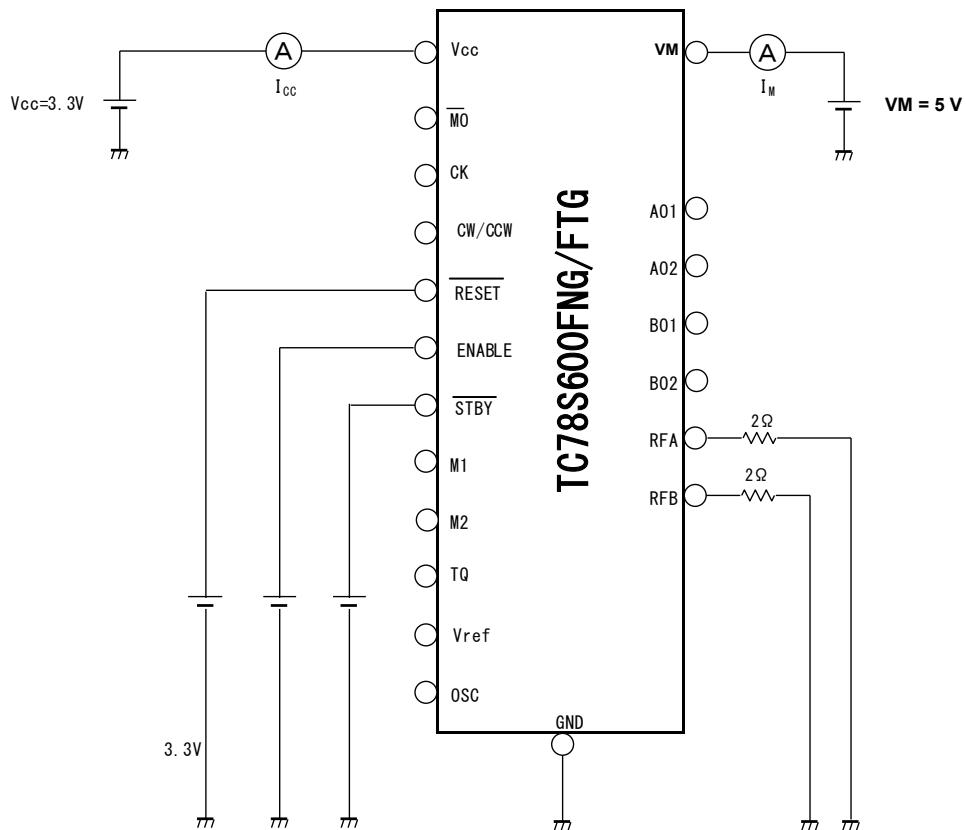

Test circuit 3: V_{RFA} , V_{RFB}

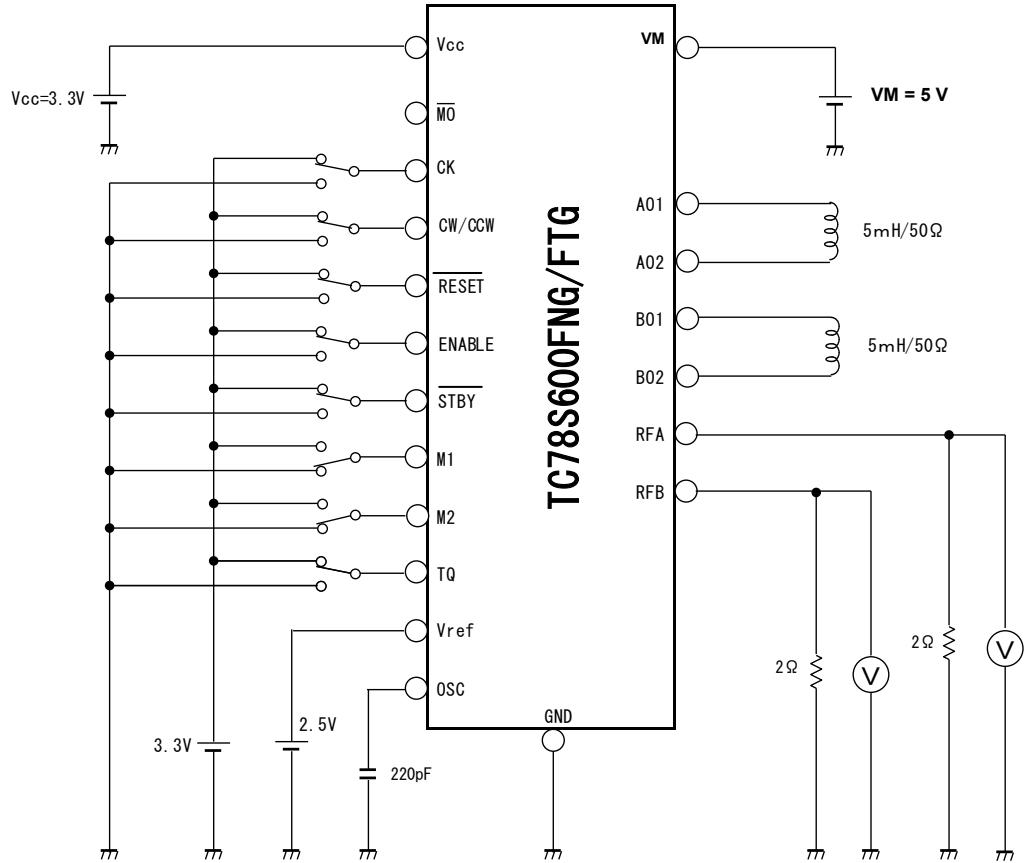

Test circuit 4: $V_{SAT(UL)}$

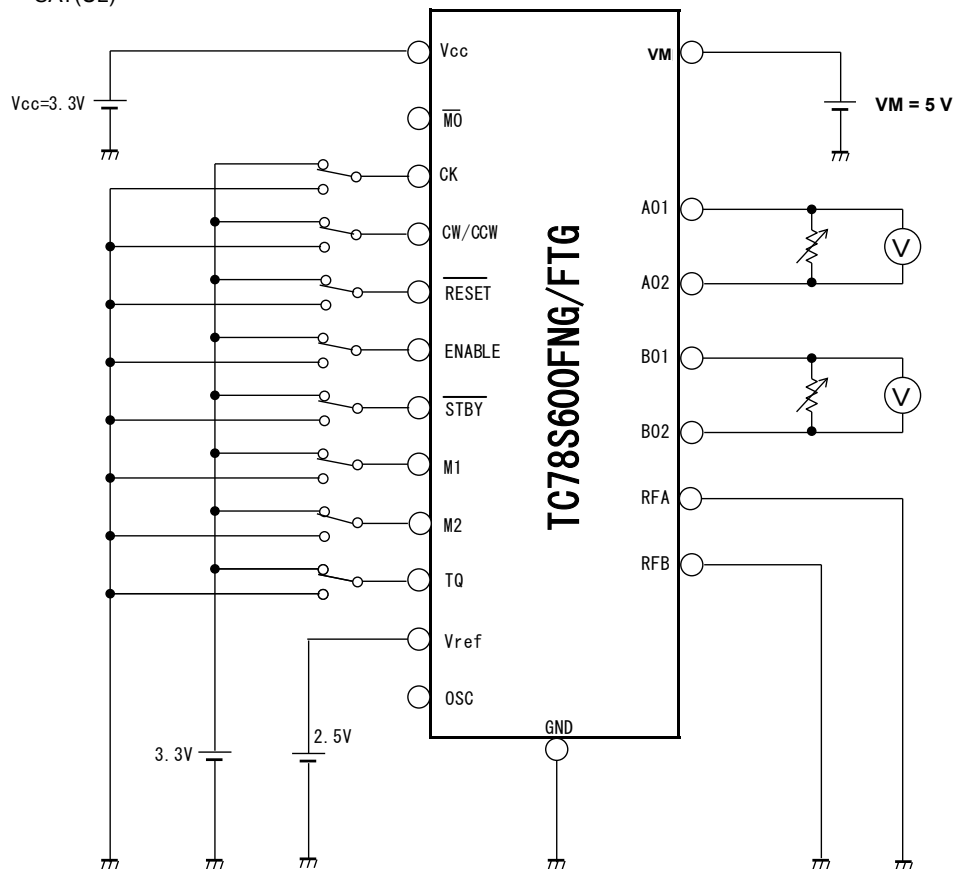

Test circuit 5: V_{FU} , V_{FL}

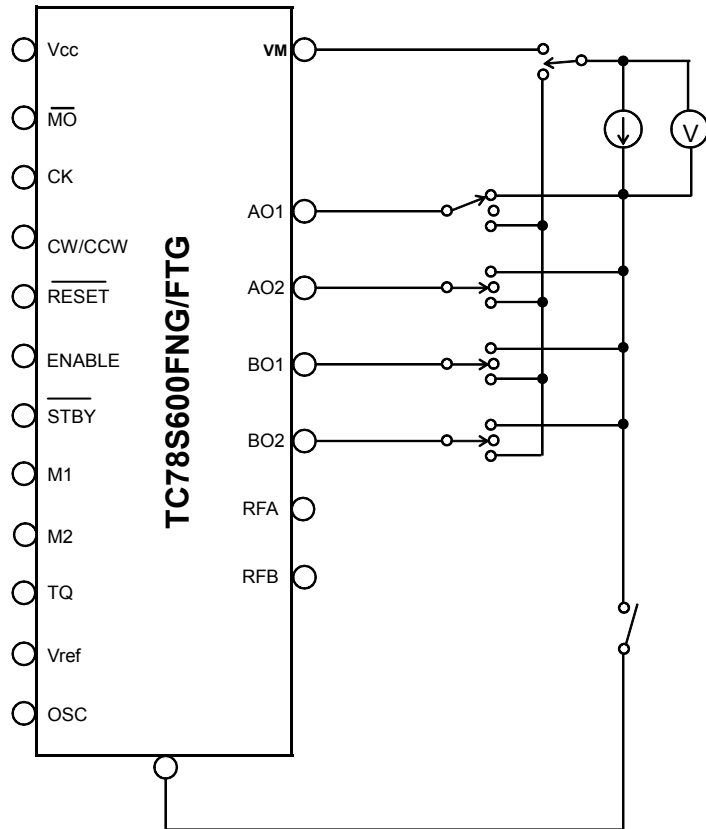

Test circuit 6: I_{OH} , I_{OL}

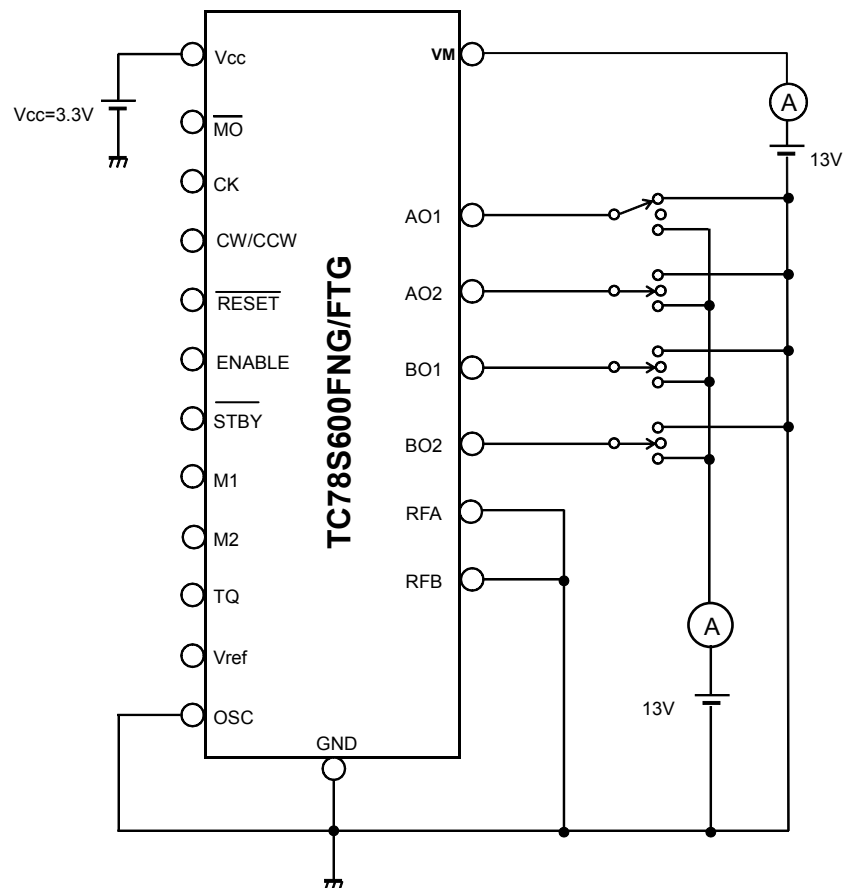

AC electric characteristics Test points 7: CK(OSC)-OUT

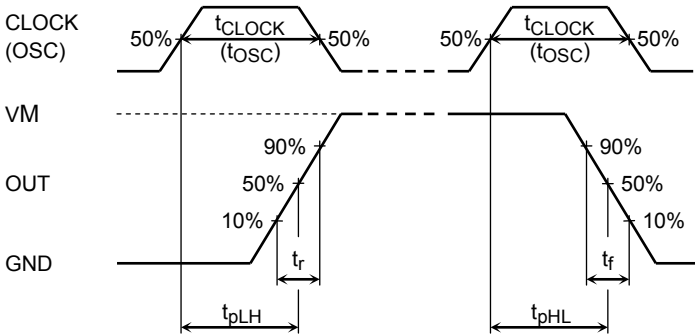

$P_D - T_a$ characteristics

· TC78S600FNG

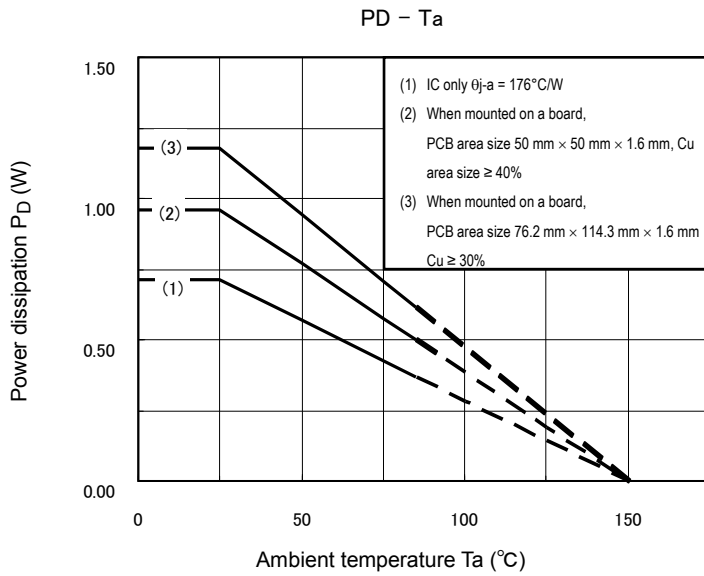

· TC78S600FTG

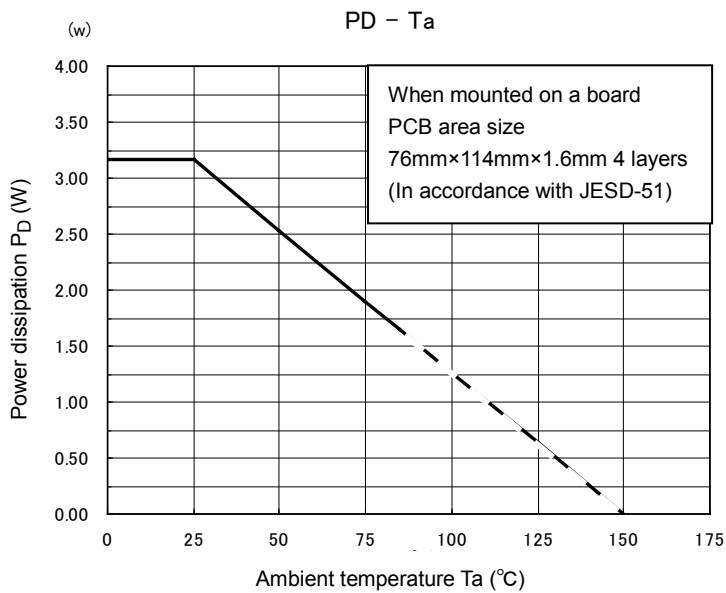

Functional Descriptions

Excitation Mode Settings



Four excitation modes are selectable by setting M1 and M2 terminals.
(4W1-2 phase excitation is default by internal pull-down resistor.)

Input		Excitation mode
M1	M2	
L	L	4W1-2 phase
H	L	1-2 phase
L	H	W1-2 phase
H	H	2W1-2 phase

When excitation mode is shifted, the operation starts from the initial state.

Input Signals and Operation Modes

When ENABLE outputs low, operation of the output block turns off. When $\overline{\text{RESET}}$ terminal outputs low, the mode moves to the initial mode shown below.

CK	CW/CCW	Input			Operation mode
		$\overline{\text{RESET}}$	ENABLE	$\overline{\text{STBY}}$	
	L	H	H	H	CW
	H	H	H	H	CCW
X	X	L	H	H	Initial mode
X	X	X	L	H	Enable standby mode (Output OFF, High impedance)
X	X	X	X	L	Standby mode (Output OFF, High impedance)

X: Don't Care

Initial A- and B-Phase Currents (Initial mode)

Current of each phase in $\overline{\text{RESET}}$ is shown in below table.
In this state, $\overline{\text{MO}}$ terminal outputs low. (Open drain connection)

Excitation Mode	A-Phase Current	B-Phase Current
4W1-2 phase	100%	0%
1-2 phase	100%	0%
W1-2 phase	100%	0%
2W1-2 phase	100%	0%

In this specification, the directions of the current flowing from AO1 to AO2 and from BO1 to BO2 are defined as the forward direction.

Torque Settings

The current ratio of actual operation to the current setting value determined by the resistance is decided. Weak excitation mode can be set when torque is set low (stop mode). TQ1 and TQ2 are connected with pull-down resistance in the IC. So, it is set 25 % in case there is no external input.

Input TQ	Voltage ratio
L	25%
H	100%

Formula of Setting Current

In constant current operation, the reference current should be set by the external resistance. When the voltage of RFA and RFB terminals is $1/5 \times V_{ref}$ (V) (for example, $1/5 \times V_{ref} = 0.5 \text{ V} @ V_{ref} = 2.5 \text{ V}$) or more, charge stops and the current of reference value or more does not flow.

$$I_{OUT} \text{ (A)} = 1/5 \times V_{ref} \text{ (V)} / R_{NF} \text{ (\Omega)} \text{ (When torque is 100 \%.)}$$

Ex.) When the torque is 100 %, V_{ref} is 2.5V, and the maximum current is 0.5 A, the external resistance is 1.0Ω. Then, torque changes to 25 % under the same condition, the maximum current becomes 0.125 A.

V_{ref} should be set between 0.5V to 3.4V. (There is a limitation depending on the conditions, so refer to the operating conditions in page 5). The accuracy becomes low when V_{ref} is less than 0.5V. The recommended resistance is 0.25Ω to 1Ω.

\overline{MO} (Output terminal)

Output terminal has an open drain connection. Pull-up resistance is connected in using. \overline{MO} terminal turns on and outputs low when it is resumed to the specified state.

Pin state	\overline{MO}
Low	Initial state
Z	Not initial state

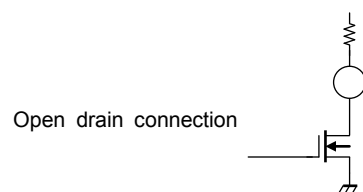

The rest voltage of the \overline{MO} (output terminal) becomes 0.5 V(max.) when I_O is 1 mA.

OSC

Triangle wave is generated internally by connecting the external capacitor to OSC terminal and CR oscillates.

$$C_{osc} 180 \text{ pF} \leq C_{osc} \leq 260 \text{ pF}$$

The system should be constructed with the circuits whose variation is 10 % or less.

Relationship between the ENABLE Input and the Phase Current and \overline{MO} Outputs)

Setting the ENABLE signal Low disables only the output signals. On the other hand, internal logic functions continue to operate in accordance with the CK signal.

Therefore, when the ENABLE signal goes High again, the output current generation is restarted as if phases proceeded with the CK signal.

Example 1. 1-2 phase excitation (M1: H, M2: L)

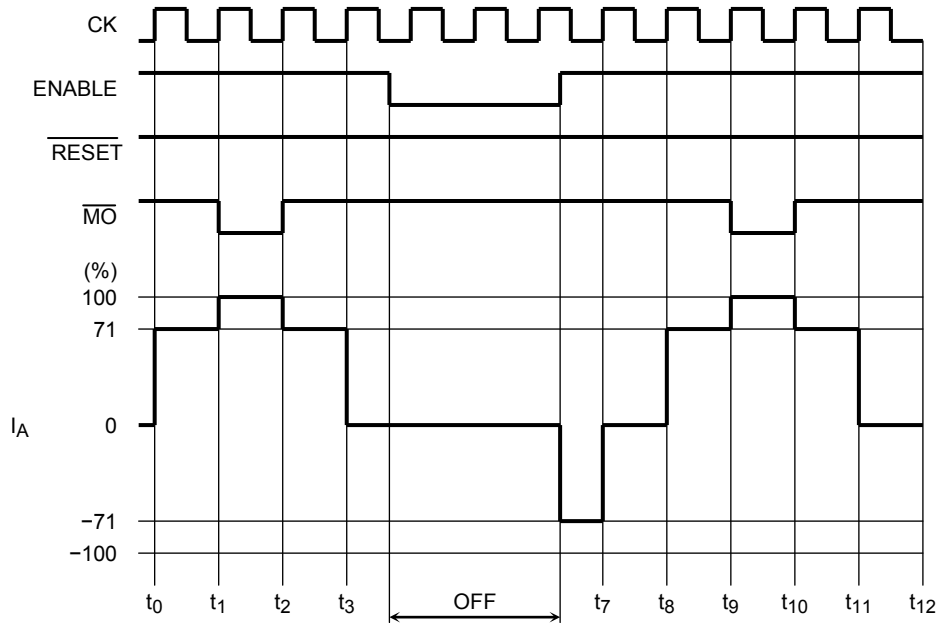

Example 2. 2W1-2 phase excitation (M1: H, M2: H)

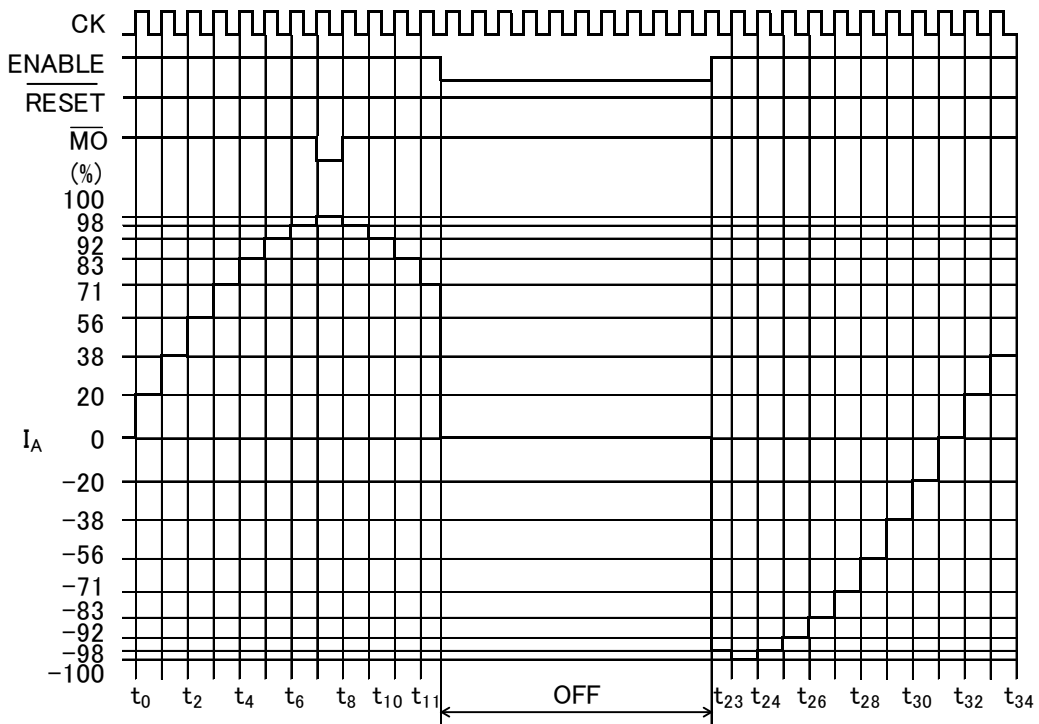

Relationship between the $\overline{\text{RESET}}$ Input and the Phase Current and $\overline{\text{MO}}$ Outputs

Setting the $\overline{\text{RESET}}$ signal Low causes the outputs to be put in the Initial state and the $\overline{\text{MO}}$ output to be Low. (Initial state: A-channel output current is at its peak (100%).) When the $\overline{\text{RESET}}$ signal goes High again, the output current generation is resumed at the next rising edge of the CK signal with the state following the Initial state. If $\overline{\text{RESET}}$ goes High when CK is already High, the output current generation is resumed immediately without waiting for the next rising edge of CK with the state following the Initial state.

Example 1. 1-2 phase excitation (M1: H, M2: L)

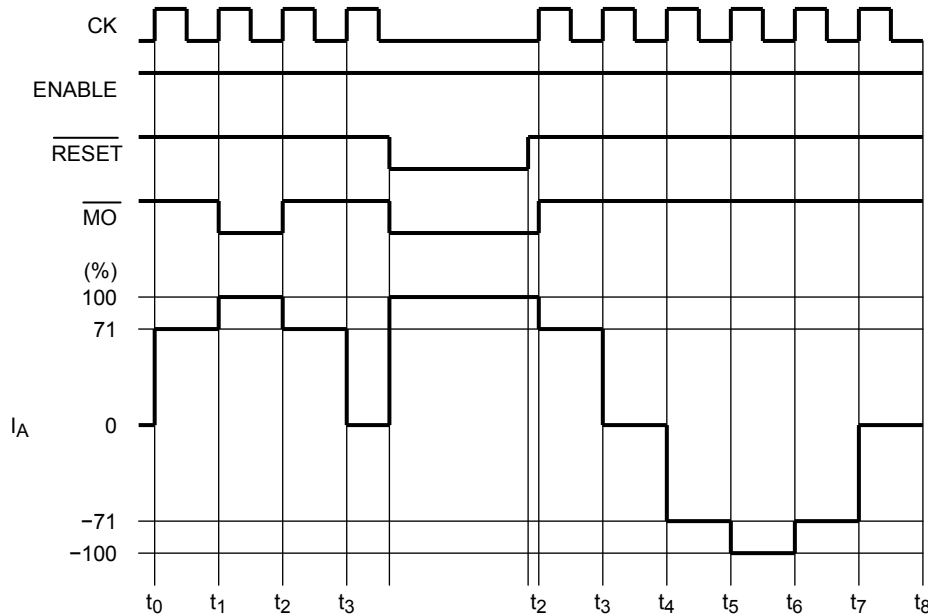

Example 2. 2W1-2 phase excitation (M1: H, M2: H)

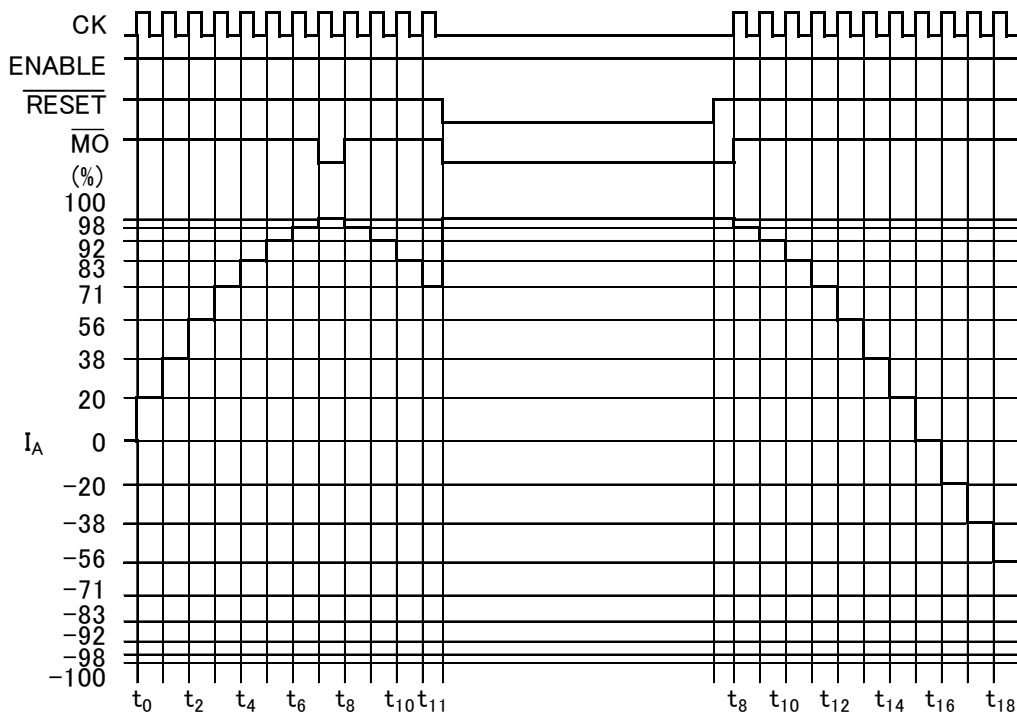

1-2 phase excitation (M1: H, M2: L, CW mode)

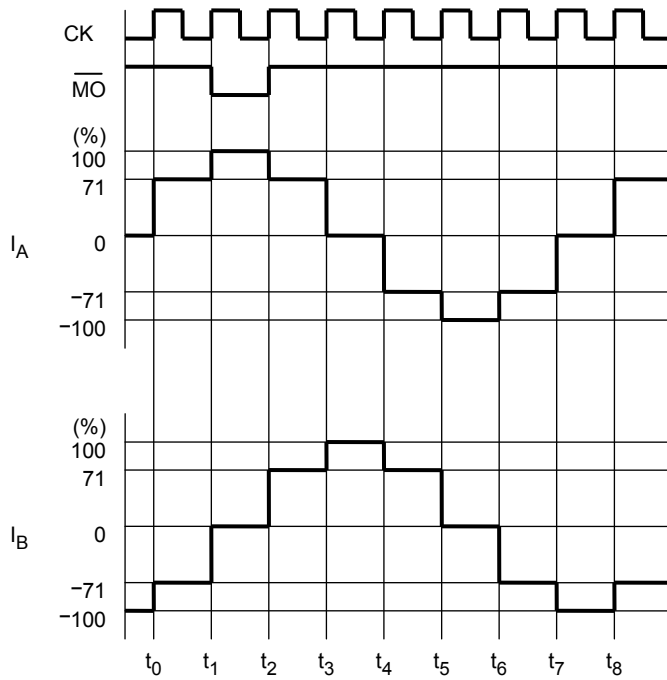

1-2 phase excitation (M1: H, M2: L, CCW mode)

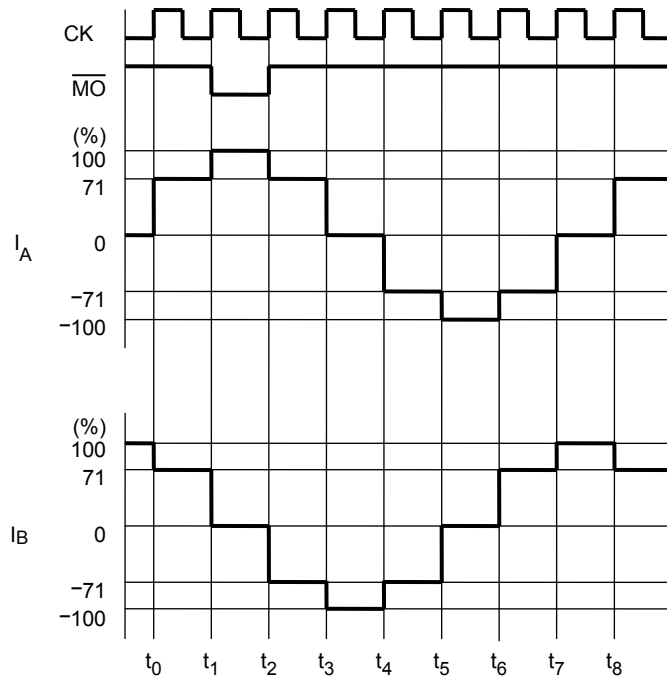

W1-2 phase excitation (M1: L, M2: H, CW mode)

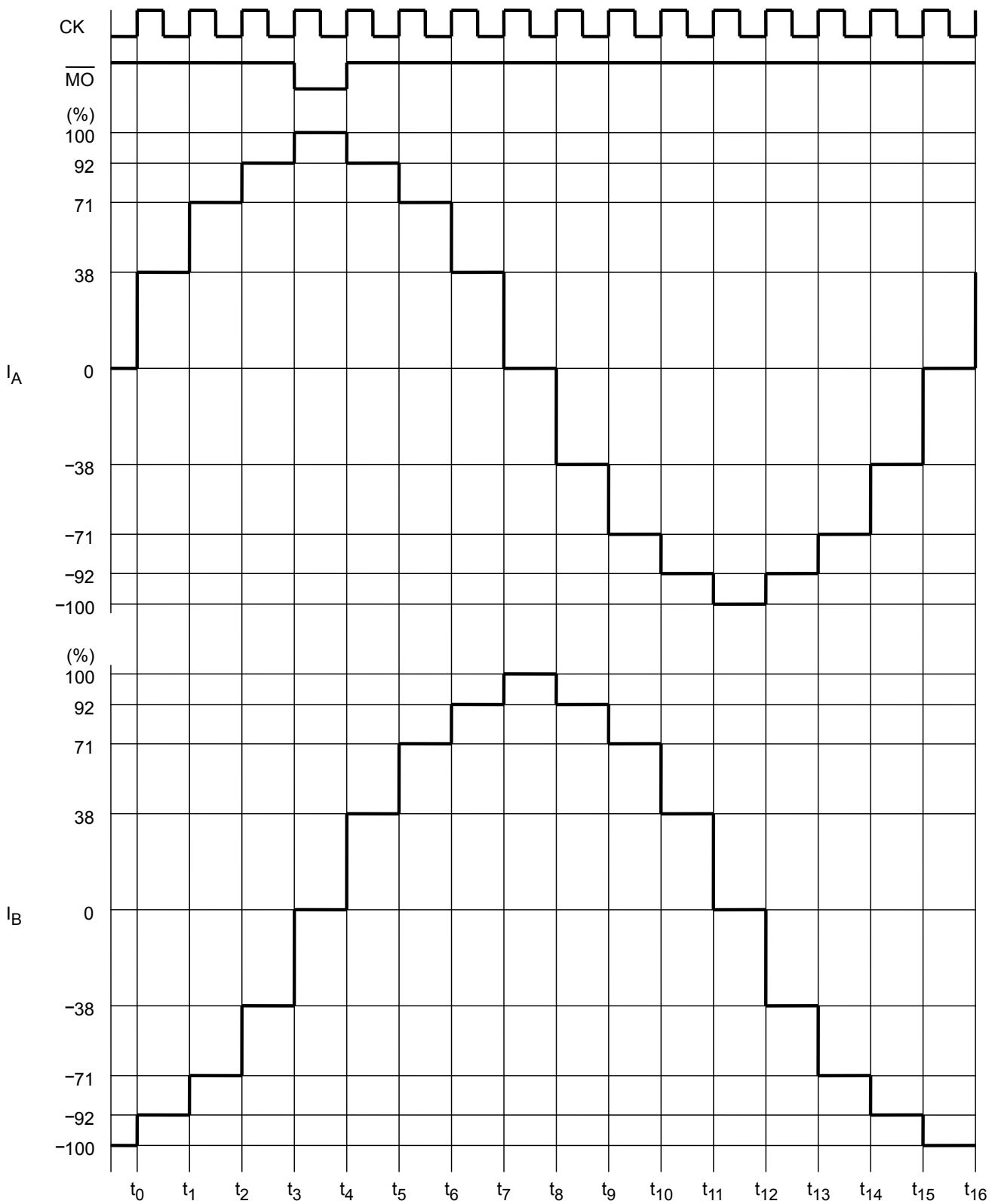

W1-2 phase excitation (M1: L, M2: H, CCW mode)

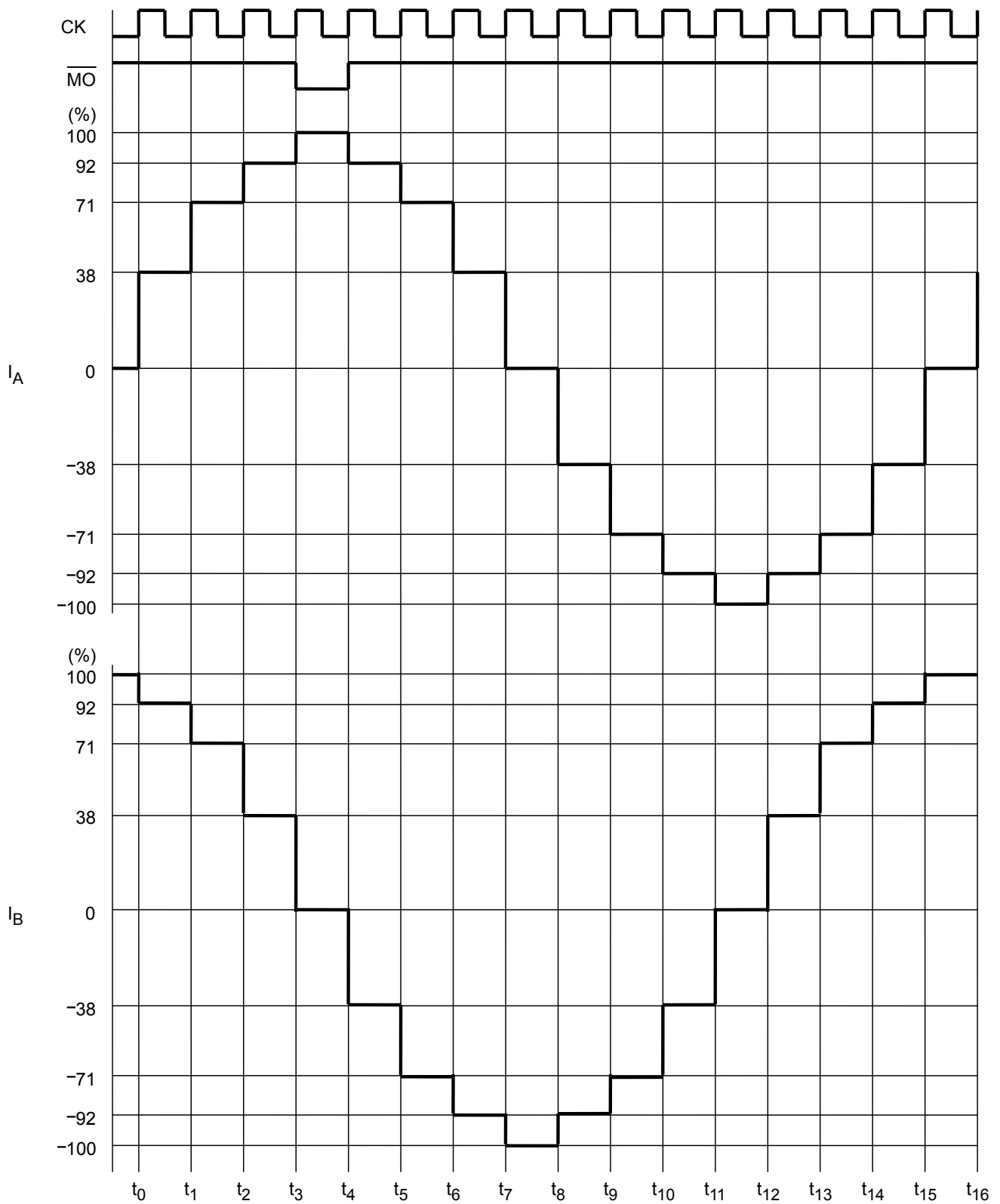

2W1-2 phase excitation (M1: H, M2: H, CW mode)

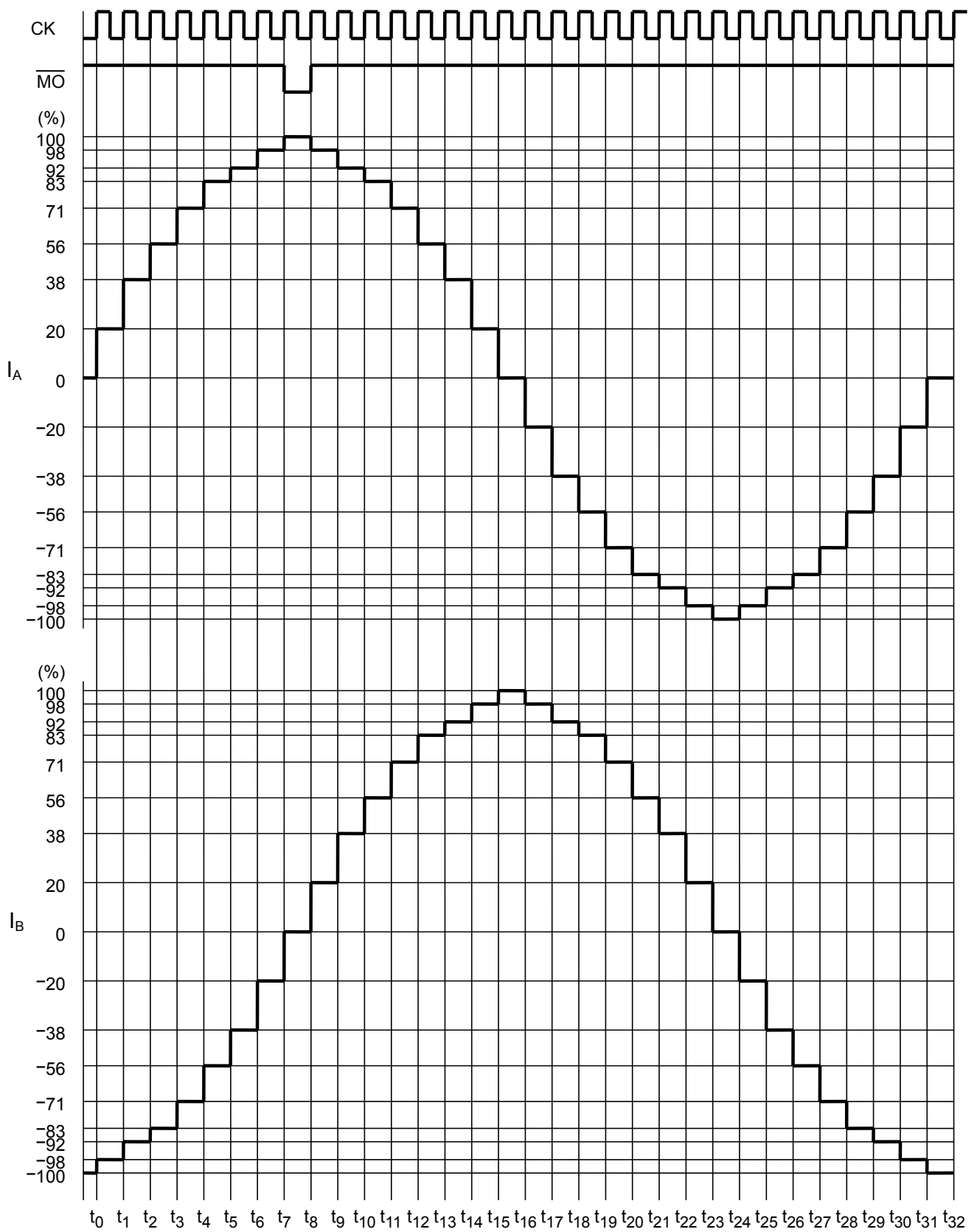

2W1-2 phase excitation (M1: H, M2: H, CCW mode)

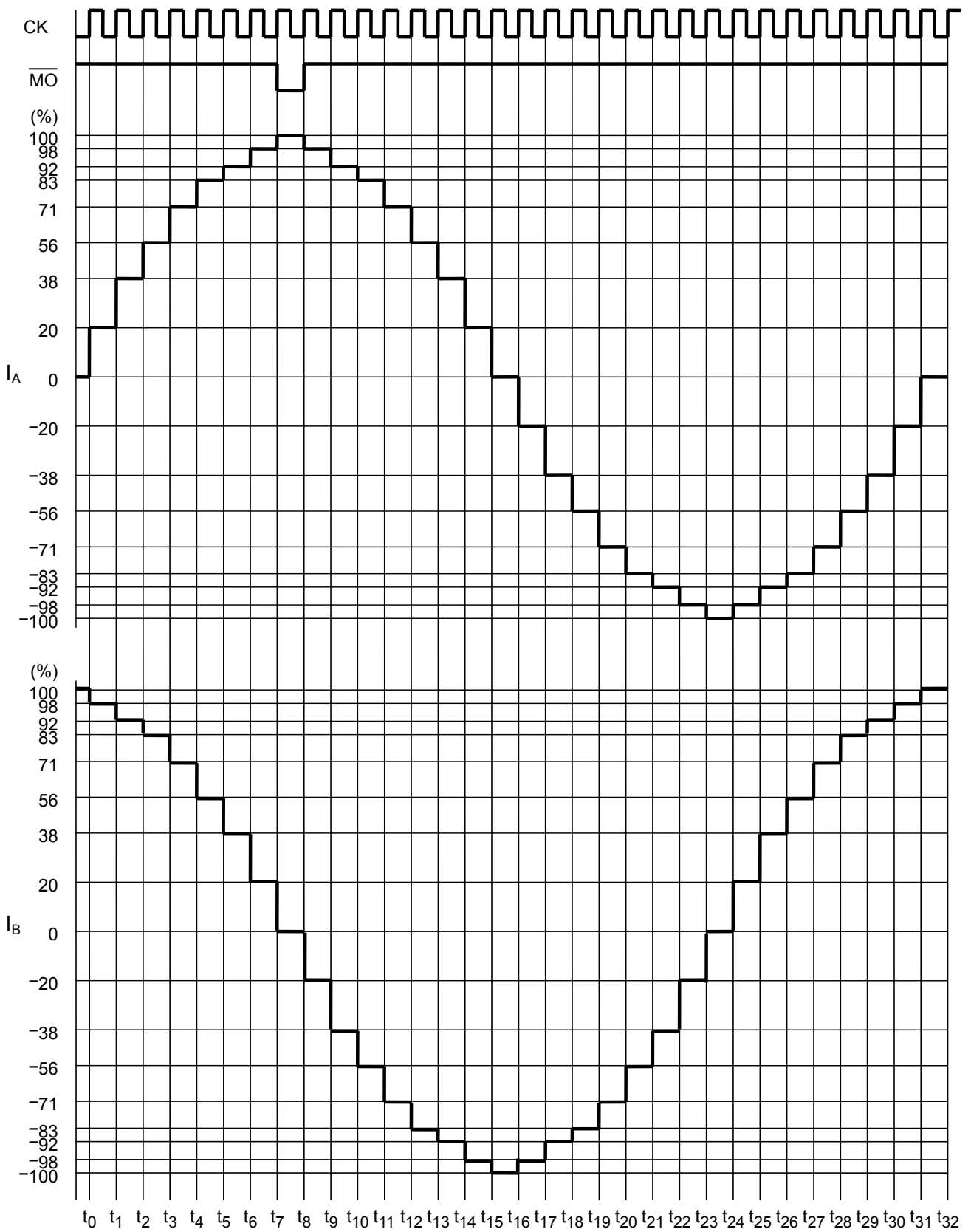

4W1-2 phase excitation (M1: L, M2: L, CW mode)

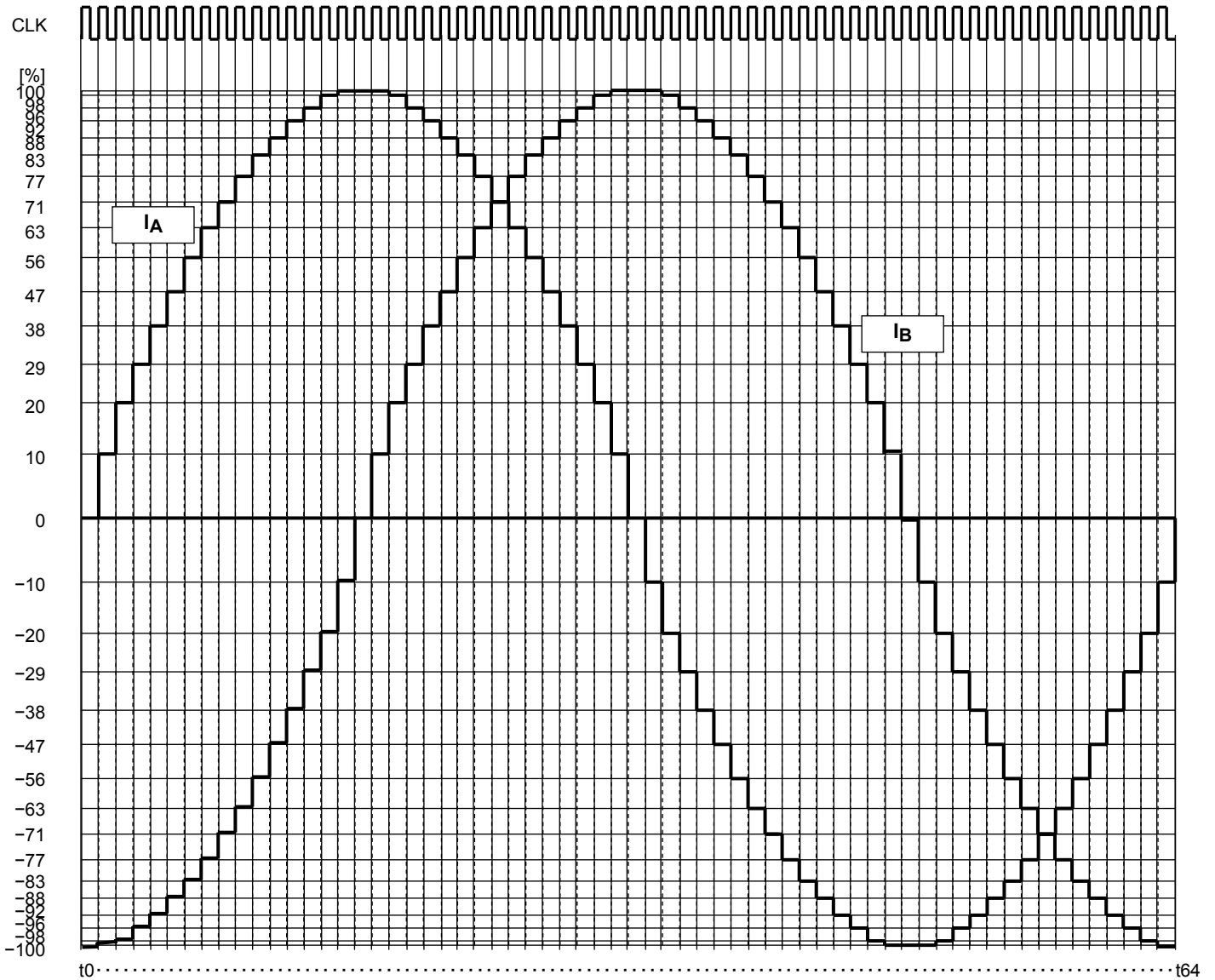

4W1-2 phase excitation (M1: L, M2: L, CCW mode)

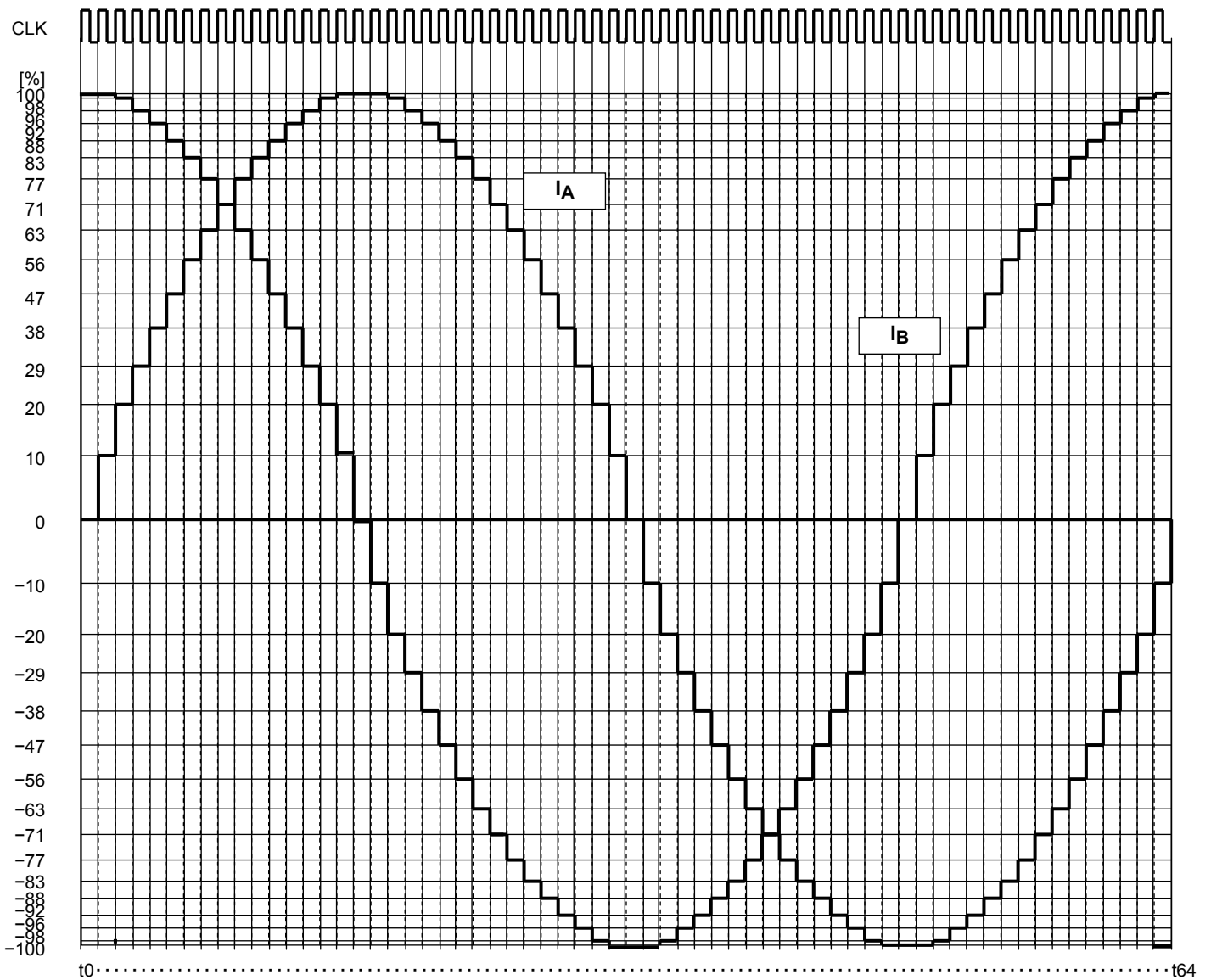

Current level (Unit: %)

Step	4W1-2 phase		2W1-2 phase		W1-2 phase		1-2 phase	
	A phase	B phase	A phase	B phase	A phase	B phase	A phase	B phase
θ 0	100	0	100	0	100	0	100	0
θ 1	100	10						
θ 2	98	20	98	20				
θ 3	96	29						
θ 4	92	38	92	38	92	38		
θ 5	88	47						
θ 6	83	56	83	56				
θ 7	77	63						
θ 8	71	71	71	71	71	71	71	71
θ 9	63	77						
θ 10	56	83	56	83				
θ 11	47	88						
θ 12	38	92	38	92	38	92		
θ 13	29	96						
θ 14	20	98	20	98				
θ 15	10	100						
θ 16	0	100	0	100	0	100	0	100

<Example of input signal>

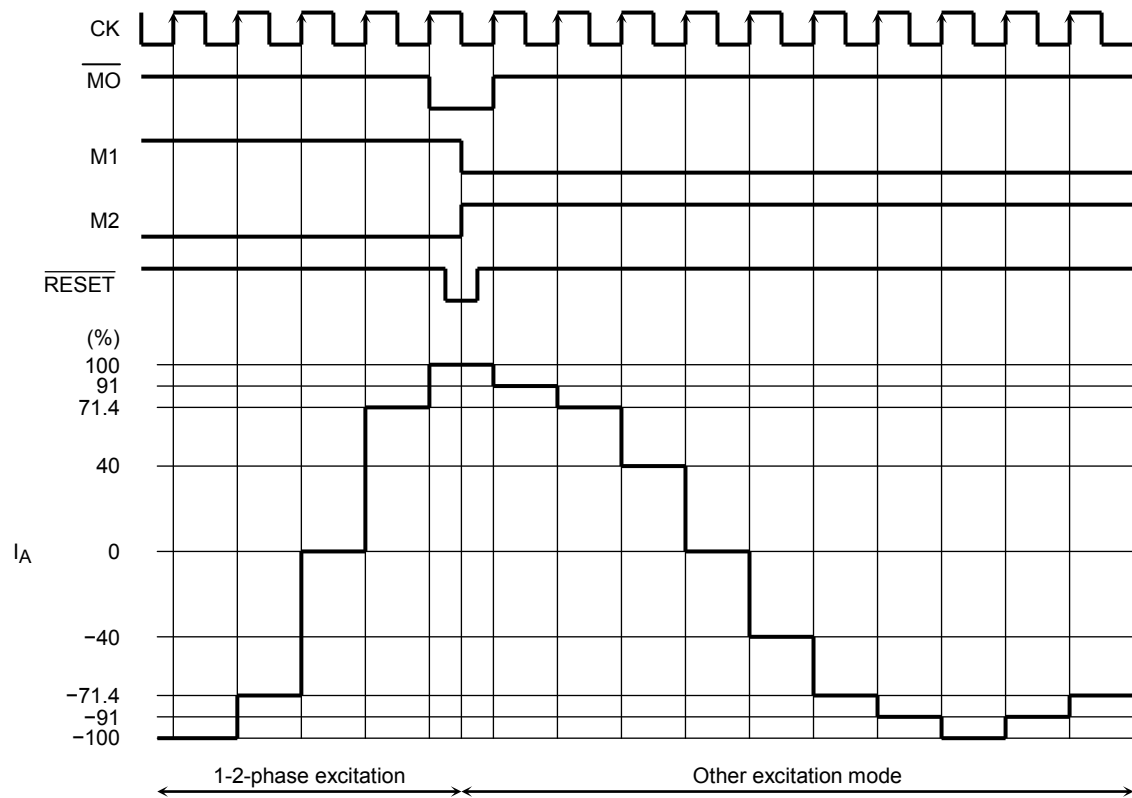

M1 and M2 should be changed after $\overline{\text{RESET}}$ is set low in the initial state ($\overline{\text{MO}} = \text{Low}$). Smooth current waveform cannot be gained if they are changed without setting $\overline{\text{RESET}}$ low though $\overline{\text{MO}}$ is set low.

Decay mode

Fast decay mode is fixed to 12.5%. Cycle of charge and discharge of PWM drive corresponds to 8 cycles of OCS. Last 1 cycles of OCS are decayed in Fast mode.

1. Current waveform and setting of MIXED DECAY MODE

Cycle of charge and discharge of PWM drive corresponds to 8 cycles of OSC.

DECAY MODE is fixed to Fast decay mode of 12.5%.

NF means the point where the output current reaches the setting current.

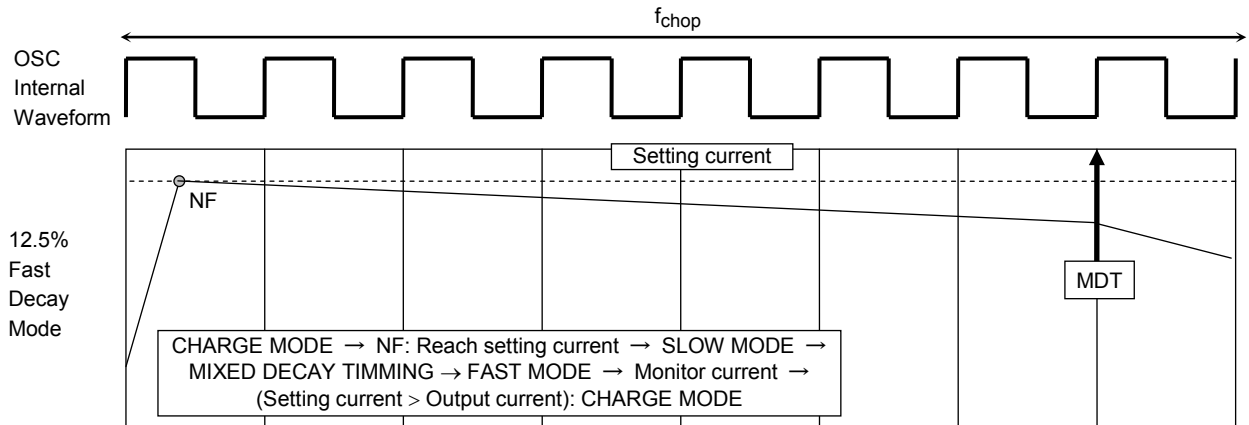

2. Each current control mode (Efficiency of DECAY MODE)

• Increasing current (Sine-wave drive)

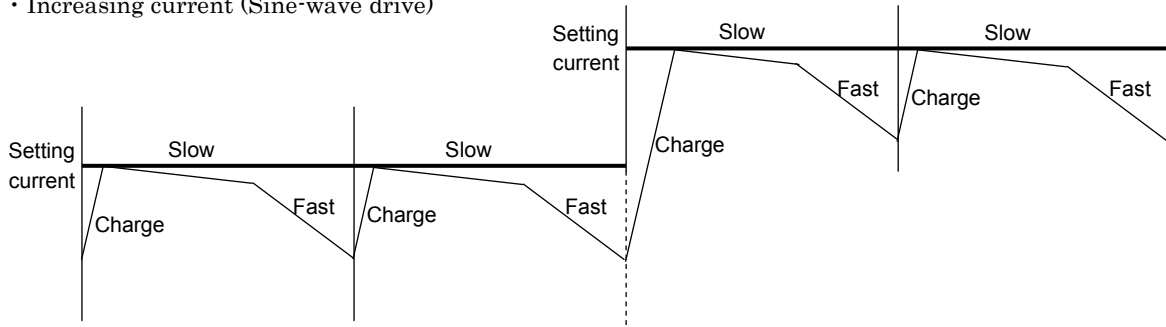

• Decreasing current (Example 1)

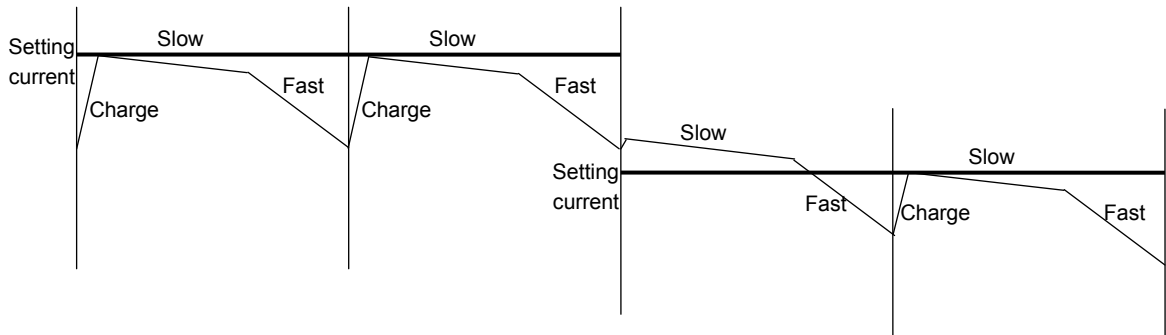

• Decreasing current (Example 2)

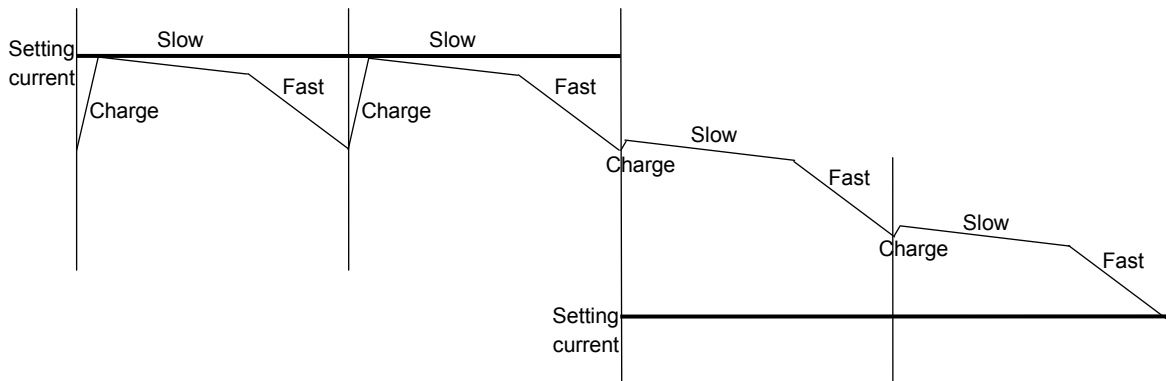

In MIXED DECAY MODE and FAST DECAY MODE, when output current is higher than setting current, CHARGE MODE does not exist (in a narrow sense, CHARGE MODE is very short time for detecting current) at the next chopping cycle. And it moves to SLOW and FAST MODE. SLOW MODE is moved to FAST MODE by MDT.

Note: The figure above is an image. It is a transient response curve in actual.

3. Wave form of MIXED DECAY MODE (Current waveform)

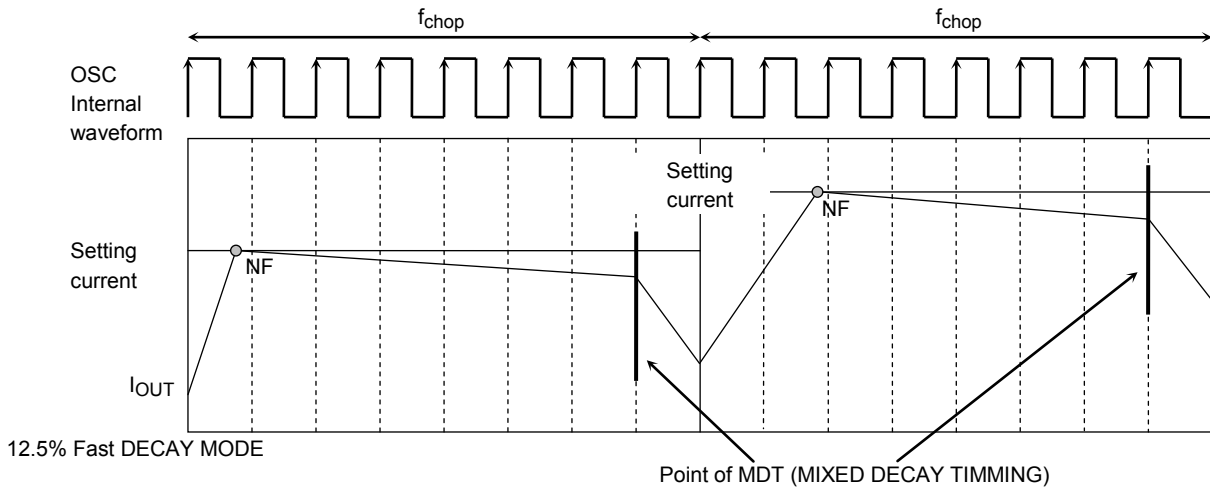

- In case NF point is after MIXED DECAY TIMMING;

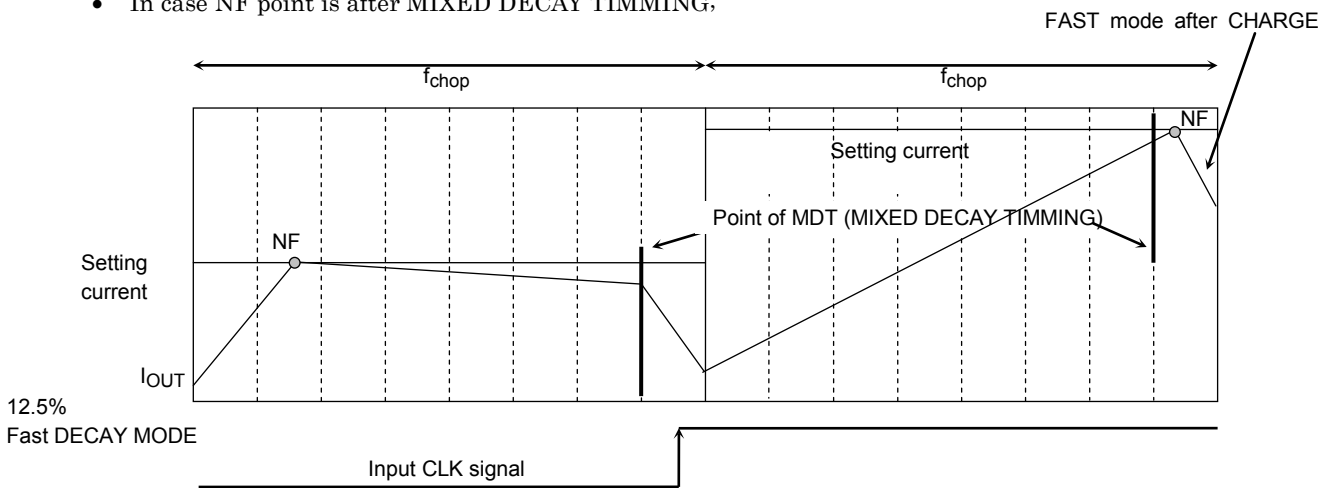

- Output current in MIXED DECAY MODE > Setting current;

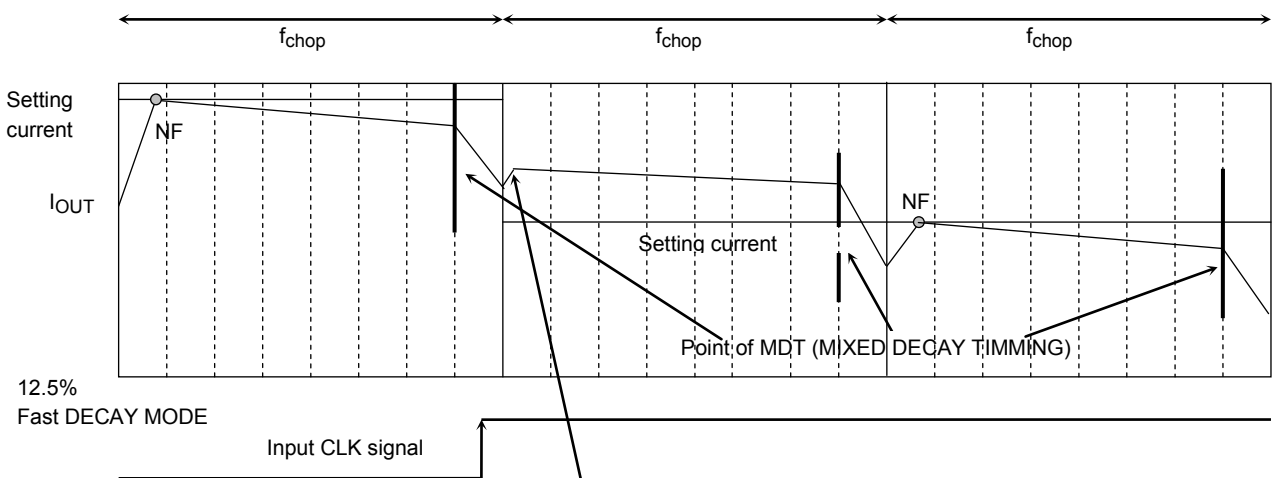

It is charged for a short time for current confirmation though the current is higher than the setting current.

Current pulling path in case Enable is inputted during operation

In Slow Mode, when all output transistors are turned off forcibly, the energy of the coil is pulled in the below mode

- Note: Though parasitic diodes exist on dotted lines, they are not used in the normal MIXED DECAY MODE.

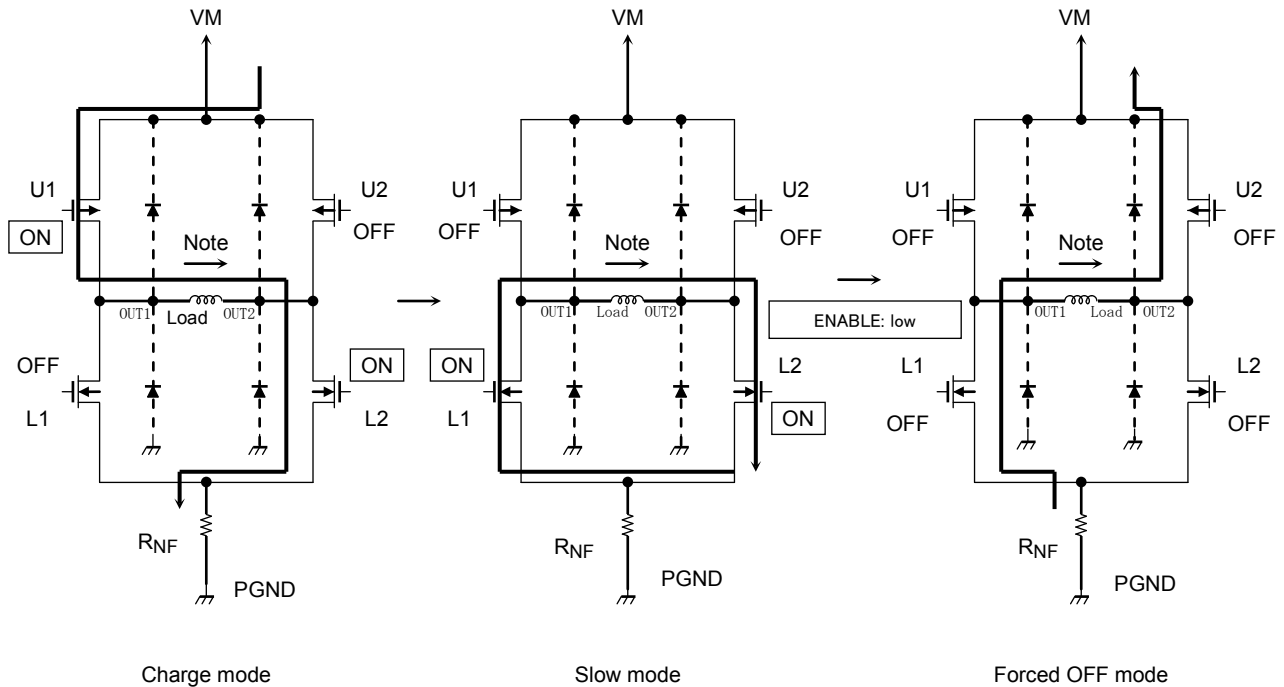

Parasitic diodes exist in the output transistors as shown above.

Parasitic diodes are not used in drawing the energy of the coil because each transistor turns on and current flows in opposite direction. However, when all output transistors are turned off forcibly, the energy of the coil is drawn through the parasitic diodes.

Transistor operation of output

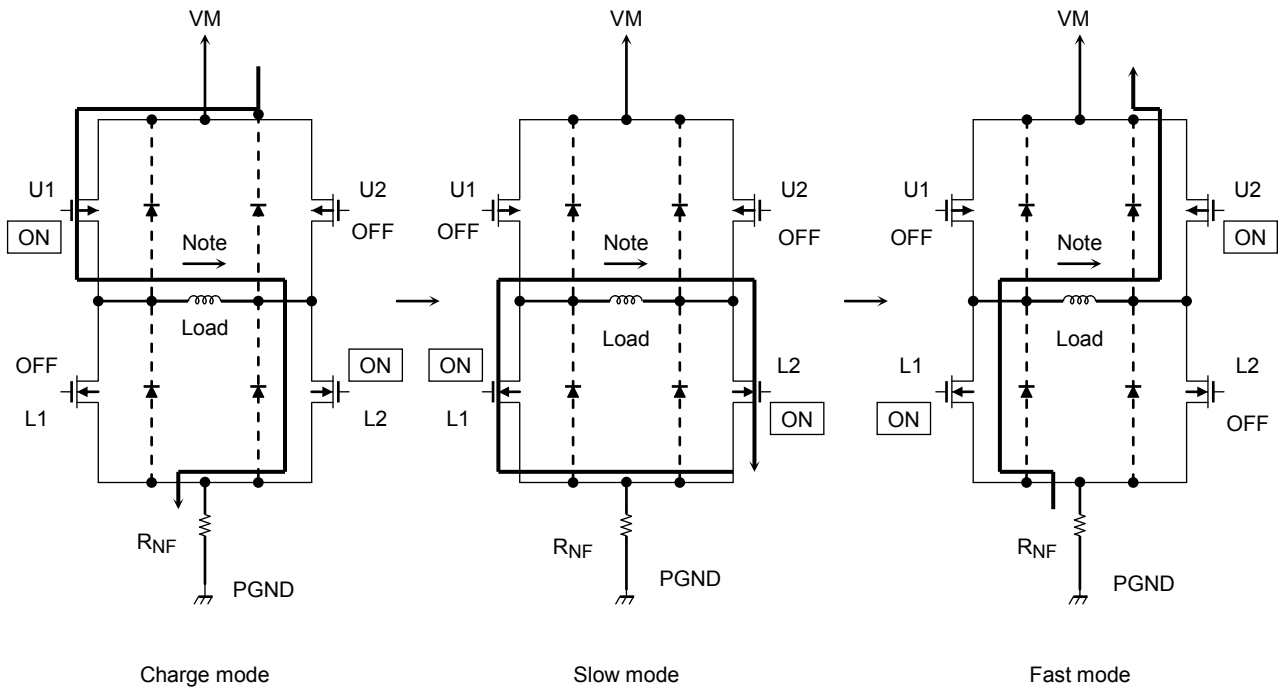

Function of output transistor

CLK	U1	U2	L1	L2
Charge	ON	OFF	OFF	ON
Slow	OFF	OFF	ON	ON
Fast	OFF	ON	ON	OFF

Note: Above table is in the case of applying the current in the direction of an arrow in the above figure. The case of the opposite direction is shown in the below table.

CLK	U1	U2	L1	L2
Charge	OFF	ON	ON	OFF
Slow	OFF	OFF	ON	ON
Fast	ON	OFF	OFF	ON

In moving the function above, each dead time of about 300 ns is inserted.

Thermal shut down (TSD) circuit

The TC78S600FNG/FTG includes a thermal shutdown circuit, which turns the output transistors off when the junction temperature (T_j) exceeds 170°C (typ.).

The output transistors are automatically turned on when T_j cools past the shutdown threshold, which is lowered by a hysteresis of 40°C .

TSD = 170°C (design target value) (Note)

$\Delta\text{TSD} = 40^{\circ}\text{C}$ (design target value) (Note)

Note: Toshiba does not implement testing before shipping.

*In thermal shutdown mode, the internal circuitry and outputs assume the same states as in enable standby mode. Upon exit from thermal shutdown mode, they revert to those states which they assume when taken out of enable standby mode. Start of the output waveform is not defined. It can start from the initial state by inputting low to the reset.

ISD (Over current protection)

When any of current which flows in 8 DMOS transistors exceeds 1.7 A (typ.), all outputs are turned off. It does not resume automatically but latches. It resumes when ENABLE is set low to high or UVLO operates. When ENABLE is set low to high, the pulse of 0.15ms or more should be recognized.

However, masking term of $4\mu\text{s}$ (typ.) should be added in order to avoid detection error by the noise.

ISD = $1.7\text{A} \pm 0.5\text{A}$ (Note)

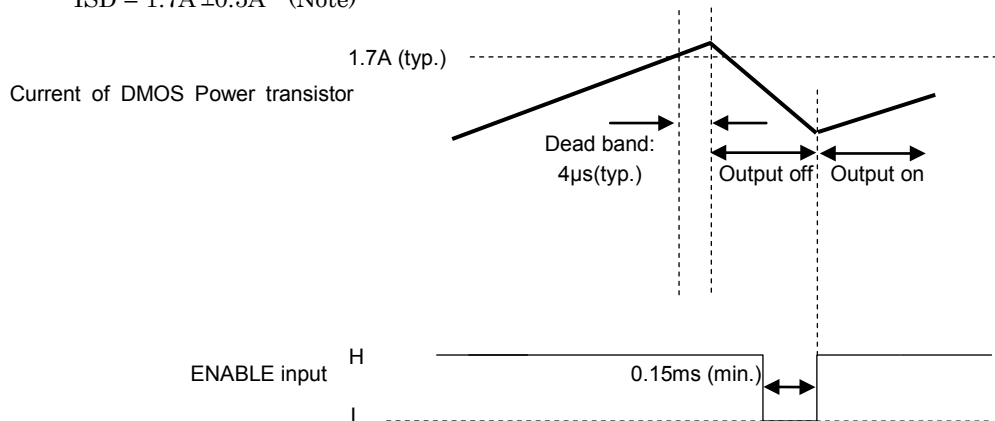

Note: Toshiba does not implement testing before shipping.

The state of internal IC and the output state while ISD function operates are same as that of enable standby mode. Start of the output waveform of automatic recovery can not be defined along with the release from the enable standby mode. It can start from the initial state by setting the reset low.

Under voltage lockout (UVLO) circuit

The TC78S600FNG/FTG includes an undervoltage lockout circuit, which puts the output transistors in the high-impedance state when V_{CC} decreases to 2.2 V (typ.) or lower.

The output transistors are automatically turned on when V_{CC} increases past the lockout threshold, which is raised to 2.3 V (typ.) by a hysteresis of 0.1 V (typ.).

Even when UVLO circuit is tripped, internal circuitry continues to operate in accordance with the CK input like when ENABLE is set Low. Thus, after the TC78S600FNG/FTG exits the UVLO mode, the RESET signal should be asserted for putting the TC78S600FNG/FTG in the Initial state if necessary.

The TC78S600FNG/FTG includes an undervoltage lockout circuit, which puts the output transistors in the high-impedance state when V_M decreases to 2.0 V (typ.) or lower.

The output transistors are automatically turned on when V_M increases past the lockout threshold, which is raised to 2.1 V (typ.) by a hysteresis of 0.1 V (typ.).

Even when UVLO circuit is tripped, internal circuitry continues to operate in accordance with the CK input like when ENABLE is set Low. Thus, after the TC78S600FNG/FTG exits the UVLO mode, the RESET signal should be asserted for putting the TC78S600FNG/FTG in the Initial state if necessary.

State of the internal IC and output state when UVLO function operates are same as that of the enable standby mode. Start of the output waveform of automatic recovery can not be defined along with the release from the enable standby mode. It can start from the initial state by setting the reset low.

Power-on Sequence with Control Input Signals

The order of turning on Vcc and VM is not settled for the user. So, please design the IC not to be damaged even in case of the start-up (or, even in case of shutdown) from either power supply.

In supplying and shutting down the power, there should be no abnormal operations in outputting. Power supply monitoring circuit should be provided in necessary. The IC should not be damaged if the power-on sequence is wrong. The IC should not be damaged in power-on if each input terminal (M1, M2, M3, CLK, CW/CCW, ENABLE, RESET, DCY, and TQ) is high or low, and Vref outputs any value within the operating range.

Two examples are shown below figures.

(Example 1): ENABLE = High → RESET = High

(Example 2): RESET = High → ENABLE = High

Motor can start rotating from the initial state in the Example 1.

(1)CLK: Current steps proceed in every rising edge of CLK.

(2)ENABLE: Low: Output is Hi-Z. High: Outputting.

RESET: Low: Initial state (A phase 100%, B phase 0%).

①ENABLE = Low and RESET = Low: Setting of internal current is initial state though output is Hi-Z.

②ENABLE = Low and RESET = High: Setting of internal current is proceeded by the internal counter though output is Hi-Z.

③ENABLE = High and RESET = Low: Outputting in the initial state (A phase 100%, B phase 0%).

④ENABLE = High and RESET = High: Outputting at the value proceeded by the internal counter.

< Recommended Control Input Sequence >

(Ex.1)

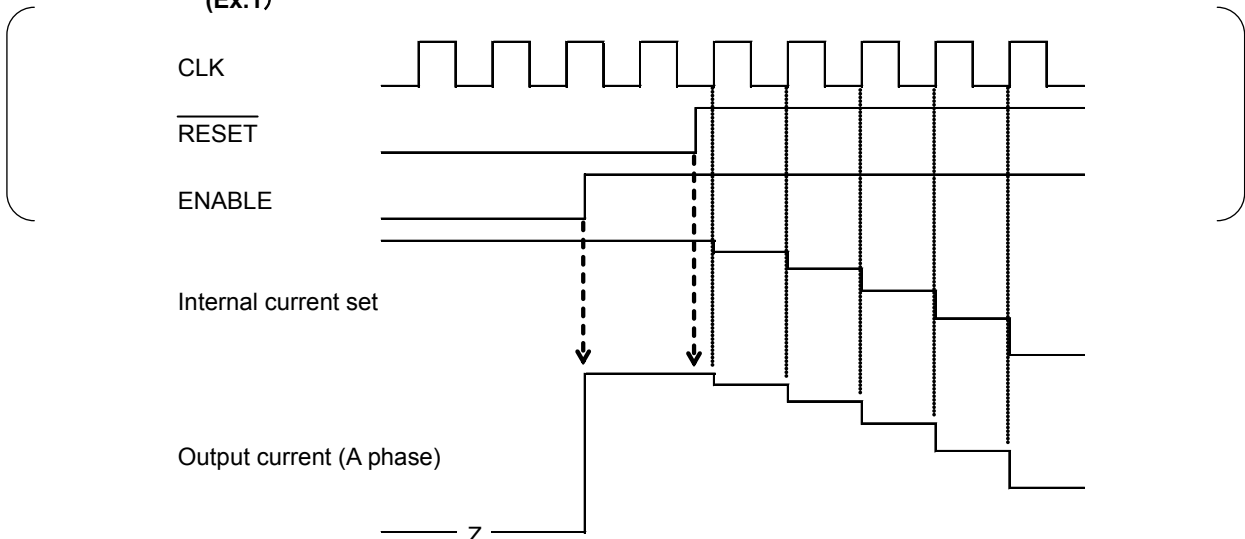

(Ex.2)

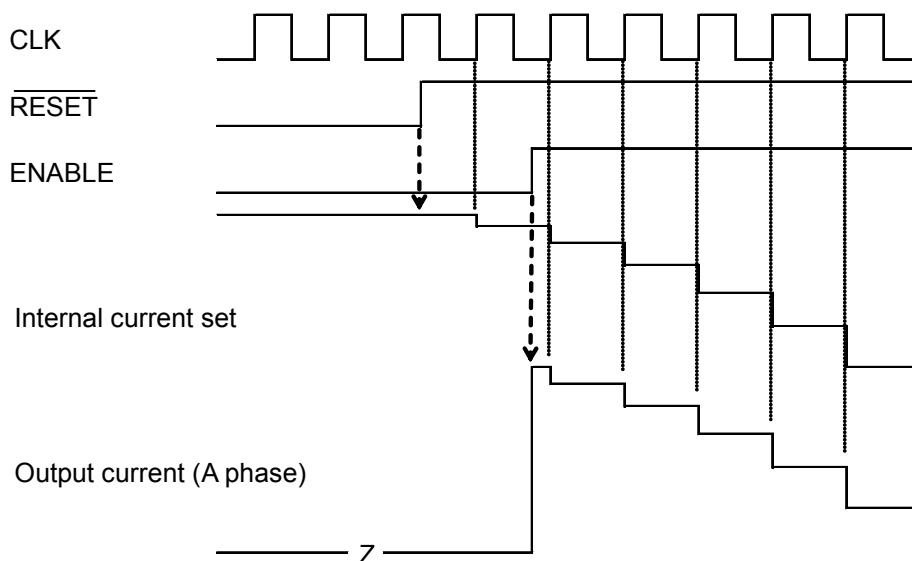

Application Circuit Example

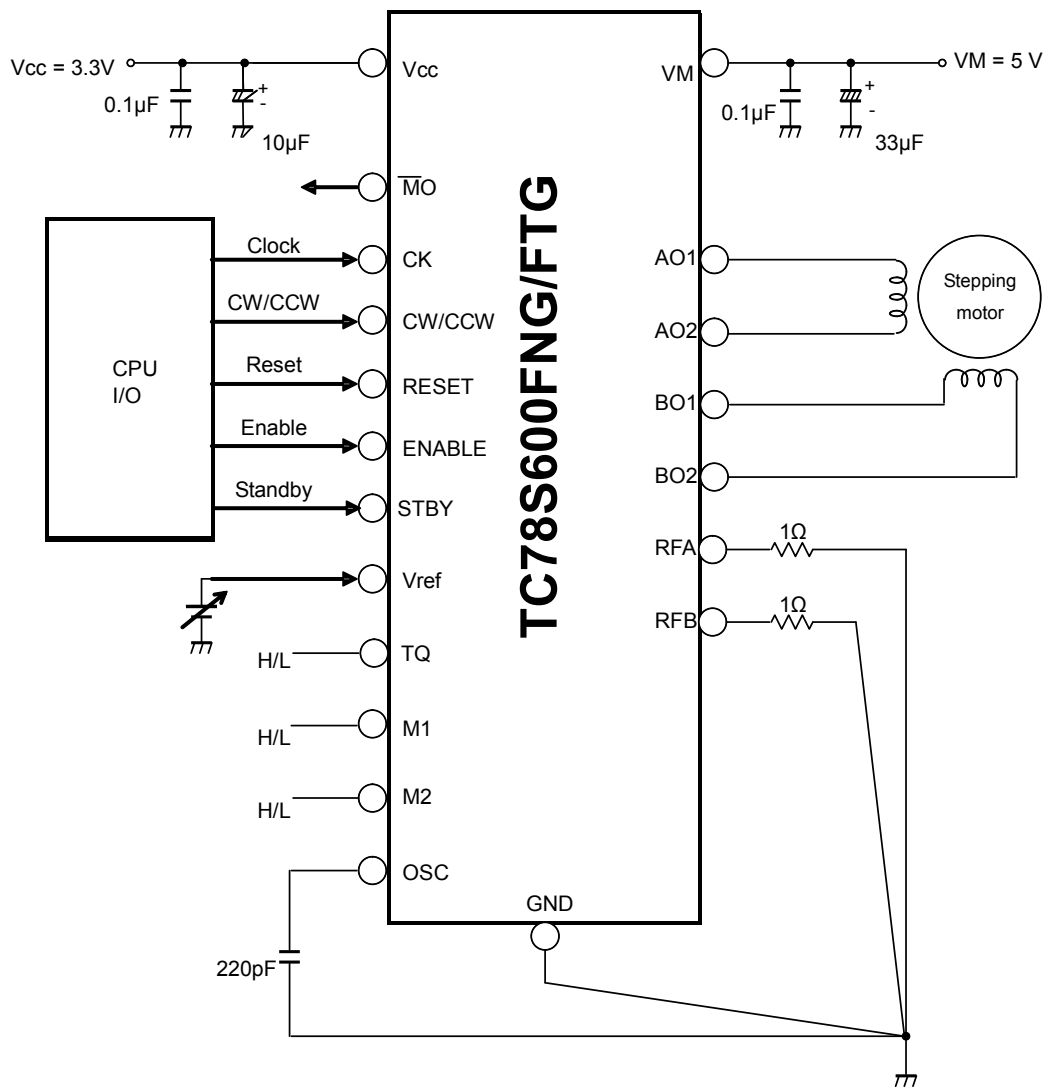

Note 1: Capacitors for the power supply lines should be connected as close to the IC as possible.

Note 2: The ENABLE pin must be set Low upon powering on and off the device. Otherwise, a large current might abruptly flow through the output pins.

Usage Considerations

A large current might abruptly flow through the IC in case of a short-circuit across its outputs, a short-circuit to power supply or a short-circuit to ground, leading to a damage of the IC. Also, the IC or peripheral parts may be permanently damaged or emit smoke or fire resulting in injury especially if a power supply pin (VCC, VM) or an output pin (AO1, AO2, BO1, BO2) is short-circuited to adjacent or any other pins.

These possibilities should be fully considered in the design of the output, VCC, VM and ground lines.

Install this IC correctly. If not, (e.g., installing it in the wrong position,) the IC may be damaged permanently.

Fuses should be connected to the power supply lines.

Package Dimensions

SSOP20-P-225-0.65A

Unit : mm

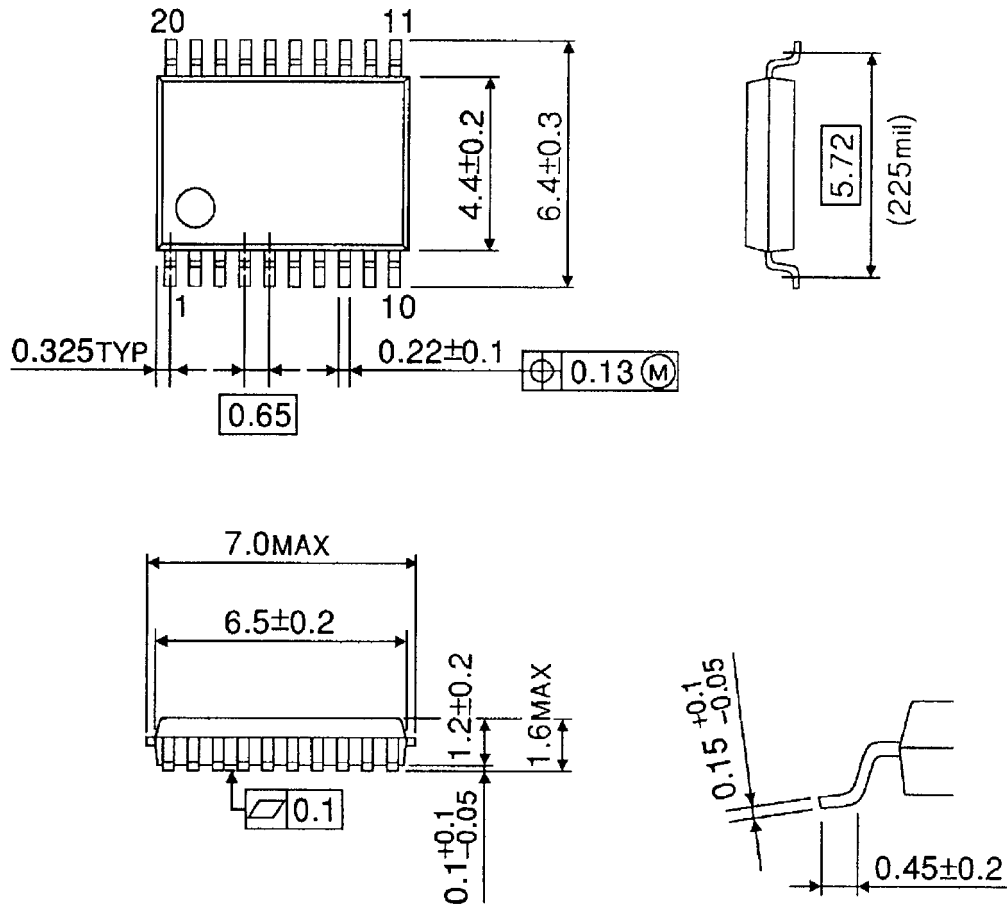

Weight: 0.09g(typ.)

P-WQFN24-0404-0.50-004

Unit: mm

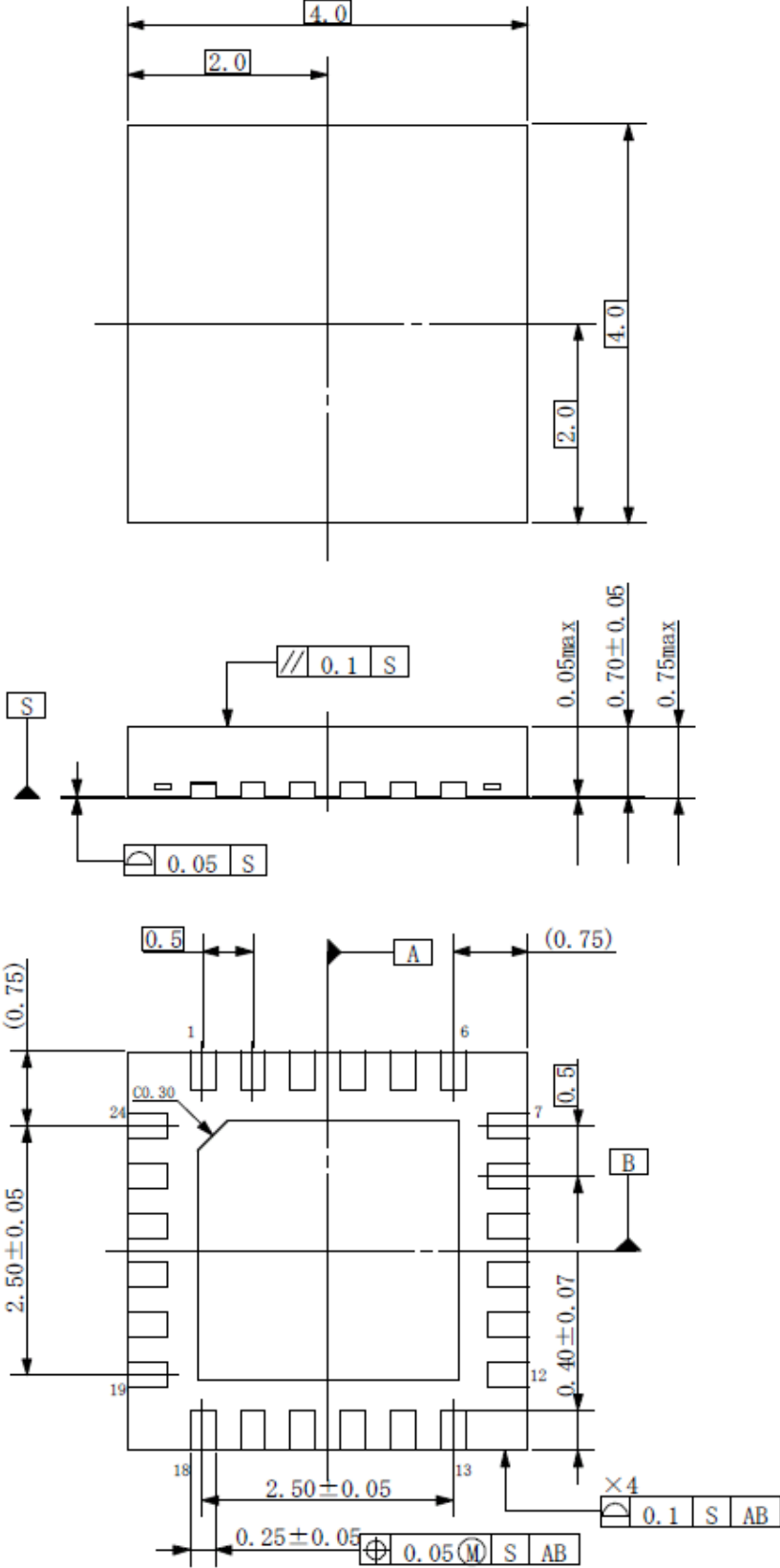

Weight: 0.03g(typ.)

Notes on Contents

1. Block Diagrams

Some of the functional blocks, circuits, or constants in the block diagram may be omitted or simplified for explanatory purposes.

2. Equivalent Circuits

The equivalent circuit diagrams may be simplified or some parts of them may be omitted for explanatory purposes.

3. Timing Charts

Timing charts may be simplified for explanatory purposes.

4. Application Circuits

The application circuits shown in this document are provided for reference purposes only. Thorough evaluation is required, especially at the mass production design stage.

Toshiba does not grant any license to any industrial property rights by providing these examples of application circuits.

5. Test Circuits

Components in the test circuits are used only to obtain and confirm the device characteristics. These components and circuits are not guaranteed to prevent malfunction or failure from occurring in the application equipment.

IC Usage Considerations

Notes on handling of ICs

- [1] The absolute maximum ratings of a semiconductor device are a set of ratings that must not be exceeded, even for a moment. Do not exceed any of these ratings.
Exceeding the rating(s) may cause the device breakdown, damage or deterioration, and may result injury by explosion or combustion.
- [2] Use an appropriate power supply fuse to ensure that a large current does not continuously flow in case of over current and/or IC failure. The IC will fully break down when used under conditions that exceed its absolute maximum ratings, when the wiring is routed improperly or when an abnormal pulse noise occurs from the wiring or load, causing a large current to continuously flow and the breakdown can lead smoke or ignition. To minimize the effects of the flow of a large current in case of breakdown, appropriate settings, such as fuse capacity, fusing time and insertion circuit location, are required.
- [3] If your design includes an inductive load such as a motor coil, incorporate a protection circuit into the design to prevent device malfunction or breakdown caused by the current resulting from the inrush current at power ON or the negative current resulting from the back electromotive force at power OFF. IC breakdown may cause injury, smoke or ignition.
Use a stable power supply with ICs with built-in protection functions. If the power supply is unstable, the protection function may not operate, causing IC breakdown. IC breakdown may cause injury, smoke or ignition.
- [4] Do not insert devices in the wrong orientation or incorrectly.
Make sure that the positive and negative terminals of power supplies are connected properly.
Otherwise, the current or power consumption may exceed the absolute maximum rating, and exceeding the rating(s) may cause the device breakdown, damage or deterioration, and may result injury by explosion or combustion.
In addition, do not use any device that is applied the current with inserting in the wrong orientation or incorrectly even just one time.

Points to remember on handling of ICs**(1) Over current Protection Circuit**

Over current protection circuits (referred to as current limiter circuits) do not necessarily protect ICs under all circumstances. If the over current protection circuits operate against the over current, clear the over current status immediately.

Depending on the method of use and usage conditions, such as exceeding absolute maximum ratings can cause the over current protection circuit to not operate properly or IC breakdown before operation. In addition, depending on the method of use and usage conditions, if over current continues to flow for a long time after operation, the IC may generate heat resulting in breakdown.

(2) Thermal Shutdown Circuit

Thermal shutdown circuits do not necessarily protect ICs under all circumstances. If the thermal shutdown circuits operate against the over temperature, clear the heat generation status immediately.

Depending on the method of use and usage conditions, such as exceeding absolute maximum ratings can cause the thermal shutdown circuit to not operate properly or IC breakdown before operation.

(3) Heat Radiation Design

In using an IC with large current flow such as power amp, regulator or driver, please design the device so that heat is appropriately radiated, not to exceed the specified junction temperature (T_j) at any time and condition. These ICs generate heat even during normal use. An inadequate IC heat radiation design can lead to decrease in IC life, deterioration of IC characteristics or IC breakdown. In addition, please design the device taking into consideration the effect of IC heat radiation with peripheral components.

(4) Back-EMF

When a motor rotates in the reverse direction, stops or slows down abruptly, a current flow back to the motor's power supply due to the effect of back-EMF. If the current sink capability of the power supply is small, the device's motor power supply and output pins might be exposed to conditions beyond absolute maximum ratings. To avoid this problem, take the effect of back-EMF into consideration in system design.

RESTRICTIONS ON PRODUCT USE

- Toshiba Corporation, and its subsidiaries and affiliates (collectively "TOSHIBA"), reserve the right to make changes to the information in this document, and related hardware, software and systems (collectively "Product") without notice.
- This document and any information herein may not be reproduced without prior written permission from TOSHIBA. Even with TOSHIBA's written permission, reproduction is permissible only if reproduction is without alteration/omission.
- Though TOSHIBA works continually to improve Product's quality and reliability, Product can malfunction or fail. Customers are responsible for complying with safety standards and for providing adequate designs and safeguards for their hardware, software and systems which minimize risk and avoid situations in which a malfunction or failure of Product could cause loss of human life, bodily injury or damage to property, including data loss or corruption. Before customers use the Product, create designs including the Product, or incorporate the Product into their own applications, customers must also refer to and comply with (a) the latest versions of all relevant TOSHIBA information, including without limitation, this document, the specifications, the data sheets and application notes for Product and the precautions and conditions set forth in the "TOSHIBA Semiconductor Reliability Handbook" and (b) the instructions for the application with which the Product will be used with or for. Customers are solely responsible for all aspects of their own product design or applications, including but not limited to (a) determining the appropriateness of the use of this Product in such design or applications; (b) evaluating and determining the applicability of any information contained in this document, or in charts, diagrams, programs, algorithms, sample application circuits, or any other referenced documents; and (c) validating all operating parameters for such designs and applications. **TOSHIBA ASSUMES NO LIABILITY FOR CUSTOMERS' PRODUCT DESIGN OR APPLICATIONS.**
- **PRODUCT IS NEITHER INTENDED NOR WARRANTED FOR USE IN EQUIPMENTS OR SYSTEMS THAT REQUIRE EXTRAORDINARILY HIGH LEVELS OF QUALITY AND/OR RELIABILITY, AND/OR A MALFUNCTION OR FAILURE OF WHICH MAY CAUSE LOSS OF HUMAN LIFE, BODILY INJURY, SERIOUS PROPERTY DAMAGE AND/OR SERIOUS PUBLIC IMPACT ("UNINTENDED USE").** Except for specific applications as expressly stated in this document, Unintended Use includes, without limitation, equipment used in nuclear facilities, equipment used in the aerospace industry, medical equipment, equipment used for automobiles, trains, ships and other transportation, traffic signaling equipment, equipment used to control combustions or explosions, safety devices, elevators and escalators, devices related to electric power, and equipment used in finance-related fields. **IF YOU USE PRODUCT FOR UNINTENDED USE, TOSHIBA ASSUMES NO LIABILITY FOR PRODUCT.** For details, please contact your TOSHIBA sales representative.
- Do not disassemble, analyze, reverse-engineer, alter, modify, translate or copy Product, whether in whole or in part.
- Product shall not be used for or incorporated into any products or systems whose manufacture, use, or sale is prohibited under any applicable laws or regulations.
- The information contained herein is presented only as guidance for Product use. No responsibility is assumed by TOSHIBA for any infringement of patents or any other intellectual property rights of third parties that may result from the use of Product. No license to any intellectual property right is granted by this document, whether express or implied, by estoppel or otherwise.
- **ABSENT A WRITTEN SIGNED AGREEMENT, EXCEPT AS PROVIDED IN THE RELEVANT TERMS AND CONDITIONS OF SALE FOR PRODUCT, AND TO THE MAXIMUM EXTENT ALLOWABLE BY LAW, TOSHIBA (1) ASSUMES NO LIABILITY WHATSOEVER, INCLUDING WITHOUT LIMITATION, INDIRECT, CONSEQUENTIAL, SPECIAL, OR INCIDENTAL DAMAGES OR LOSS, INCLUDING WITHOUT LIMITATION, LOSS OF PROFITS, LOSS OF OPPORTUNITIES, BUSINESS INTERRUPTION AND LOSS OF DATA, AND (2) DISCLAIMS ANY AND ALL EXPRESS OR IMPLIED WARRANTIES AND CONDITIONS RELATED TO SALE, USE OF PRODUCT, OR INFORMATION, INCLUDING WARRANTIES OR CONDITIONS OF MERCHANTABILITY, FITNESS FOR A PARTICULAR PURPOSE, ACCURACY OF INFORMATION, OR NONINFRINGEMENT.**
- Do not use or otherwise make available Product or related software or technology for any military purposes, including without limitation, for the design, development, use, stockpiling or manufacturing of nuclear, chemical, or biological weapons or missile technology products (mass destruction weapons). Product and related software and technology may be controlled under the applicable export laws and regulations including, without limitation, the Japanese Foreign Exchange and Foreign Trade Law and the U.S. Export Administration Regulations. Export and re-export of Product or related software or technology are strictly prohibited except in compliance with all applicable export laws and regulations.
- Please contact your TOSHIBA sales representative for details as to environmental matters such as the RoHS compatibility of Product. Please use Product in compliance with all applicable laws and regulations that regulate the inclusion or use of controlled substances, including without limitation, the EU RoHS Directive. **TOSHIBA ASSUMES NO LIABILITY FOR DAMAGES OR LOSSES OCCURRING AS A RESULT OF NONCOMPLIANCE WITH APPLICABLE LAWS AND REGULATIONS.**