

TOSHIBA CMOS Digital Integrated Circuit Silicon Monolithic

TC74VHC123AF, TC74VHC123AFN, TC74VHC123AFT, TC74VHC123AFK TC74VHC221AF, TC74VHC221AFN, TC74VHC221AFT, TC74VHC221AFK

Dual Monostable Multivibrator

TC74VHC123AF/AFN/AFT/AFK Retriggerble
TC74VHC221AF/AFN/AFT/AFK Non-Retriggerble

Note: xxxFN (JEDEC SOP) is not available in Japan.

The TC74VHC123A/221A are high speed CMOS MONOSTABLE MULTIVIBRATOR fabricated with silicon gate C²MOS technology.

There are two trigger inputs, \overline{A} input (negative edge), and B input (positive edge). These inputs are valid for a slow rise/fall time signal ($t_r = t_f = 1$ s) as they are schmitt trigger inputs. This device may also be triggered by using \overline{CLR} input (positive edge).

After triggering, the output stays in a MONOSTABLE state for a time period determined by the external resistor and capacitor (R_X , C_X). A low level at the \overline{CLR} input breaks this state.

Limits for C_X and R_X are:

External capacitor, C_X : No limit
External resistor, R_X : $V_{CC} = 2.0$ V more than 5 k Ω
 $V_{CC} \geq 3.0$ V more than 1 k Ω

An input protection circuit ensures that 0 to 5.5 V can be applied to the input pins without regard to the supply voltage. This device can be used to interface 5 V to 3 V systems and two supply systems such as battery back up. This circuit prevents device destruction due to mismatched supply and input voltages.

Features

- High speed: $t_{pd} = 8.1$ ns (typ.) at $V_{CC} = 5$ V
- Low power dissipation
Standby state: 4 μ A (max) at $T_a = 25^\circ\text{C}$
Active state: 600 μ A (max) at $T_a = 25^\circ\text{C}$
- High noise immunity: $V_{NIH} = V_{NIL} = 28\% V_{CC}$ (min)
- Power down protection is equipped with all inputs.
- Balanced propagation delays: $t_{pLH} \approx t_{pHL}$
- Wide operating voltage range: $V_{CC}(\text{opr}) = 2$ to 5.5 V
- Pin and function compatible with 74HC123A/221A

TC74VHC123AF, TC74VHC221AF

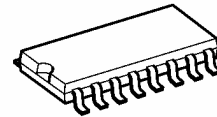

SOP16-P-300-1.27A

TC74VHC123AFN, TC74VHC221AFN

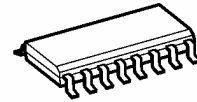

SOL16-P-150-1.27

TC74VHC123AFT, TC74VHC221AFT

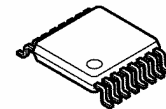

TSSOP16-P-0044-0.65A

TC74VHC123AFK, TC74VHC221AFK

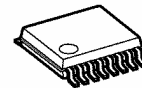

VSSOP16-P-0030-0.50

Weight

SOP16-P-300-1.27A	: 0.18 g (typ.)
SOL16-P-150-1.27	: 0.13 g (typ.)
TSSOP16-P-0044-0.65A	: 0.06 g (typ.)
VSSOP16-P-0030-0.50	: 0.02 g (typ.)

Pin Assignment

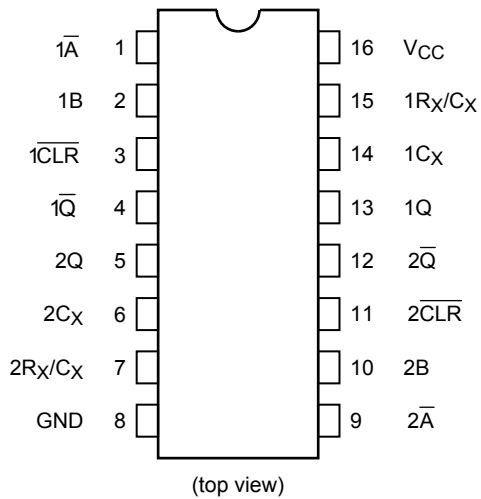

IEC Logic Symbol

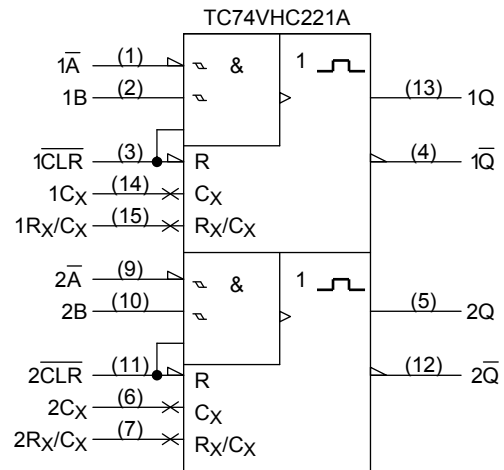
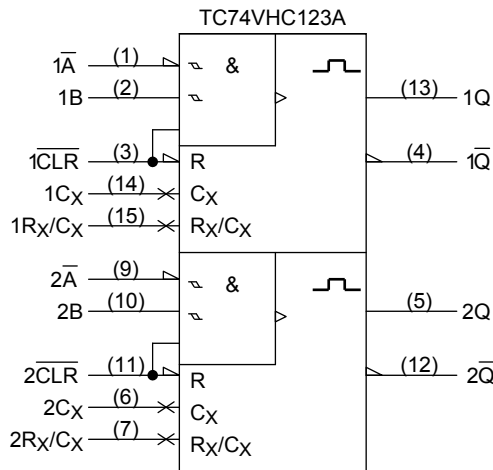

Truth Table

Inputs			Outputs		Function
\bar{A}	B	CLR	Q	\bar{Q}	
	H	H			Output Enable
X	L	H	L	H	Inhibit
H	X	H	L	H	Inhibit
L		H			Output Enable
L	H				Output Enable
X	X	L	L	H	Reset

X: Don't care

Block Diagram (Note 1) (Note 2)

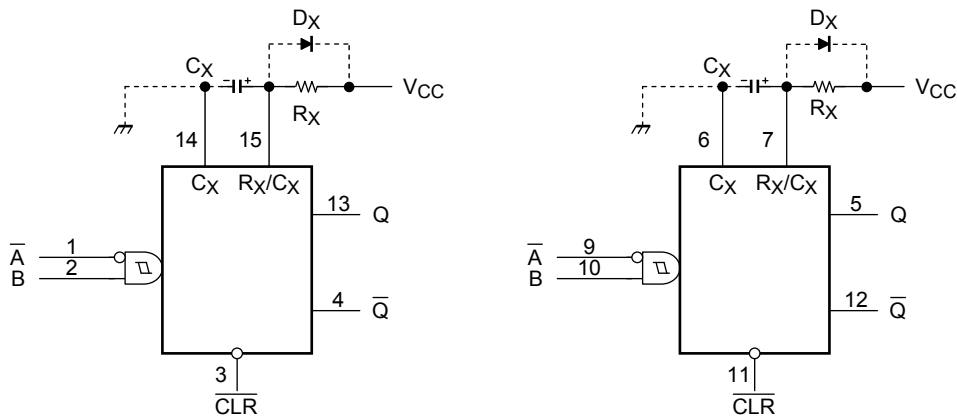

Note 1: C_X , R_X , D_X are external

Capacitor, resistor, and diode, respectively.

Note 2: External clamping diode, D_X ;

The external capacitor is charged to V_{CC} level in the wait state, i.e. when no trigger is applied.

If the supply voltage is turned off, C_X is discharged mainly through the internal (parasitic) diode. If C_X is sufficiently large and V_{CC} drops rapidly, there will be some possibility of damaging the IC through inrush current or latch-up. If the capacitance of the supply voltage filter is large enough and V_{CC} drops slowly, the inrush current is automatically limited and damage to the IC is avoided.

The maximum value of forward current through the parasitic diode is ± 20 mA.

In the case of a large C_X , the limit of fall time of the supply voltage is determined as follows:

$$t_f \geq (V_{CC} - 0.7) C_X / 20 \text{ mA}$$

(t_f is the time between the supply voltage turn off and the supply voltage reaching $0.4 V_{CC}$.)

In the even a system does not satisfy the above condition, an external clamping diode (D_X) is needed to protect the IC from inrush current.

System Diagram

TC74VHC123A

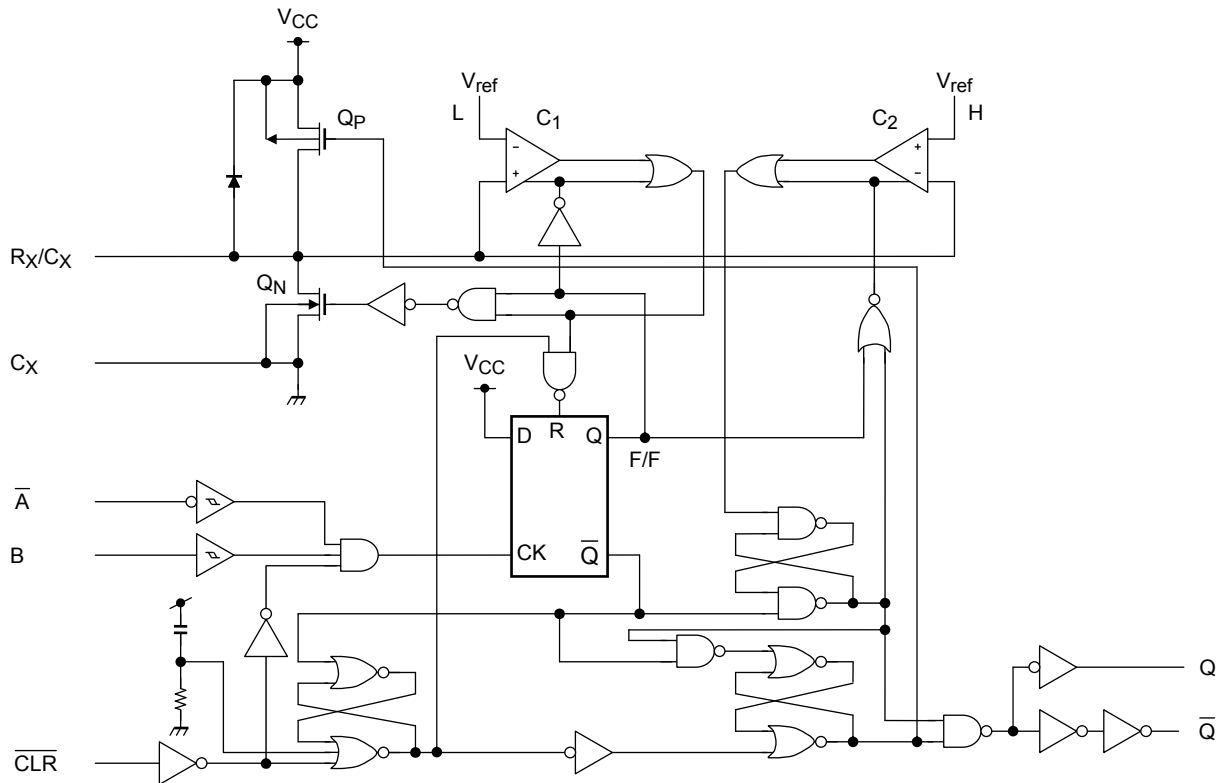

Timing Chart

TC74VHC123A

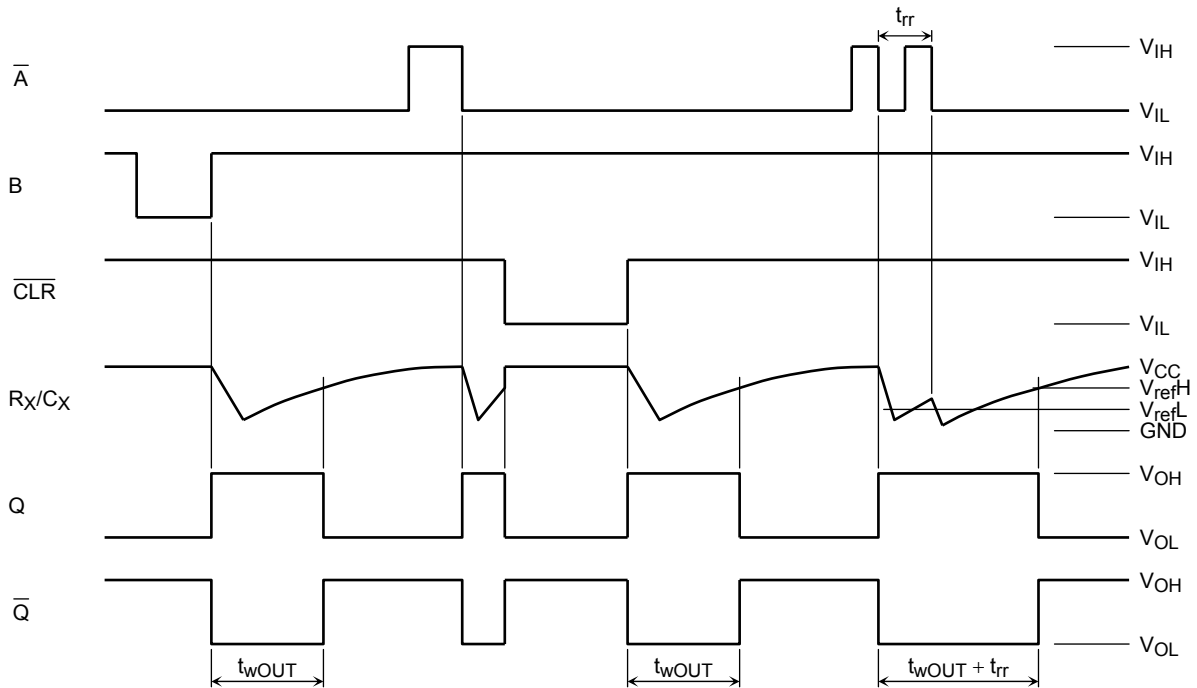

System Diagram

TC74VHC221A

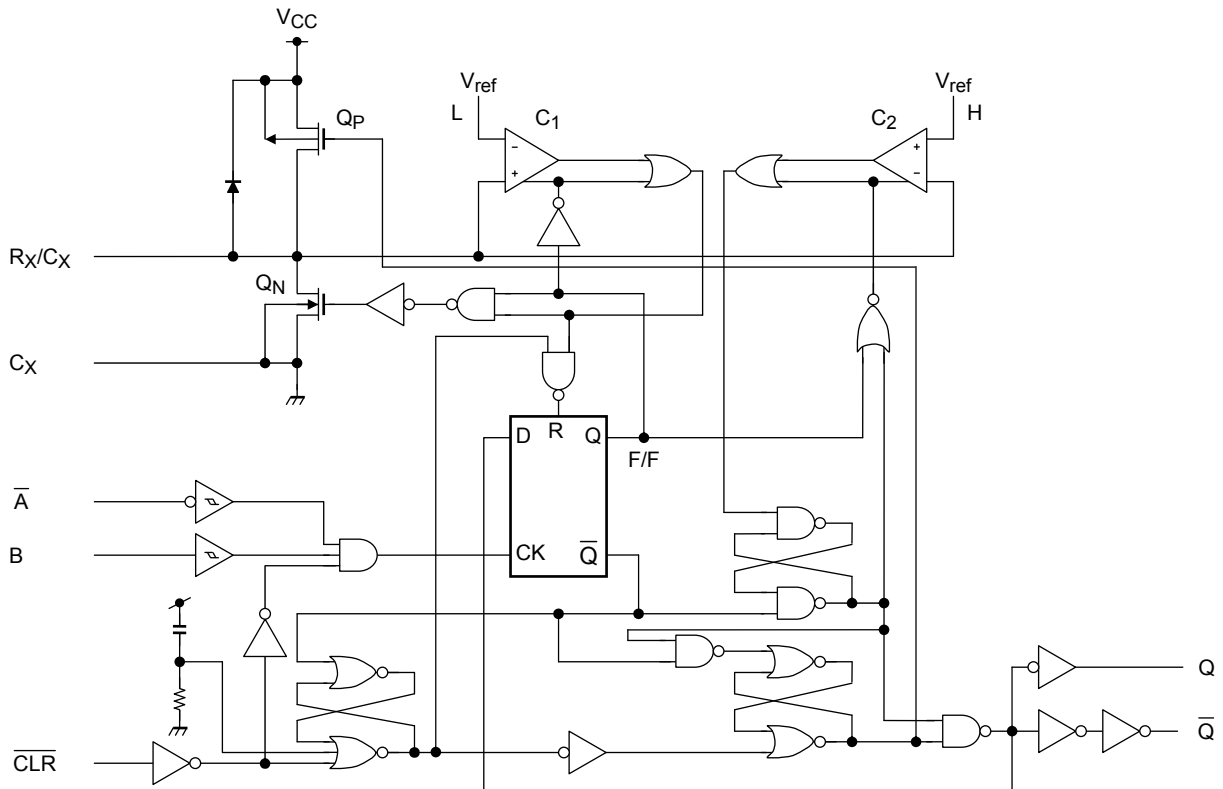

Timing Chart

TC74VHC221A

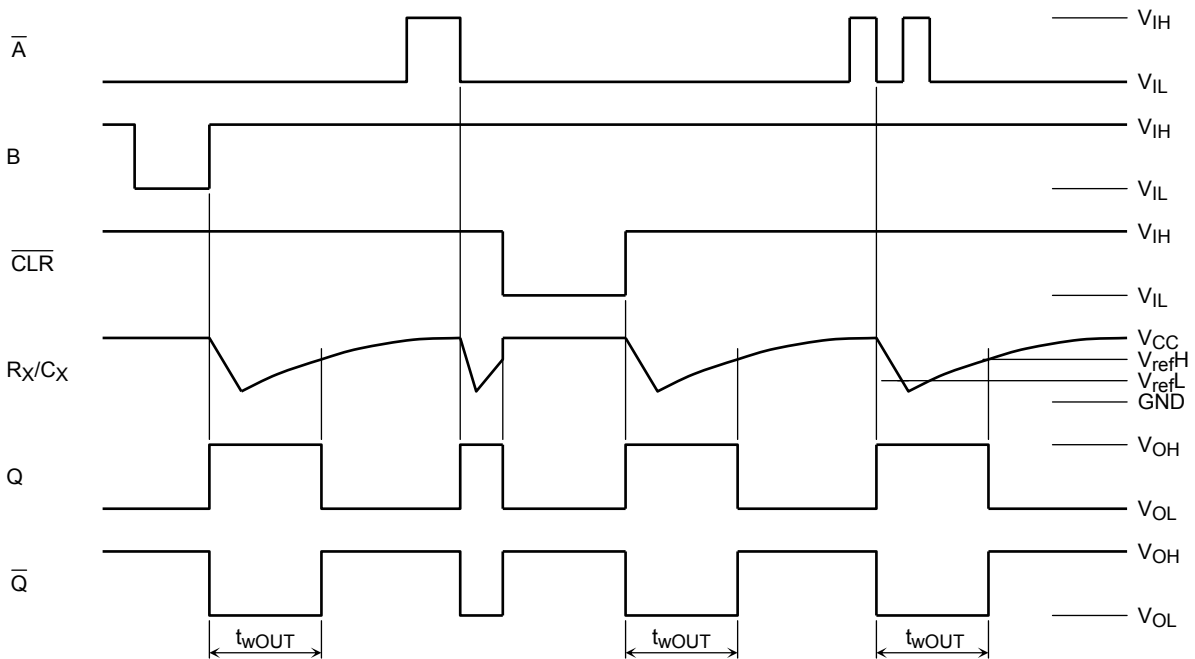

Functional Description

(1) Standby state

The external capacitor (C_X) is fully charged to V_{CC} in the stand-by state. That means, before triggering, the Q_P and Q_N transistors which are connected to the R_X/C_X node are in the off state. Two comparators that relate to the timing of the output pulse, and two reference voltage supplies turn off. The total supply current is only leakage current.

(2) Trigger operation

Trigger operation is effective in any of the following three cases. First, the condition where the \overline{A} input is low, and the B input has a rising signal; second, where the B input is high, and the \overline{A} input has a falling signal; and third, where the \overline{A} input is low and the B input is high, and the \overline{CLR} input has a rising signal.

After a trigger becomes effective, comparators C_1 and C_2 start operating, and Q_N is turned on. The external capacitor discharges through Q_N . The voltage level at the R_X/C_X node drops. If the R_X/C_X voltage level falls to the internal reference voltage V_{refL} , the output of C_1 becomes low. The flip-flop is then reset and Q_N turns off. At that moment C_1 stops but C_2 continues operating.

After Q_N turns off, the voltage at the R_X/C_X node starts rising at a rate determined by the time constant of external capacitor C_X and resistor R_X .

Upon triggering, output Q becomes high, following some delay time of the internal F/F and gates. It stays high even if the voltage of R_X/C_X changes from falling to rising. When R_X/C_X reaches the internal reference voltage V_{refH} , the output of C_2 becomes low, the output Q goes low and C_2 stops its operation. That means, after triggering, when the voltage level of the R_X/C_X node reaches V_{refH} , the IC returns to its MONOSTABLE state.

With large values of C_X and R_X , and ignoring the discharge time of the capacitor and internal delays of the IC, the width of the output pulse, t_w (OUT), is as follows:

$$t_w \text{ (OUT)} = 1.0 \cdot C_X \cdot R_X$$

(3) Retrigger operation (TC74VHC123A)

When a new trigger is applied to either input \overline{A} or B while in the MONOSTABLE state, it is effective only if the IC is charging C_X . The voltage level of the R_X/C_X node then falls to V_{refL} level again. Therefore the Q output stays high if the next trigger comes in before the time period set by C_X and R_X .

If the new trigger is very close to previous trigger, such as an occurrence during the discharge cycle, it will have no effect.

The minimum time for a trigger to be effective 2nd trigger, t_{rr} (min.), depends on V_{CC} and C_X .

(4) Reset operation

In normal operation, the \overline{CLR} input is held high. If \overline{CLR} is low, a trigger has no effect because the Q output is held low and the trigger control F/F is reset. Also, Q_P turns on and C_X is charged rapidly to V_{CC} .

This means if \overline{CLR} is set low, the IC goes into a wait state.

Absolute Maximum Ratings (Note)

Characteristics	Symbol	Rating	Unit
Supply voltage range	V_{CC}	-0.5 to 7.0	V
DC input voltage	V_{IN}	-0.5 to 7.0	V
DC output voltage	V_{OUT}	-0.5 to $V_{CC} + 0.5$	V
Input diode current	I_{IK}	-20	mA
Output diode current	I_{OK}	± 20	mA
DC output current	I_{OUT}	± 25	mA
DC V_{CC} /ground current	I_{CC}	± 50	mA
Power dissipation	P_D	180	mW
Storage temperature	T_{stg}	-65 to 150	$^{\circ}C$

Note: Exceeding any of the absolute maximum ratings, even briefly, lead to deterioration in IC performance or even destruction.

Using continuously under heavy loads (e.g. the application of high temperature/current/voltage and the significant change in temperature, etc.) may cause this product to decrease in the reliability significantly even if the operating conditions (i.e. operating temperature/current/voltage, etc.) are within the absolute maximum ratings and the operating ranges.

Please design the appropriate reliability upon reviewing the Toshiba Semiconductor Reliability Handbook ("Handling Precautions"/"Derating Concept and Methods") and individual reliability data (i.e. reliability test report and estimated failure rate, etc).

Operating Ranges (Note 1)

Characteristics	Symbol	Rating	Unit
Supply voltage	V_{CC}	2.0 to 5.5	V
Input voltage	V_{IN}	0 to 5.5	V
Output voltage	V_{OUT}	0 to V_{CC}	V
Operating temperature	T_{opr}	-40 to 85	$^{\circ}C$
Input rise and fall time	dt/dv	0 to 100 ($V_{CC} = 3.3 \pm 0.3$ V) 0 to 20 ($V_{CC} = 5 \pm 0.5$ V)	ns/V
External capacitor	C_X	No limitation (Note 2)	F
External resistor	R_X	≥ 5 k (Note 3) ($V_{CC} = 2.0$ V) ≥ 1 k (Note 3) ($V_{CC} \geq 3.0$ V)	Ω

Note 1: The operating ranges must be maintained to ensure the normal operation of the device. Unused inputs must be tied to either VCC or GND.

Note 2: The maximum allowable values of C_X and R_X are a function of leakage of capacitor C_X , the leakage of TC74VHC123A/221A, and leakage due to board layout and surface resistance.

Susceptibility to externally induced noise signals may occur for $R_X > 1$ M Ω .

Electrical Characteristics

DC Characteristics

Characteristics	Symbol	Test Condition		Ta = 25°C			Ta = -40 to 85°C		Unit	
				V _{CC} (V)	Min	Typ.	Max	Min		Max
High-level input voltage	V _{IH}	—		2.0 3.0 to 5.5	1.50 V _{CC} × 0.7	— —	— —	1.50 V _{CC} × 0.7	— —	V
Low-level input voltage	V _{IL}	—		2.0 3.0 to 5.5	— —	— —	— —	0.50 V _{CC} × 0.3	0.50 V _{CC} × 0.3	V
High-level output voltage	V _{OH}	V _{IN} = V _{IH} or V _{IL}	I _{OH} = -50 μA	2.0 3.0 4.5	1.9 2.9 4.4	2.0 3.0 4.5	— — —	1.9 2.9 4.4	— — —	V
			I _{OH} = -4 mA	3.0	2.58	—	—	2.48	—	
			I _{OH} = -8 mA	4.5	3.94	—	—	3.80	—	
Low-level output voltage	V _{OL}	V _{IN} = V _{IH} or V _{IL}	I _{OL} = 50 μA	2.0 3.0 4.5	— — —	0.0 0.0 0.0	0.1 0.1 0.1	— — —	0.1 0.1 0.1	V
			I _{OL} = 4 mA	3.0	—	—	0.36	—	0.44	
			I _{OL} = 8 mA	4.5	—	—	0.36	—	0.44	
Input leakage current	I _{IN}	V _{IN} = 5.5 V or GND		0 to 5.5	—	—	±0.1	—	±1.0	μA
R _X /C _X terminal off-state current	I _{IN}	V _{IN} = V _{CC} or GND		5.5	—	—	±0.25	—	±2.5	μA
Quiescent supply current	I _{CC}	V _{IN} = V _{CC} or GND		5.5	—	—	4.0	—	40.0	μA
Active-state supply current (Note)	I _{CC}	V _{IN} = V _{CC} or GND R _X /C _X = 0.5 V _{CC}		3.0	—	160	250	—	280	μA
				4.5	—	380	500	—	650	
				5.5	—	560	750	—	975	

Note: Per circuit

Timing Requirements (input: $t_r = t_f = 3 \text{ ns}$)

Characteristics	Symbol	Test Condition	Ta = 25°C		Ta = -40 to 85°C	Unit
			V _{CC} (V)	Typ.	Limit	
Minimum pulse width	$t_w(L)$	—	3.3 ± 0.3	—	5.0	ns
	$t_w(H)$		5.0 ± 0.5	—	5.0	
Minimum clear width ($\overline{\text{CLR}}$)	$t_w(L)$	—	3.3 ± 0.3	—	5.0	ns
Minimum retrigger time (Note)	t_{rr}	R _X = 1 kΩ	3.3 ± 0.3	60	—	ns
		C _X = 100 pF	5.0 ± 0.5	39	—	
		R _X = 1 kΩ	3.3 ± 0.3	1.5	—	μs
		C _X = 0.01 μF	5.0 ± 0.5	1.2	—	

Note: For TC74VHC123A only

AC Characteristics (input: $t_r = t_f = 3 \text{ ns}$)

Characteristics	Symbol	Test Condition	Ta = 25°C			Ta = -40 to 85°C		Unit		
			V _{CC} (V)	C _L (pF)	Min	Typ.	Max		Min	Max
Propagation delay time (\overline{A} , B-Q, \overline{Q})	t_{pLH}	—	3.3 ± 0.3	15	—	13.4	20.6	1.0	24.0	ns
				50	—	15.9	24.1	1.0	27.5	
	5.0 ± 0.5		15	—	8.1	12.0	1.0	14.0		
			50	—	9.6	14.0	1.0	16.0		
Propagation delay time ($\overline{\text{CLR}}$ trigger-Q, \overline{Q})	t_{pLH}	—	3.3 ± 0.3	15	—	14.5	22.4	1.0	26.0	ns
				50	—	17.0	25.9	1.0	29.5	
	5.0 ± 0.5		15	—	8.7	12.9	1.0	15.0		
			50	—	10.2	14.9	1.0	17.0		
Propagation delay time ($\overline{\text{CLR}}$ -Q, \overline{Q})	t_{pLH}	—	3.3 ± 0.3	15	—	10.3	15.8	1.0	18.5	ns
				50	—	12.8	19.3	1.0	22.0	
	5.0 ± 0.5		15	—	6.3	9.4	1.0	11.0		
			50	—	7.8	11.4	1.0	13.0		
Output pulse width	t_{wOUT}	C _X = 28 pF R _X = 2 kΩ	3.3 ± 0.3	50	—	160	240	—	300	ns
					—	133	200	—	240	
		C _X = 0.01 μF R _X = 10 kΩ	3.3 ± 0.3	50	90	100	110	90	110	μs
					90	100	110	90	110	
		C _X = 0.1 μF R _X = 10 kΩ	3.3 ± 0.3	50	0.9	1.0	1.1	0.9	1.1	ms
					0.9	1.0	1.1	0.9	1.1	
Output pulse width error between circuits (in same package)	Δt_{wOUT}	—	—	—	±1	—	—	—	%	
Input capacitance	C _{IN}	—	—	—	4	10	—	10	pF	
Power dissipation capacitance	C _{PD}	(Note)	—	—	73	—	—	—	pF	

Note: C_{PD} is defined as the value of the internal equivalent capacitance which is calculated from the operating current consumption without load.

Average operating current can be obtained by the equation:

$$I_{CC(opr)} = C_{PD} \cdot V_{CC} \cdot f_{IN} + I_{CC} \cdot \text{Duty}/100 + I_{CC}/2 \text{ (per circuit)}$$

(I_{CC}: active supply current)

(duty: %)

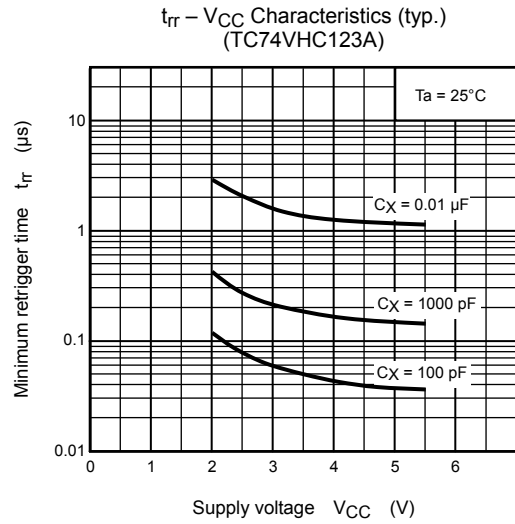
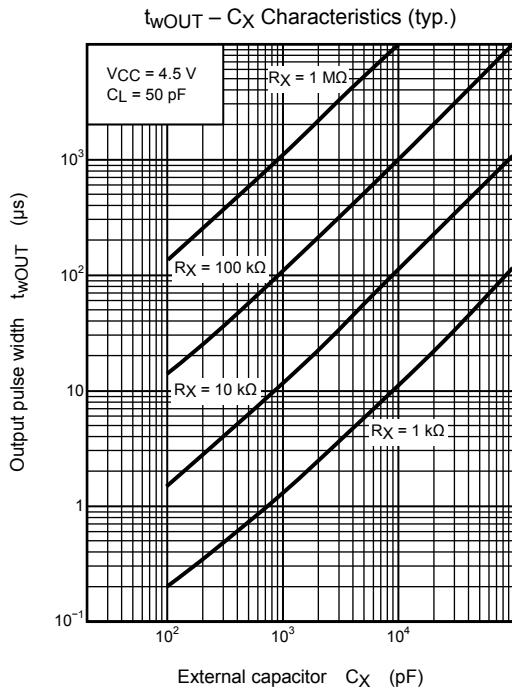

Output Pulse Width Constant K – Supply Voltage (typ.)
(external resistor (R_X) = 10 k Ω : $t_{wOUT} = K \cdot C_X \cdot R_X$)

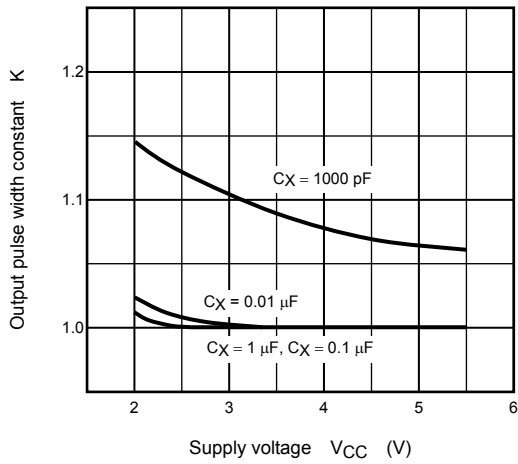

Input Equivalent Circuit

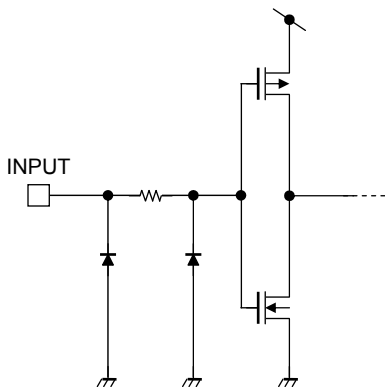

Package Dimensions

SOP16-P-300-1.27A

Unit: mm

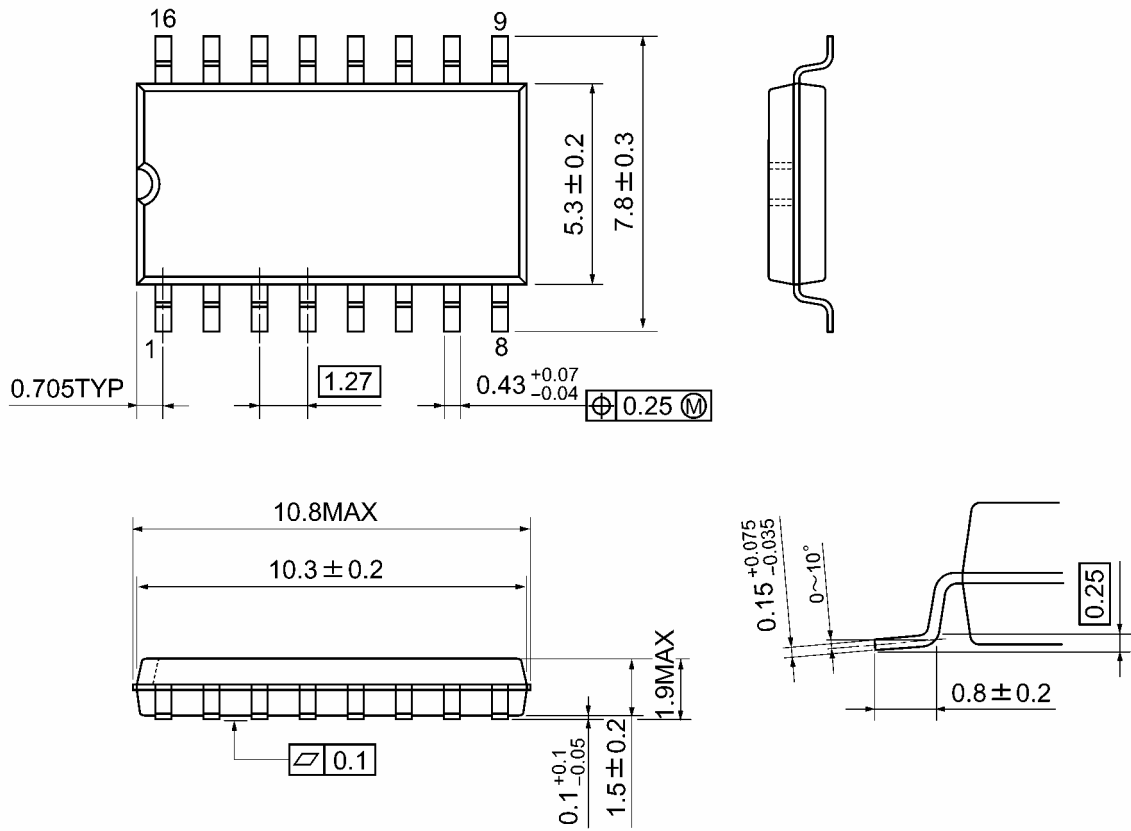

Weight: 0.18 g (typ.)

Package Dimensions (Note)

SOL16-P-150-1.27

Unit : mm

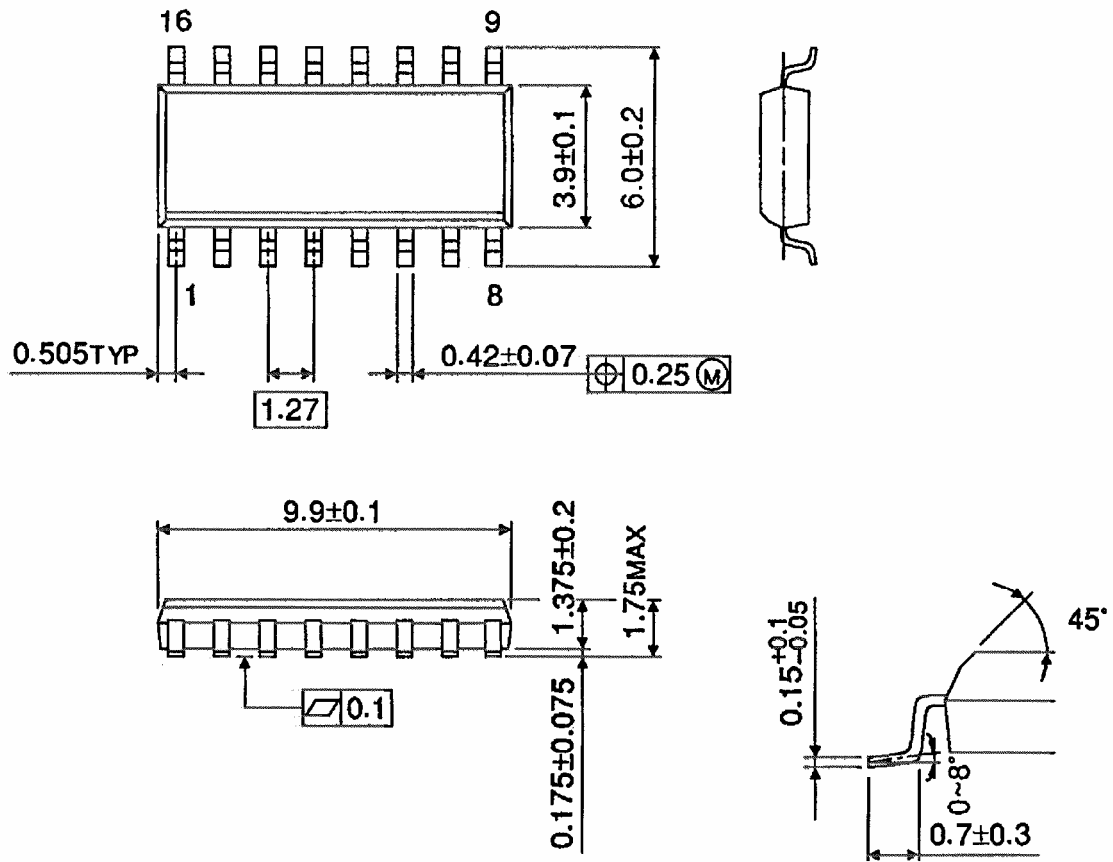

Note: This package is not available in Japan.

Weight: 0.13 g (typ.)

Package Dimensions

TSSOP16-P-0044-0.65A

Unit: mm

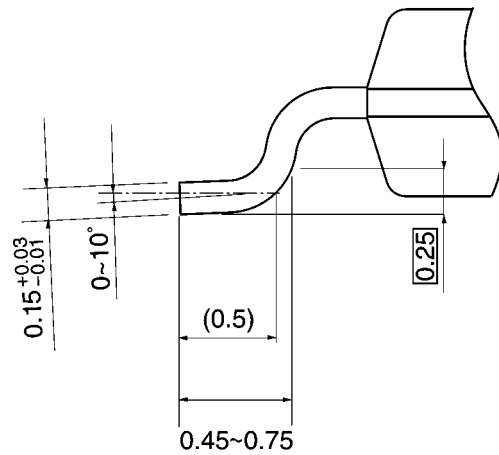
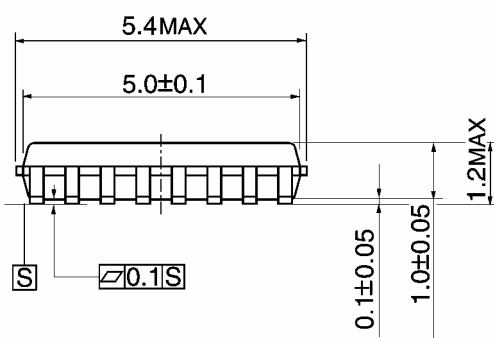
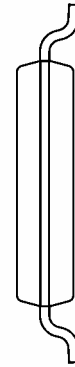
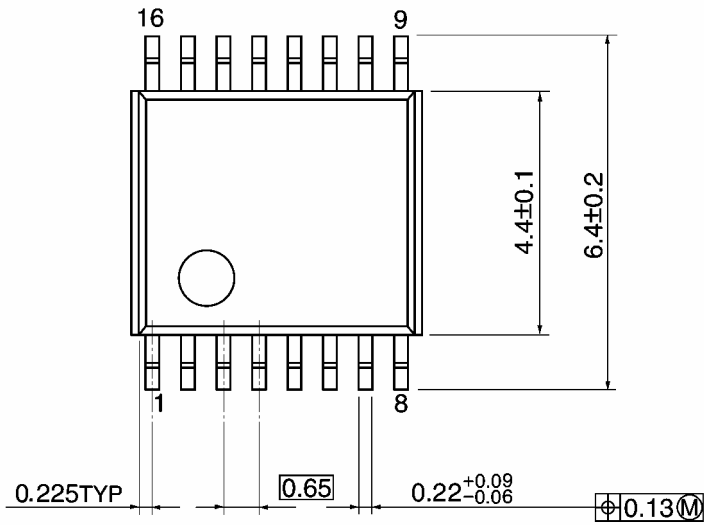

Weight: 0.06 g (typ.)

Package Dimensions

VSSOP16-P-0030-0.50

Unit: mm

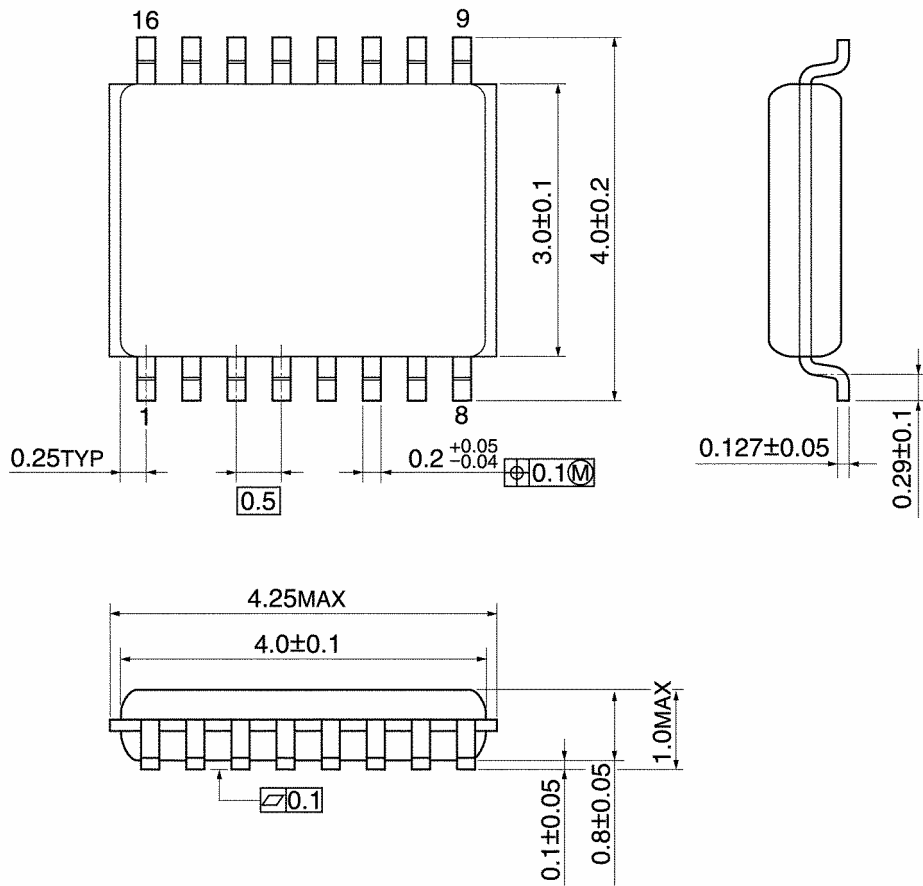

Weight: 0.02 g (typ.)

RESTRICTIONS ON PRODUCT USE

20070701-EN GENERAL

- The information contained herein is subject to change without notice.
- TOSHIBA is continually working to improve the quality and reliability of its products. Nevertheless, semiconductor devices in general can malfunction or fail due to their inherent electrical sensitivity and vulnerability to physical stress. It is the responsibility of the buyer, when utilizing TOSHIBA products, to comply with the standards of safety in making a safe design for the entire system, and to avoid situations in which a malfunction or failure of such TOSHIBA products could cause loss of human life, bodily injury or damage to property.
In developing your designs, please ensure that TOSHIBA products are used within specified operating ranges as set forth in the most recent TOSHIBA products specifications. Also, please keep in mind the precautions and conditions set forth in the "Handling Guide for Semiconductor Devices," or "TOSHIBA Semiconductor Reliability Handbook" etc.
- The TOSHIBA products listed in this document are intended for usage in general electronics applications (computer, personal equipment, office equipment, measuring equipment, industrial robotics, domestic appliances, etc.). These TOSHIBA products are neither intended nor warranted for usage in equipment that requires extraordinarily high quality and/or reliability or a malfunction or failure of which may cause loss of human life or bodily injury ("Unintended Usage"). Unintended Usage include atomic energy control instruments, airplane or spaceship instruments, transportation instruments, traffic signal instruments, combustion control instruments, medical instruments, all types of safety devices, etc.. Unintended Usage of TOSHIBA products listed in this document shall be made at the customer's own risk.
- The products described in this document shall not be used or embedded to any downstream products of which manufacture, use and/or sale are prohibited under any applicable laws and regulations.
- The information contained herein is presented only as a guide for the applications of our products. No responsibility is assumed by TOSHIBA for any infringements of patents or other rights of the third parties which may result from its use. No license is granted by implication or otherwise under any patents or other rights of TOSHIBA or the third parties.
- Please contact your sales representative for product-by-product details in this document regarding RoHS compatibility. Please use these products in this document in compliance with all applicable laws and regulations that regulate the inclusion or use of controlled substances. Toshiba assumes no liability for damage or losses occurring as a result of noncompliance with applicable laws and regulations.