

TOSHIBA CMOS Digital Integrated Circuit Silicon Monolithic

# TC74HC423AP, TC74HC423AF

## Dual Retriggerable Monostable Multivibrator

The TC74HC423A is a high speed CMOS MONOSTABLE MULTIVIBRATOR fabricated with silicon gate C<sup>2</sup>MOS technology.

It achieves the high speed operation similar to equivalent LSTTL while maintaining the CMOS low power dissipation.

There are two trigger inputs,  $\overline{A}$  input (negative edge), and B input (positive edge). These inputs are valid for a slow rise/fall time signal ( $t_r = t_f = 1$  s) as they are schmitt trigger inputs.

After triggering, the output stays in a MONOSTABLE state for a time period determined by the external resistor and capacitor ( $R_x, C_x$ ). A low level at the  $\overline{CLR}$  input breaks this state. In the MONOSTABLE state, if a new trigger is applied, it extends the MONOSTABLE period (retrigger mode).

Limitations for  $C_x$  and  $R_x$  are:

External capacitor,  $C_x$ : No limit

External resistor,  $R_x$ :  $V_{CC} = 2.0$  V more than 5 k $\Omega$

$V_{CC} \geq 3.0$  V more than 1 k $\Omega$

All inputs are equipped with protection circuits against static discharge or transient excess voltage.

### Features (Note)

- High speed:  $t_{pd} = 25$  ns (typ.) at  $V_{CC} = 5$  V
- Low power dissipation
  - Standby state:  $I_{CC} = 4$   $\mu$ A (max) at  $T_a = 25^\circ$ C
  - Active state:  $I_{CC} = 700$   $\mu$ A (max) at  $V_{CC} = 5$  V
- High noise immunity:  $V_{NIH} = V_{NIL} = 28\%$   $V_{CC}$  (min)
- Output drive capability: 10 LSTTL loads
- Symmetrical output impedance:  $|I_{OH}| = I_{OL} = 4$  mA (min)
- Balanced propagation delays:  $t_{pLH} \approx t_{pHL}$
- Wide operating voltage range:  $V_{CC} (opr) = 2\sim 6$  V
- Pin and function compatible with 74LS423

Note: In the case of using only one circuit,  $\overline{CLR}$  should be tied to GND,  $R_x/C_x \cdot C_x \cdot Q \cdot \overline{Q}$  should be tied to OPEN, the other inputs should be tied to  $V_{CC}$  or GND.

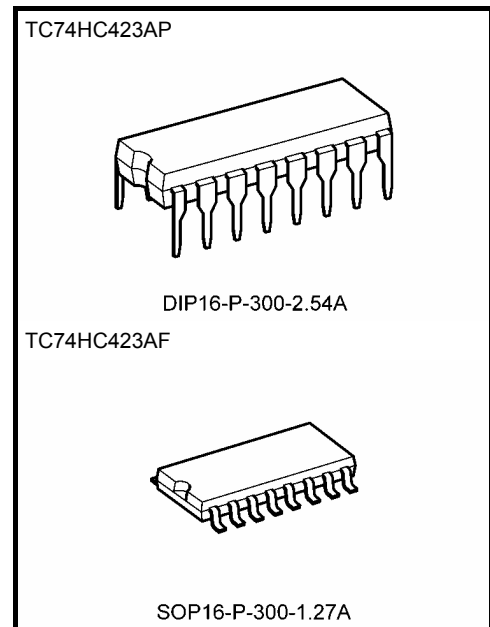

Weight	
DIP16-P-300-2.54A	: 1.00 g (typ.)
SOP16-P-300-1.27A	: 0.18 g (typ.)

## Pin Assignment

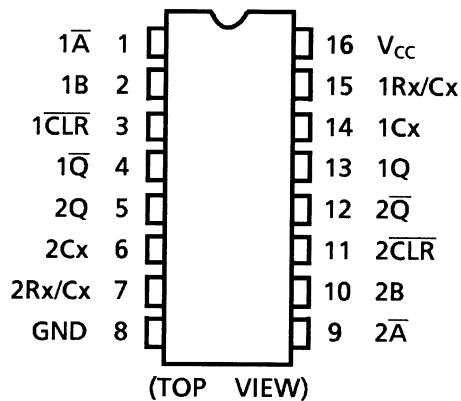

## IEC Logic Symbol

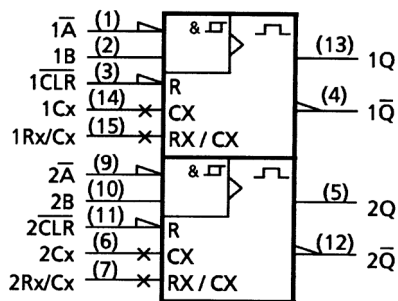

## Block Diagram (Note 1)(Note 2)

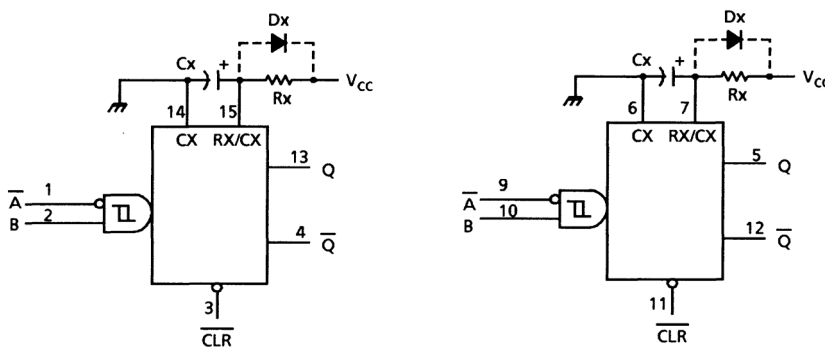

Note 1: Cx, Rx, Dx are external capacitor, resistor, and diode, respectively.

Note 2: External clamping diode, Dx;

The external capacitor is charged to  $V_{CC}$  level in the wait state, i.e. when no trigger is applied.

If the supply voltage is turned off, Cx is discharged mainly through the internal (parasitic) diode. If Cx is sufficiently large and  $V_{CC}$  drops rapidly, there will be some possibility of damaging the IC through inrush current or latch-up. If the capacitance of the supply voltage filter is large enough and  $V_{CC}$  drops slowly, the inrush current is automatically limited and damage to the IC is avoided.

The maximum value of forward current through the parasitic diode is  $\pm 20$  mA.







In the case of a large Cx, the limit of fall time of the supply voltage is determined as follows:

$$t_f \geq (V_{CC} - 0.7) Cx / 20 \text{ mA}$$

( $t_f$  is the time between the supply voltage turn off and the supply voltage reaching  $0.4 V_{CC}$ .)

In the event a system does not satisfy the above condition, an external clamping diode (Dx) is needed to protect the IC from inrush current.

**Truth Table**

Inputs			Outputs		Note
$\bar{A}$	B	$\overline{CLR}$	Q	$\bar{Q}$	
	H	H			Output Enable
X	L	H	L	H	Inhibit
H	X	H	L	H	Inhibit
L		H			Output Enable
X	X	L	L	H	Reset

X: Don't care

**System Diagram**

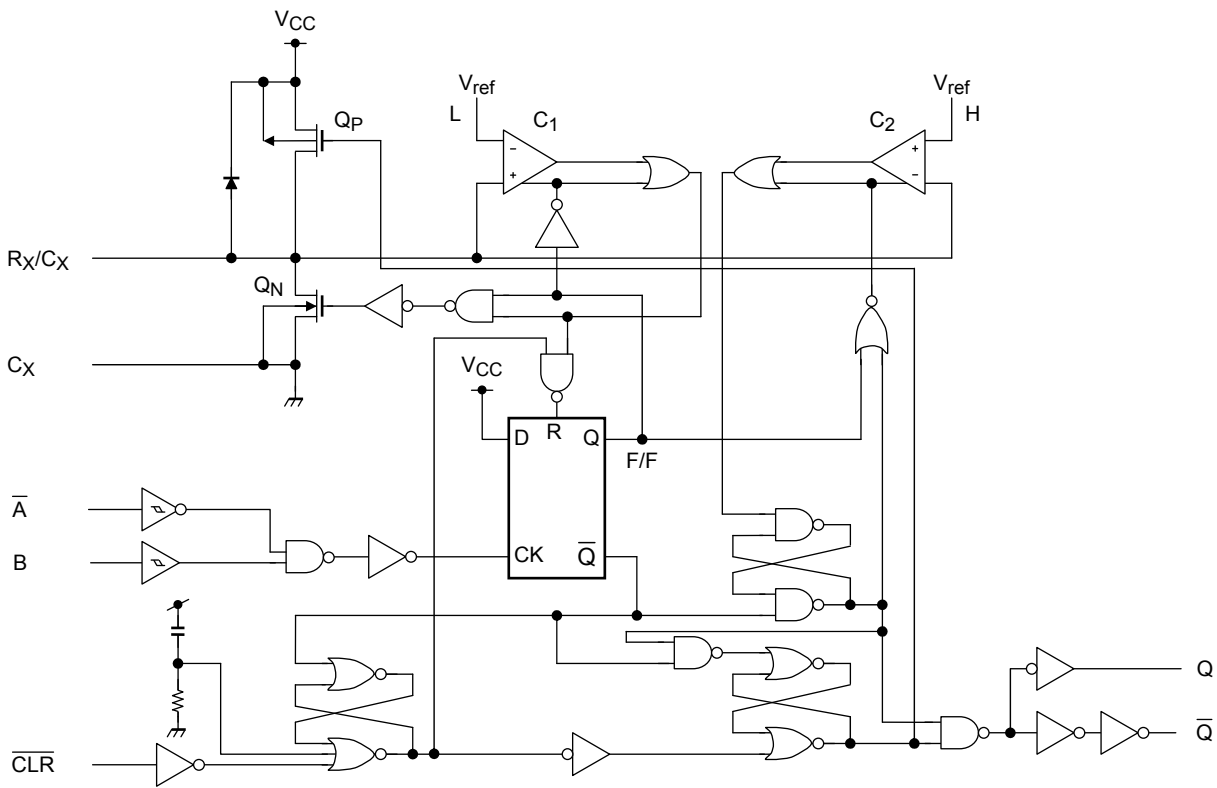

**Timing Chart**

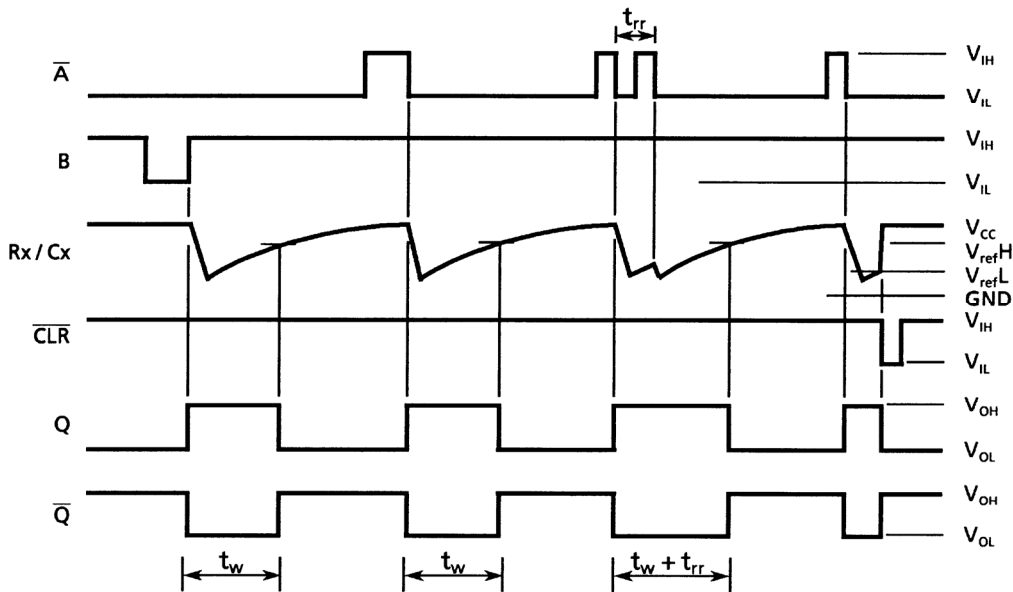

**Functional Description**

(1) Stand-by state

The external capacitor C<sub>x</sub> is fully charged to V<sub>CC</sub> in the stand-by state. That means, before triggering, the Q<sub>P</sub> and Q<sub>N</sub> transistors which are connected to the Rx/C<sub>x</sub> node are in the off state. Two comparators that relate to the timing of the output pulse, and two reference voltage supplies turn off. The total supply current is only leakage current.

(2) Trigger operation

Trigger operation is effective in either of the following two cases. First, the condition where the  $\bar{A}$  input is low, and the B input has a rising signal; second, where the B input is high, and the  $\bar{A}$  input has a falling signal.

After a trigger becomes effective, comparators C1 and C2 start operating, and Q<sub>N</sub> is turned on. The external capacitor discharges through Q<sub>N</sub>. The voltage level of the Rx/C<sub>x</sub> node drops. If the Rx/C<sub>x</sub> voltage level falls to the internal reference voltage V<sub>ref L</sub>, the output of C1 becomes low. The flip-flop is then reset and Q<sub>N</sub> turns off. At that moment C1 stops but C2 continues operating.

After Q<sub>N</sub> turns off, the voltage at the Rx/C<sub>x</sub> starts rising at a rate determined by the time constant of external capacitor C<sub>x</sub> and resistor R<sub>x</sub>.

Upon the triggering, output Q becomes high, following some delay time of the internal F/F and gates. It stays high even if the voltage of Rx/C<sub>x</sub> changes from falling to rising. When Rx/C<sub>x</sub> reaches the internal reference voltage V<sub>ref H</sub>, the output of C2 becomes low, the output Q goes low and C2 stops its operation. That means, after triggering, when the voltage level of the Rx/C<sub>x</sub> reaches V<sub>ref H</sub>, the IC returns to its MONOSTABLE state.

With large values of C<sub>x</sub> and R<sub>x</sub>, and ignoring the discharge time of the capacitor and internal delays of the IC, the width of the output pulse,  $t_w$  (OUT), is as follows:

$$t_w (\text{OUT}) = 1.0 \cdot C_x \cdot R_x$$

(3) Retrigger operation

When a new trigger is applied to input  $\bar{A}$  or B while in the MONOSTABLE state, it is effective only if the IC is charging C<sub>x</sub>. The voltage level of the Rx/C<sub>x</sub> node then falls to V<sub>ref L</sub> level again. Therefore the Q output stays high if the next trigger comes in before the time period set by C<sub>x</sub> and R<sub>x</sub>.

If the 2nd trigger is very close to previous trigger, such as an occurrence during the discharge cycle, it will have no effect.

The minimum time for a trigger to be effective 2nd trigger,  $t_{rr}$  (min), depends on V<sub>CC</sub> and C<sub>x</sub>.

(4) Reset operation

In normal operation,  $\overline{\text{CLR}}$  input is held high. If  $\overline{\text{CLR}}$  is low, a trigger has no effect because the Q output is held low and the trigger control F/F is reset. Also, Q<sub>P</sub> turns on and C<sub>x</sub> is charged rapidly to V<sub>CC</sub>.

This means if  $\overline{\text{CLR}}$  input is set low, the IC goes into a wait state.

## Absolute Maximum Ratings (Note 1)

Characteristics	Symbol	Rating	Unit
Supply voltage range	$V_{CC}$	-0.5~7	V
DC input voltage	$V_{IN}$	-0.5~ $V_{CC} + 0.5$	V
DC output voltage	$V_{OUT}$	-0.5~ $V_{CC} + 0.5$	V
Input diode current	$I_{IK}$	±20	mA
Output diode current	$I_{OK}$	±20	mA
DC output current	$I_{OUT}$	±25	mA
DC $V_{CC}$ /ground current	$I_{CC}$	±50	mA
Power dissipation	$P_D$	500 (DIP) (Note 2)/180 (SOP)	mW
Storage temperature	$T_{stg}$	-65~150	°C

Note 1: Exceeding any of the absolute maximum ratings, even briefly, lead to deterioration in IC performance or even destruction.

Using continuously under heavy loads (e.g. the application of high temperature/current/voltage and the significant change in temperature, etc.) may cause this product to decrease in the reliability significantly even if the operating conditions (i.e. operating temperature/current/voltage, etc.) are within the absolute maximum ratings and the operating ranges.

Please design the appropriate reliability upon reviewing the Toshiba Semiconductor Reliability Handbook ("Handling Precautions"/"Derating Concept and Methods") and individual reliability data (i.e. reliability test report and estimated failure rate, etc).

Note 2: 500 mW in the range of  $T_a = -40\sim 65^\circ\text{C}$ . From  $T_a = 65$  to  $85^\circ\text{C}$  a derating factor of  $-10\text{ mW}/^\circ\text{C}$  shall be applied until 300 mW.

## Operating Ranges (Note 1)

Characteristics	Symbol	Rating	Unit
Supply voltage	$V_{CC}$	2~6	V
Input voltage	$V_{IN}$	0~ $V_{CC}$	V
Output voltage	$V_{OUT}$	0~ $V_{CC}$	V
Operating temperature	$T_{opr}$	-40~85	°C
Input rise and fall time ( $\overline{\text{CLR}}$ only)	$t_r, t_f$	0~1000 ( $V_{CC} = 2.0\text{ V}$ ) 0~500 ( $V_{CC} = 4.5\text{ V}$ ) 0~400 ( $V_{CC} = 6.0\text{ V}$ )	ns
External capacitor	$C_x$	No limitation (Note 2)	F
External resistor	$R_x$	≥5 k ( $V_{CC} = 2.0\text{ V}$ ) (Note 2) ≥1 k ( $V_{CC} \geq 3.0\text{ V}$ ) (Note 2)	Ω

Note 1: The operating ranges must be maintained to ensure the normal operation of the device. Unused inputs must be tied to either VCC or GND.

Note 2: The maximum allowable values of  $C_x$  and  $R_x$  are a function of leakage of capacitor  $C_x$ , the leakage of TC74HC423A, and leakage due to board layout and surface resistance.

Susceptibility to externally induced noise signals may occur for  $R_x > 1\text{ M}\Omega$ .

## Electrical Characteristics

### DC Characteristics

Characteristics	Symbol	Test Condition		Ta = 25°C			Ta = -40~85°C		Unit	
				V <sub>CC</sub> (V)	Min	Typ.	Max	Min		Max
High-level input voltage	V <sub>IH</sub>	—		2.0	1.50	—	—	1.50	—	V
				4.5	3.15	—	—	3.15	—	
				6.0	4.20	—	—	4.20	—	
Low-level input voltage	V <sub>IL</sub>	—		2.0	—	—	0.50	—	0.50	V
				4.5	—	—	1.35	—	1.35	
				6.0	—	—	1.80	—	1.80	
High-level output voltage (Q, $\bar{Q}$ )	V <sub>OH</sub>	V <sub>IN</sub> = V <sub>IH</sub> or V <sub>IL</sub>	I <sub>OH</sub> = -20 μA	2.0	1.9	2.0	—	1.9	—	V
				4.5	4.4	4.5	—	4.4	—	
				6.0	5.9	6.0	—	5.9	—	
			I <sub>OH</sub> = -4 mA	4.5	4.18	4.31	—	4.13	—	
				6.0	5.68	5.80	—	5.63	—	
				I <sub>OH</sub> = -5.2 mA	4.5	—	—	—	—	
Low-level output voltage (Q, $\bar{Q}$ )	V <sub>OL</sub>	V <sub>IN</sub> = V <sub>IH</sub> or V <sub>IL</sub>	I <sub>OL</sub> = 20 μA	2.0	—	0.0	0.1	—	0.1	V
				4.5	—	0.0	0.1	—	0.1	
				6.0	—	0.0	0.1	—	0.1	
			I <sub>OL</sub> = 4 mA	4.5	—	0.17	0.26	—	0.33	
				6.0	—	0.18	0.26	—	0.33	
				I <sub>OL</sub> = 5.2 mA	4.5	—	—	—	—	
Input leakage current	I <sub>IN</sub>	V <sub>IN</sub> = V <sub>CC</sub> or GND		6.0	—	—	±0.1	—	±1.0	μA
				4.5	—	—	±0.1	—	±1.0	
				2.0	—	—	±0.1	—	±1.0	
Rx/Cx terminal off-state current	I <sub>IN</sub>	V <sub>IN</sub> = V <sub>CC</sub> or GND		6.0	—	—	±0.1	—	±1.0	μA
				4.5	—	—	±0.1	—	±1.0	
				2.0	—	—	±0.1	—	±1.0	
Quiescent supply current	I <sub>CC</sub>	V <sub>IN</sub> = V <sub>CC</sub> or GND		6.0	—	—	4.0	—	40.0	μA
				4.5	—	—	4.0	—	40.0	
				2.0	—	—	4.0	—	40.0	
Active-state supply current (Note)	I <sub>CC</sub>	V <sub>IN</sub> = V <sub>CC</sub> or GND Rx/Cx = 0.5 V <sub>CC</sub>		2.0	—	45	200	—	260	μA
				4.5	—	400	500	—	650	
				6.0	—	0.7	1.0	—	1.3	

Note: Per circuit

### Timing Requirements (input: $t_r = t_f = 6 \text{ ns}$ )

Characteristics	Symbol	Test Condition	Ta = 25°C		Ta = -40 ~85°C		Unit
			V <sub>CC</sub> (V)	Typ.	Limit	Limit	
Minimum pulse width	$t_W$ (L) $t_W$ (H)	—	2.0	—	75	95	ns
			4.5	—	15	19	
			6.0	—	13	16	
Minimum clear pulse width	$t_W$ (L)	—	2.0	—	75	95	ns
			4.5	—	15	19	
			6.0	—	13	16	
Minimum clear removal time	$t_{rem}$	—	2.0	—	5	5	ns
			4.5	—	5	5	
			6.0	—	5	5	
Minimum retrigger time	$t_{rr}$	Rx = 1 kΩ Cx = 100 pF	2.0	325	—	—	ns
			4.5	108	—	—	
			6.0	78	—	—	
		Rx = 1 kΩ Cx = 0.01 μF	2.0	5.0	—	—	μs
			4.5	1.4	—	—	
			6.0	1.2	—	—	

### AC Characteristics (C<sub>L</sub> = 15 pF, V<sub>CC</sub> = 5 V, Ta = 25°C, input: $t_r = t_f = 6 \text{ ns}$ )

Characteristics	Symbol	Test Condition	Min	Typ.	Max	Unit
Output transition time	$t_{TLH}$	—	—	4	8	ns
	$t_{THL}$					
Propagation delay time ( $\bar{A}$ , B-Q, $\bar{Q}$ )	$t_{pLH}$	—	—	25	36	ns
	$t_{pHL}$					
Propagation delay time ( $\bar{CL}$ -Q, $\bar{Q}$ )	$t_{pLH}$	—	—	16	27	ns
	$t_{pHL}$					

## AC Characteristics ( $C_L = 50 \text{ pF}$ , input: $t_r = t_f = 6 \text{ ns}$ )

Characteristics	Symbol	Test Condition	$V_{CC}$ (V)	$T_a = 25^\circ\text{C}$			$T_a = -40\sim 85^\circ\text{C}$		Unit
				Min	Typ.	Max	Min	Max	
Output transition time	$t_{TLH}$ $t_{THL}$	—	2.0	—	30	75	—	95	ns
			4.5	—	8	15	—	19	
			6.0	—	7	13	—	16	
Propagation delay time ( $\bar{A}$ , B-Q, $\bar{Q}$ )	$t_{pLH}$ $t_{pHL}$	—	2.0	—	102	210	—	265	ns
			4.5	—	29	42	—	53	
			6.0	—	22	36	—	45	
Propagation delay time ( $\bar{CL}$ -Q, $\bar{Q}$ )	$t_{pLH}$ $t_{pHL}$	—	2.0	—	68	160	—	200	ns
			4.5	—	20	32	—	40	
			6.0	—	16	27	—	34	
Output pulse width	$t_{wOUT}$	$C_x = 28 \text{ pF}$ $R_x = 6 \text{ k}\Omega$ ( $V_{CC} = 2 \text{ V}$ ) $R_x = 2 \text{ k}\Omega$ ( $V_{CC} = 4.5 \text{ V}, 6 \text{ V}$ )	2.0	—	700	2000	—	2500	ns
			4.5	—	250	400	—	500	
			6.0	—	210	340	—	425	
		$C_x = 0.01 \text{ }\mu\text{F}$ $R_x = 10 \text{ k}\Omega$	2.0	90	110	130	90	130	$\mu\text{s}$
			4.5	95	105	115	95	115	
			6.0	95	105	115	95	115	
		$C_x = 0.1 \text{ }\mu\text{F}$ $R_x = 10 \text{ k}\Omega$	2.0	0.9	1.0	1.2	0.9	1.2	ms
			4.5	0.9	1.0	1.1	0.9	1.1	
			6.0	0.9	1.0	1.1	0.9	1.1	
Output pulse width error between circuits (in same package)	$\Delta t_{wOUT}$	—	—	—	$\pm 1$	—	—	—	%
Input capacitance	$C_{IN}$	—	—	—	5	10	—	10	pF
Power dissipation capacitance	$C_{PD}$ (Note)	—	—	—	162	—	—	—	pF

Note:  $C_{PD}$  is defined as the value of the internal equivalent capacitance which is calculated from the operating current consumption without load.

Average operating current can be obtained by the equation:

$$I_{CC}(\text{opr}) = C_{PD} \cdot V_{CC} \cdot f_{IN} + I_{CC}' \cdot \text{duty}/100 + I_{CC}/2 \text{ (per circuit)}$$

( $I_{CC}'$ : active supply current)

(duty: %)



Output Pulse Width Constant K – Supply Voltage (typical)  
 (EXTERNAL RESISTOR (Rx) = 10kΩ :  $t_{WOUT} = K \cdot Cx \cdot Rx$ )

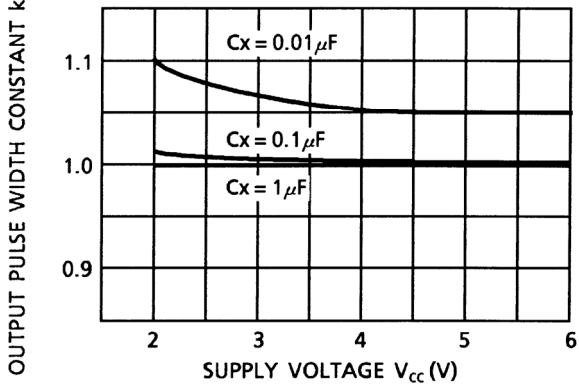

$t_{WOUT} - Cx$  Characteristics (typ.)

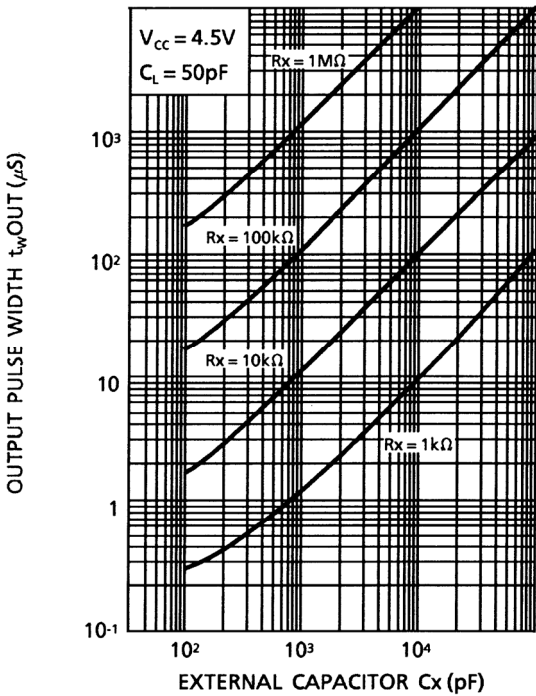

$t_{rr} - V_{CC}$  Characteristics (typ.)

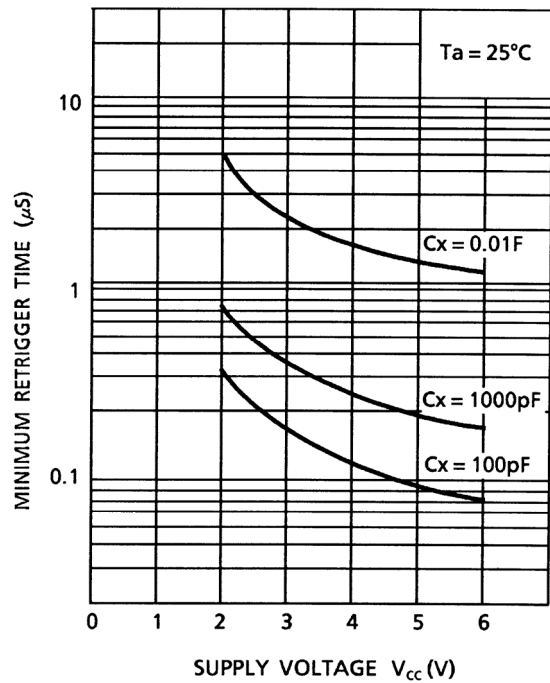

## Package Dimensions

DIP16-P-300-2.54A

Unit : mm

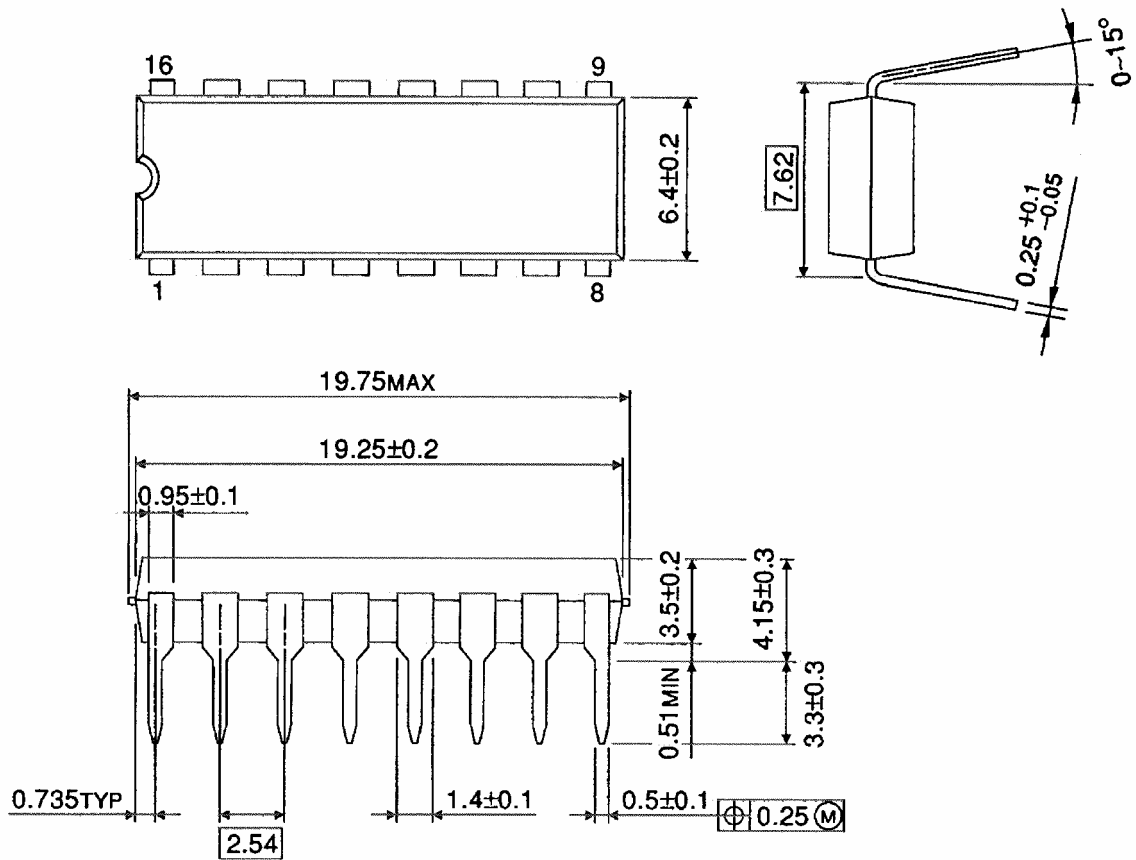

Weight: 1.00 g (typ.)

**Package Dimensions**

SOP16-P-300-1.27A

Unit: mm

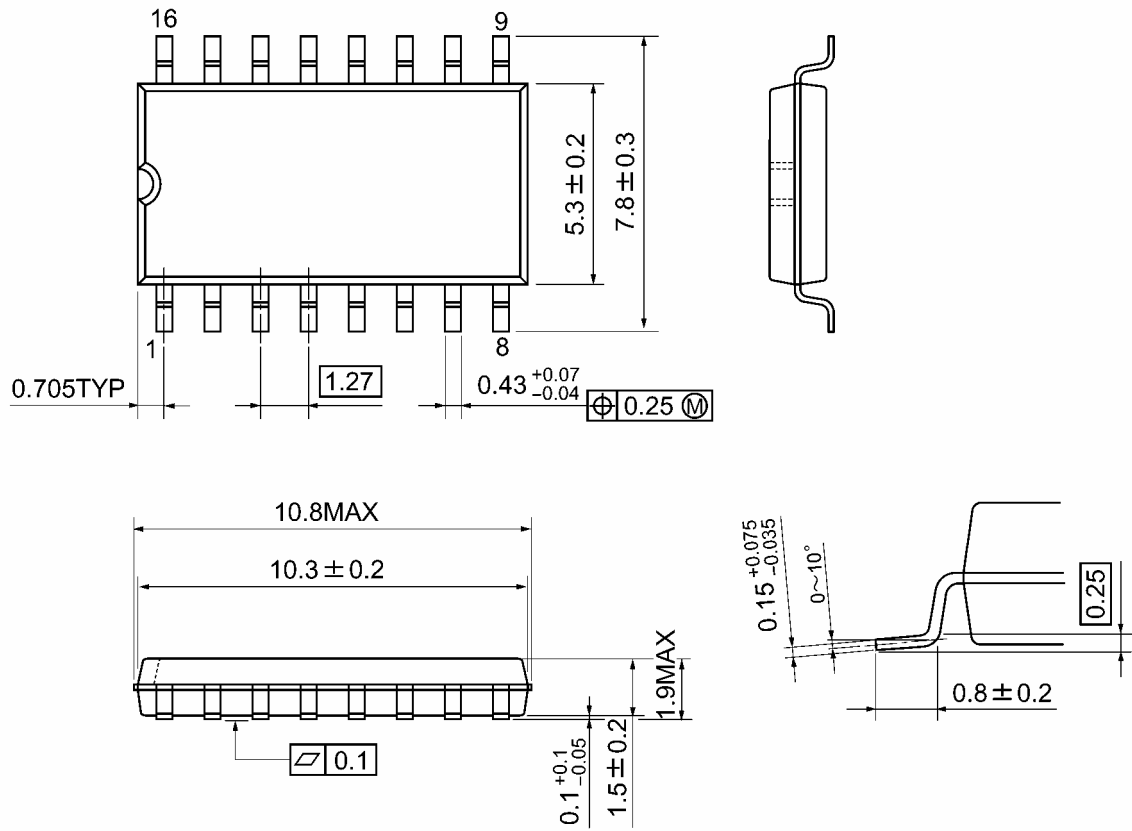

Weight: 0.18 g (typ.)

**RESTRICTIONS ON PRODUCT USE**

20070701-EN GENERAL

- The information contained herein is subject to change without notice.
- TOSHIBA is continually working to improve the quality and reliability of its products. Nevertheless, semiconductor devices in general can malfunction or fail due to their inherent electrical sensitivity and vulnerability to physical stress. It is the responsibility of the buyer, when utilizing TOSHIBA products, to comply with the standards of safety in making a safe design for the entire system, and to avoid situations in which a malfunction or failure of such TOSHIBA products could cause loss of human life, bodily injury or damage to property.  
In developing your designs, please ensure that TOSHIBA products are used within specified operating ranges as set forth in the most recent TOSHIBA products specifications. Also, please keep in mind the precautions and conditions set forth in the "Handling Guide for Semiconductor Devices," or "TOSHIBA Semiconductor Reliability Handbook" etc.
- The TOSHIBA products listed in this document are intended for usage in general electronics applications (computer, personal equipment, office equipment, measuring equipment, industrial robotics, domestic appliances, etc.). These TOSHIBA products are neither intended nor warranted for usage in equipment that requires extraordinarily high quality and/or reliability or a malfunction or failure of which may cause loss of human life or bodily injury ("Unintended Usage"). Unintended Usage include atomic energy control instruments, airplane or spaceship instruments, transportation instruments, traffic signal instruments, combustion control instruments, medical instruments, all types of safety devices, etc.. Unintended Usage of TOSHIBA products listed in this document shall be made at the customer's own risk.
- The products described in this document shall not be used or embedded to any downstream products of which manufacture, use and/or sale are prohibited under any applicable laws and regulations.
- The information contained herein is presented only as a guide for the applications of our products. No responsibility is assumed by TOSHIBA for any infringements of patents or other rights of the third parties which may result from its use. No license is granted by implication or otherwise under any patents or other rights of TOSHIBA or the third parties.
- Please contact your sales representative for product-by-product details in this document regarding RoHS compatibility. Please use these products in this document in compliance with all applicable laws and regulations that regulate the inclusion or use of controlled substances. Toshiba assumes no liability for damage or losses occurring as a result of noncompliance with applicable laws and regulations.