

TENTATIVE TOSHIBA MOS DIGITAL INTEGRATED CIRCUIT SILICON GATE CMOS

131,072-WORD BY 8-BIT STATIC RAM

DESCRIPTION

The TC551001CPI/CFI/CFTI/CTRI/CSTI/CSRI is a 1,048,576-bit static random access memory (SRAM) organized as 131,072 words by 8 bits. Fabricated using Toshiba's CMOS Silicon gate process technology, this device operates from a single 5 V ± 10% power supply. Advanced circuit technology provides both high speed and low power at an operating current of 5 mA/MHz (typ) and a minimum cycle time of 70 ns. It is automatically placed in low-power mode at 1 μA standby current (typ) when chip enable (CE1) is asserted high or (CE2) is asserted low. There are three control inputs. CE1 and CE2 are used to select the device and for data retention control, and output enable (OE) provides fast memory access. This device is well suited to various microprocessor system applications where high speed, low power and battery backup are required. And, with a guaranteed operating range of - 40° to 85°C, the TC551001CPI/CFI/CFTI/CTRI/CSTI/CSRI can be used in environments exhibiting extreme temperature conditions. The TC551001CPI/CFI/CFTI/CTRI/CSTI/CSRI is available in a standard plastic 32-pin dual-in-line package (DIP), plastic 32-pin small-outline package (SOP) and normal and reverse pinout plastic 32-pin thin-small-outline package (TSOP).

FEATURES

- Low-power dissipation
Operating: 27.5 mW/MHz (typical)
- Single power supply voltage of 5 V ± 10%
- Power down features using CE1 and CE2.
- Data retention supply voltage of 2 to 5.5 V
- Direct TTL compatibility for all inputs and outputs
- Wide operating temperature range of - 40° to 85°C
- Standby Current (maximum) :

	TC551001CPI/CFI/CFTI/CTRI/CSTI/CSRI	
	-70,-85	-70L,-85L
5.5V	200 μA	40 μA
3.0V	100 μA	20 μA

- Access Times (maximum):

	TC551001CPI/CFI/CFTI/CTRI/CSTI/CSRI	
	-70,-70L	-85,-85L
Access Time	70 ns	85 ns
CE1 Access Time	70 ns	85 ns
CE2 Access Time	70 ns	85 ns
OE Access Time	35 ns	45 ns

- Packages:

- DIP32-P-600-2.54 (CPI) (Weight: 4.45 g typ)
- SOP32-P-525-1.27 (CFI) (Weight: 1.04 g typ)
- TSOP I 32-P-0820-0.50 (CFTI) (Weight: 0.34 g typ)
- TSOP I 32-P-0820-0.50A (CTRI) (Weight: 0.34 g typ)
- TSOP I 32-P-0.50 (CSTI) (Weight: 0.24 g typ)
- TSOP I 32-P-0.50A (CSRI) (Weight: 0.24 g typ)

PIN ASSIGNMENT (TOP VIEW)

○ 32 PIN DIP & SOP

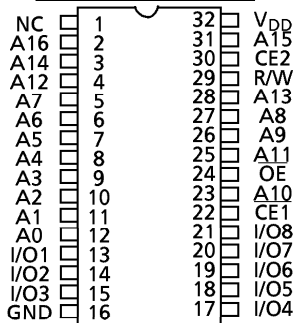

○ 32 PIN TSOP

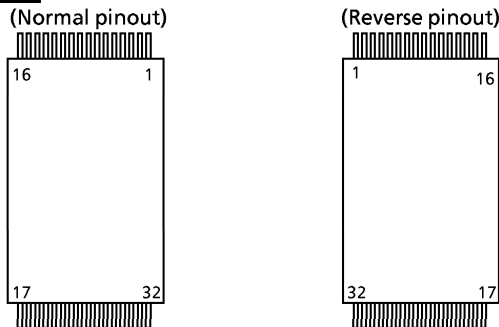

PIN NAMES

A0 to A16	Address Inputs
R/W	Read/Write Control
OE	Output Enable
CE1, CE2	Chip Enable
I/O1 to I/O8	Data Input/Output
VDD	Power (+ 5V)
GND	Ground
NC	No Connection

Pin No.	1	2	3	4	5	6	7	8	9	10	11	12	13	14	15	16
Pin Name	A ₁₁	A ₉	A ₈	A ₁₃	R/W	CE2	A ₁₅	V _{DD}	NC	A ₁₆	A ₁₄	A ₁₂	A ₇	A ₆	A ₅	A ₄
Pin No.	17	18	19	20	21	22	23	24	25	26	27	28	29	30	31	32
Pin Name	A ₃	A ₂	A ₁	A ₀	I/O1	I/O2	I/O3	GND	I/O4	I/O5	I/O6	I/O7	I/O8	CE1	A ₁₀	OE

961001EBA1

- TOSHIBA is continually working to improve the quality and the reliability of its products. Nevertheless, semiconductor devices in general can malfunction or fail due to their inherent electrical sensitivity and vulnerability to physical stress. It is the responsibility of the buyer, when utilizing TOSHIBA products, to observe standards of safety, and to avoid situations in which a malfunction or failure of a TOSHIBA product could cause loss of human life, bodily injury or damage to property. In developing your designs, please ensure that TOSHIBA products are used within specified operating ranges as set forth in the most recent products specifications. Also, please keep in mind the precautions and conditions set forth in the TOSHIBA Semiconductor Reliability Handbook.
- The products described in this document are subject to foreign exchange and foreign trade control laws.
- The information contained herein is presented only as a guide for the applications of our products. No responsibility is assumed by TOSHIBA CORPORATION for any infringements of intellectual property or other rights of the third parties which may result from its use. No license is granted by implication or otherwise under any intellectual property or other rights of TOSHIBA CORPORATION or others.
- The information contained herein is subject to change without notice.

BLOCK DIAGRAM

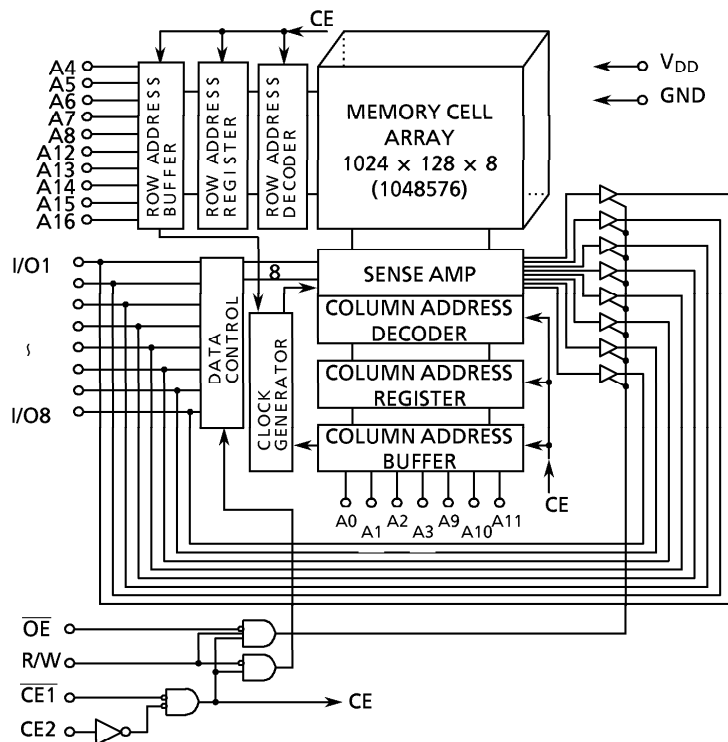

OPERATION MODE

MODE	$\overline{CE1}$	CE2	\overline{OE}	R/W	I/O1 to I/O8	POWER
Read	L	H	L	H	D _{OUT}	I _{DDO}
Write	L	H	x	L	D _{IN}	I _{DDO}
Outputs Disabled	L	H	H	H	High-Z	I _{DDO}
Standby	H	x	x	x	High-Z	I _{DDS}
	x	L	x	x	High-Z	I _{DDS}

Note: x = don't care. H = logic high. L = logic low.

ABSOLUTE MAXIMUM RATINGS

SYMBOL	RATING	VALUE	UNIT
V _{DD}	Power Supply Voltage	- 0.3 to 7.0	V
V _{IN}	Input Voltage	- 0.3* to 7.0	V
V _{I/O}	Input and Output Voltage	- 0.5 to V _{DD} + 0.5	V
P _D	Power Dissipation	1.0/0.6**	W
T _{solder}	Soldering Temperature (10 s)	260	°C
T _{strg.}	Storage Temperature	- 55 to 150	°C
T _{opr.}	Operating Temperature	- 40 to 85	°C

* - 3.0 V when measured at a pulse width of 50 ns

** SOP

DC RECOMMENDED OPERATING CONDITIONS (Ta = - 40° to 85°C)

SYMBOL	PARAMETER	MIN	TYP	MAX	UNIT
V _{DD}	Power Supply Voltage	4.5	5.0	5.5	V
V _{IH}	Input High Voltage	2.4	-	V _{DD} + 0.3	
V _{IL}	Input Low Voltage	- 0.3*	-	0.6	
V _{DH}	Data Retention Supply Voltage	2.0	-	5.5	

* - 3.0 V when measured at a pulse width of 50 ns

DC CHARACTERISTICS (Ta = - 40° to 85°C, V_{DD} = 5 V ± 10%)

SYMBOL	PARAMETER	TEST CONDITION		MIN	TYP	MAX	UNIT	
I _{IL}	Input Leakage Current	V _{IN} = 0 V to V _{DD}		-	-	± 1.0	μA	
I _{OH}	Output High Current	V _{OH} = 2.4 V		- 1.0	-	-	mA	
I _{OL}	Output Low Current	V _{OL} = 0.4 V		4.0	-	-	mA	
I _{LO}	Output Leakage Current	CE1 = V _{IH} or CE2 = V _{IL} or R/W = V _{IL} or OE = V _{IH} , V _{OUT} = 0 V to V _{DD}		-	-	± 1.0	μA	
I _{DDO1}	Operating Current	CE1 = V _{IL} and CE2 = V _{IH} and R/W = V _{IH} , I _{OUT} = 0 mA Other Inputs = V _{IH} /V _{IL}	Tcycle	min	-	-	70	mA
				1 μs	-	-	20	
I _{DDO2}	Operating Current	CE1 = 0.2 V and CE2 = V _{DD} - 0.2 V R/W = V _{DD} - 0.2 V, I _{OUT} = 0 mA Other Inputs = V _{DD} - 0.2 V/0.2 V	Tcycle	min	-	-	60	mA
				1 μs	-	-	10	
I _{DDS1}	Standby Current	CE1 = V _{IH} or CE2 = V _{IL}		-	-	3	mA	
I _{DDS2} (Note)		CE1 = V _{DD} - 0.2 V or CE2 = 0.2 V V _{DD} = 2.0 to 5.5 V	-70, -85	Ta = 25°C	-	1	-	μA
				Ta = -40° to 85°C	-	-	200	
			-70L, -85L	Ta = 25°C	-	1	2	
Ta = -40° to 85°C	-	-		40				

Note: In standby mode with CE1 ≥ V_{DD} - 0.2 V, these limits are assured for the condition CE2 ≥ V_{DD} - 0.2 V or CE2 ≤ 0.2 V.

CAPACITANCE (Ta = 25°C, f = 1 MHz)

SYMBOL	PARAMETER	TEST CONDITION	MAX	UNIT
C _{IN}	Input Capacitance	V _{IN} = GND	10	pF
C _{OUT}	Output Capacitance	V _{OUT} = GND	10	

Note: This parameter is periodically sampled and is not 100% tested.

AC CHARACTERISTICS AND OPERATING CONDITIONS ($T_a = -40^\circ$ to 85°C , $V_{DD} = 5\text{ V} \pm 10\%$)

READ CYCLE

SYMBOL	PARAMETER	TC551001CPI/CFI/CFTI/CTRI/CSTI/CSRI				UNIT
		-70, -70L		-85, -85L		
		MIN	MAX	MIN	MAX	
t_{RC}	Read Cycle Time	70	-	85	-	ns
t_{ACC}	Address Access Time	-	70	-	85	
t_{CO1}	Chip Enable (CE1) Access Time	-	70	-	85	
t_{CO2}	Chip Enable (CE2) Access Time	-	70	-	85	
t_{OE}	Output Enable Access Time	-	35	-	45	
t_{COE}	Chip Enable Low to Output Active	5	-	5	-	
t_{OEE}	Output Enable Low to Output Active	0	-	0	-	
t_{OD}	Chip Enable High to Output High-Z	-	30	-	35	
t_{ODO}	Output Enable High to Output High-Z	-	30	-	35	
t_{OH}	Output Data Hold Time	10	-	10	-	

WRITE CYCLE

SYMBOL	PARAMETER	TC551001CPI/CFI/CFTI/CTRI/CSTI/CSRI				UNIT
		-70, -70L		-85, -85L		
		MIN	MAX	MIN	MAX	
t_{WC}	Write Cycle Time	70	-	85	-	ns
t_{WP}	Write Pulse Width	50	-	60	-	
t_{CW}	Chip Enable to End of Write	60	-	75	-	
t_{AS}	Address Setup Time	0	-	0	-	
t_{WR}	Write Recovery Time	0	-	0	-	
t_{ODW}	R/W Low to Output High-Z	-	30	-	35	
t_{OEW}	R/W High to Output Active	0	-	0	-	
t_{DS}	Data Setup Time	30	-	35	-	
t_{DH}	Data Hold Time	0	-	0	-	

AC TEST CONDITIONS

Output load: 100 pF + one TTL gate
 Input pulse level: 0.4 V, 2.6 V
 Timing measurements: 1.5 V
 Reference level: 1.5 V
 t_R, t_F : 5 ns

TIMING DIAGRAMS

READ CYCLE (See Note 1)

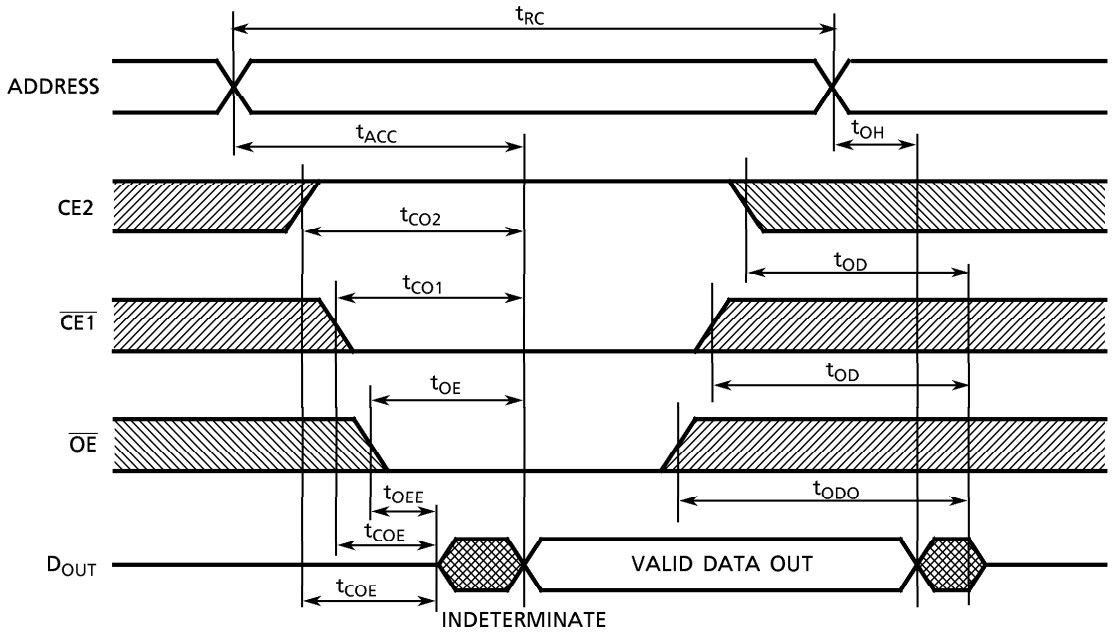

WRITE CYCLE 1 (R/W CONTROLLED) (See Note 4)

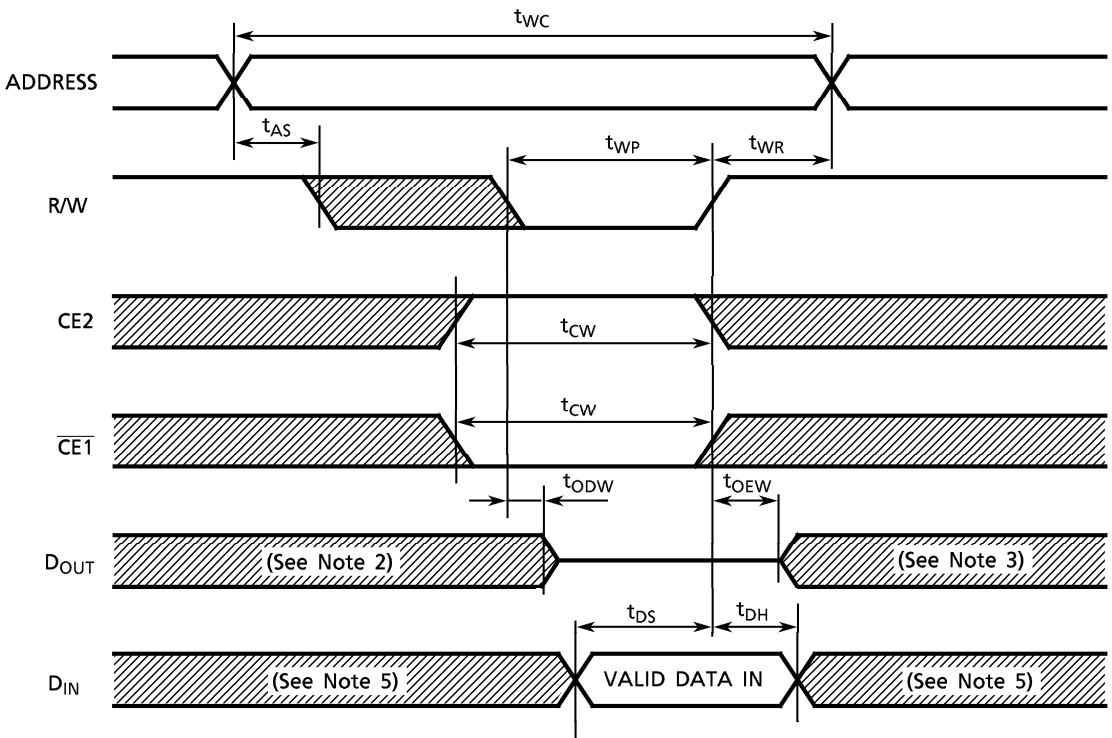

WRITE CYCLE 2 (CE1 CONTROLLED) (See Note 4)

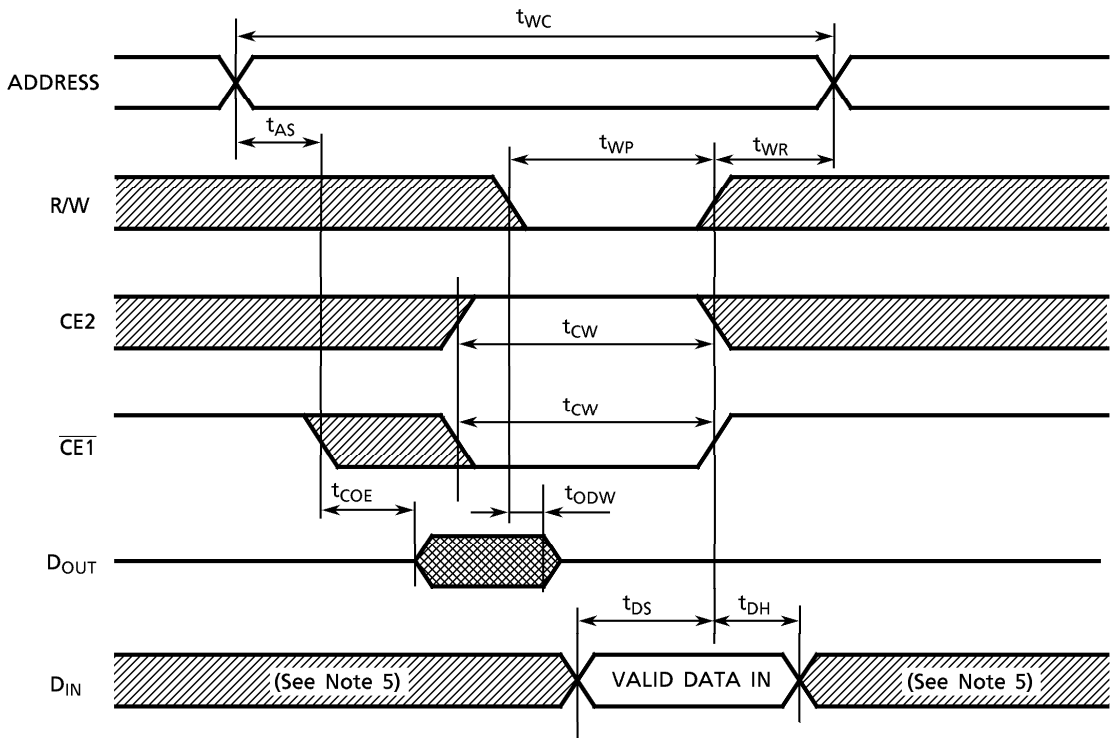

WRITE CYCLE 3 (CE2 CONTROLLED) (See Note 4)

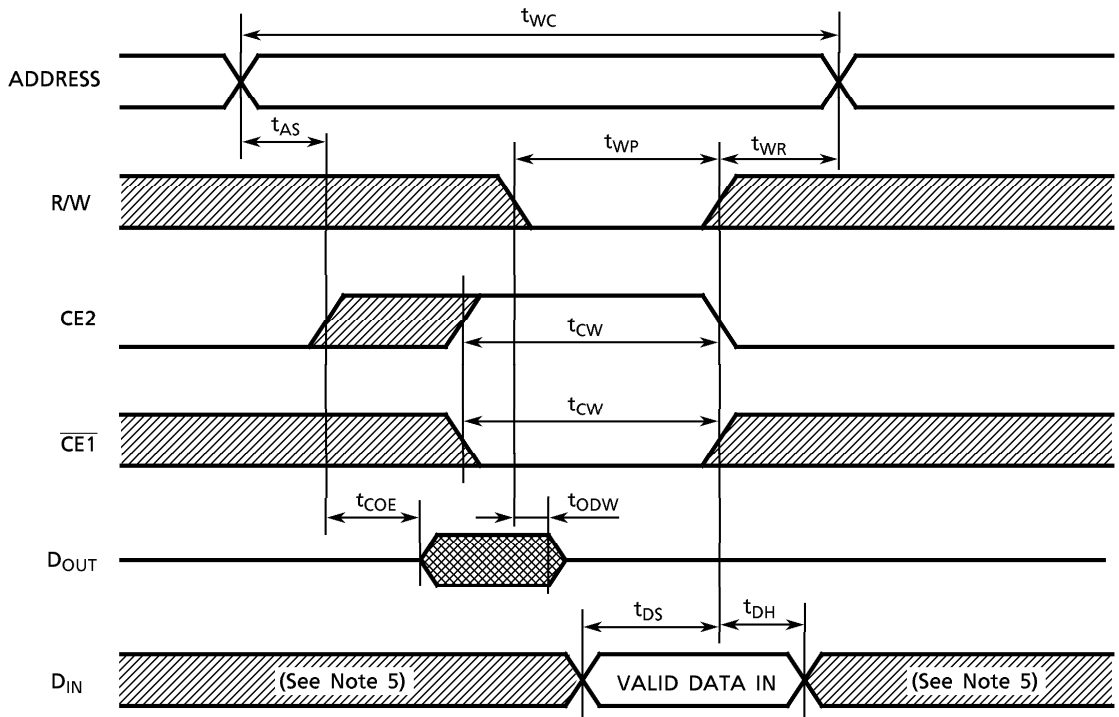

Note: (1) R/W remains HIGH for the read cycle.

(2) If $\overline{CE1}$ goes LOW (or CE2 goes HIGH) coincident with or after R/W goes LOW, the outputs will remain at high impedance.

(3) If $\overline{CE1}$ goes HIGH (or CE2 goes LOW) coincident with or before R/W goes HIGH, the outputs will remain at high impedance.

(4) If \overline{OE} is HIGH during the write cycle, the outputs will remain at high impedance.

(5) Because I/O signals may be in the output state at this time, input signals of reverse polarity must not be applied.

DATA RETENTION CHARACTERISTICS (Ta = - 40° to 85°C)

SYMBOL	PARAMETER		MIN	TYP	MAX	UNIT	
V _{DH}	Data Retention Supply Voltage		2.0	-	5.5	V	
I _{DDS2}	Standby Current	-70, -85	V _{DH} = 3.0 V	-	-	100	μA
			V _{DH} = 5.5 V	-	-	200	
		-70L, -85L	V _{DH} = 3.0 V	-	-	20*	
			V _{DH} = 5.5 V	-	-	40	
t _{CDR}	Chip Deselect to Data Retention Mode Time		0	-	-	nS	
t _R	Recovery Time		5	-	-	mS	

* 2 μA (max) at Ta = - 40° to 40°C

CE1 CONTROLLED DATA RETENTION MODE (See Note 1)

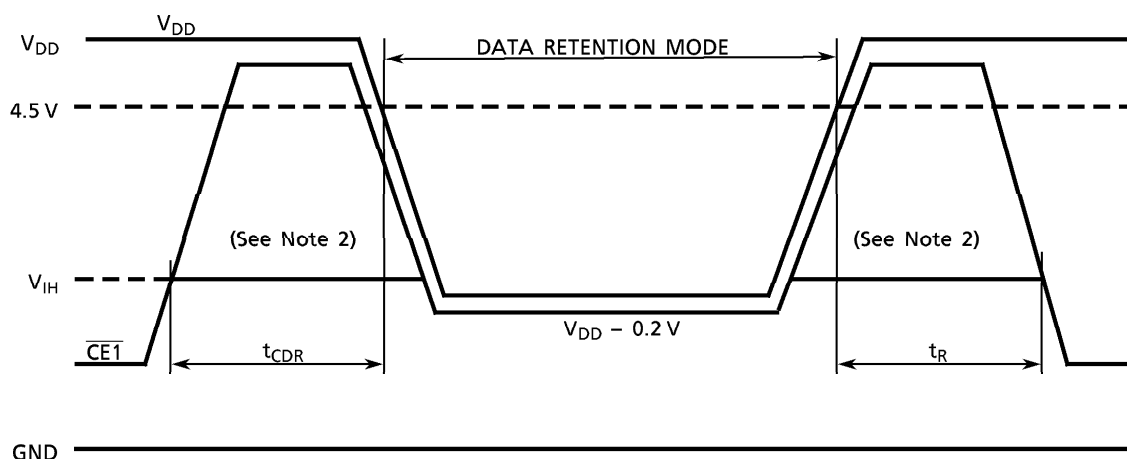

CE2 CONTROLLED DATA RETENTION MODE (See Note 3)

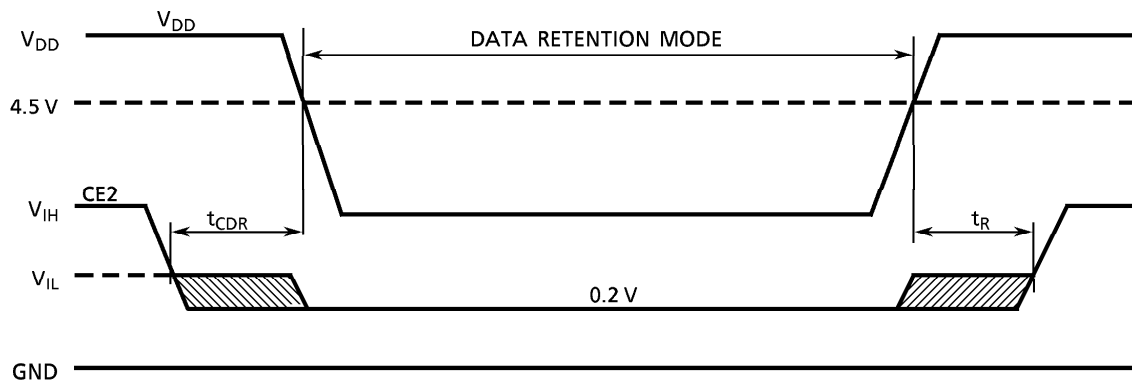

- Note: (1) In $\overline{CE1}$ controlled data retention mode, minimum standby current mode is entered when $CE2 \leq 0.2\text{ V}$ or $CE2 \geq V_{DD} - 0.2\text{ V}$.
- (2) When $\overline{CE1}$ is operating at the V_{IH} level (2.4 V), the operation current is given by I_{DDSI} during the transition of V_{DD} from 4.5 to 2.6 V.
- (3) In $CE2$ controlled data retention mode, minimum standby current mode is entered when $CE2 \leq 0.2\text{ V}$.

PACKAGE DIMENSIONS (DIP32-P-600-2.54)

Units in mm

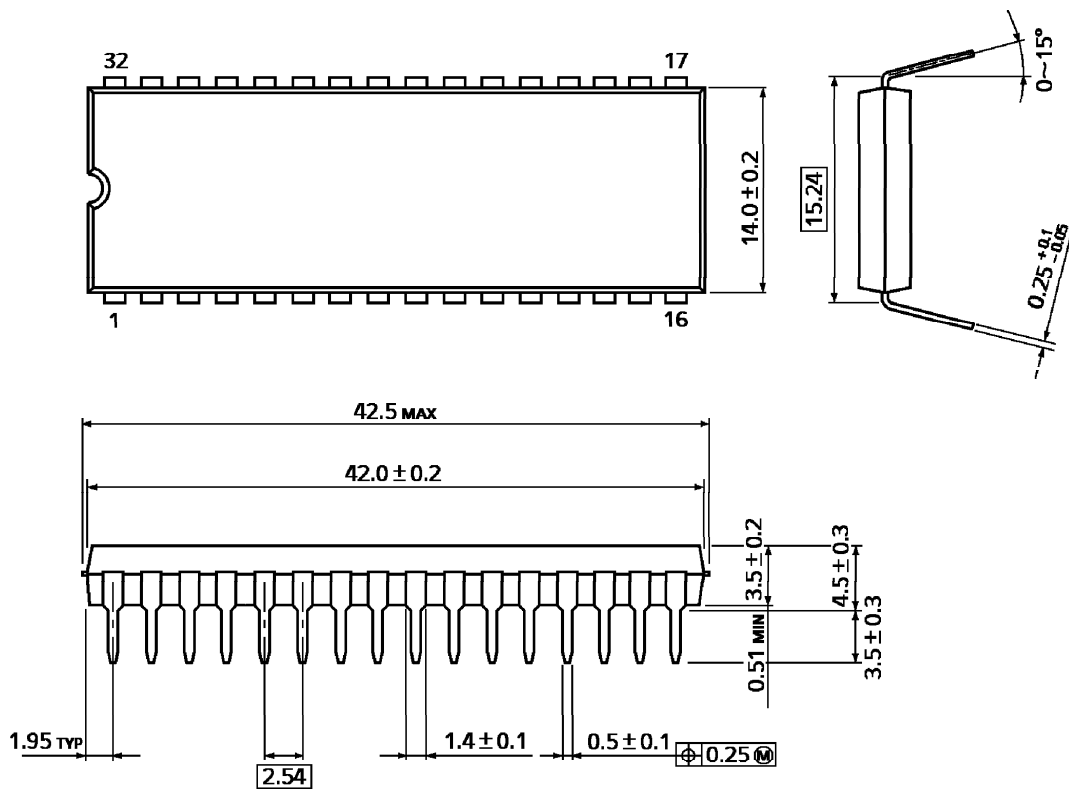

Weight: 4.45 g (typ)

PACKAGE DIMENSIONS (SOP32-P-525-1.27)

Units in mm

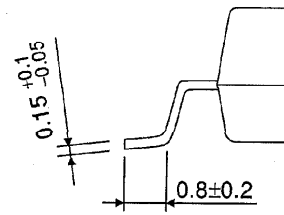
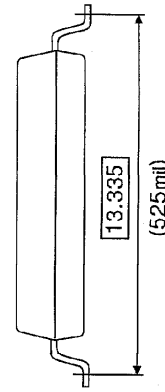
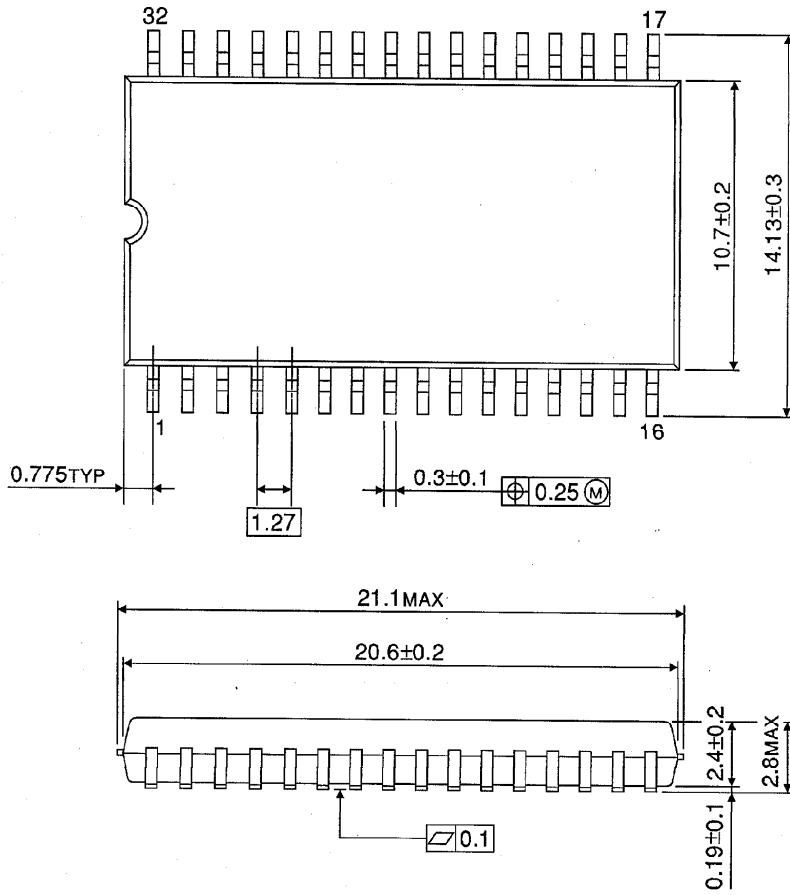

Weight: 1.04 g (typ)

PACKAGE DIMENSIONS (TSOP I 32-P-0820-0.50)

Units in mm

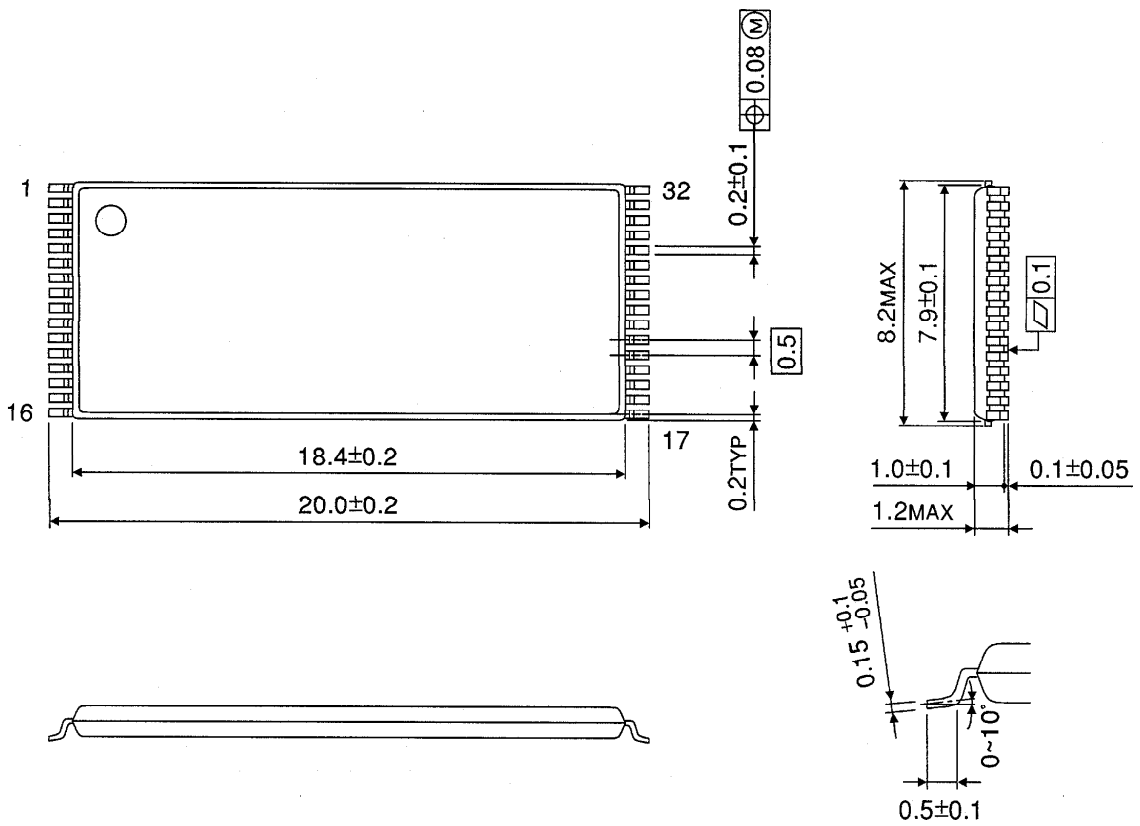

Weight: 0.34 g (typ)

PACKAGE DIMENSIONS (TSOP I 32-P-0820-0.50A)

Units in mm

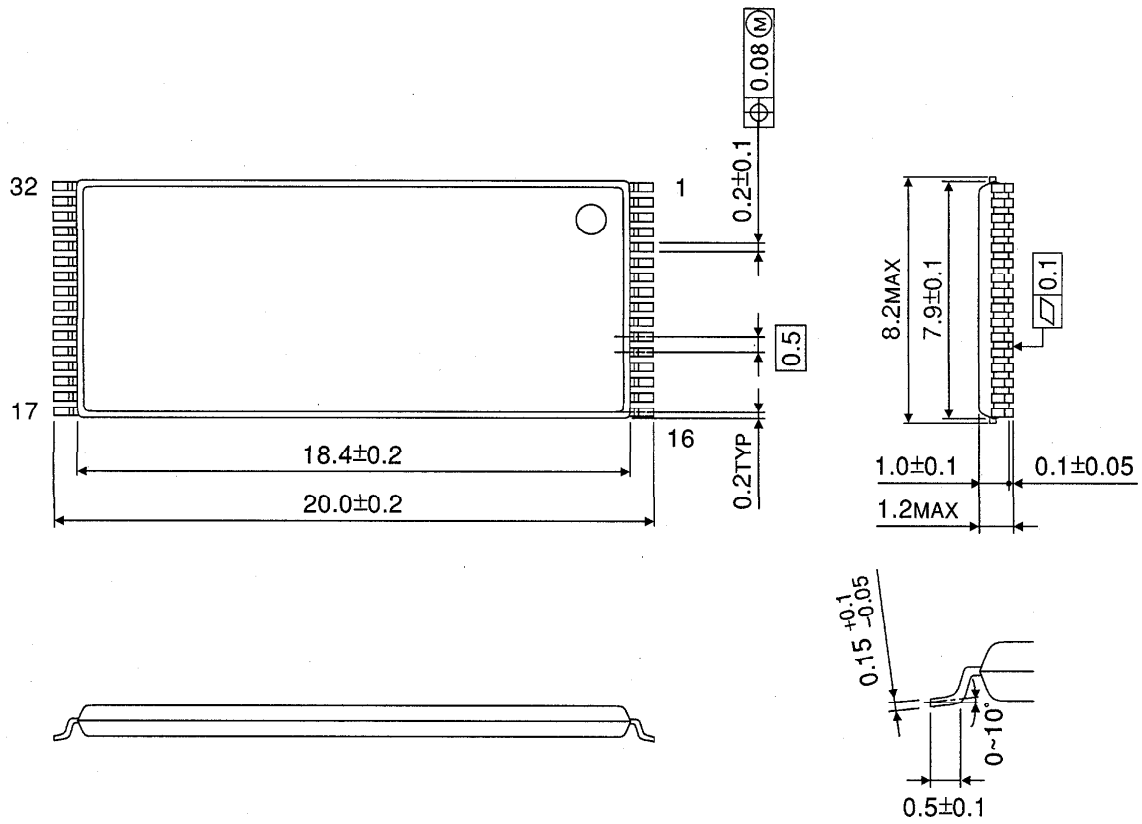

Weight: 0.34 g (typ)

PACKAGE DIMENSIONS (TSOP I 32-P-0.50)

Units in mm

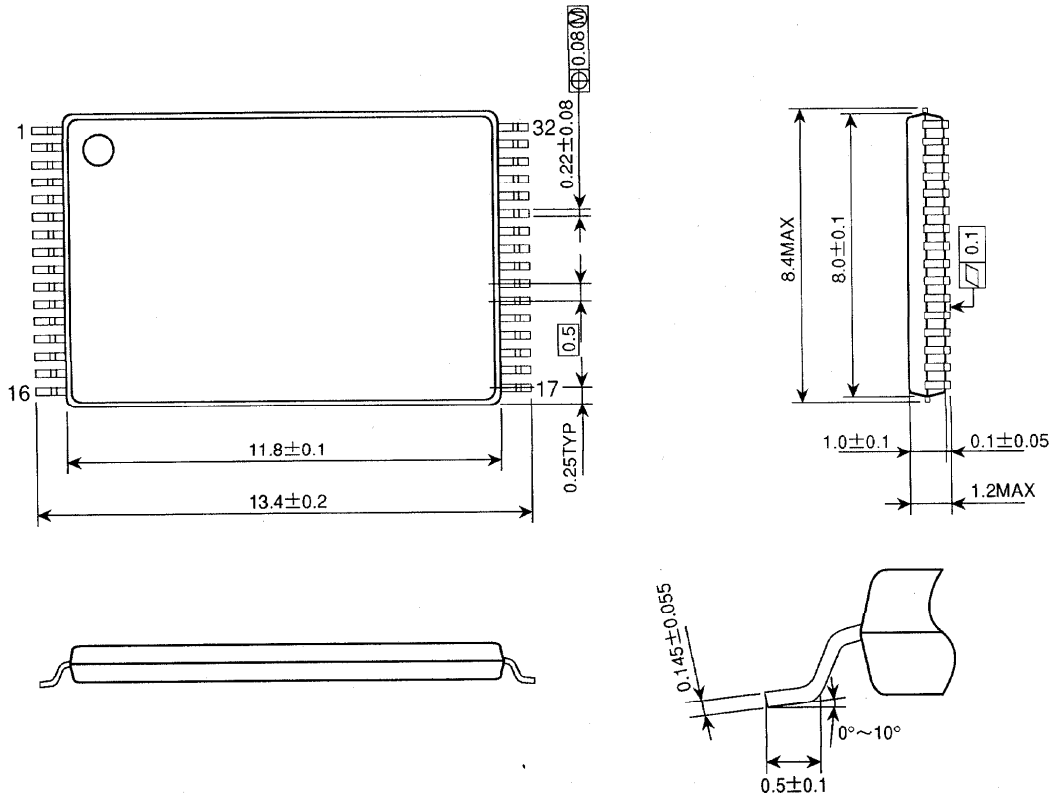

Weight: 0.24 g (typ)

PACKAGE DIMENSIONS (TSOP I 32-P-0.50A)

Units in mm

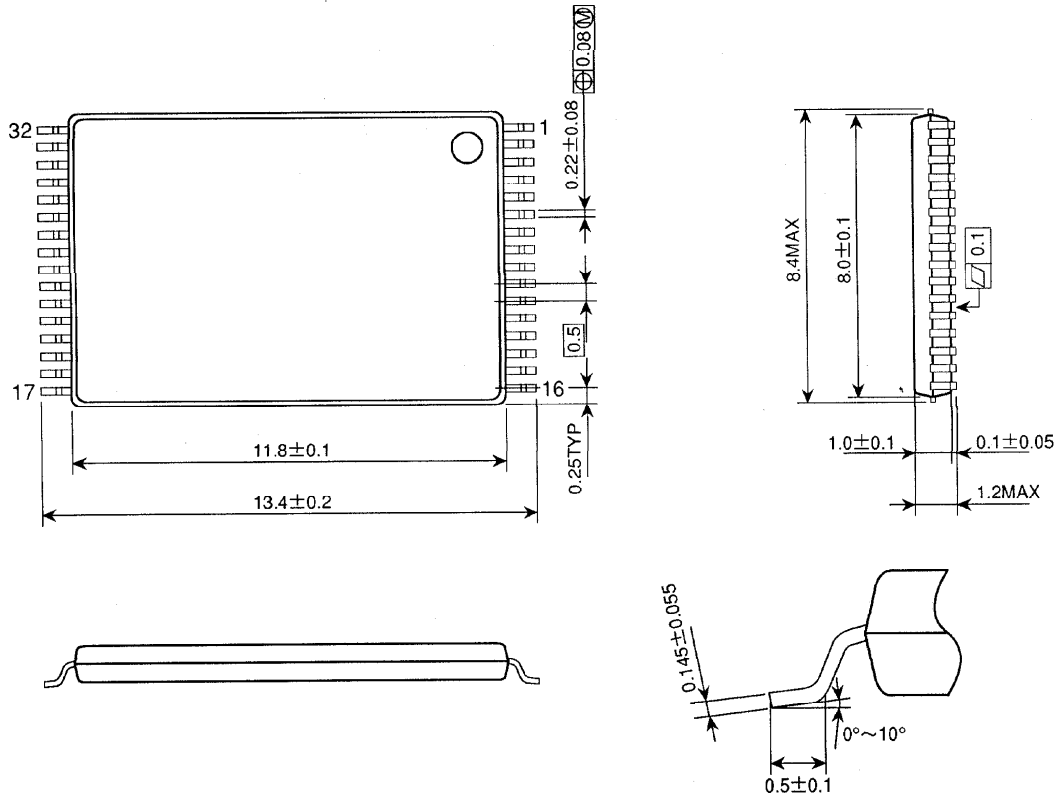

Weight: 0.24 g (typ)