

TC4W53F, TC4W53FU

2-CHANNEL MULTIPLEXER / DEMULTIPLEXER

The TC4W53 is multiplexer with capabilities of selection and mixture of analog signal and digital signal. TC4W53F has 2 channel configuration. The digital signal to the control terminal turns "ON" the corresponding switch of each channel, with large amplitude ($V_{DD}-V_{EE}$) can be switched by the control signal with small logical amplitude ($V_{DD}-V_{SS}$). For example, in the case of $V_{DD}=5V$, $V_{SS}=0V$ and $V_{EE}=-5V$, signals between $-5V$ and $+5V$ can be switched from the logical circuit with signal power supply of 5 volts. As the ON-resistance of each switch is low, these can be connected to the circuits with low input impedance.

MAXIMUM RATINGS

CHARACTERISTIC	SYMBOL	RATING	UNIT
DC Supply Voltage	$V_{DD}-V_{SS}$	$-0.5\sim 20$	V
DC Supply Voltage	$V_{DD}-V_{EE}$	$-0.5\sim 20$	V
Control Input Voltage	V_{CIN}	$V_{SS}-0.5\sim V_{DD}+0.5$	V
Switch I/O Voltage	V_I/V_O	$V_{EE}-0.5\sim V_{DD}+0.5$	V
Control Input Current	I_{CIN}	± 10	mA
Potential difference across I/O during ON	V_{I-O}	$-0.5\sim 0.5$	V
Power Dissipation	P_D	300	mW
Operating Temperature	T_{opr}	$-40\sim 85$	$^{\circ}C$
Storage Temperature	T_{stg}	$-65\sim 150$	$^{\circ}C$
Lead Temperature (10s)	T_L	260	$^{\circ}C$

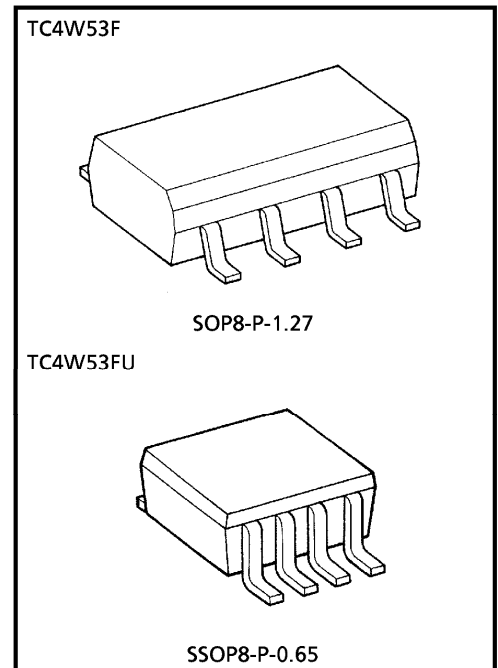

Weight SOP8-P-1.27 : 0.05g (Typ.)
SSOP8-P-0.65 : 0.02g (Typ.)

MARKING

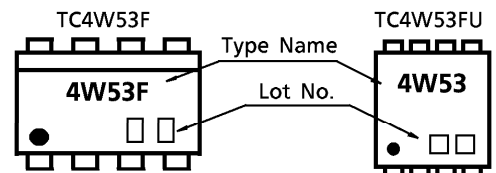

LOGIC DIAGRAM

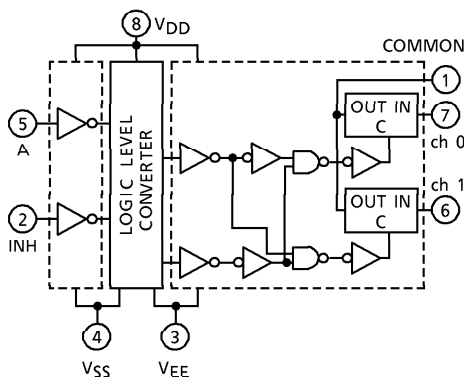

TRUTH TABLE

CONTROL INPUT		ON CHANNEL
INH	A	
L	L	ch 0
L	H	ch 1
H	x	NONE

x : Don't Care

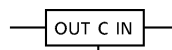

TRUTH TABLE

CONTROL C	IMPE-DANCE BETWEEN IN-OUT
H	$0.5\sim 5 \times 10^2 \Omega$
L	$> 10^9 \Omega$

PIN ASSIGNMENT (TOP VIEW)

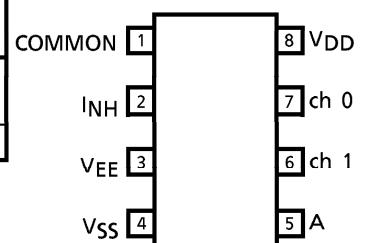

RECOMMENDED OPERATING CONDITIONS

CHARACTERISTIC	SYMBOL		MIN.	TYP.	MAX.	UNIT
DC Supply Voltage	$V_{DD}-V_{SS}$	—	3	—	18	V
	$V_{DD}-V_{EE}$	—	3	—	18	V
Control Input Voltage	V_{IN}	—	V_{SS}	—	V_{DD}	V
Input/Output Voltage	$V_{IN}-V_{OUT}$	—	V_{EE}	—	V_{DD}	V

DC ELECTRICAL CHARACTERISTICS

CHARACTERISTIC	SYM-BOL	TEST CONDITION			- 40°C		25°C			85°C		UNIT
		V_{SS} (V)	V_{EE} (V)	V_{DD} (V)	MIN.	MAX.	MIN.	TYP.	MAX.	MIN.	MAX.	
Control Input High Voltage	V_{IH}	$V_{IS} = V_{DD}$ thru $1k\Omega$	$V_{EE} = V_{SS}$ $R_L = 1k\Omega$ to V_{SS} $I_{LS} < 2\mu A$ on all OFF Channels	5	3.5	—	3.5	2.75	—	3.5	—	V
				10	7.0	—	7.0	5.50	—	7.0	—	
				15	11.0	—	11.0	8.25	—	11.0	—	
Control Input Low Voltage	V_{IL}			5	—	1.5	—	2.25	1.5	—	1.5	V
				10	—	3.0	—	4.5	3.0	—	3.0	
				15	—	4.0	—	6.75	4.0	—	4.0	
On-State Resistance	R_{ON}	$0 \leq V_{IS} \leq V_{DD}$ $R_L = 10k\Omega$		5	—	850	—	240	950	—	1200	Ω
				10	—	210	—	110	250	—	300	
				15	—	140	—	80	160	—	200	
Δ ON-State Resistance Between 2 Switches	ΔR_{ON}	—		5	—	—	—	10	—	—	—	Ω
				10	—	—	—	6	—	—	—	
				15	—	—	—	4	—	—	—	
Input/Output Leakage Current	I_{OFF}	$V_{IN} = 18V, V_{OUT} = 0V$ $V_{IN} = 0V, V_{OUT} = 18V$		18	—	± 100	—	± 0.01	± 100	—	± 1000	nA
				18	—	± 100	—	± 0.01	± 100	—	± 1000	
Quiescent Device Current	I_{DD}	$V_{IN} = V_{SS}, V_{DD} *$		5	—	5.0	—	0.005	5.0	—	150	μA
				10	—	10	—	0.010	10	—	300	
				15	—	20	—	0.015	20	—	600	
Input Current	I_{IN}	$V_{IH} = 18V, V_{IL} = 0V$		18	—	0.1	—	10^{-5}	0.1	—	1.0	μA
				18	—	-0.1	—	-10^{-5}	-0.1	—	-1.0	
Input Capacitance	C_{IN}	—	—	—	—	—	—	5	7.5	—	—	pF
Switch Input Capacitance	C_{IN}	—	—	—	—	—	—	10	—	—	—	pF
Switch Output Capacitance	C_{OUT}	—	—	—	—	—	—	17	—	—	—	
Feedthrough Capacitance	C_{IN-OUT}	—	—	—	—	—	—	0.2	—	—	—	

* All valid input combinations.

AC ELECTRICAL CHARACTERISTICS (Ta = 25°C, CL = 50pF)

CHARACTERISTIC	SYMBOL	TEST CONDITION	TEST CONDITION			MIN.	TYP.	MAX.	UNIT
			VSS (V)	VEE (V)	VDD (V)				
Phase difference between input to output	ϕ_{I-O}	—	0	0	5	—	15	45	ns
			0	0	10	—	8	20	
			0	0	15	—	6	15	
Propagation Delay Time (A-OUT)	t_{pZL} t_{pZH} t_{pLZ} t_{pHZ}	$R_L = 1k\Omega$	0	0	5	—	170	550	ns
			0	0	10	—	90	240	
			0	0	15	—	70	160	
			0	-5	5	—	100	240	
			0	-7.5	7.5	—	80	160	
Propagation Delay Time (INH-OUT)	t_{pZL} t_{pZH}	$R_L = 1k\Omega$	0	0	5	—	120	380	ns
			0	0	10	—	60	200	
			0	0	15	—	50	160	
			0	-5	5	—	80	200	
			0	-7.5	7.5	—	60	160	
Propagation Delay Time (INH-OUT)	t_{pLZ} t_{pHZ}	$R_L = 1k\Omega$	0	0	5	—	170	450	ns
			0	0	10	—	90	210	
			0	0	15	—	70	160	
			0	-5	5	—	100	210	
			0	-7.5	7.5	—	80	160	
-3dB Cutoff Frequency	$f_{MAX(I-O)}$	$R_L = 1k\Omega$ (*1)	-5	-5	5	—	40	—	MHz
Total Harmonic Distortion	—	$R_L = 10k\Omega$ $f = 1kHz$ (*2)	-2.5	-2.5	2.5	—	0.15	—	%
			-5	-5	5	—	0.03	—	
			-7.5	-7.5	7.5	—	0.02	—	
-50dB Feedthrough (Switch OFF)	—	$R_L = 1k\Omega$ (*3)	-5	-5	5	—	500	—	kHz
Crosstalk (CONTROL-OUT)	—	$R_{IN} = 1k\Omega$ $R_{OUT} = 10k\Omega$ $C_L = 15pF$	0	0	5	—	200	—	mV
			0	0	10	—	400	—	
			0	0	15	—	600	—	

*1 Sine wave of $\pm 2.5V_{p-p}$ shall be used for V_{IS} and the frequency of $20\log_{10} \frac{V_{OS}}{V_{IS}}$ = -3dB shall be f_{MAX} .

*2 V_{IS} shall be sine wave of $\pm \left(\frac{V_{DD} - V_{EE}}{4} \right) p-p$.

*3 Sine wave of $\pm 2.5V_{p-p}$ shall be used for V_{IS} and the frequency of $20\log_{10} \frac{V_{OS}}{V_{IS}}$ = -50dB shall be feed-through.

PACKAGE DIMENSIONS
SOP8-P-1.27

Unit : mm

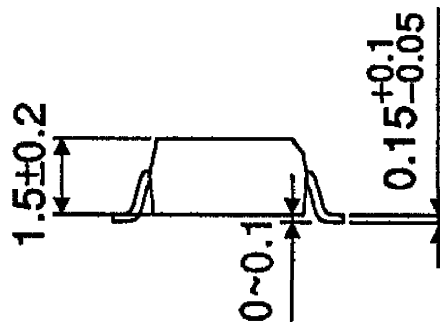
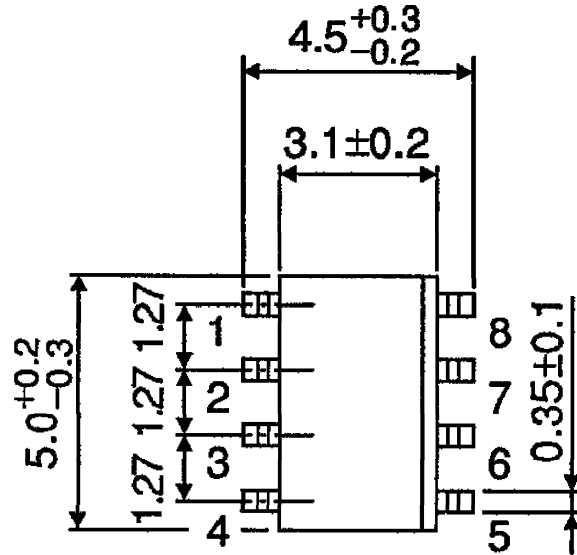

Weight : 0.05g (Typ.)

PACKAGE DIMENSIONS
SSOP8-P-0.65

Unit : mm

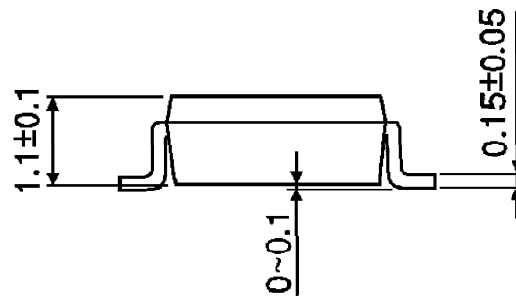
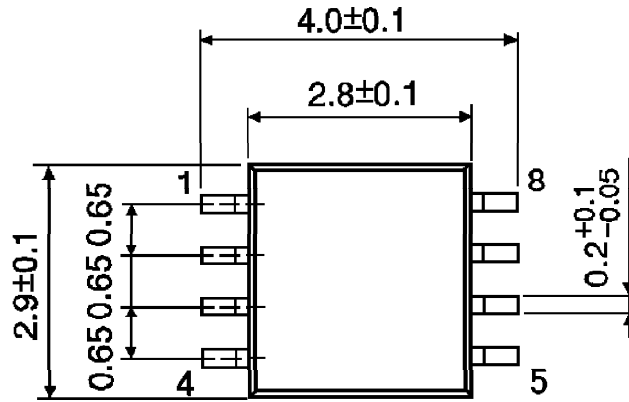

Weight : 0.02g (Typ.)

RESTRICTIONS ON PRODUCT USE

000707EBA

- TOSHIBA is continually working to improve the quality and reliability of its products. Nevertheless, semiconductor devices in general can malfunction or fail due to their inherent electrical sensitivity and vulnerability to physical stress. It is the responsibility of the buyer, when utilizing TOSHIBA products, to comply with the standards of safety in making a safe design for the entire system, and to avoid situations in which a malfunction or failure of such TOSHIBA products could cause loss of human life, bodily injury or damage to property. In developing your designs, please ensure that TOSHIBA products are used within specified operating ranges as set forth in the most recent TOSHIBA products specifications. Also, please keep in mind the precautions and conditions set forth in the "Handling Guide for Semiconductor Devices," or "TOSHIBA Semiconductor Reliability Handbook" etc..
- The TOSHIBA products listed in this document are intended for usage in general electronics applications (computer, personal equipment, office equipment, measuring equipment, industrial robotics, domestic appliances, etc.). These TOSHIBA products are neither intended nor warranted for usage in equipment that requires extraordinarily high quality and/or reliability or a malfunction or failure of which may cause loss of human life or bodily injury ("Unintended Usage"). Unintended Usage include atomic energy control instruments, airplane or spaceship instruments, transportation instruments, traffic signal instruments, combustion control instruments, medical instruments, all types of safety devices, etc.. Unintended Usage of TOSHIBA products listed in this document shall be made at the customer's own risk.
- The products described in this document are subject to the foreign exchange and foreign trade laws.
- The information contained herein is presented only as a guide for the applications of our products. No responsibility is assumed by TOSHIBA CORPORATION for any infringements of intellectual property or other rights of the third parties which may result from its use. No license is granted by implication or otherwise under any intellectual property or other rights of TOSHIBA CORPORATION or others.
- The information contained herein is subject to change without notice.