

TC4013BP, TC4013BF, TC4013BFN

TC4013B Dual D-Type Flip Flop

TC4013B contains two independent circuits of D type flip-flop. The input level applied to DATA input are transferred to Q and \bar{Q} output by rising edge of the clock pulse. When SET input is placed at "H", and RESET input is placed at "L", outputs become Q = "H", and \bar{Q} = "L". When RESET input is placed at "H", and SET input is placed at "L", outputs become Q = "L", and \bar{Q} = "H". When both of RESET input and SET input are at "H", outputs become Q = "H" and \bar{Q} = "H".

Pin Assignment

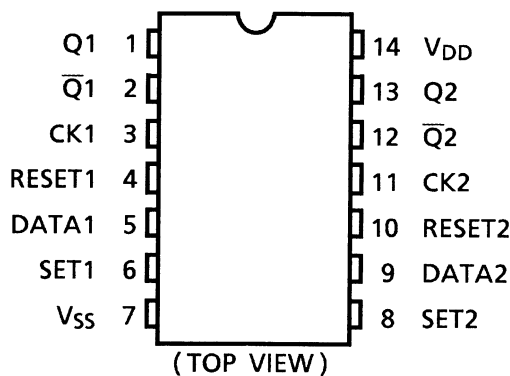

Block Diagram

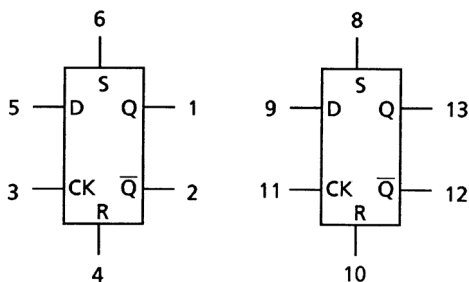

Note: xxxFN (JEDEC SOP) is not available in Japan.

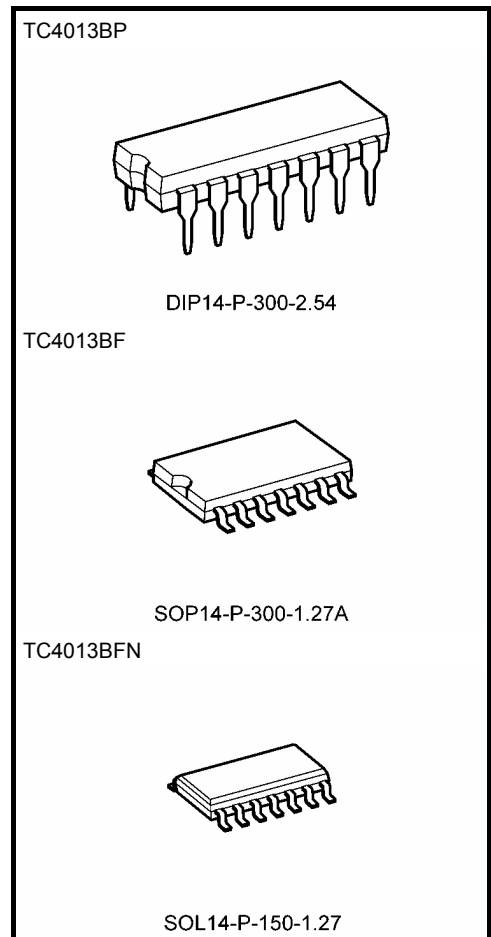

Weight	
DIP14-P-300-2.54	: 0.96 g (typ.)
SOP14-P-300-1.27A	: 0.18 g (typ.)
SOL14-P-150-1.27	: 0.12 g (typ.)

Truth Table

Inputs				Outputs	
RESET	SET	DATA	CK Δ	Q _{n+1}	\bar{Q}_{n+1}
L	H	*	*	H	L
H	L	*	*	L	H
H	H	*	*	H	H
L	L	L	\uparrow	L	H
L	L	H	\uparrow	H	L
L	L	*	\downarrow	Q _n	\bar{Q}_n

*: Don't care

Δ : Level change

\cdot : No change

Logic Diagram

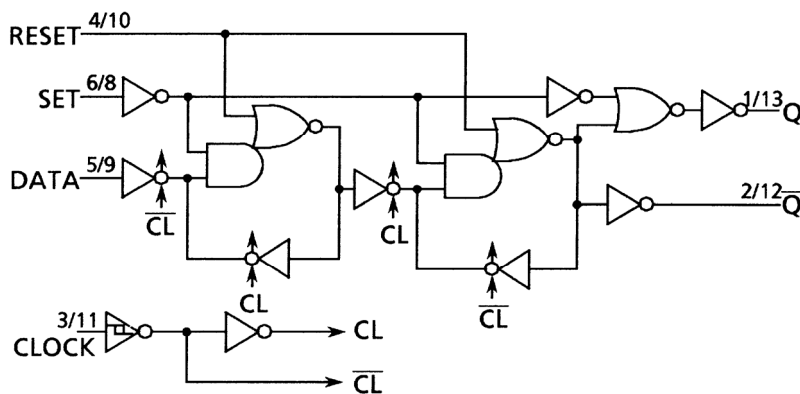

Absolute Maximum Ratings (Note)

Characteristics	Symbol	Rating	Unit
DC supply voltage	V _{DD}	V _{SS} - 0.5~V _{SS} + 20	V
Input voltage	V _{IN}	V _{SS} - 0.5~V _{DD} + 0.5	V
Output voltage	V _{OUT}	V _{SS} - 0.5~V _{DD} + 0.5	V
DC input current	I _{IN}	±10	mA
Power dissipation	P _D	300 (DIP)/180 (SOIC)	mW
Operating temperature range	T _{opr}	-40~85	°C
Storage temperature range	T _{stg}	-65~150	°C

Note: Exceeding any of the absolute maximum ratings, even briefly, lead to deterioration in IC performance or even destruction.

Using continuously under heavy loads (e.g. the application of high temperature/current/voltage and the significant change in temperature, etc.) may cause this product to decrease in the reliability significantly even if the operating conditions (i.e. operating temperature/current/voltage, etc.) are within the absolute maximum ratings and the operating ranges.

Please design the appropriate reliability upon reviewing the Toshiba Semiconductor Reliability Handbook ("Handling Precautions"/"Derating Concept and Methods") and individual reliability data (i.e. reliability test report and estimated failure rate, etc).

Operating Ranges ($V_{SS} = 0\text{ V}$) (Note)

Characteristics	Symbol	Test Condition	Min	Typ.	Max	Unit
DC supply voltage	V_{DD}	—	3	—	18	V
Input voltage	V_{IN}	—	0	—	V_{DD}	V

Note: The operating ranges must be maintained to ensure the normal operation of the device.

Unused inputs must be tied to either V_{DD} or V_{SS} .

Static Electrical Characteristics ($V_{SS} = 0\text{ V}$)

Characteristics	Sym- bol	Test Condition	V_{DD} (V)	-40°C		25°C			85°C		Unit	
				Min	Max	Min	Typ.	Max	Min	Max		
High-level output voltage	V_{OH}	$ I_{OUT} < 1\ \mu\text{A}$ $V_{IN} = V_{SS}, V_{DD}$	5	4.95	—	4.95	5.00	—	4.95	—	V	
			10	9.95	—	9.95	10.00	—	9.95	—		
			15	14.95	—	14.95	15.00	—	14.95	—		
Low-level output voltage	V_{OL}	$ I_{OUT} < 1\ \mu\text{A}$ $V_{IN} = V_{SS}, V_{DD}$	5	—	0.05	—	0.00	0.05	—	0.05	V	
			10	—	0.05	—	0.00	0.05	—	0.05		
			15	—	0.05	—	0.00	0.05	—	0.05		
Output high current	I_{OH}	$V_{OH} = 4.6\text{ V}$ $V_{OH} = 2.5\text{ V}$ $V_{OH} = 9.5\text{ V}$ $V_{OH} = 13.5\text{ V}$ $V_{IN} = V_{SS}, V_{DD}$	5	-0.61	—	-0.51	-1.0	—	-0.42	—	mA	
			5	-2.50	—	-2.10	-4.0	—	-1.70	—		
			10	-1.50	—	-1.30	-2.2	—	-1.10	—		
			15	-4.00	—	-3.40	-9.0	—	-2.80	—		
Output low current	I_{OL}	$V_{OL} = 0.4\text{ V}$ $V_{OL} = 0.5\text{ V}$ $V_{OL} = 1.5\text{ V}$ $V_{IN} = V_{SS}, V_{DD}$	5	0.61	—	0.51	1.2	—	0.42	—	mA	
			10	1.50	—	1.30	3.2	—	1.10	—		
			15	4.00	—	3.40	12.0	—	2.80	—		
Input high voltage	V_{IH}	$V_{OUT} = 0.5\text{ V}, 4.5\text{ V}$ $V_{OUT} = 1.0\text{ V}, 9.0\text{ V}$ $V_{OUT} = 1.5\text{ V}, 13.5\text{ V}$ $ I_{OUT} < 1\ \mu\text{A}$	5	3.5	—	3.5	2.75	—	3.50	—	V	
			10	7.0	—	7.0	5.50	—	7.00	—		
			15	11.0	—	11.0	8.25	—	11.00	—		
Input low voltage	V_{IL}	$V_{OUT} = 0.5\text{ V}, 4.5\text{ V}$ $V_{OUT} = 1.0\text{ V}, 9.0\text{ V}$ $V_{OUT} = 1.5\text{ V}, 13.5\text{ V}$ $ I_{OUT} < 1\ \mu\text{A}$	5	—	1.5	—	2.25	1.5	—	1.5	V	
			10	—	3.0	—	4.50	3.0	—	3.0		
			15	—	4.0	—	6.75	4.0	—	4.0		
Input current	"H" level	I_{IH}	$V_{IH} = 18\text{ V}$	18	—	0.1	—	10^{-5}	0.1	—	1.0	μA
	"L" level	I_{IL}	$V_{IL} = 0\text{ V}$	18	—	-0.1	—	-10^{-5}	-0.1	—	-1.0	
Quiescent supply current	I_{DD}	$V_{IN} = V_{SS}, V_{DD}$ (Note)	5	—	1	—	0.002	1	—	30	μA	
			10	—	2	—	0.004	2	—	60		
			15	—	4	—	0.008	4	—	120		

Note: All valid input combinations.

Dynamic Electrical Characteristics (Ta = 25°C, VSS = 0 V, CL = 50 pF)

Characteristics	Symbol	Test Condition	VDD (V)	Min	Typ.	Max	Unit
Output transition time (low to high)	t _{TLH}	—	5	—	70	200	ns
			10	—	35	100	
			15	—	30	80	
Output transition time (high to low)	t _{THL}	—	5	—	70	200	ns
			10	—	35	100	
			15	—	30	80	
Propagation delay time (CK-Q, \bar{Q})	t _{pLH} t _{pHL}	—	5	—	130	300	ns
			10	—	65	130	
			15	—	50	90	
Propagation delay time (SET, RESET-Q, \bar{Q})	t _{pLH}	—	5	—	110	300	ns
			10	—	50	130	
			15	—	40	90	
Propagation delay time (SET, RESET-Q, \bar{Q})	t _{pHL}	—	5	—	110	300	ns
			10	—	50	130	
			15	—	40	90	
Max clock frequency	f _{CL}	—	5	3.5	8	—	MHz
			10	8.0	16	—	
			15	12.0	20	—	
Max clock input rise time Max clock input fall time	t _{rCL} t _{fCL}	—	5	No limit			μs
			10				
			15				
Min pulse width (SET, RESET)	t _w	—	5	—	60	180	ns
			10	—	30	80	
			15	—	25	50	
Min clock pulse width	t _w	—	5	—	60	140	ns
			10	—	30	60	
			15	—	25	40	
Min set-up time (DATA-CK)	t _{su}	—	5	—	—	40	ns
			10	—	—	20	
			15	—	—	15	
Min hold time (DATA-CK)	t _H	—	5	—	20	40	ns
			10	—	10	20	
			15	—	6	15	
Min removal time (SET, RESET-CK)	t _{rem}	—	5	—	—	40	ns
			10	—	—	20	
			15	—	—	15	
Input capacitance	C _{IN}	—		—	5	7.5	pF

Waveform for Measurement of Dynamic Characteristics

Waveform 1

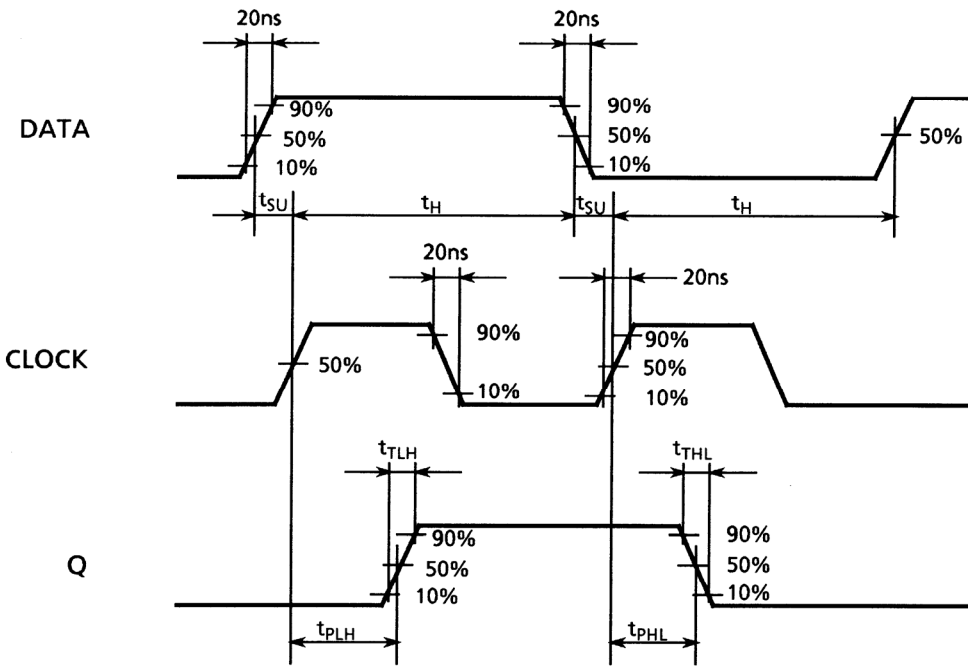

Waveform 2

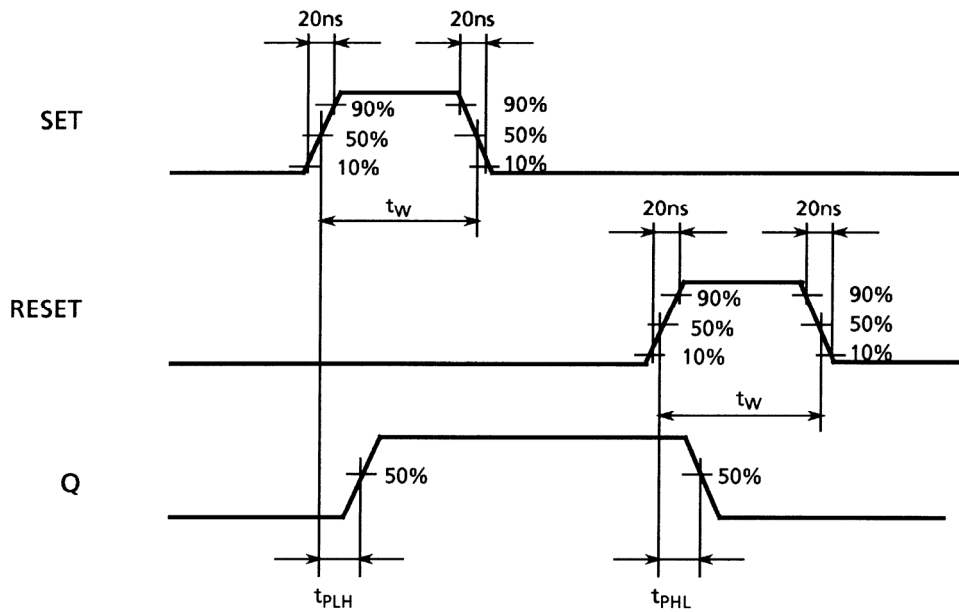

Package Dimensions

DIP14-P-300-2.54

Unit : mm

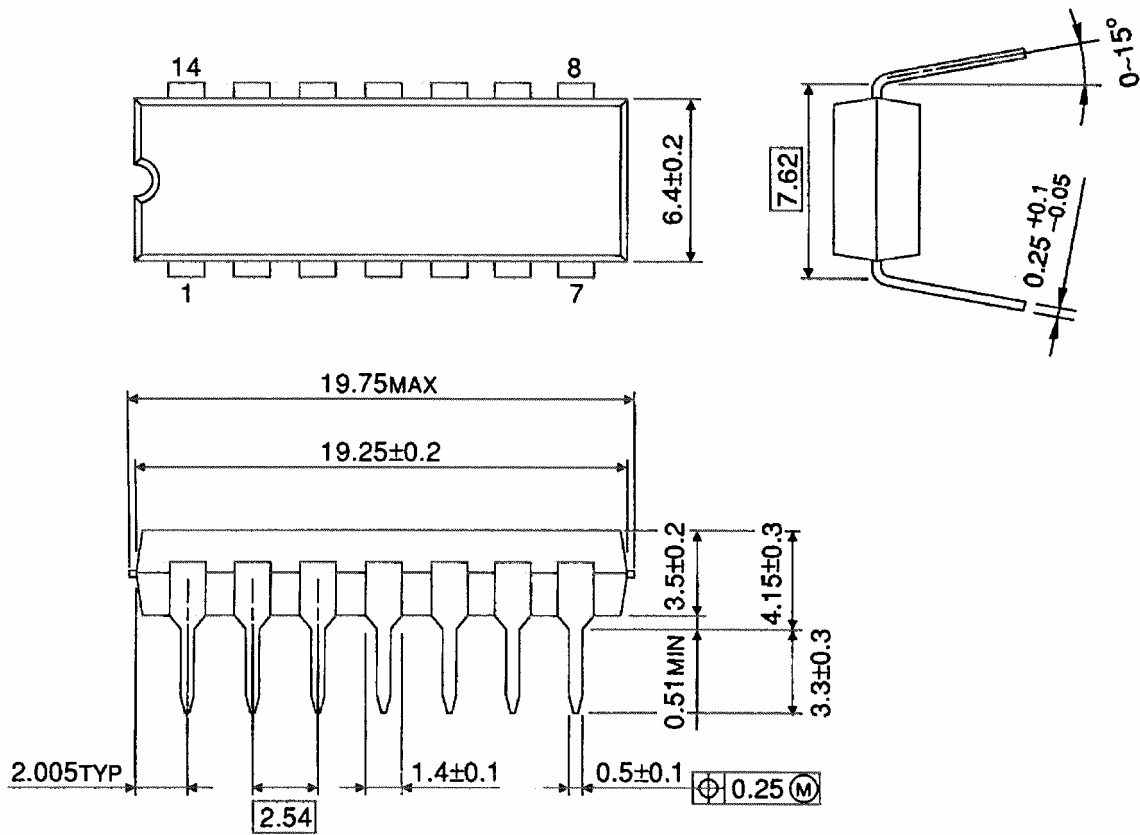

Weight: 0.96 g (typ.)

Package Dimensions

SOP14-P-300-1.27A

Unit: mm

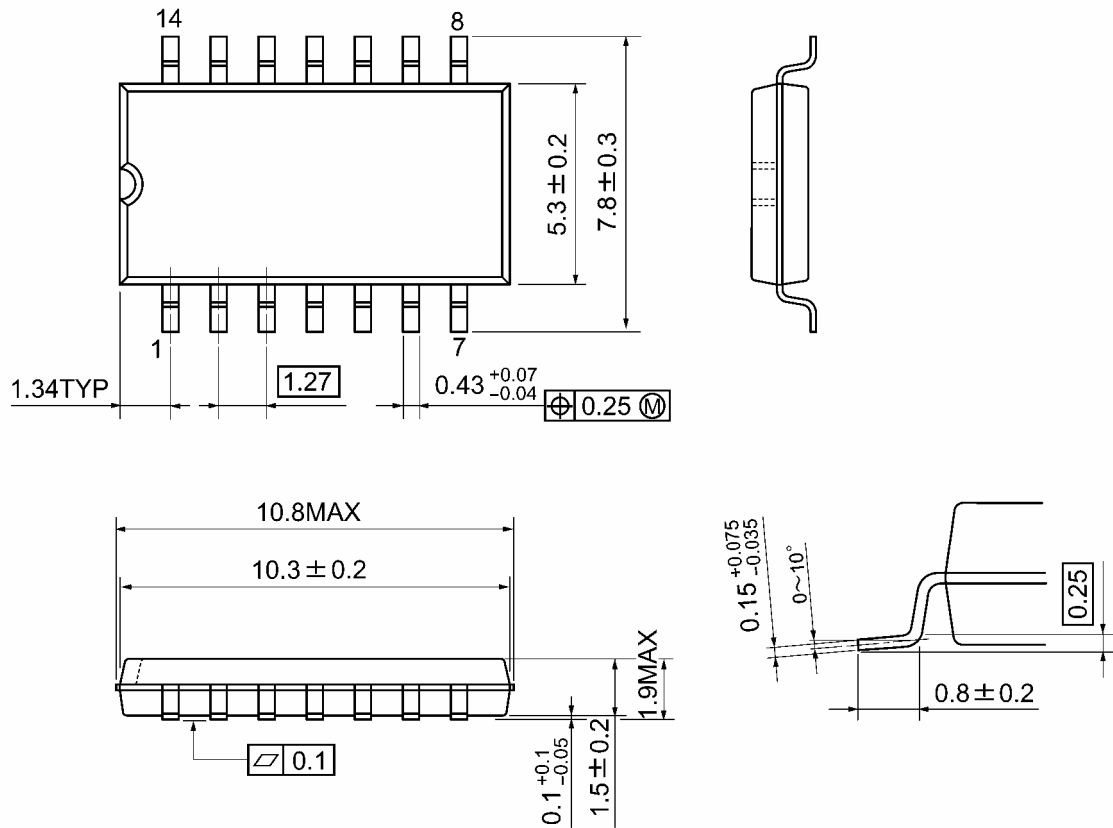

Weight: 0.18 g (typ.)

Package Dimensions (Note)

SOL14-P-150-1.27

Unit : mm

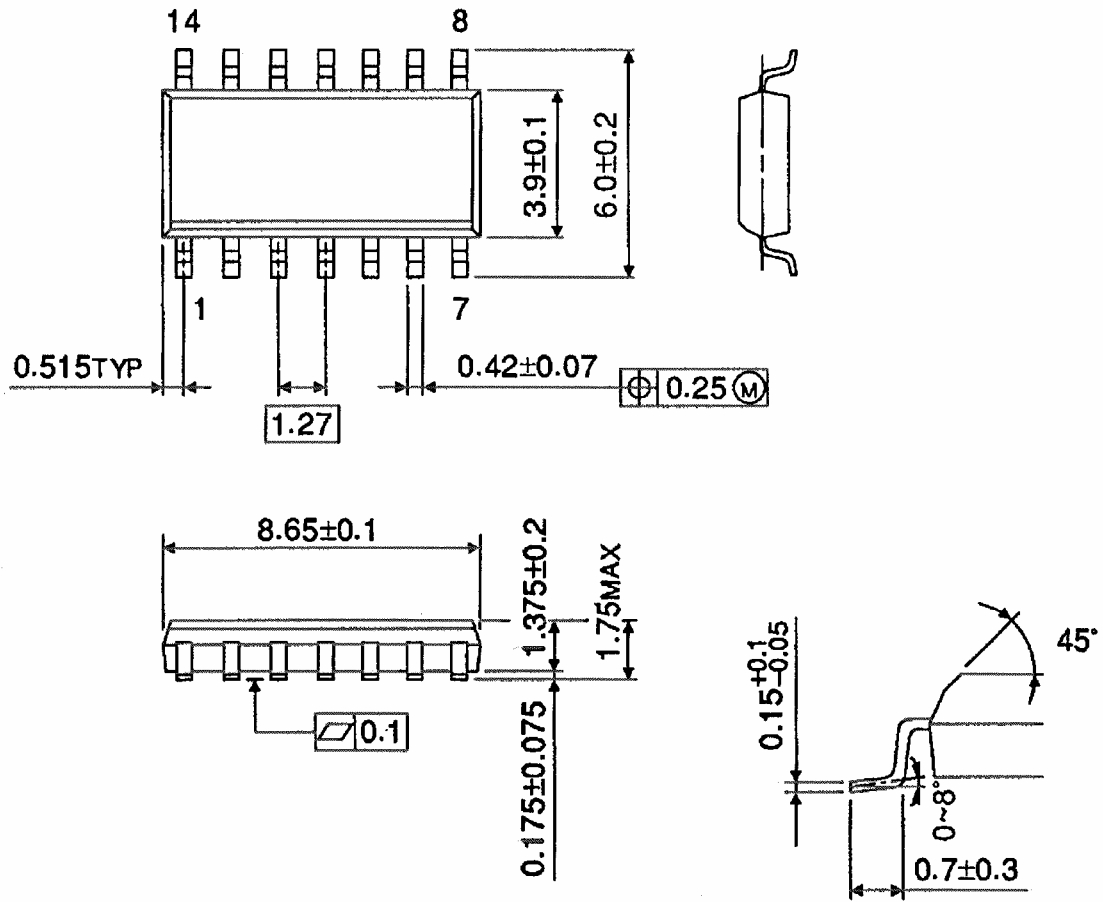

Note: This package is not available in Japan.

Weight: 0.12 g (typ.)

RESTRICTIONS ON PRODUCT USE

20070701-EN GENERAL

- The information contained herein is subject to change without notice.
- TOSHIBA is continually working to improve the quality and reliability of its products. Nevertheless, semiconductor devices in general can malfunction or fail due to their inherent electrical sensitivity and vulnerability to physical stress. It is the responsibility of the buyer, when utilizing TOSHIBA products, to comply with the standards of safety in making a safe design for the entire system, and to avoid situations in which a malfunction or failure of such TOSHIBA products could cause loss of human life, bodily injury or damage to property.
In developing your designs, please ensure that TOSHIBA products are used within specified operating ranges as set forth in the most recent TOSHIBA products specifications. Also, please keep in mind the precautions and conditions set forth in the "Handling Guide for Semiconductor Devices," or "TOSHIBA Semiconductor Reliability Handbook" etc.
- The TOSHIBA products listed in this document are intended for usage in general electronics applications (computer, personal equipment, office equipment, measuring equipment, industrial robotics, domestic appliances, etc.). These TOSHIBA products are neither intended nor warranted for usage in equipment that requires extraordinarily high quality and/or reliability or a malfunction or failure of which may cause loss of human life or bodily injury ("Unintended Usage"). Unintended Usage include atomic energy control instruments, airplane or spaceship instruments, transportation instruments, traffic signal instruments, combustion control instruments, medical instruments, all types of safety devices, etc.. Unintended Usage of TOSHIBA products listed in this document shall be made at the customer's own risk.
- The products described in this document shall not be used or embedded to any downstream products of which manufacture, use and/or sale are prohibited under any applicable laws and regulations.
- The information contained herein is presented only as a guide for the applications of our products. No responsibility is assumed by TOSHIBA for any infringements of patents or other rights of the third parties which may result from its use. No license is granted by implication or otherwise under any patents or other rights of TOSHIBA or the third parties.
- Please contact your sales representative for product-by-product details in this document regarding RoHS compatibility. Please use these products in this document in compliance with all applicable laws and regulations that regulate the inclusion or use of controlled substances. Toshiba assumes no liability for damage or losses occurring as a result of noncompliance with applicable laws and regulations.