

5.2 – 5.9 GHz 2W Single Bias MMIC

FEATURES

- P₁ dB: 33 dBm
- Small Signal Gain: 20 dB
- Power Added Efficiency: 25 %
- IP3: 42 dBm
- Input/Output 50 Ω Match
- Bias condition: 1000 mA @ 9 V

PHOTO ENLARGEMENT



DESCRIPTION

The TC3541 is a 2-stage PHEMT Single Bias MMIC power amplifier. It is designed for use in low cost and high volume 5.2~5.9 GHz band applications. The MMIC is matched to 50Ω operation. It provides a typical gain of 20 dB and P1dB power of 33 dBm. Typical bias condition is 9V at 1000 mA. The MMIC is packaged in a copper based ceramic 10 pins power package. The copper based carrier of the package allows direct soldering of the device to the PCB.

APPLICATIONS

- **Wi-Fi**
- **Wi Max**
- **Radio Link**

ELECTRICAL SPECIFICATIONS (T_A=25 °C)

Symbol	Conditions	MIN	TYP	MAX	UNIT
FREQ	Frequency Range	5.2		5.9	GHz
SSG	Small Signal Gain	19	20		dB
GOF	Small Signal Gain Flatness		±0.5		
P₁ dB	Output Power at 1 dB Gain Compression	31.5	33		dBm
IP3	Third Order Intercept Point	40	42		dBm
VDD	Supply Voltage		9		Volt
IDD	Current Supply Without RF		1000		mA
η_a	Power Added Efficiency		25		%

Absolute Maximum Ratings

Symbol	Parameter/Conditions	Min.	Max.	Units
V _{dd}	Drain-Source Voltage		10	Volts
P _{in}	RF Input Power		17	dBm
P _t	Power Dissipation		11.6	W
T _{ch}	Operating Channel Temperature		175	°C
T _{STG}	Storage Temperature	-65	175	°C

Note:

1. This GaAs MMIC is susceptible to damage from Electrostatic Discharge. Proper precautions should be used when handling these devices.
2. Specifications subject to change without notice.

EVALUATION BOARD

PCB Material: RO4003

ER = 3.38

Thickness = 20 mil

Unit: mil

- * DXF file of the PCB can be downloaded from our web-site at www.transcominc.com.tw

- * Application Notes:

For better heat sinking and grounding, it's recommended to have the via holes beneath TC3541 filled with solder and have two screws installed on required heat sink plate besides TC3541 on the PCB area.

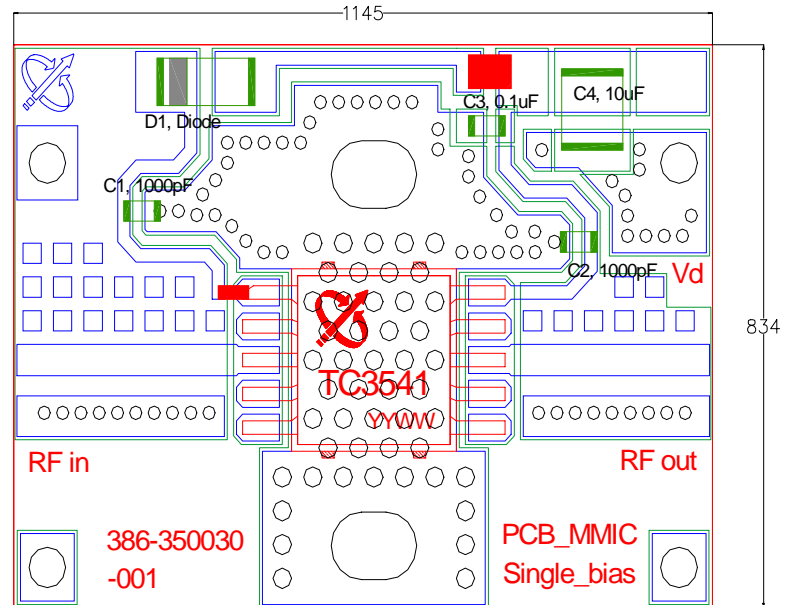
Evaluation Board Parts List

Qty	Part Type	Reference Designator	Description	Manufacturer	Part Number
2	Capacitor	C1, C2	Chip CAP (0603) 1000PF±10%	Murata	GRM39X7R102K50V
1	Capacitor	C3	Chip CAP (0603) 0.1µF±20%	Murata	GRM39Y5V104Z25V
1	Capacitor	C4	Chip CAP (1210) 10µF±20% or Chip CAP (1206) 10µF±20%	Murata	GRM42-6Y5V106Z25V or GRM31CF5E106ZA01L
1	Diode	D1	Diode, 400V, 1A (SOD-123)		SM4005M