

TB6549F/FG, TB6549P/PG, TB6549HQ

Full-Bridge Driver IC for DC Motors

The TB6549F/FG/P/PG/HQ is a full-bridge driver IC for DC motors that uses an LDMOS structure for output transistors. High-efficiency drive is possible through the use of a MOS process with low ON-resistance and a PWM drive system. Four modes, CW, CCW, short brake, and stop, can be selected using IN1 and IN2.

Features

- Power supply voltage: 30 V (max)
- Output current: 3.5 A (max) (F/FG,P/PG type) / 4.5 A (max.) (HQ type)
- Low ON-resistance: 0.5 Ω (typ.)
- PWM control capability
- Standby system
- Function modes: CW/CCW/short brake/stop
- Built-in overcurrent protection
- Built-in thermal shutdown circuit
- Package: HSOP-20/DIP-16

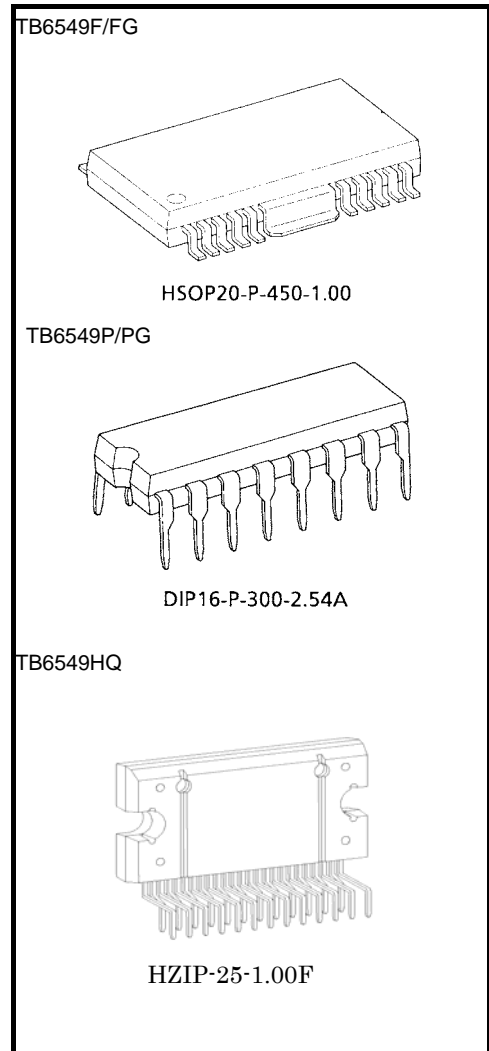

TB6549FG/PG/HQ:
 The TB6549FG/PG is a Pb-free product.
 The TB6549HQ is a Sn-Ag plated product including Pb.
 The following conditions apply to solderability:
 *Solderability

1. Use of Sn-37Pb solder bath
 - *solder bath temperature = 230°C
 - *dipping time = 5 seconds
 - *number of times = once
 - *use of R-type flux
2. Use of Sn-3.0Ag-0.5Cu solder bath
 - *solder bath temperature = 245°C
 - *dipping time = 5 seconds
 - *number of times = once
 - *use of R-type flux

Weight
 HSOP20-P-450-1.00: 0.79 g (typ.)
 DIP16-P-300-2.54A: 1.11 g (typ.)
 HZIP-25-1.00F: 7.7g (typ.)

Pin Assignment

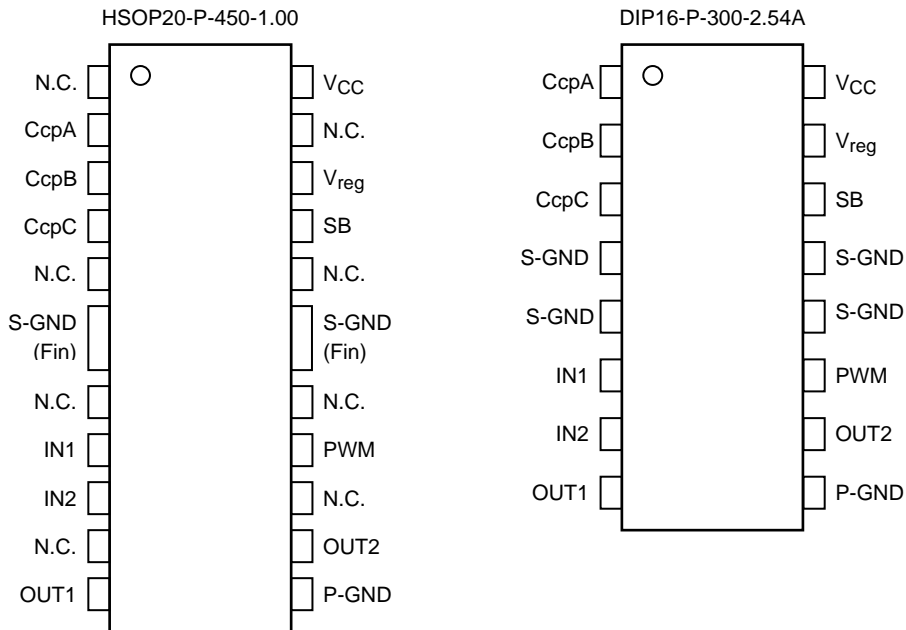

Note: This product has a MOS structure and is sensitive to electrostatic discharge. When handling this product, ensure that the environment is protected against electrostatic discharge by using an earth strap, a conductive mat and an ionizer. Ensure also that the ambient temperature and relative humidity are maintained at reasonable levels.

Block Diagram

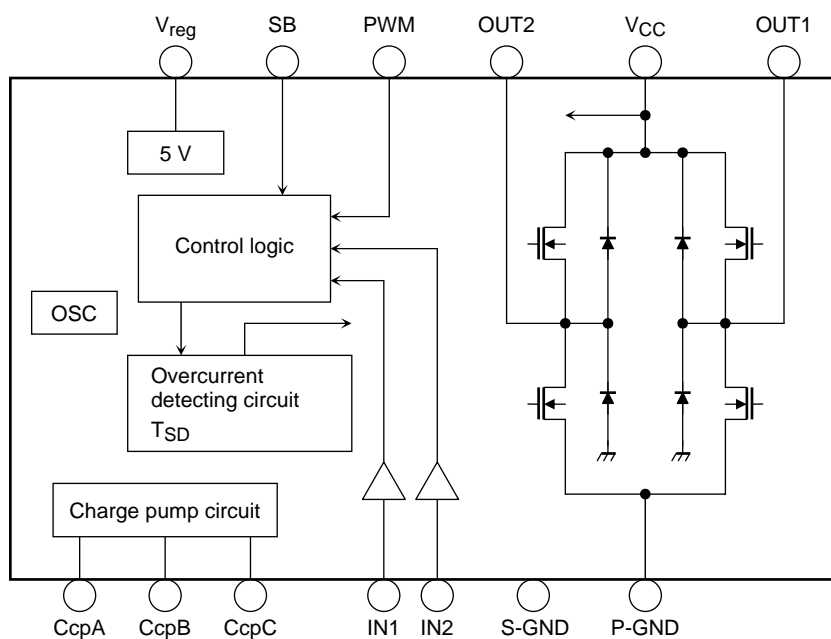

Pin Functions

Pin No.			Pin Name	Functional Description	Remarks
F/FG	P/PG	HQ			
1	—	—	(NC)	No Connection	—
2	1	14	CcpA	Capacitor connection pin for charge pump A	Connect a capacitor for charge pump
3	2	15	CcpB	Capacitor connection pin for charge pump B	Connect a capacitor for charge pump
4	3	16	CcpC	Capacitor connection pin for charge pump C	Connect a capacitor for charge pump
5	—	—	(NC)	No Connection	—
6	—	—	(NC)	No Connection	—
7	6	23	IN1	Control signal input 1	Input 0/5-V signal
8	7	24	IN2	Control signal input 2	Input 0/5-V signal
9	—	—	(NC)	No Connection	—
10	8	25	OUT1	Output pin 1	Connect to motor coil pin
11	9	1	P-GND	Power GND	—
12	10	2,5	OUT2	Output pin 2	Connect to motor coil pin
13	—	—	(NC)	No Connection	—
14	11	3	PWM	PWM control signal input pin	Input 0/5-V PWM signal
15	—	—	(NC)	No Connection	—
16	—	—	(NC)	No Connection	—
17	14	10	SB	Standby pin	H: Start, L: Standby
18	15	11	V _{reg}	5 V output pin	Connect a capacitor to S-GND
19	—	—	(NC)	No Connection	—
20	16	12	V _{CC}	Power supply input pin	V _{CC (ope)} = 10 to 27 V
FIN	4, 5, 12, 13	7, 16	S-GND	GND pin	—

*) (HQ type) 4, 6, 8, 9, 13, 17, 18, 20, 21, 22 ;N.C.

Absolute Maximum Ratings (Ta = 25°C)

Characteristic		Symbol	Rating	Unit
Supply voltage		V _{CC}	30	V
Output current	I _O (P, P)	F, P	3.5 (Note1)	A
		HQ	4.5 (Note2)	
	I _O (DC)	F, P	2.0	
		HQ	3.5	
Input voltage		V _{in}	-0.3 ~ 5.5	V
Power dissipation	F/FG	P _D	2.5 (Note3)	W
	P/PG		2.7 (Note4)	
	HQ		3.2 (Note5)	
			40 (Note6)	
Operating temperature		T _{opr}	-20~85	°C
Storage temperature		T _{stg}	-55~150	°C

Note1: The absolute maximum ratings must be observed strictly. Make sure that no characteristic listed above ever exceeds the absolute maximum rating.

Note2: t=100ms

Note3: This value is obtained for a 115 × 75 × 1.6 mm PCB mounting with 30% copper area.

Note4: This value is obtained for a 50 × 50 × 1.6 mm PCB mounting with 50% copper area.

Note5: IC only.

Note6: Infinite heat sink.

Operating Range (Ta = 25°C)

Characteristic	Symbol	Rating	Unit
Supply voltage	V _{CC}	10 to 27	V
PWM frequency	f _{CLK}	100	kHz

Electrical Characteristics (V_{CC} = 24 V, Ta = 25°C)

Characteristic		Symbol	Test Circuit	Test Condition	Min	Typ.	Max	Unit	
Supply current		I _{CC1}	1	Stop mode	—	4	8	mA	
		I _{CC2}		CW/CCW mode	—	6	10		
		I _{CC3}		Short break mode	—	4	8		
		I _{CC4}		(Standby mode)	—	1	2		
Control circuit		V _{INH}	2		2	—	5.5	V	
		V _{INL}			—	—	0.8		
		Hysteresis voltage	V _{IN (HYS)}	—	(Not tested)	—	0.2	—	μA
		Input current	I _{INH}	1	V _{IN} = 5 V	—	50	75	
	I _{INL}	V _{IN} = 0 V	—		—	5			
PWM input circuit		V _{PWMH}	3		2	—	5.5	V	
		V _{PWML}			—	—	0.8		
		Hysteresis voltage	V _{PWM(HYS)}	—	(Not tested)	—	0.2	—	μA
		Input current	I _{PWMH}	3	V _{PWM} = 5 V	—	50	75	
			I _{PWML}		V _{PWM} = 0 V	—	—	5	
	PWM frequency	f _{PWM}	3	Duty = 50%	—	—	100	kHz	
	Minimum clock pulse width	tw(PWM)			2	—	—	μs	
Standby circuit		V _{INSH}	2		2	—	5.5	V	
		V _{INSL}			—	—	0.8		
		Hysteresis voltage	V _{IN (HYS)}	—	(Not tested)	—	0.2	—	μA
		Input current	I _{INSH}	1	V _{IN} = 5 V	—	50	75	
	I _{INSL}	V _{IN} = 0 V	—		—	5			
Output ON-resistance		R _{ON (U + L)}	4		—	1.0	1.75	Ω	
				I _o = 1.5 A	—	1.0	1.75		
Output leakage current		I _{L (U)}	5	V _{CC} = 30 V (Note 1)	—	—	150	μA	
		I _{L (L)}		V _{CC} = 30 V	—	—	10		
Diode forward voltage		V _{F (U)}	6	I _o = 1.5 A		1.3	1.7	V	
		V _{F (L)}		I _o = 1.5 A		1.3	1.7		
Internal reference voltage		V _{reg}	4	No load	4.5	5	5.5	V	
Overcurrent detection offset time		I _{SD (OFF)}	—	(Not tested)	—	50	—	μs	
Charge pump rising time		t _{ONG}	7	C ₁ = 0.22 μF, C ₂ = 0.01 μF (Note 2)	—	1	3	ms	
Thermal shutdown circuit operating temperature		T _{SD}	—	(Not tested)	—	160	—	°C	

Note 1: Include the current in the circuit.

Note 2: C₁ is a capacitor between CcpA and GND. C₂ is a capacitor between CcpB and CcpC.

Component Description

1. Control Input/PWM Input Circuit

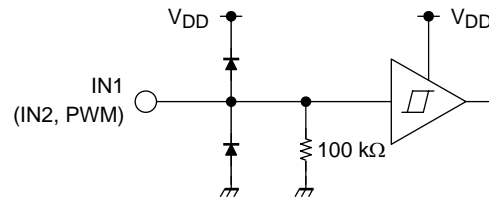

- The input signals are shown below. Input at the CMOS and TTL levels can be provided. Note that the input signals have a hysteresis of 0.2 V (typ.).
 V_{INH} : 2 to V_{reg} V
 V_{INL} : GND to 0.8 V
- The PWM input frequency should be 100 kHz or less.

Input/Output Function

Input				Output		
IN1	IN2	SB	PWM	OUT1	OUT2	Mode
H	H	H	H ----- L	L	L	Short brake
L	H	H	H	L	H	CW/CCW
			L	L	L	Short brake
H	L	H	H	H	L	CCW/CW
			L	L	L	Short brake
L	L	H	H	OFF (high impedance)		Stop
			L	OFF (high impedance)		
H/L	H/L	L	H	OFF (high impedance)		Standby
			L	OFF (high impedance)		

- PWM control function**
 Motor speed can be controlled by inputting the 0/5-V PWM signal to the PWM pin.
 When PWM control is provided, normal operation and short brake operation are repeated.
 If the upper and lower power transistors in the output circuit were ON at the same time, a penetrating current would be produced. To prevent this current from being produced, a dead time of 300 ns (design target value) is provided in the IC when either of the transistors changes from ON to OFF, or vice versa. Therefore, PWM control by synchronous rectification is enabled without an OFF time being inserted by external input. Note that a dead time is also provided in the IC at the time of transition between CW and CCW or between CW (CCW) and short brake mode, thereby eliminating the need for an OFF time.

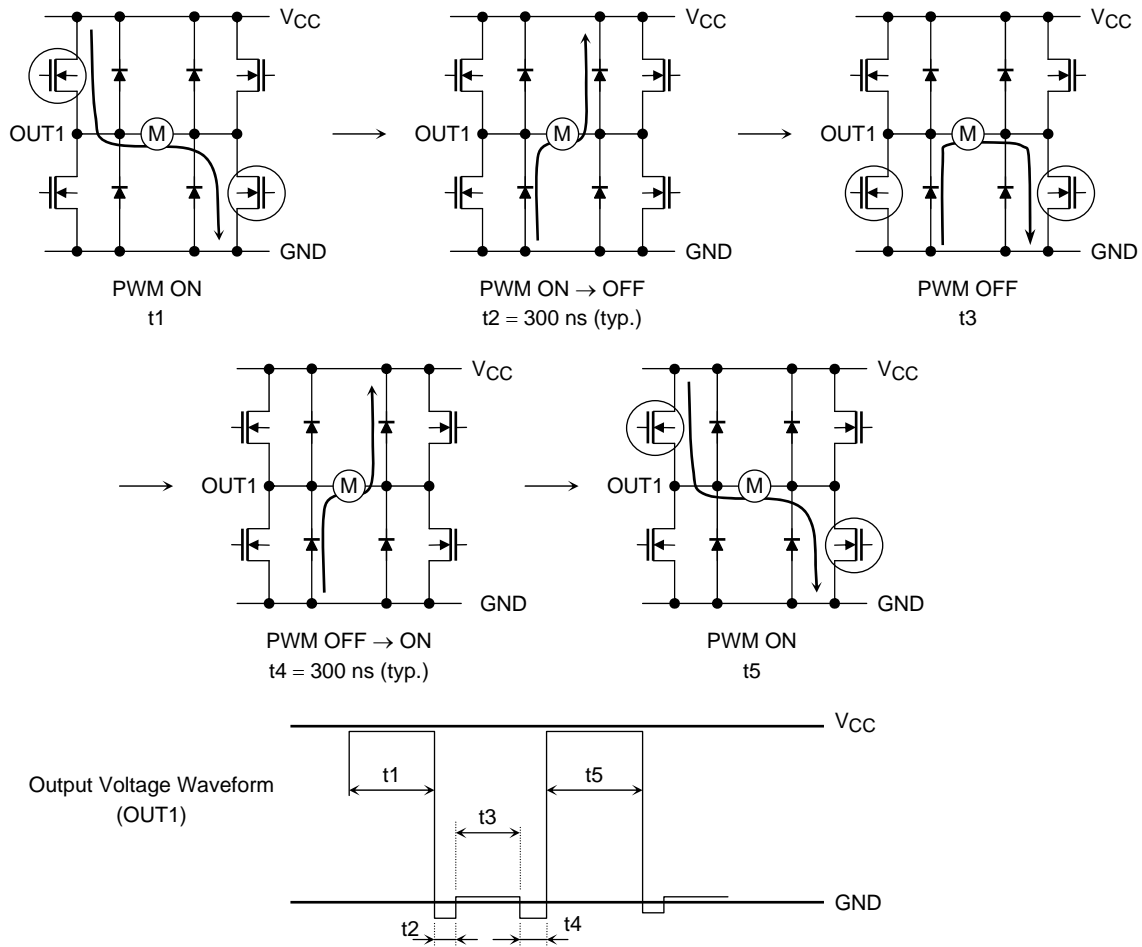

Note: Be sure to set the pin PWM to High when the PWM control function is not used.

2. Standby Circuit

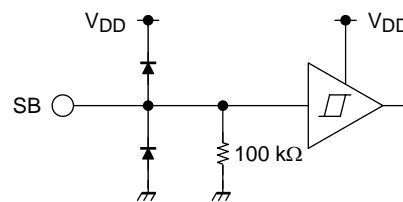

- All circuits are turned off except the standby circuit and the charge pump circuit under the standby condition.
- The input voltage range is shown below. Input at CMOS and TTL level is possible. The input signal has 0.2 V (typ.) hysteresis.
 V_{INSH} : 2 to V_{reg} V
 V_{INSL} : GND to 0.8 V
- Do not attempt to control the output by inputting PWM signals to the standby pin. Doing so may cause the output signal to become unstable, resulting in destruction of the IC.
- The charge pump circuit is turned ON/OFF by the switch of the input signal from the standby pin. If the switching cycle is shorter than 50 ms, the charge pump circuit will not operate with precise timing. Therefore the switching cycle of the standby pin should be longer than 50 ms.
- When the Standby condition is changed to Operation Mode, set IN1 and IN2 to Low level (Stop Mode) at first. Then switch IN1 and IN2 to High level when the charge pump circuit reaches the stable condition, i.e., when V_{cpA} is about $V_{CC} + 5 \text{ V}$.

3. Internal Constant-Voltage (5 V) Circuit

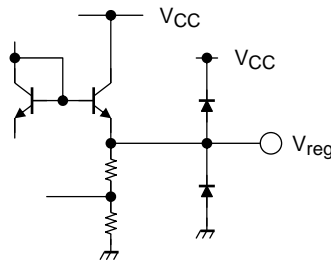

- This IC includes a 5 V power supply for control circuit.
- A capacitor for prevention of oscillation should be connected to S-GND associated with the pin Vreg. No other loads should be connected to pin Vreg.
- This IC has a power monitoring function and turns the output OFF when Vreg goes down to 3.0 V (design target value) or less. With a hysteresis of 0.3 V (design target value), the output are turned ON when Vreg again reaches 3.3 V (design target value).

4. Charge Pump Circuit

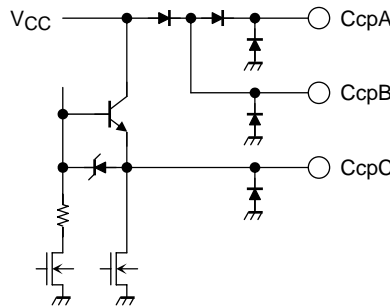

- This IC has a charge pump circuit for driving the gate for the upper power transistor in the output circuit. A voltage of $V_{CC} + 5\text{ V}$ (typ.) is generated by connecting an external capacitor to this IC. It takes about 2 ms to boost VCPA up $V_{CC} + 5\text{ V}$ (typ.) after the switching of the input signal from the standby pin (while CcpA = 0.22 μF , and CcpB and CcpC are connected through 0.01 μF).
- The proper capacitance of the external capacitor varies depending on the VCC value. Thus, determine the constant by referring to the following data. The value of the capacitor between CcpB and CcpC should be such that, while the motor is being driven, the voltage on the CcpA pin will be kept constant, typically at $V_{CC} + 5\text{ V}$. (If a reduced VCC level causes the voltage on CcpA to start to fall, please adjust this capacitance value accordingly.)

<External capacitor>

VCC	Between CcpB and CcpC	Between CcpA and GND
10 V~15 V	0.01 μF ~0.047 μF	0.22 μF
15 V~27 V	0.01 μF	0.22 μF

- Reference oscillation is performed by using the internal capacitor.

5. Output Circuit

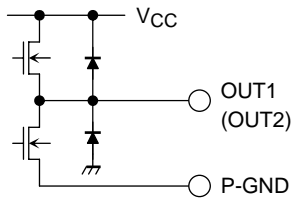

- This IC uses Nch MOS transistors as the upper and lower transistors in the output circuit.
- As output R_{on} is $1\ \Omega$ (sum for the upper and lower parts/typ.), this IC is a device of the low- R_{on} type.
- The switching characteristics of the output transistors are shown below.

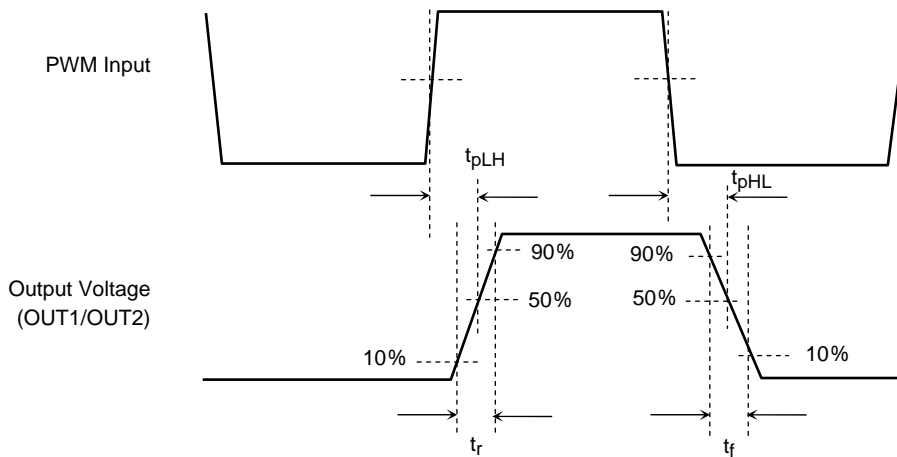

<Typical Value>

Item	Typical Value	Unit
t_{pLH}	350	ns
t_{pHL}	800	
t_r	60	
t_f	100	

<Actual Measured Waveform>

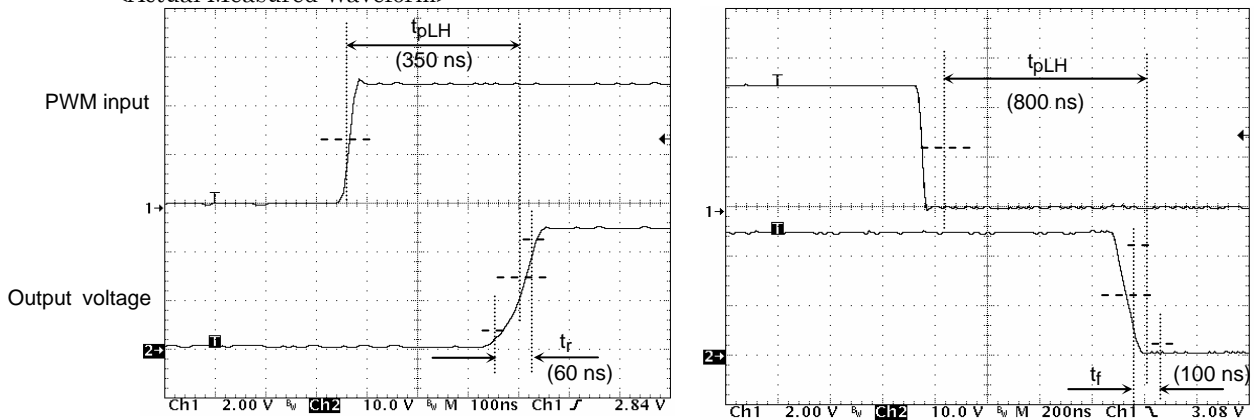

*: OUT 1, OUT 2; open

6. VCC Power Supply Section

- The VCC power supply delivers a voltage to the output circuit, charge pump circuit, and internal 5 V circuit.
- The operating voltage range is shown below:
 $V_{CC (opr.)} = 10 \text{ to } 27 \text{ V}$
- This IC has a power monitoring function for preventing an output malfunction on power-up. However, Toshiba recommends that IN1, IN2, and SB be set to the Low level at power-on.

7. GND Sections

- This IC includes two separate GND sections: S-GND for controlling and P-GND for outputting. Be sure to short-circuit these two GNDs as close to TB6549 as possible.

8. Power Monitoring Circuit

- This circuit turns the output OFF when V_{reg} becomes 3.0 V (design target value) or less. At this time, $V_{CC} = 4.6 \text{ V (typ.)}$.
- With a hysteresis of 0.3 V (design target value), the output turns back ON when V_{reg} exceeds 3.3 V (design target value) after this circuit starts operating.

9. Thermal Shutdown (TSD) Circuit

This IC includes a thermal shutdown circuit, which turns the output OFF when the junction temperature (T_j) exceeds 160°C (typ.). The output turns back ON automatically. The thermal hysteresis is 20°C.

$$T_{SD} = 160^\circ\text{C (design target value)}$$

$$\Delta T_{SD} = 20^\circ\text{C (design target value)}$$

10. Overcurrent Detection (I_{SD}) Circuit

This IC includes a circuit to detect current flowing through the output power transistors. The current limit is set to 5 A (typ.). The circuit detects a current flowing through each of the four output power transistors. If the current in any one output power transistor exceeds the set limit, this circuit turns all the outputs OFF.

This circuit includes a timer that causes the outputs to be OFF for 50 μs (typ.) after detection of an overcurrent and then turn back ON automatically. If the overcurrent continues to flow, this ON-OFF operation is repeated. Note that to prevent a malfunction due to a glitch, an insensitive period of 10 μs (typ.) is provided.

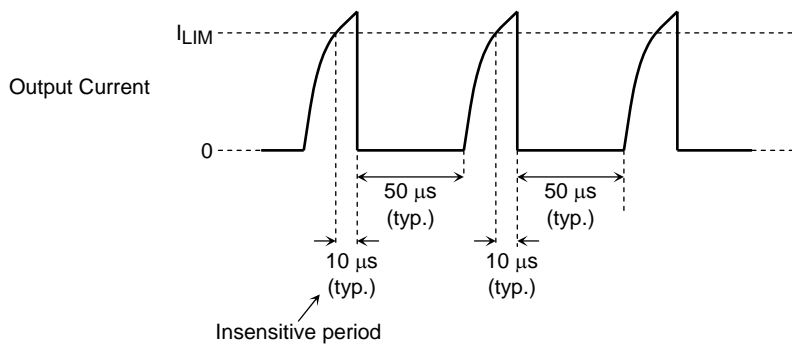

The set limit is 5 A (typ.) as a design target value. The distributions shown below exist because of the variations in thermal characteristics of different ICs. These distributions should be fully considered in the motor torque design.

Also, output peak current should be less than 3 A because of the variations below,

Detected current: Approximately from 3.5 to 6.5 A

Test Circuit

1. I_{cc1} , I_{cc2} , I_{cc3} , I_{cc4} , I_{INH} , I_{INL} , I_{INSH} , I_{INSL}

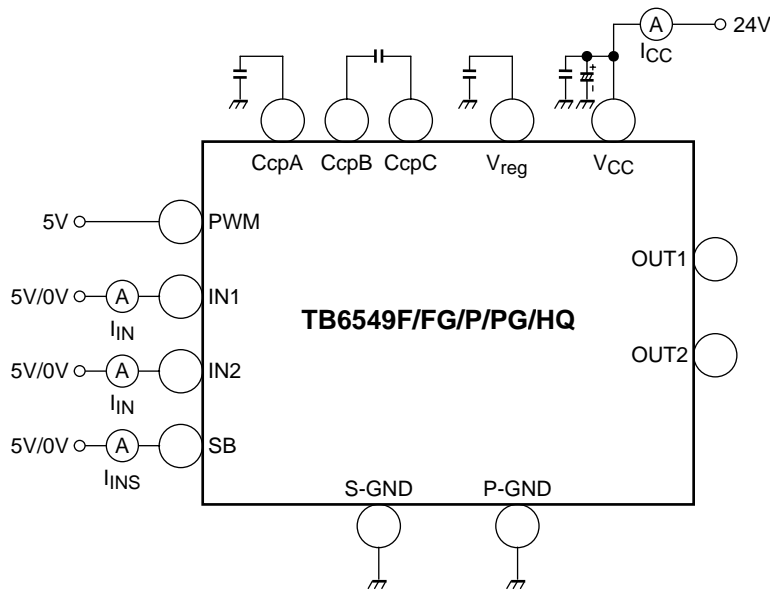

- I_{cc1} : $IN1 = 0\text{ V}$, $IN2 = 0\text{ V}$, $SB = 5\text{ V}$
- I_{cc2} : $IN1 = 5\text{ V}$, $IN2 = 5\text{ V}$, $SB = 5\text{ V}$ or $IN1 = 0\text{ V}$, $IN2 = 5\text{ V}$, $SB = 5\text{ V}$
- I_{cc3} : $IN1 = 5\text{ V}$, $IN2 = 5\text{ V}$, $SB = 5\text{ V}$
- I_{cc4} : $IN1 = 5\text{ V}/0\text{ V}$, $IN2 = 5\text{ V}/0\text{ V}$, $SB = 0\text{ V}$
- I_{INH} : $IN1 = 5\text{ V}$, and $IN2 = 5\text{ V}$
- I_{INL} : $IN2 = 0\text{ V}$, and $IN2 = 0\text{ V}$
- I_{INSH} : $SB = 5\text{ V}$
- I_{INSL} : $SB = 0\text{ V}$

2. V_{INH} , V_{INL} , V_{INSH} , V_{INSL}

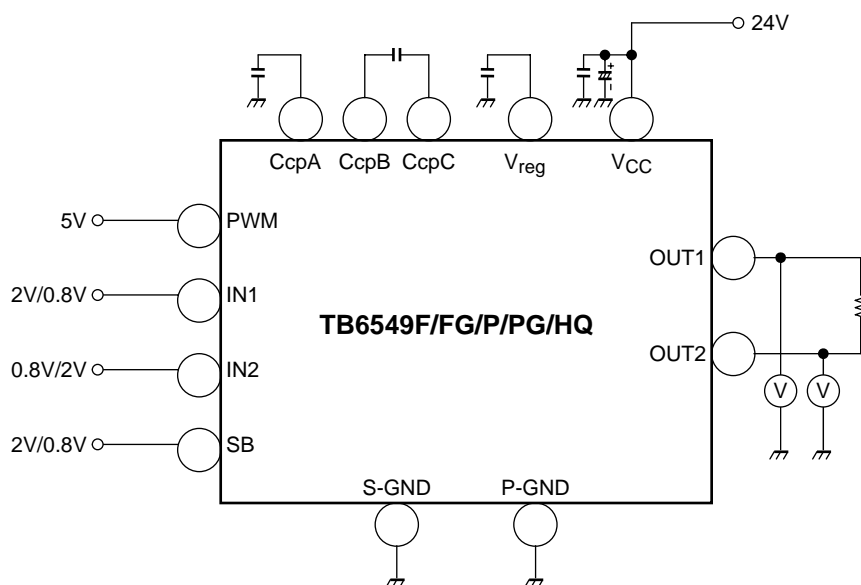

- V_{INH} , V_{INSH} : $IN1 = IN2 = SB = 2\text{ V}$. Verify that $OUT1 = OUT2 = L$.
- V_{INL} : $IN1 = 0.8\text{ V}$, $IN2 = SB = 2\text{ V}$. Verify that $OUT1 = L$, $OUT2 = H$. $IN1 = SB = 2\text{ V}$, $IN2 = 0.8\text{ V}$. Verify that $OUT1 = OUT2 = L$.
- V_{INSL} : $IN1 = IN2 = 2\text{ V}$, $SB = 0.8\text{ V}$. Verify that the output function is high impedance.

3. V_{PWMH} , V_{PWML} , I_{PWMH} , I_{PWML} , f_{PWM} , t_w (PWM)

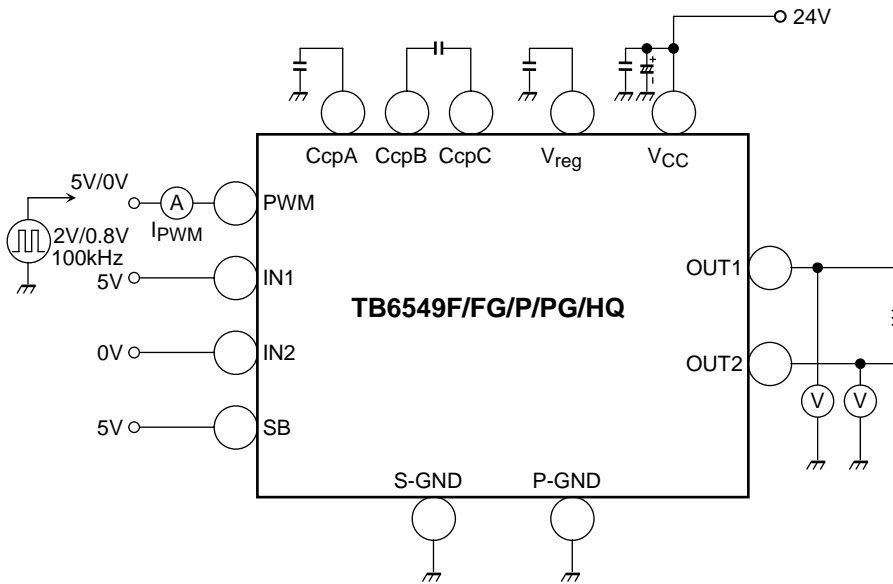

- V_{PWMH} , V_{PWML} , f_{PWM} : PWM = 2 V/0.8 V, 100 kHz; duty: 50 % (rectangular wave). Verify OUT1.
- V_{PWMH} , V_{PWML} : PWM = 5 V or PWM = 0 V.
- t_w (PWM): PWM = 2 V/0.8 V, 100 kHz; duty: 20 % (2 μ s) (2 μ s/rectangular wave). Verify OUT1.

4. R_{on} (H + L), V_{reg}

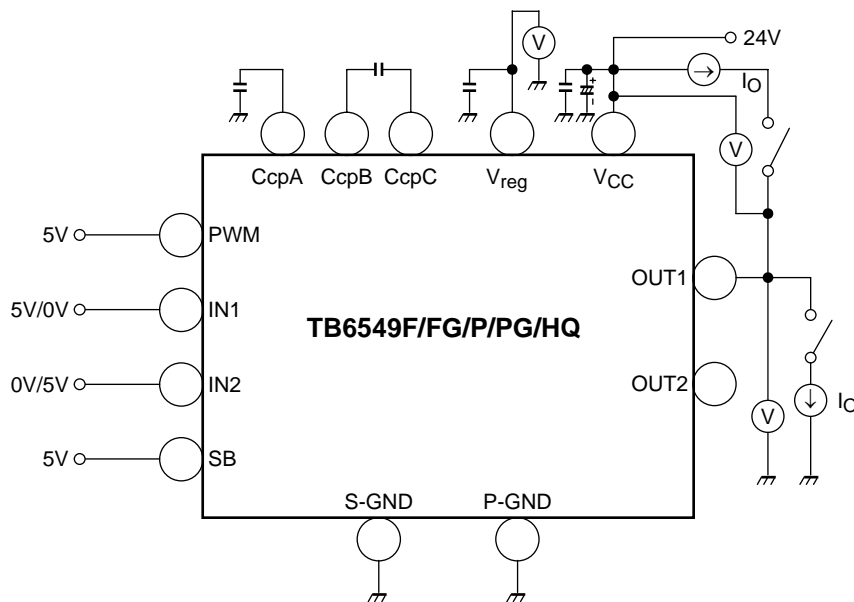

- R_{on} (H + L): Measure V_d s (the sum of upper and lower sides) at $I_o = 0.2$ A, and convert to resistor. Do the same at $I_o = 1.5$ A.
- V_{reg} : V_{reg} pin voltage.

5. $I_L(U)$, $I_L(L)$

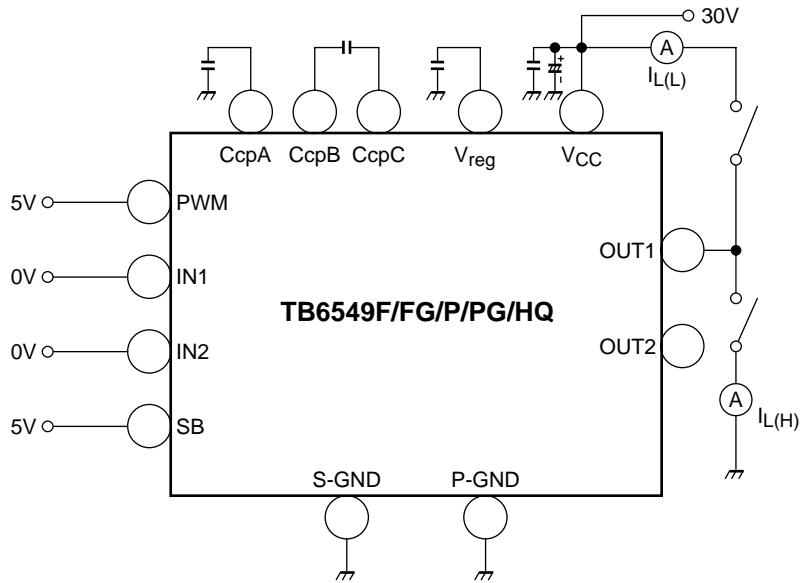

6. $V_F(U)$, $V_F(L)$

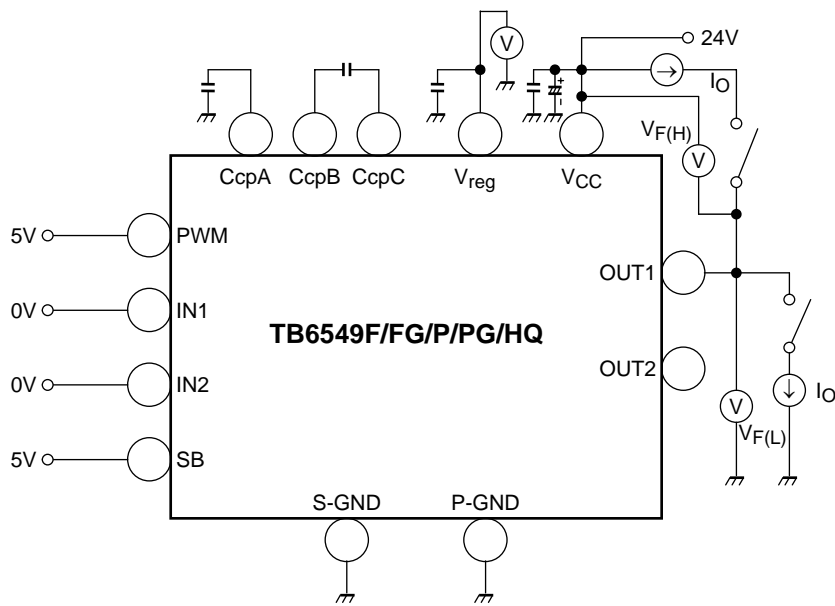

- $V_F(U)$, $V_F(L)$: $I_o = 1.5\text{ A}$.

7. t_{ONG}

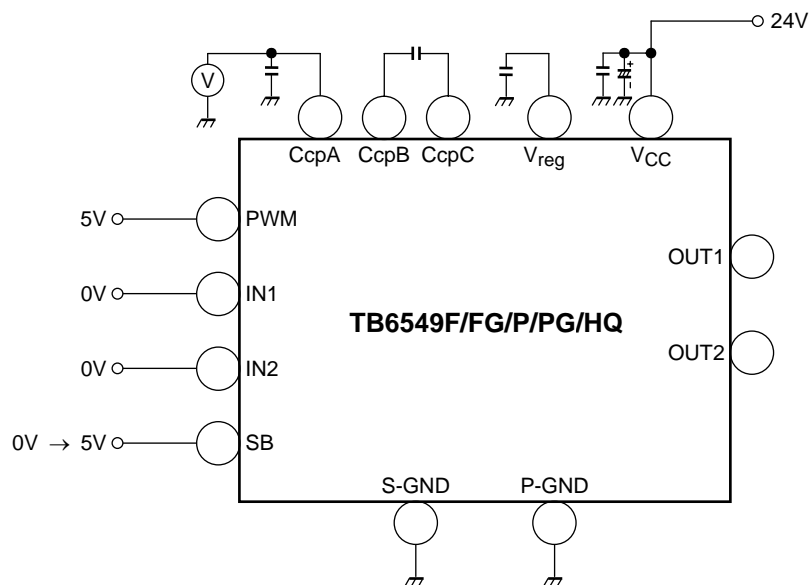

- t_{ONG}: SB = 0 V → 5 V. Measure the time taken to boost the CcpA voltage up to about 29 V (24 V + 5 V).

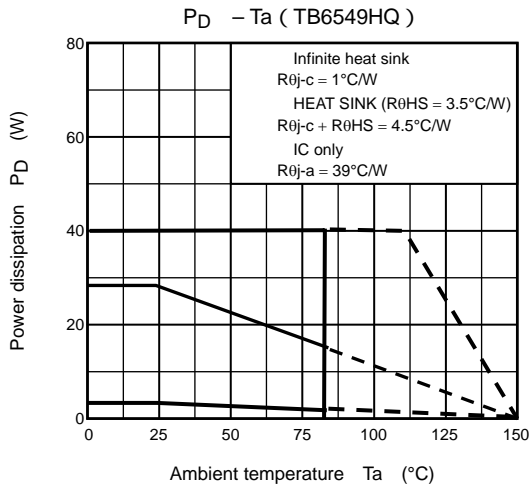
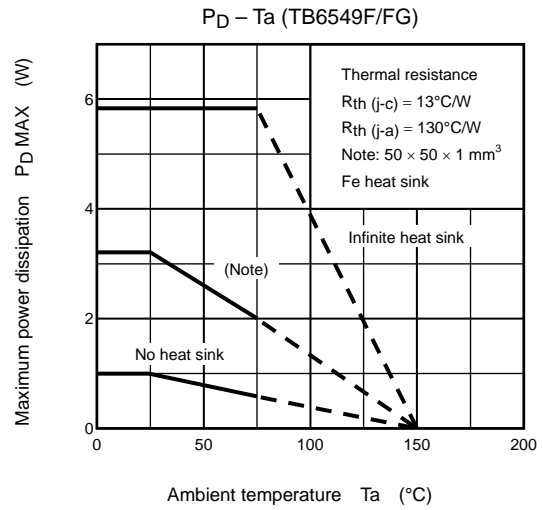
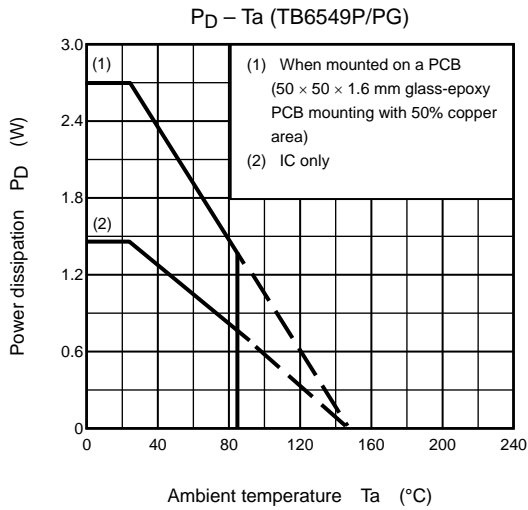

External Attachments

Symbol	Use	Recommended Value	Remarks
C ₁	Charge pump	0.22 μF	—
C ₂	Charge pump	0.01 μF	V _{CC} = 24 V (Note)
		0.033 μF	V _{CC} = 12 V (Note)
C ₃	Prevention of V _{reg} oscillation	0.1 μF to 1.0 μF	—
C ₄	Absorption of power noise	0.001 μF to 1 μF	—
C ₅	Absorption of power noise	50 μF to 100 μF	—

Note: The recommended values for charge pumps depend on the V_{CC} value. Refer to Component Description 4, Charge Pump Circuit.

Typical Application Diagram

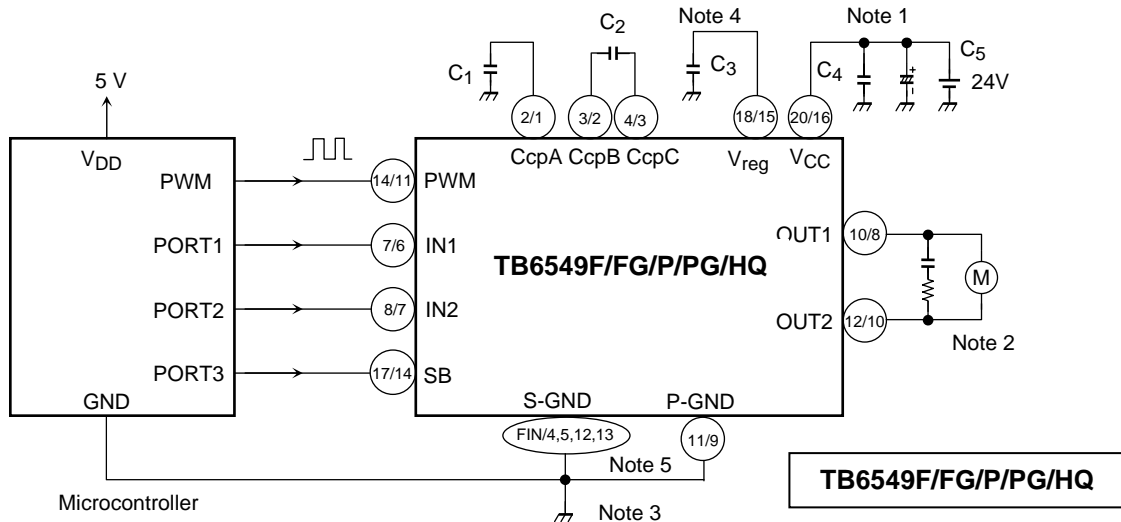

TB6549F/FG: Pins 1, 5, 6, 9, 13, 15, 16, and 19 are not connected.
 TB6549HQ: Pins 4, 6, 8, 9, 13, 17, 18, 20, 21, 22 are not connected.

- Note 1: Connect V_{CC} and P-GND through the power supply capacitor. This capacitor should be as close as possible to the IC.
- Note 2: When connecting the motor pins through the capacitor for reducing noise, connect a resistor to the capacitor for limiting the charge current. The switching loss increases for PWM control. Therefore, whenever practicable, avoid connecting the capacitor if PWM control is required.
- Note 3: Short-circuit S-GND and P-GND as close to the TB6549 as possible.
- Note 4: Connect the capacitor C₃ to S-GND.
- Note 5: Connect the capacitors C₁ and C₂ as close to the TB6549 as possible, and the capacitor C₁ as close to S-GND.
- Note 6: Pins 4, 5, 12, and 13 of the P/PG type are connected to the bed of the chip. Therefore expanding the round area of these pins improves the heat radiation effect.
- Note 7: Pins 2 and 5 of HQ type must be shorted outside.

Usage Precautions

- Utmost care is necessary in the design of the output, V_{CC}, V_M, and GND lines since the IC may be destroyed by short-circuiting between outputs, air contamination faults, or faults due to improper grounding, or by short-circuiting between contiguous pins.
- Be sure to install the IC correctly. The IC may be destroyed if installed wrongly (e.g., in reverse).

Package Dimensions

HSOP20-P-450-1.00

Unit : mm

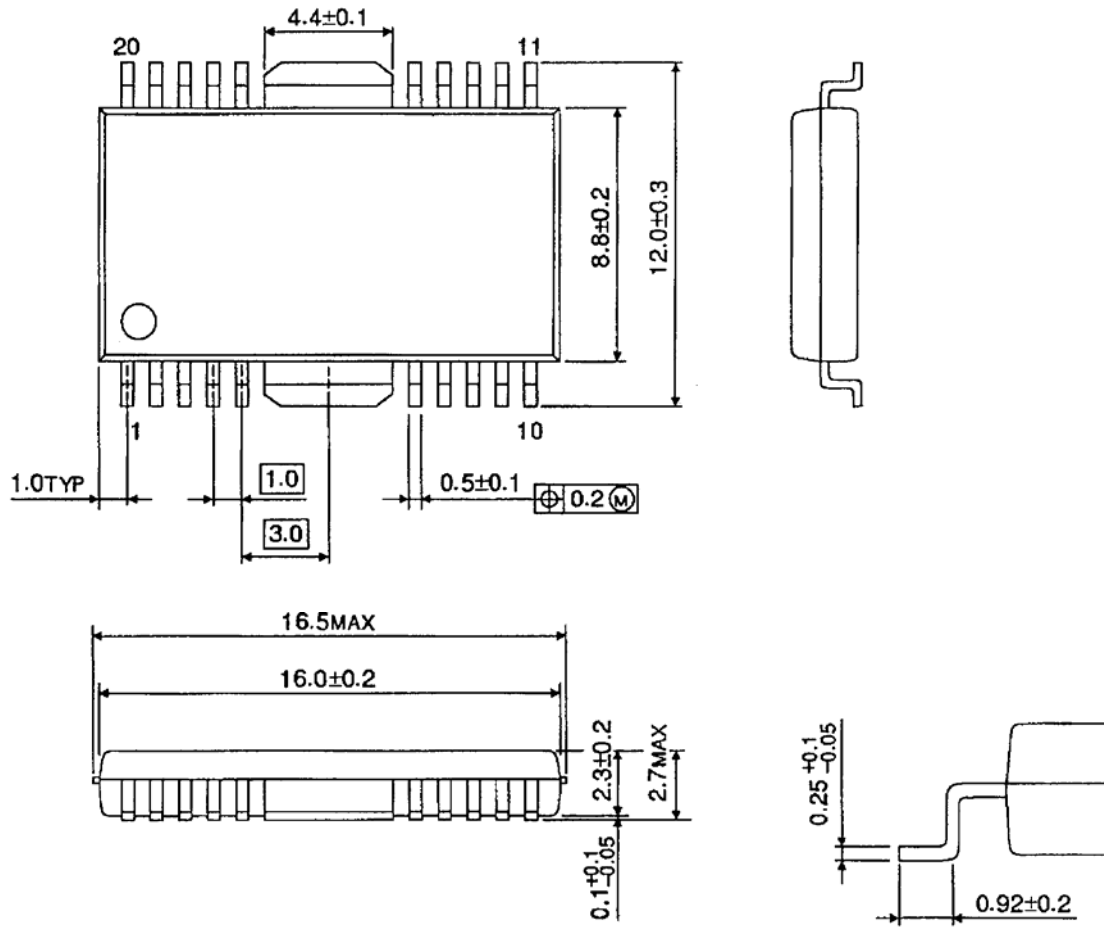

Weight: 0.79 g (typ.)

Package Dimensions

DIP16-P-300-2.54A

Unit : mm

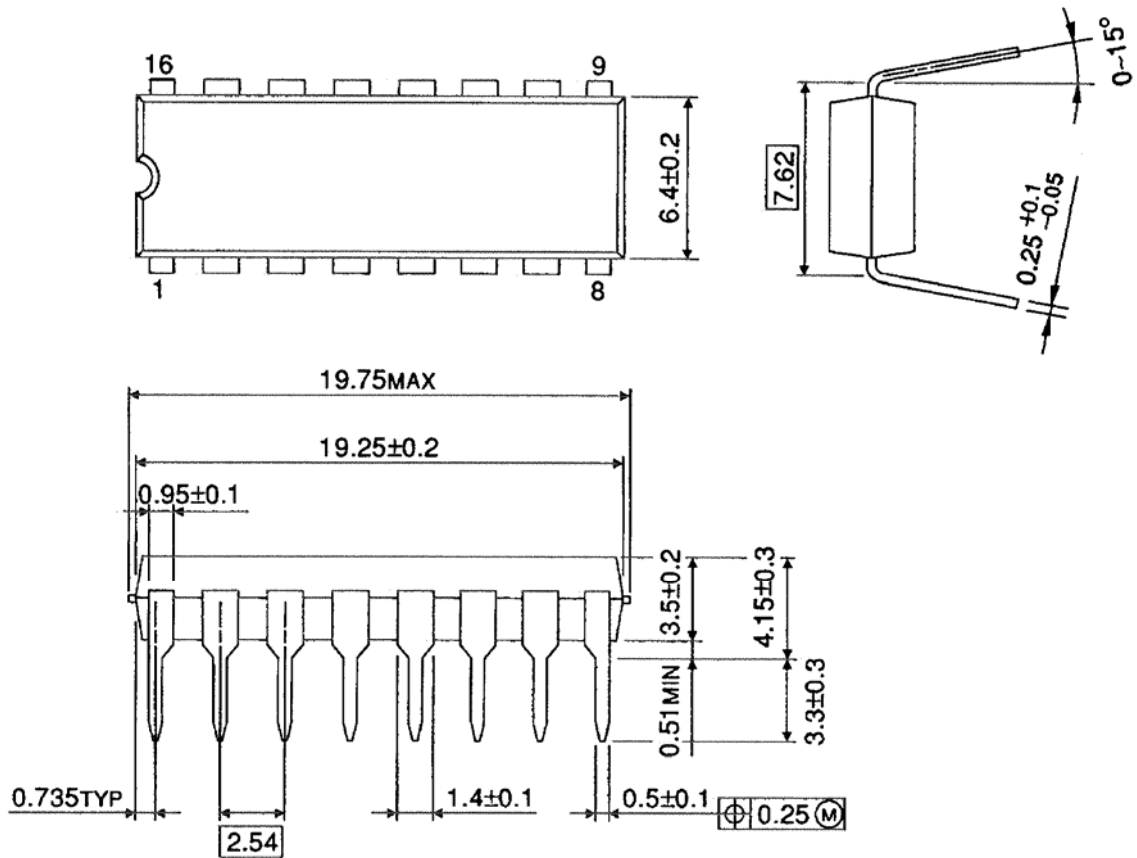

Weight: 1.11 g (typ.)

Package Dimensions

HZIP-25-1.00F

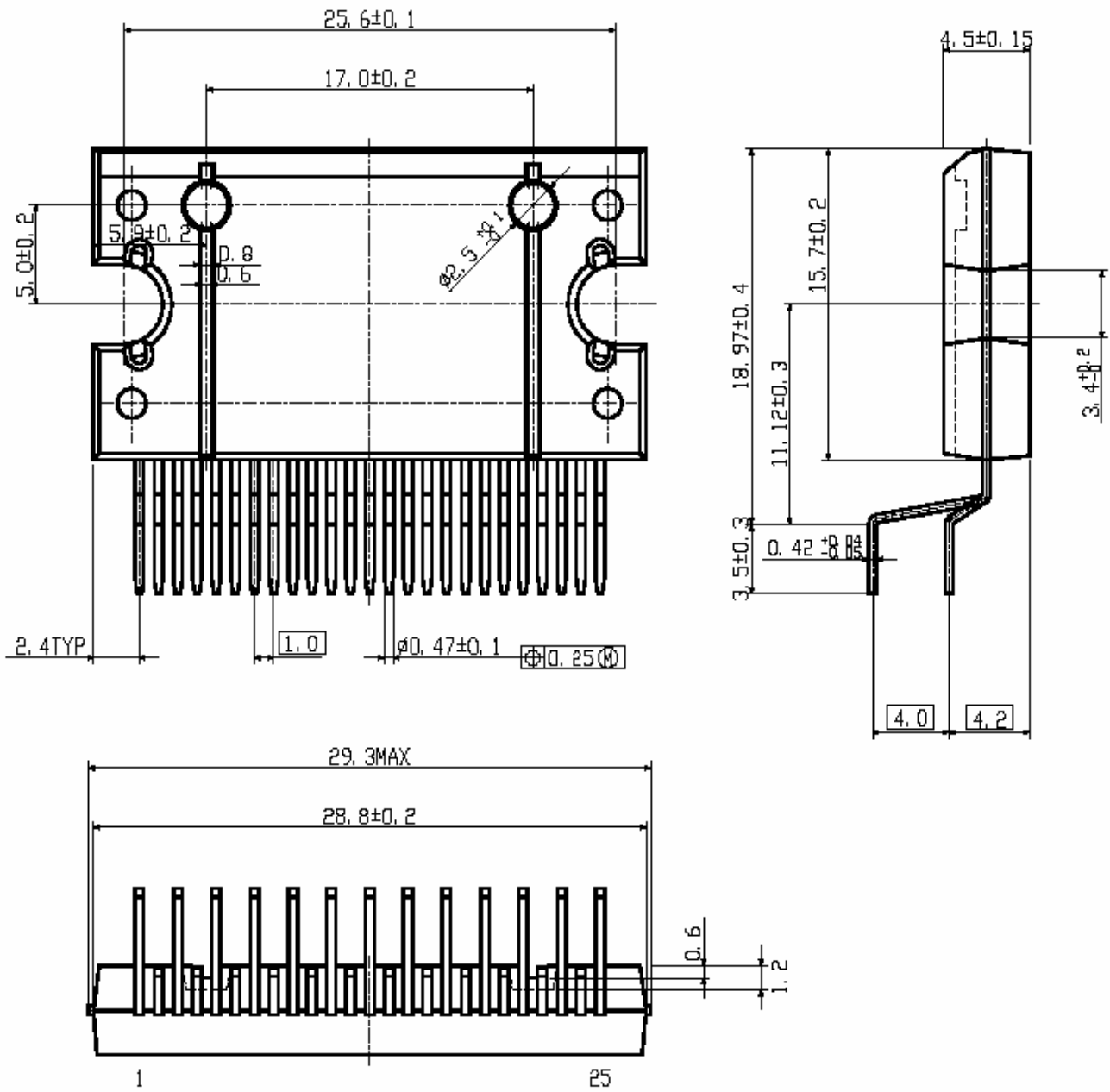

Weight: 7.7 g (typ.)

Notes on Contents

1. Block Diagrams

Some of the functional blocks, circuits, or constants in the block diagram may be omitted or simplified for explanatory purposes.

2. Equivalent Circuits

The equivalent circuit diagrams may be simplified or some parts of them may be omitted for explanatory purposes.

3. Timing Charts

Timing charts may be simplified for explanatory purposes.

4. Application Circuits

The application circuits shown in this document are provided for reference purposes only. Thorough evaluation is required, especially at the mass production design stage.

Toshiba does not grant any license to any industrial property rights by providing these examples of application circuits.

5. Test Circuits

Components in the test circuits are used only to obtain and confirm the device characteristics. These components and circuits are not guaranteed to prevent malfunction or failure from occurring in the application equipment.

IC Usage Considerations

Notes on handling of ICs

- [1] The absolute maximum ratings of a semiconductor device are a set of ratings that must not be exceeded, even for a moment. Do not exceed any of these ratings.
Exceeding the rating(s) may cause the device breakdown, damage or deterioration, and may result injury by explosion or combustion.
- [2] Use an appropriate power supply fuse to ensure that a large current does not continuously flow in case of over current and/or IC failure. The IC will fully break down when used under conditions that exceed its absolute maximum ratings, when the wiring is routed improperly or when an abnormal pulse noise occurs from the wiring or load, causing a large current to continuously flow and the breakdown can lead smoke or ignition. To minimize the effects of the flow of a large current in case of breakdown, appropriate settings, such as fuse capacity, fusing time and insertion circuit location, are required.
- [3] If your design includes an inductive load such as a motor coil, incorporate a protection circuit into the design to prevent device malfunction or breakdown caused by the current resulting from the inrush current at power ON or the negative current resulting from the back electromotive force at power OFF. IC breakdown may cause injury, smoke or ignition.
Use a stable power supply with ICs with built-in protection functions. If the power supply is unstable, the protection function may not operate, causing IC breakdown. IC breakdown may cause injury, smoke or ignition.
- [4] Do not insert devices in the wrong orientation or incorrectly.
Make sure that the positive and negative terminals of power supplies are connected properly.
Otherwise, the current or power consumption may exceed the absolute maximum rating, and exceeding the rating(s) may cause the device breakdown, damage or deterioration, and may result injury by explosion or combustion.
In addition, do not use any device that is applied the current with inserting in the wrong orientation or incorrectly even just one time.

Points to remember on handling of ICs**(1) Over current Protection Circuit**

Over current protection circuits (referred to as current limiter circuits) do not necessarily protect ICs under all circumstances. If the Over current protection circuits operate against the over current, clear the over current status immediately.

Depending on the method of use and usage conditions, such as exceeding absolute maximum ratings can cause the over current protection circuit to not operate properly or IC breakdown before operation. In addition, depending on the method of use and usage conditions, if over current continues to flow for a long time after operation, the IC may generate heat resulting in breakdown.

(2) Thermal Shutdown Circuit

Thermal shutdown circuits do not necessarily protect ICs under all circumstances. If the thermal shutdown circuits operate against the over temperature, clear the heat generation status immediately.

Depending on the method of use and usage conditions, such as exceeding absolute maximum ratings can cause the thermal shutdown circuit to not operate properly or IC breakdown before operation.

(3) Heat Radiation Design

In using an IC with large current flow such as power amp, regulator or driver, please design the device so that heat is appropriately radiated, not to exceed the specified junction temperature (T_J) at any time and condition. These ICs generate heat even during normal use. An inadequate IC heat radiation design can lead to decrease in IC life, deterioration of IC characteristics or IC breakdown. In addition, please design the device taking into consideration the effect of IC heat radiation with peripheral components.

(4) Back-EMF

When a motor rotates in the reverse direction, stops or slows down abruptly, a current flow back to the motor's power supply due to the effect of back-EMF. If the current sink capability of the power supply is small, the device's motor power supply and output pins might be exposed to conditions beyond maximum ratings. To avoid this problem, take the effect of back-EMF into consideration in system design.

RESTRICTIONS ON PRODUCT USE

070122EBA_R6

- The information contained herein is subject to change without notice. 021023_D
- TOSHIBA is continually working to improve the quality and reliability of its products. Nevertheless, semiconductor devices in general can malfunction or fail due to their inherent electrical sensitivity and vulnerability to physical stress. It is the responsibility of the buyer, when utilizing TOSHIBA products, to comply with the standards of safety in making a safe design for the entire system, and to avoid situations in which a malfunction or failure of such TOSHIBA products could cause loss of human life, bodily injury or damage to property.
In developing your designs, please ensure that TOSHIBA products are used within specified operating ranges as set forth in the most recent TOSHIBA products specifications. Also, please keep in mind the precautions and conditions set forth in the "Handling Guide for Semiconductor Devices," or "TOSHIBA Semiconductor Reliability Handbook" etc. 021023_A
- The TOSHIBA products listed in this document are intended for usage in general electronics applications (computer, personal equipment, office equipment, measuring equipment, industrial robotics, domestic appliances, etc.). These TOSHIBA products are neither intended nor warranted for usage in equipment that requires extraordinarily high quality and/or reliability or a malfunction or failure of which may cause loss of human life or bodily injury ("Unintended Usage"). Unintended Usage include atomic energy control instruments, airplane or spaceship instruments, transportation instruments, traffic signal instruments, combustion control instruments, medical instruments, all types of safety devices, etc. Unintended Usage of TOSHIBA products listed in this document shall be made at the customer's own risk. 021023_B
- The products described in this document shall not be used or embedded to any downstream products of which manufacture, use and/or sale are prohibited under any applicable laws and regulations. 060106_Q
- The information contained herein is presented only as a guide for the applications of our products. No responsibility is assumed by TOSHIBA for any infringements of patents or other rights of the third parties which may result from its use. No license is granted by implication or otherwise under any patents or other rights of TOSHIBA or the third parties. 070122_C
- Please use this product in compliance with all applicable laws and regulations that regulate the inclusion or use of controlled substances.
Toshiba assumes no liability for damage or losses occurring as a result of noncompliance with applicable laws and regulations. 060819_AF
- The products described in this document are subject to foreign exchange and foreign trade control laws. 060925_E