



TOSHIBA Bi-CMOS Constant Current Interface Driver

TB62705CP/CF/CFN

8 Bit Constant Current LED Driver with Shift Register and Latch Functions

Product Description:

The TB62705CP/CF/CFN is specifically designed for LED display applications. The Bi-CMOS device has 8 Bi-Polar constant current output channels and includes CMOS shift register and latch functions.

The LED drive current is programmed by the installation of a single resistor per device. Current is programmable from 5-90mA and is held constant across all 8 outputs effectively compensating for the inherent circuit and component variables which affect the brightness of the LEDs.

Features:

- 8 Constant Current Output Channels
- Current Programmable from 5-90mA
- 5V CMOS Compatible Inputs
- 15MHz Max Clock Frequency (Cascade)

Block Diagram:

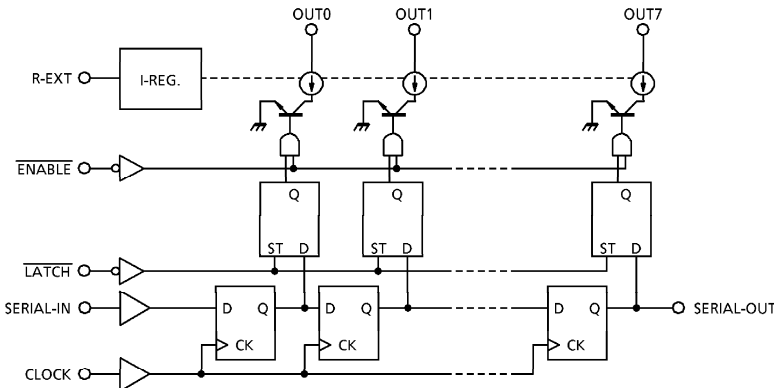

TB62705CP

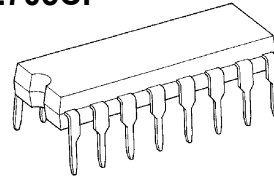

DIP16-P-300-2.54A

Weight: 1.11g(typ)

TB62705CF

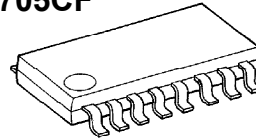

SSOP16-P-225-1.00A

Weight: 0.14g(typ)

TB62705CFN

NEW! Ultra Small Surface Mount Package

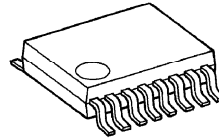

SSOP16-P-225-0.65B

Weight: 0.07g(typ)

Company Headquarters
3 Northway Lane North
Latham, New York 12110
Toll Free: 800.984.5337
Fax: 518.785.4725



Web: www.marktechopto.com | Email: info@marktechopto.com

For up-to-date product info visit our web site at www.marktechopto.com

California Sales Office:

950 South Coast Drive, Suite 265
Costa Mesa, California 92626
Toll Free: 800.984.5337

Fax: 714.850.9314

All specifications subject to change.

TOSHIBA Bi-CMOS Constant Current Interface Driver



TB62705CP/CF/CFN

Timing Diagram:

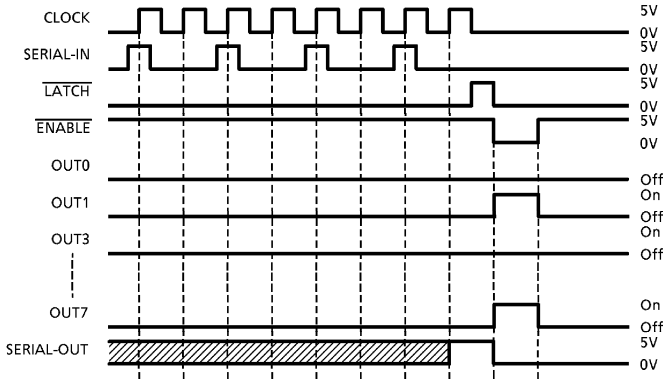

Latches are:

1. Level Sensitive
2. Not edge sensitive
3. Not clock synchronous
4. Passing Data when $\overline{\text{LATCH}}$ is H
5. Hold Data when $\overline{\text{LATCH}}$ is L

All Outputs are OFF when $\overline{\text{ENABLE}}$ is H and ON when $\overline{\text{ENABLE}}$ is L.

Terminal Description & Pin Out:

PIN No.	PIN NAME	FUNCTION
1	GND	GND terminal for control logic
2	SERIAL-IN	Input terminal of a serial-data for shift register
3	CLOCK	Input terminal of a clock for data shift up to edge.
4	$\overline{\text{LATCH}}$	Inout terminal of a data strobe. (Latches pass data with "H" level input of $\overline{\text{LATCH}}$ -terminal, and hold data with "L" level input.)
5~12	OUT0~7	Output terminals
13	$\overline{\text{ENABLE}}$	Input Terminal of output enable. (All outputs (OUT0~7) do off with "H" level input of $\overline{\text{ENABLE}}$ terminal, and on with "L" level input.)
14	SERIAL-OUT	Output terminal of serial data for next SERIAL-IN terminal.
15	R-EXT	Constant Current Programming through external resistor
16	VDD	5V Supply voltage terminal

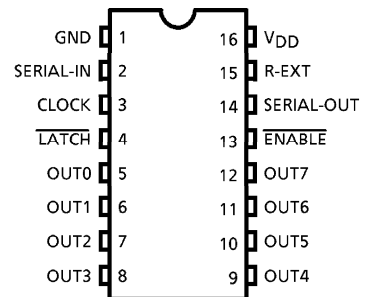

Company Headquarters
 3 Northway Lane North
 Latham, New York 12110
 Toll Free: 800.984.5337
 Fax: 518.785.4725



Web: www.marktechopto.com | Email: info@marktechopto.com

For up-to-date product info visit our web site at www.marktechopto.com

California Sales Office:
 950 South Coast Drive, Suite 265
 Costa Mesa, California 92626
 Toll Free: 800.984.5337
 Fax: 714.850.9314

All specifications subject to change.



TOSHIBA Bi-CMOS Constant Current Interface Driver

TB62705CP/CF/CFN

Truth Table:

CLOCK	LATCH	ENABLE	SERIAL-IN	OUT0	OUT5	OUT7	SERIAL-OUT
UP	H	L	Dn	Dn	Dn-5	Dn-7	Dn-7
UP	L	L	Dn+1	No Change			Dn-6
UP	H	L	Dn+2	Dn+2	Dn-3	Dn-5	Dn-5
DOWN	X	L	Dn+3	Dn+2	Dn-3	Dn-5	Dn-5
DOWN	X	H	DN+3	Off			Dn-5

Equivalent Circuit of Inputs and Outputs:

1. $\overline{\text{ENABLE}}$ terminal

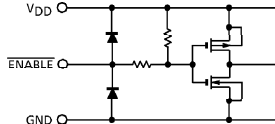

2. $\overline{\text{LATCH}}$ terminal

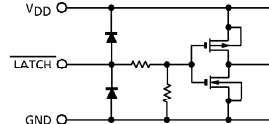

3. CLOCK, SERIAL-IN terminal

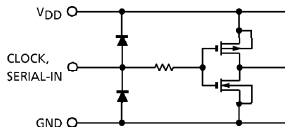

4. SERIAL-OUT terminal

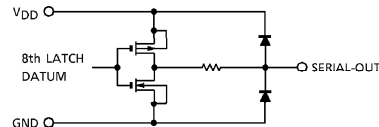

Maximum Ratings:

CHARACTER	SYMBOL	RATING	UNIT
Supply Voltage	VDD	0~+7.0	V
Input Voltage	VIN	-0.4~VDD + 0.4	V
Output Current	IOUT	+90	mA
Output Voltage	VOUT	-0.5~+17.0	V
Clock Frequency	FCLK	15	MHz
GND Terminal Current	IGND	720	mA
Power Dissipation	PD	1.47 (CP type : FREE AIR, Ta=25°C)	W
		0.78 (CF/CFN type : ON PCB, Ta=25°C)	
Thermal Resistance	Rth (j-a)	85 (CP type : FREE AIR, Ta=25°C)	°C / W
		160 (CF/CFN type : ON PCB, Ta=25°C)	
Operating Temperature	Topr	-40~+85	°C
Storage Temperature	Tstg	-55~+150	°C

Company Headquarters
3 Northway Lane North
Latham, New York 12110
Toll Free: 800.984.5337
Fax: 518.785.4725



Web: www.marktechopto.com | Email: info@marktechopto.com

For up-to-date product info visit our web site at www.marktechopto.com

California Sales Office:
950 South Coast Drive, Suite 265
Costa Mesa, California 92626
Toll Free: 800.984.5337
Fax: 714.850.9314

All specifications subject to change.

TOSHIBA Bi-CMOS Constant Current Interface Driver



TB62705CP/CF/CFN

Recommended Operating Condition:

CHARACTERISTIC	SYMBOL	CONDITION	MIN.	TYP.	MAX.	UNIT
Supply Voltage	VDD		4.5	5.0	5.5	V
Output Voltage	VOOUT		—	—	15.0	V
Output Current	IOUT	DC 1 Circuit	5	—	88	mA
	IOH	SERIAL-OUT	—	—	-1.0	mA
	IOL	SERIAL-OUT	—	—	1.0	mA
Input Voltage	VIH		0.7VDD	—	VDD+0.3	V
	VIL		-0.3	—	0.3VDD	V
LATCH Pulse Width	tw LAT	VDD=4.5 ~ 5.5V	100	—	—	ns
CLOCK Pulse Width	tw CLK		50	—	—	ns
ENABLE Pulse Width	tw EN		4500	—	—	ns
Set-up Time for DATA	tsetup(D)		60	—	—	ns
Hold Time for Data	thold(D)		20	—	—	ns
Set-up Time for LATCH	tsetup(L)		100	—	—	ns
Hold Time for ENABLE	thold(L)		60	—	—	ns
Clock Frequency	FCLK	Cascade Operation	1	—	—	MHz
Power Dissipation	PD	Ta=85°C (CP type FREE AIR)	—	—	0.82	W
		Ta=85°C (CF/CFN type ON PCB)	—	—	0.40	

Company Headquarters
3 Northway Lane North
Latham, New York 12110
Toll Free: 800.984.5337
Fax: 518.785.4725



Web: www.marktechopto.com | Email: info@marktechopto.com

For up-to-date product info visit our web site at www.marktechopto.com

California Sales Office:
950 South Coast Drive, Suite 265
Costa Mesa, California 92626
Toll Free: 800.984.5337
Fax: 714.850.9314

All specifications subject to change.



TOSHIBA Bi-CMOS

Constant Current Interface Driver

TB62705CP/CF/CFN

Electrical Characteristics:

CHARACTERISTIC		SYMBOL	TEST CIR-CUIT	CONDITION	MIN.	TYP.	MAX.	UNIT	
Input Voltage	"H" level	V _{IH}	—	—	0.7V _{DD}	—	V _{DD}	V	
	"L" level	V _{IL}	—	—	GND	—	0.3V _{DD}		
Output Leakage Current		I _{OH}	—	VOH=15.0V	—	—	10	μA	
Output Voltage	SERIAL--OUT	V _{OL}	—	I _{OL} =+1.0mA	—	—	0.4	V	
		V _{OH}	—	I _{OH} =-1.0mA	4.6	—	—	V	
Output Current 1		I _{OL1}	—	VCE=0.7V	REXT=470Ω (include Skew)	34.1	40.0	45.9	mA
		I _{OL2}	—	VCE=0.4V		33.7	39.5	45.3	
Current Skew		dI _{OL1}	—	I _O =40mA, VCE=0.4V	REXT=470Ω	—	±1.5	±6.0	%
Output Current 2		I _{OL3}	—	VCE=0.4V	REXT=250Ω (Include Skew)	64.2	75.5	86.8	mA
		I _{OL4}	—	VCE=0.7V		63.8	75.0	86.2	
Current Skew		dI _{OL2}	—	I _O =75mA, VCE=0.7V	REXT=250Ω	—	±1.5	±6.0	%
Supply Voltage Regulation		% / V _{DD}	—	REXT=470Ω Ta=+85°C	—	±1.5	±5.0	% / V	
Pull Up Resistor		R _{IN(up)}	—	—	150	300	600	KΩ	
Pull-down Resistor		R _{IN(down)}	—	—	100	200	400	KΩ	
Supply Current	"OFF"	I _{IDD (off) 1}	—	REXT=OPEN OUT 1~8=off	—	0.6	1.2	mA	
		I _{IDD (off) 2}	—	REXT=470Ω OUT 1~8=off	3.5	5.8	8.0		
		I _{IDD (off) 3}	—	REXT=250Ω OUT 1~8=off	6.5	10.7	15.0		
	"ON"	I _{IDD (on)1}	—	REXT=470Ω OUT 1~8=on	7.0	12.0	18.0		
		I _{IDD (on)2}	—	REXT=250Ω OUT 1~8=on	10.0	22.0	32.0		

Company Headquarters
 3 Northway Lane North
 Latham, New York 12110
 Toll Free: 800.984.5337
 Fax: 518.785.4725



Web: www.marktechopto.com | Email: info@marktechopto.com

For up-to-date product info visit our web site at www.marktechopto.com

California Sales Office:
 950 South Coast Drive, Suite 265
 Costa Mesa, California 92626
 Toll Free: 800.984.5337
 Fax: 714.850.9314

All specifications subject to change.

TOSHIBA Bi-CMOS Constant Current Interface Driver



TB62705CP/CF/CFN

Switching Characteristics:

CHARACTERISTIC		SYMBOL	TEST CIRCUIT	CONDITION	MIN.	TYP.	MAX.	UNIT
Propagation Delay Time ("L" to "H")	SIN-OUTn	tpLH	—	VDD = 5.0V VCE = 0.4V VIH = VDD VIL = GND REXT = 470Ω IOUT = 40mA VL = 3.0V RL = 65Ω CL = 10.5pF	—	1200	1500	ns
	LATCH-OUTn				—	1200	1500	ns
	ENABLE-OUTn				—	1200	1500	ns
	CLK-SOUT				—	30	70	ns
Propagation Delay Time ("H" to "L")	SIN-OUTn	tpHL	—		—	700	1000	ns
	LATCH-OUTn				—	700	1000	ns
	ENABLE-OUTn				—	700	1000	ns
	CLK-SOUT				—	30	70	ns
Pulse Width	CLK	tw CLK	—		—	20	30	ns
	LATCH	tw LAT	—		—	10	25	ns
Set-up Time for Latch	L-H	tsetup LAT	—		—	25	50	ns
	H-L		—		—	25	50	ns
Hold Time for LATCH	L-H	thold LAT	—	—	0	30	ns	
	H-L		—	—	0	30	ns	
Maximum CLOCK Rise Time		tr	—	—	—	10	μs	
Maximum CLOCK Fall Time		tf	—	—	—	10	μs	
Output Rise Time		tor	—	300	600	1000	ns	
Output Fall Time		tof	—	150	300	600	ns	

DC Characteristic Test Circuit:

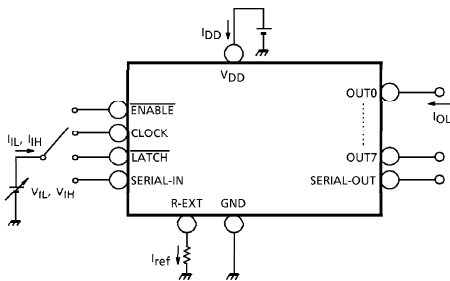

AC Characteristic Test Circuit:

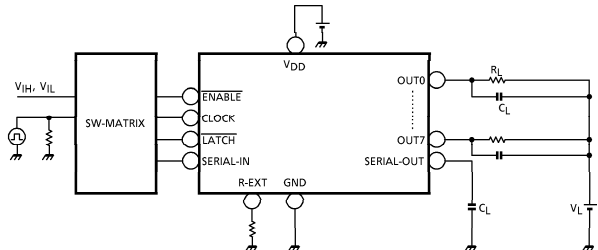

Company Headquarters
3 Northway Lane North
Latham, New York 12110
Toll Free: 800.984.5337
Fax: 518.785.4725



Web: www.marktechopto.com | Email: info@marktechopto.com

For up-to-date product info visit our web site at www.marktechopto.com

California Sales Office:
950 South Coast Drive, Suite 265
Costa Mesa, California 92626
Toll Free: 800.984.5337
Fax: 714.850.9314

All specifications subject to change.



TOSHIBA Bi-CMOS Constant Current Interface Driver

TB62705CP/CF/CFN

Timing Wave Form:

1. CLOCK-SERIAL OUT, OUT_n

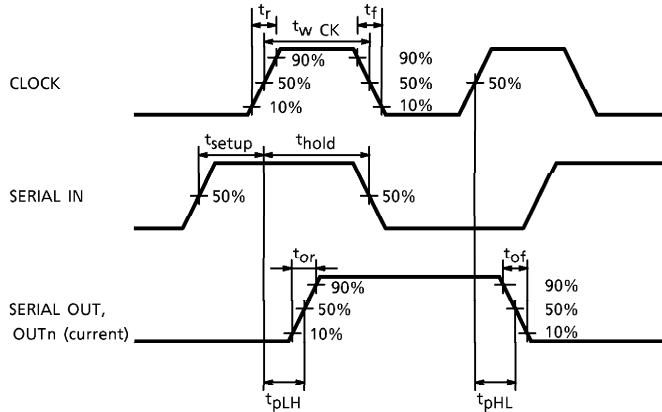

2. CLOCK-LATCH

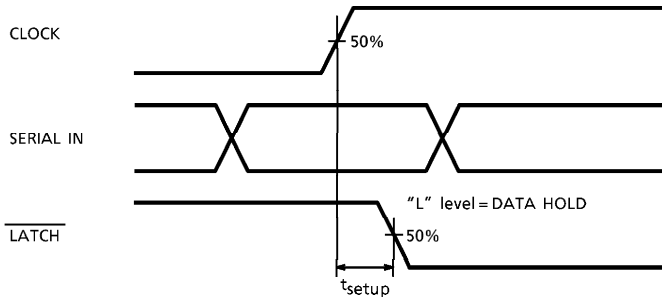

3. ENABLE-OUT_n

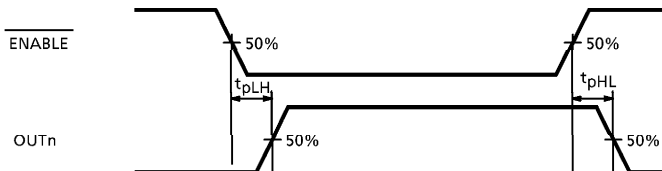

Company Headquarters
3 Northway Lane North
Latham, New York 12110
Toll Free: 800.984.5337
Fax: 518.785.4725



Web: www.marktechopto.com | Email: info@marktechopto.com

For up-to-date product info visit our web site at www.marktechopto.com

California Sales Office:
950 South Coast Drive, Suite 265
Costa Mesa, California 92626
Toll Free: 800.984.5337
Fax: 714.850.9314

All specifications subject to change.

TOSHIBA Bi-CMOS Constant Current Interface Driver



TB62705CP/CF/CFN

Graphs:

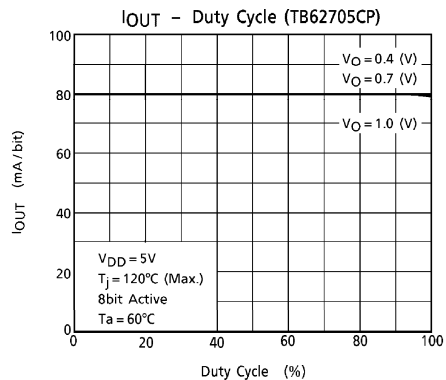
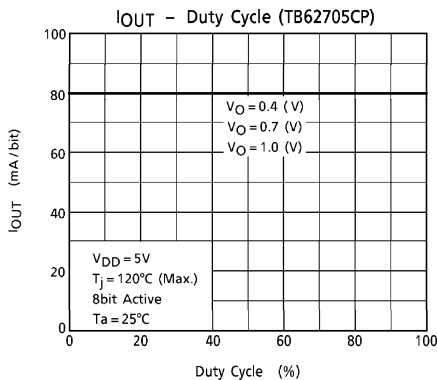
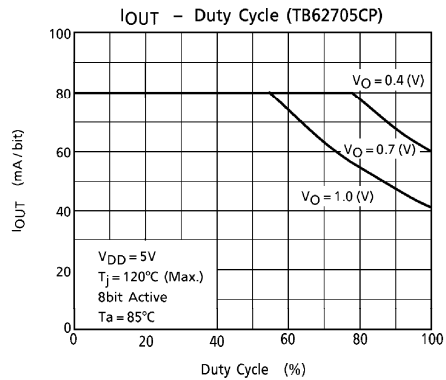
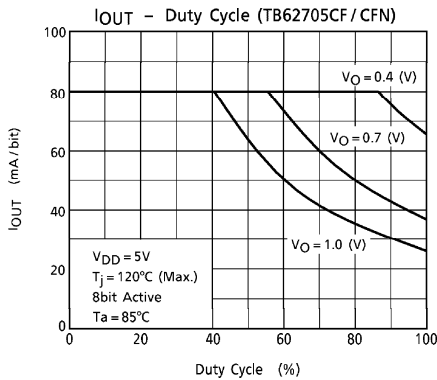
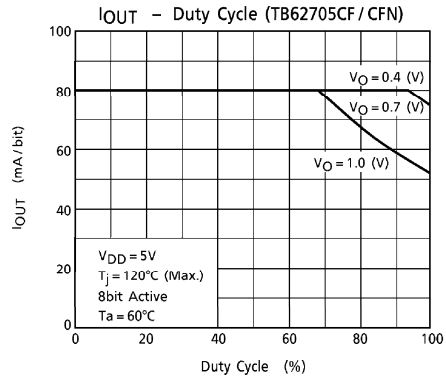
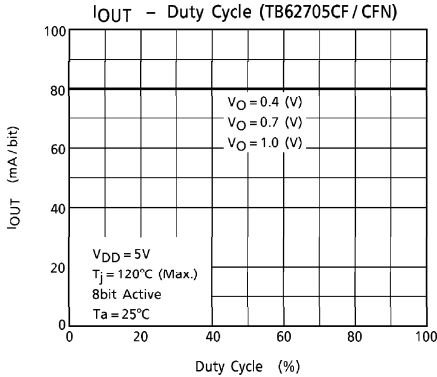

Company Headquarters
 3 Northway Lane North
 Latham, New York 12110
 Toll Free: 800.984.5337
 Fax: 518.785.4725



Web: www.marktechopto.com | Email: info@marktechopto.com

For up-to-date product info visit our web site at www.marktechopto.com

California Sales Office:
 950 South Coast Drive, Suite 265
 Costa Mesa, California 92626
 Toll Free: 800.984.5337
 Fax: 714.850.9314

All specifications subject to change.



TOSHIBA Bi-CMOS Constant Current Interface Driver

TB62705CP/CF/CFN

Current Programming Resistor Selection:

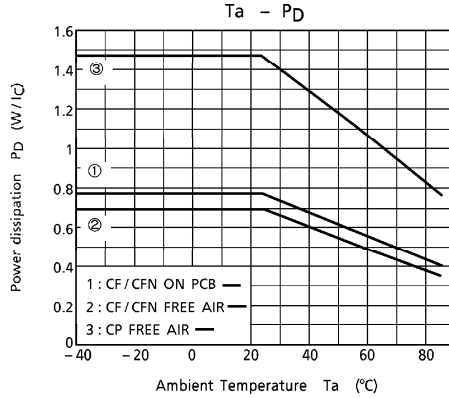
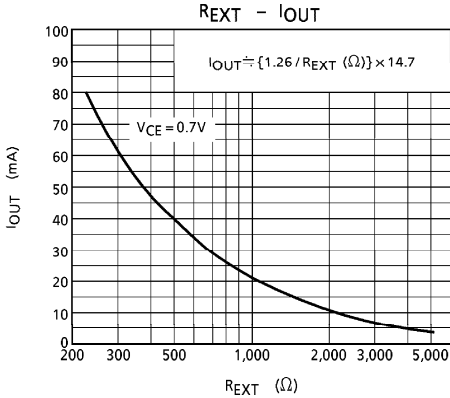

TB62705CP Outline Drawing:

DIP16-P-300-2.54A

Unit : mm

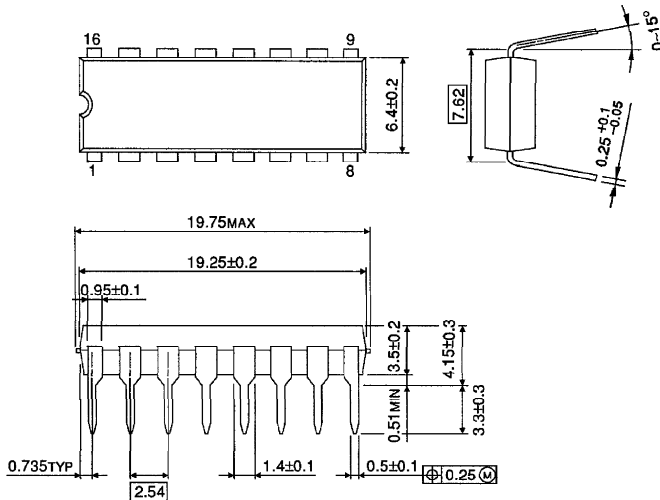

Weight : 1.11g (Typ.)

Company Headquarters

3 Northway Lane North
Latham, New York 12110
Toll Free: 800.984.5337
Fax: 518.785.4725



Web: www.marktechopto.com | Email: info@marktechopto.com

For up-to-date product info visit our web site at www.marktechopto.com

California Sales Office:

950 South Coast Drive, Suite 265
Costa Mesa, California 92626
Toll Free: 800.984.5337
Fax: 714.850.9314

All specifications subject to change.

TOSHIBA Bi-CMOS Constant Current Interface Driver



TB62705CP/CF/CFN

TB62705CF Outline Drawing:

SSOP16-P-225-1.00A

Unit : mm

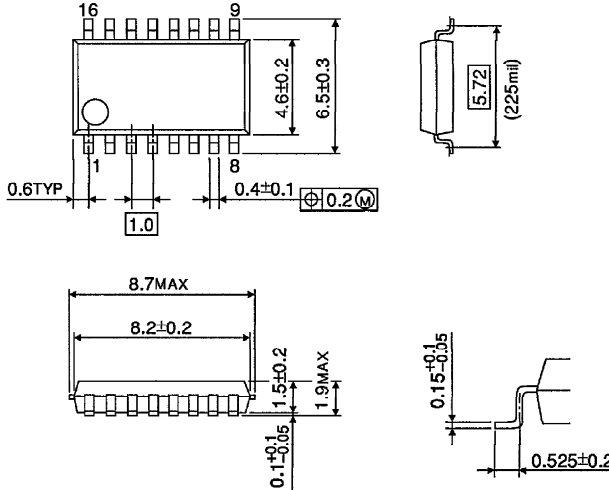

Weight : 0.14g (Typ.)

TB62705CFN Outline Drawing:

SSOP16-P-225-0.65B

Unit : mm

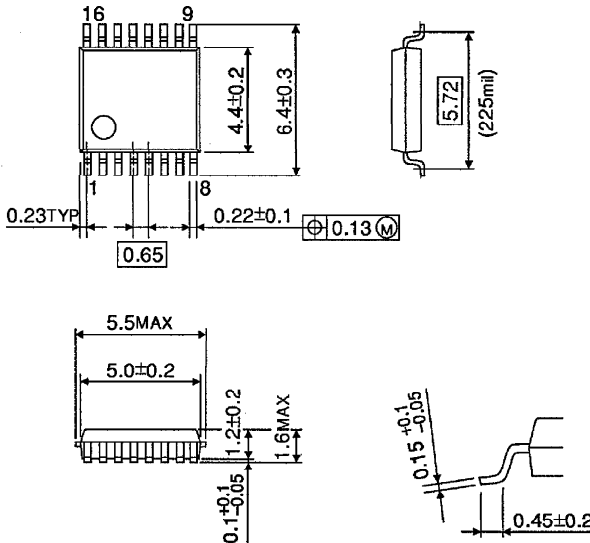

Weight : 0.07g (Typ.)

Company Headquarters

3 Northway Lane North
Latham, New York 12110
Toll Free: 800.984.5337
Fax: 518.785.4725



Web: www.marktechopto.com | Email: info@marktechopto.com

For up-to-date product info visit our web site at www.marktechopto.com

California Sales Office:

950 South Coast Drive, Suite 265
Costa Mesa, California 92626
Toll Free: 800.984.5337

Fax: 714.850.9314

All specifications subject to change.