

**TENTATIVE** TOSHIBA Bi-CMOS Integrated Circuit Silicon Monolithic

# TB32301AFL

## 2.4-GHz Radio Communication IC

### Features

- Consumption current : 35 mA (typ.) (at reception)  
: 26 mA (typ.) (at transmission)
- Operating power supply voltage  
: 2.7 V to 3.3 V (operating temperature range: -20°C to 70°C)
- Ultra-compact package: 36-pin QON
- On-chip LNA
- On-chip VCO
- On-chip PA

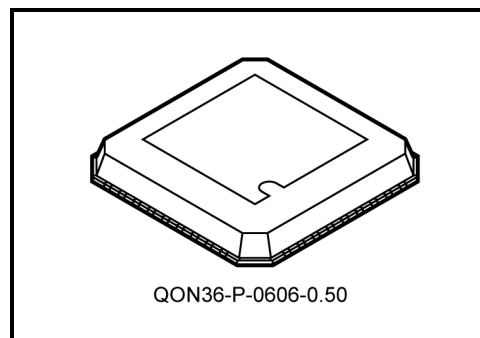

Weight: 0.08 g (typ.)  
Marking: TB32301AFL

### Block Diagram

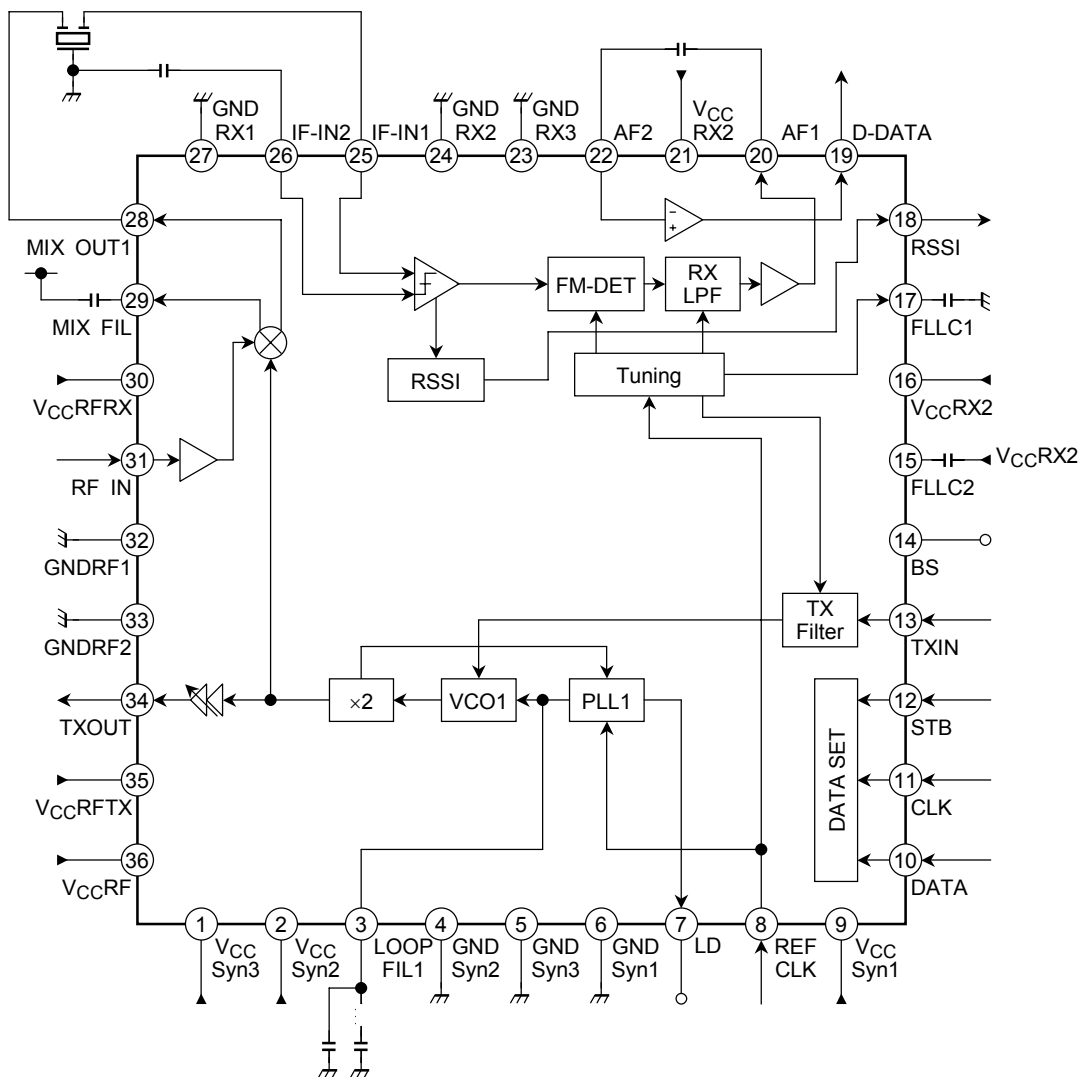

This product is sensitive to electrostatic discharge. When handling the product, ensure that the environment is protected against electrostatic discharge.

## Pin Functions (typical resistor and capacitor values)

Pin No.	Pin Name	Function	Equivalent Circuit
1	V <sub>CC</sub> Syn3	Power supply pin	—
2	V <sub>CC</sub> Syn2	Power supply pin	—
3	LOOPFIL1	External pin for loop filter	
4	GNDSyn2	Ground pin	—
5	GNDSyn3	Ground pin	—
6	GNDSyn1	Ground pin	—
7	LD	PLL lock detector output pin	
8	REFCLK	Reference clock input pin for PLL, TX filter and IF auto tuning	
9	V <sub>CC</sub> Syn1	Power supply pin	—
10	DATA	Serial data input pin	
11	CLK	Serial clock input pin	
12	STB	Serial strobe input pin	
13	TXIN	Transmit signal input pin	

Pin No.	Pin Name	Function	Equivalent Circuit
14	BS	Battery-saving pin	
15, 17	FLLC2 FLLC1	Auto-tuning pin. External capacitor determines the time constant of auto-tuning circuit.	
16	V <sub>CC</sub> RX2	Power supply pin	—
18	RSSI	This pin drives out DC voltage according to the RF input signal level.	
19	DDATA	Comparator output pin	
20	AF1	Demodulation signal output pin	

Pin No.	Pin Name	Function	Equivalent Circuit
21	V <sub>CCRX1</sub>	Power supply pin	—
22	AF2	Comparator input pin	
23	GNDRX2	Ground pin	—
24	GNDRX1		
25	IFIN1	IF amplifier input pin	
26	IFIN2		
27	GNDRF3	Ground pin	—
28	MIXOUT1	Mixer output pin	
29	MIXFIL	Mixer filter pin	
30	V <sub>CCRF1</sub>	Power supply pin	—
31	RFIN	RF signal input pin	

Pin No.	Pin Name	Function	Equivalent Circuit
32	GNDRF1	Ground pin	—
33	GNDRF2		
34	TXOUT	RF signal output pin	—
35	V <sub>CC</sub> RF2	Power supply pin	—
36	V <sub>CC</sub> RF3	Power supply pin	—

Note: The equivalent circuit diagrams above are intended as an aid for designing external circuits. They do not show the exact layout of the internal circuits.

## Power Supply

Power Supply Name	Pin No.	Ground Relevant Pin Name	Pin No.	Block Name
V <sub>CC</sub> Syn3	1	GND Syn3	5	VCO Doubler
V <sub>CC</sub> Syn2	2	GND Syn2	2	VCO1
V <sub>CC</sub> Syn1	9	GND Syn1	6	PLL, DATA SET
V <sub>CC</sub> RX2	16	GND RX3	23	Tuning (FLL), RX-AMP, RX-LPF, DATA COMP, FM-DET
V <sub>CC</sub> RX1	21	GND RX2	24	TX-FILTER, PA, RSSI, IF-AMP, (IF-BPF)
V <sub>CC</sub> RFRX	30	GND RF1 GND RF2	32 33	LNA
V <sub>CC</sub> RX TX	35	GND RX1 GND RF1 GND RF2	27 32 33	PA
V <sub>CC</sub> RF	36	GND RX1 GND RF1 GND RF2	27 32 33	PA, MIXER, LNA

Supplementary: Pins as shown below are shorted together.

- (1) V<sub>CC</sub> RX TX (35 pin) – V<sub>CC</sub> Syn2 (2 pin)
- (2) V<sub>CC</sub> RF (36 pin) – V<sub>CC</sub> RFRX (30 pin)

**Functions and Operation**

**1. Serial data input timing chart**

- Data to control the TB32301AFL is serially applied to pins CLK, DATA and STB.
- Data is loaded into shift registers with MSB first on the rising edge of the clock and latched on the rising edge of the STB signal. When the STB pin is high, the data stored in the shift register is retained even if clock is applied. When the STB pin is low, the data can be rewritten.
- Input timings of the CLK, DATA and STB are shown below.

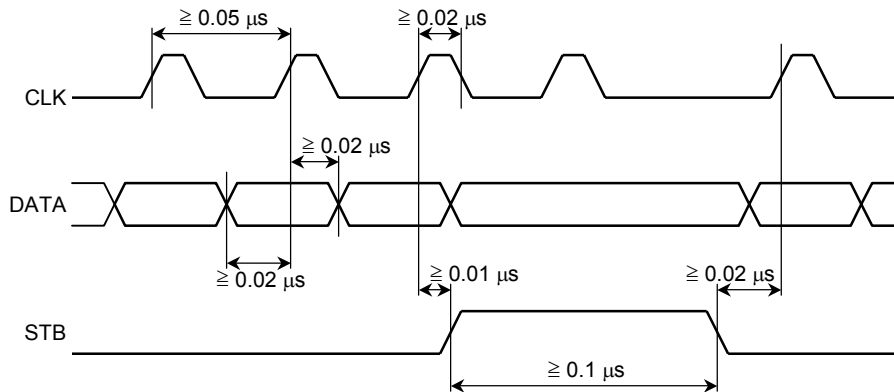

**2. Serial data control contents**

The TB32301F has five types of control contents. These types are determined by serial input 5-bit register address (group code). The control contents consist of PLL main counter setting, PLL reference counter setting, auto-tuning reference counter setting, transmit power amplifier gain setting and system control setting. These settings are controlled independently one another.

**2.1 Register address setting table (group code)**

GC4	GC3	GC2	GC1	GC0	Control Contents
0	0	0	0	0	PLL main counter setting
0	0	0	0	1	PLL reference counter setting
0	0	0	1	0	Auto-tuning reference counter setting
0	0	0	1	1	Transmit power amplifier gain setting
0	0	1	0	0	System control register setting

**2.2 PLL main counter setting**

- The PLL main counter employs a swallow counter.
- It consists of 6-bit swallow counter, 9-bit programmable counter and 1/64, 1/65 2-modulus prescaler.
- The divide factor can be set in the range 4032 to 32767 by sending any data to the swallow counter and the programmable counter.

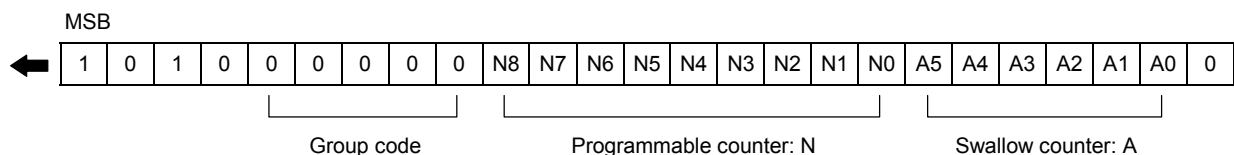

$$A = A0 + A1 \times 2^1 + A2 \times 2^2 + \dots + A5 \times 2^5$$

$$N = N0 + N1 \times 2^1 + N2 \times 2^2 + \dots + N8 \times 2^8$$

$$(\text{Divide factor}) = 64N + A$$

$$4032 \leq (\text{Divide factor}) \leq 32767$$

**2.3 PLL reference counter setting**

- The PLL reference counter generates phase comparison frequency0.
- It consists of 9-bit reference counter. The divide factor can be set in the range 4 to 511 by sending any data to the reference counter.

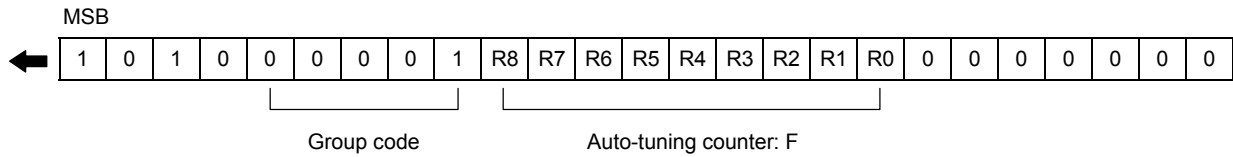

$$R = R0 + R1 \times 2^1 + R2 \times 2^2 + \dots + R8 \times 2^8$$

(Divide factor) = R

$$4 \leq (\text{Divide factor}) \leq 511$$

**2.4 Auto-tuning reference counter setting**

- The TB32301AFL has an automatic tuning system to correct the fluctuation of center frequency in FM detector, which is caused by, for example, temperature change. To generate a reference clock to correct the fluctuation, set the divide factor of auto-tuning reference counter to the value to obtain 200-kHz frequency, according to external reference clock frequency.
- The auto-tuning reference counter consists of 8 bits.
- The divide factor can be set in the range 6 to 255 by sending any data to the reference counter.

$$F = F0 + F1 \times 2^1 + F2 \times 2^2 + \dots + F7 \times 2^7$$

(Divide factor) = F

$$6 \leq (\text{Divide factor}) \leq 255$$

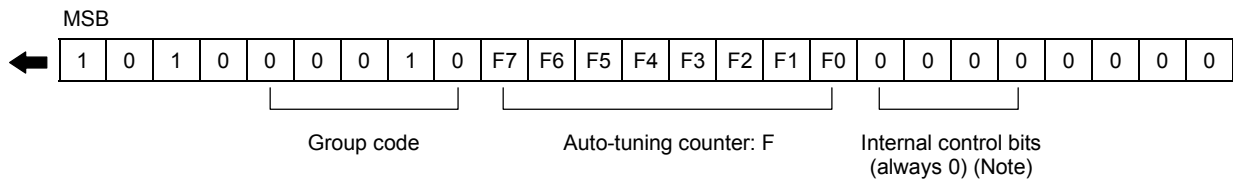

Note Internal control bits are used to control the PLL. Please clear the bits. Otherwise, the PLL may not operate properly.



**2.5 Transmit power amplifier setting**

Applying data serially to pins CLK, DATA and STB changes the gain of the transmit power amplifier. The power control counter consists of 5 bits.

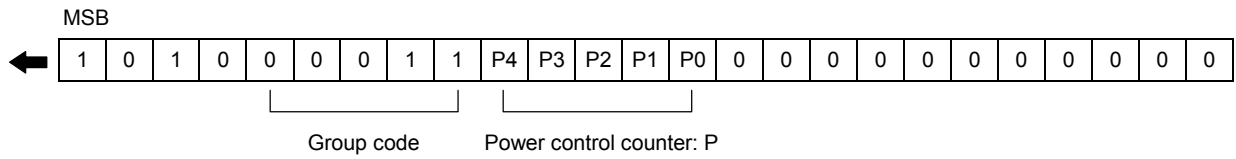

$$(\text{Control step number}) = P0 + P1 \times 2^1 + P2 \times 2^2 + \dots + P4 \times 2^4$$

2.6 System control register setting

In the system control register, applying data serially to pins CLK, DATA and STB sets the optional functions as described below.

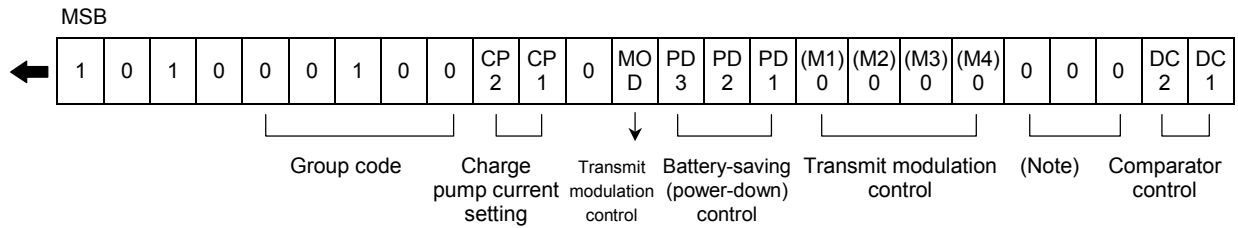

Note: Please clear the bits.

- PLL charge pump current setting (CP1 and CP2 bits: 2.4 GHz)  
 The TB32301AFL contains a constant current charge pump circuit.  
 The output current of the circuit can be selected by setting the CP1 and CP2 bits.

CP2	CP1	Charge Pump Current
0	0	4 mA
0	1	2 mA
1	0	1 mA

- Transmit data timing setting (MOD bit)  
 Clearing the MOD bit makes the VCO circuit oscillate at the center frequency, which is controlled by the PLL. The circuit is not controlled by received data.

MOD	Transmit Data Timing
0	Modulator OFF
1	Modulator ON

- Battery-saving (power-down) mode setting (PD1, PD2 and PD3 bits)  
 Setting the PD1, PD2 and PD3 bits controls the circuits in the reception and transmission blocks. The settings of the external BS control pin (14 pin) and the control bits are shown in the table below.

BS	Control Bits			Reception Block					Transmission Block		Common Block	
	PD3	PD2	PD1	LNA	MIX	IF-AMP	FM-DET	RX-LPF	PA	TX-LPF	PLL, VCO	Auto tuning
L	*	*	*	OFF	OFF	OFF	OFF	OFF	OFF	OFF	OFF	OFF
H	1	1	1	OFF	OFF	OFF	OFF	OFF	OFF	OFF	OFF	OFF
H	1	0	0	OFF	OFF	OFF	OFF	OFF	OFF	OFF	ON	ON
H	1	0	1	OFF	OFF	OFF	OFF	OFF	ON	ON	ON	ON
H	0	0	1	OFF	OFF	OFF	OFF	OFF	OFF	ON	ON	ON
H	0	0	0	ON	ON	ON	ON	ON	OFF	OFF	ON	ON
H	0	1	1	OFF	OFF	OFF	OFF	OFF	OFF	OFF	OFF	ON

- Transmit modulation control bits (M1 to M4 bits)  
 M1 to M4 bits are cleared for normal operation, however, M2 to M4 bits can be set to high to control the transmit modulation as shown below.

M1	M2	M3	M4	Transmit Modulation
0	0	0	0	Normal modulation
0	1	1	1	Normal modulation × 16/8

- Rise time constant setting of comparator reference level (D1 and D2 bits)  
The rise time constant of data comparator reference level is determined by an external capacitance and an internal resistance. The internal resistance can be selected by applying data serially to pins CLK, DATA and STB.

(Rise time constant) = (External capacitance: C) × (Internal resistance: R)

DC2	DC1	Internal Resistance: R
0	0	10 kΩ
0	1	10 kΩ
1	0	100 kΩ
1	1	1000 kΩ

**3. Image canceller mixer in reception block**

The TB32301AFL contains an image canceller mixer as the first stage of the reception block. The image canceller mixer is designed for upper local, therefore, please set the local signal frequency to  $f_0$  (desired reception frequency) + 11 MHz (IF frequency).

**4. Lock detector function (LD pin: 7 pin)**

The TB32301AFL incorporates VCO lock detector function.

When a phase error is detected in the phase comparator, 0 is driven out from the LD pin. When the VCO is locked or all the circuits are OFF, 1 is driven out from the pin.

**5. VCO modulation polarity and demodulation data polarity**

- VCO modulation polarity

Transmit Data	VCO Frequency Deviation
1	Positive (+) polarity
0	Negative (-) polarity

- Demodulation data polarity

The polarity of the data, which is demodulated by the FM detector and the data comparator, is the same as that of transmit data.

At Transmission	At Reception	
	FM Detector	Data Comparator Output
1	Positive (+) polarity	1
0	Negative (-) polarity	0

## Electrical Characteristics

### Maximum Ratings

Characteristics	Symbol	Rating	Unit
Power supply voltage	VCC_A, VCC_D	3.6	V
Power dissipation	PD	530	mW
Input pin voltage	CLK, DATA, STB, BS, LD, TXIN	3.6	V
Storage temperature range	Tstg	-50 to 150	°C

Note 1: Maximum ratings are a set of specified parameter values which must not be exceeded during operation, even for an instant.

### Operating Ratings

Characteristics	Symbol	Test Circuit	Test Condition	Rating	Unit
Operating voltage	Vopr1	—	Ta = 25°C, ground reference	2.7 to 3.3	V
Operating temperature	Topr1	—		-20 to 70	°C

Note 2: These ratings specify the ranges within which the device can operate its basic functions, even when fluctuations in its electrical characteristics occur.

## Electrical Characteristics

(Unless otherwise specified, Ta = 25°C, VCC = 3.0 V, f = 2450 MHz, Bit Rate = 100kHz, PA bit setting = 21, Dev = ± 160 kHz)

### Power Supply

Characteristics	Symbol	Test Circuit	Test Condition	Min	Typ.	Max	Unit
Current consumption 1 at no signal	ICC1	1	At reception BS = H, PD1 = 0, PD2 = 0, PD3 = 0 (Note 3)	28.0	35.1	42.0	mA
Current consumption 2 at no signal	ICC2	1	At transmission BS = H, PD1 = 1, PD2 = 0, PD3 = 1 (Note 3)	19	25.6	42	mA
Supply current at no signal	ICCQ1	1	In battery-saving mode BS = L, PD1 = 1, PD2 = 1 PD3 = 1 (Note 3)	—	0	10	μA
High-level input voltage	VIH	—	CLK, DATA, STB, BS, TXIN	$V_{CC} \times 0.8$	VCC	$V_{CC} + 0.2$	V
Low-level input voltage	VIL	—	CLK, DATA, STB, BS, TXIN	-0.2	0	$V_{CC} \times 0.2$	V

Note 3: Please refer to Section 2.6 “System control register setting”.

### Integrated Characteristics

Characteristics	Symbol	Test Circuit	Test Condition	Min	Typ.	Max	Unit
Minimum input level	VIN(min)	1	S/N = 20dB	-	20.4	-	dBμV
Demodulation output level	Vod	—	Vin (LNA) = 70dBμV	-	450	-	mVp-p

## Electrical Characteristics

(Unless otherwise specified, Ta = 25°C, VCC = 3.0 V, f = 2450 MHz, Bit Rate = 100kHz, PA = 21 setting, Dev = ± 160 kHz)

### LNA and Mixer Blocks

Mixer image rejection ratio	IRR	1		20	33	—	dB
Output impedance	R-OUT (MIX)	—		—	470	—	Ω
Output capacitance	C-OUT (MIX)	—		—	2	—	pF
Operating frequency range (LNA and mixer)	Fopr (LNA + MIX)	1		2400	—	2500	MHz
Intercept point 1 output (LNA and mixer)	OIP3-1 (LNA + MIX)	—	f1 (UD1) = 2453 MHz, UD1: No modulation f2 (UD2) = 2456 MHz, UD2: No modulation	—	85	—	dBμV

### IF Amplifier, DET and RX-LPF Blocks

RSSI output voltage 1	V (RSSI-1)	1	Vin (IF) = 41dBμV, No modulation	0.36	0.54	0.72	V
RSSI output voltage 2	V (RSSI-2)	1	Vin (IF) = 91dBμV, No modulation	(1.25)	(1.75)	(2.25)	V
IF amplifier input impedance	R-IN (IF)	—		—	720	—	Ω
IF amplifier input capacitance	C-IN (IF)	—		—	2	—	pF

### Comparator

Duty ratio	COMP (duty)	1	Open-drain output Internal time constant setting 1 (10 kΩ)	40	50	60	%
High-level leakage current	I (COMP-LEAK)	1	Open-drain output	—	0	5	μA
Output ON resistance	R (COMP-L)	—	IL = 100 μA	—	1	—	kΩ

### PLL Block

Lock-up time	t-lock	1	Phase comparison frequency: 500 kHz Charge pump output current = 4 mA	—	150	—	μs
Reference clock operating frequency range	fxin	1		4	—	20	MHz
Reference clock input level range	vxin	1		92	100	112	dBμV
Clock (serial data) input frequency	fclk	1		—	—	20	MHz
Charge pump output current 1	Icp (1)	1	Vcp = 1/2VCC	350	500	650	μA
Charge pump output current 2	Icp (2)	1	Vcp = 1/2VCC	0.7	1	1.3	mA
Charge pump output current 3	Icp (3)	1	Vcp = 1/2VCC	1.4	2	2.6	mA
Charge pump output current 4	Icp (4)	1	Vcp = 1/2VCC	2.8	4	5.2	mA
LD OFF leakage current	LD-off-LEAK	1	Open-drain output	—	0	5	μA
LD ON resistance	R(LD-on)	1	Open-drain output	—	1	—	kΩ

### VCO Block

VCO Oscillation frequency range (× 2)	f (VCO)	1		2400	—	2500	MHz
VCO gain (× 2)	Kv	—		—	120	—	MHz/V
VCO phase noise (× 2)	pn1	—	@500 kHz	—	107	—	dBc/Hz
	pn2	—	@2 MHz	—	119	—	dBc/Hz

## Electrical Characteristics

(Unless otherwise specified,  $T_a = 25^\circ\text{C}$ ,  $V_{CC} = 3.0\text{ V}$ ,  $f = 2450\text{ MHz}$ , Bit Rate = 100kHz, PA = 21 setting, Dev =  $\pm 160\text{ kHz}$ )

### Transmission Block

Tx data input level	$V_{tx}$	—		$V_{CC} \times 0.8$	$V_{CC}$	$V_{CC} + 0.2$	V
Local leakage spurious	SPRlo	1	Test frequency: 1.225 GHz	—	-30	-20	dBm
Maximum frequency deviation	dev (tx)	1	On loop, fBB=100kHz (CW)	(140)	(190)	(230)	KHz

### PA Block

Nominal output signal level	PA-OUT (nom.)	1	DATA21 set for PA output	(-9)	(-3)	—	dBm
Minimum output signal level	PA-OUT (min.)	1	DATA3 set for PA output	—	(-30)	(-25)	dBm
Output impedance	Z-OUT (PA)	1		—	50	—	$\Omega$

## Test Circuit 1

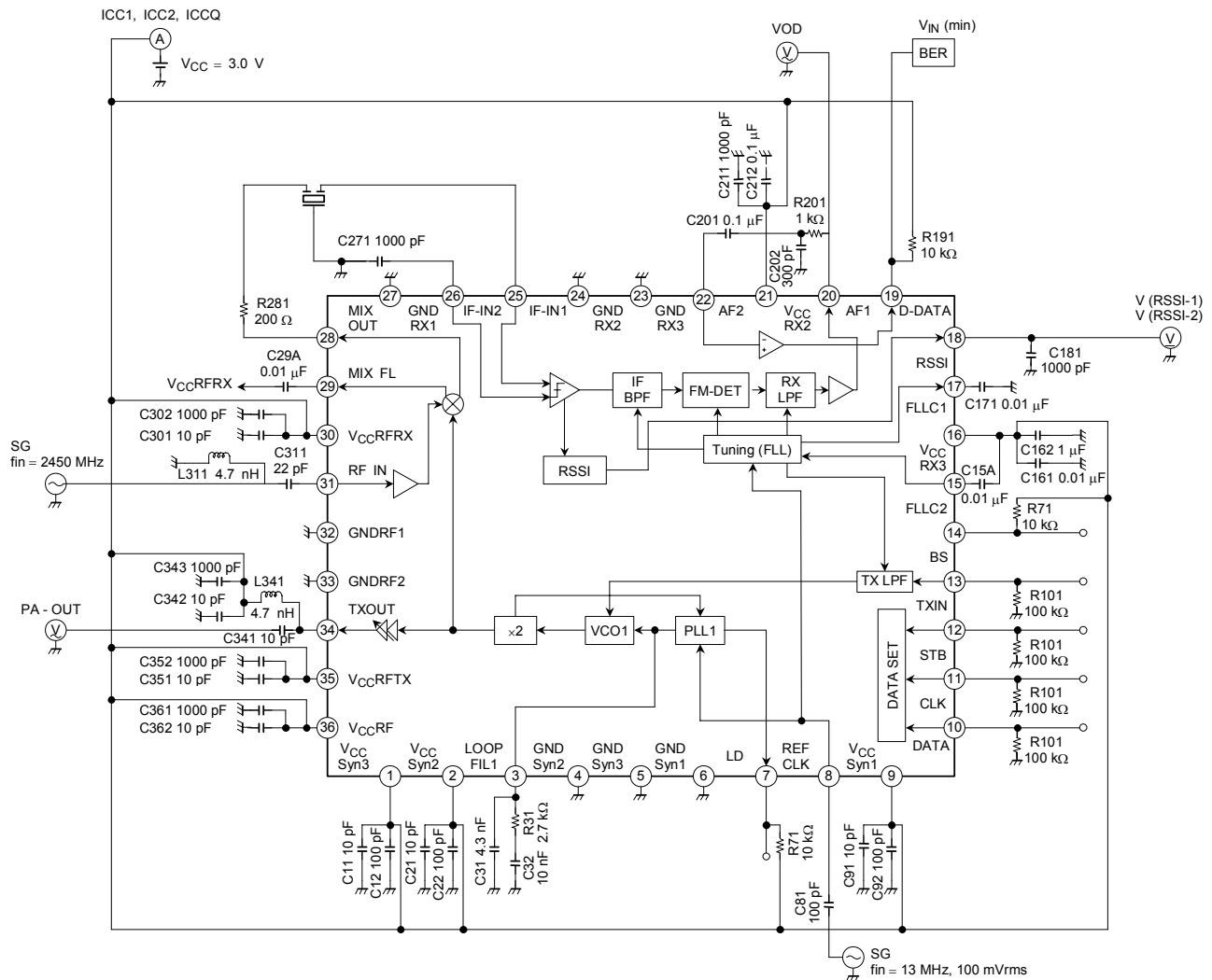

- (1) Detailed test condition of minimum input level in the integrated characteristics
  - Detector LPF: C202 = 300 pF, R201 = 1 k $\Omega$  and  $f_T$  = 530 kHz
  - Total bits: 1.6 Mbits
  - Data comparator output: Monitors using a probe.
  - Input/output: LNA input, data comparator output
  - Transmission modulation (DEV): 157.5 kHz
  - Data: PRBS9 (1MBPS)
  - BT = 0.5 gaussian filter
  - IF filter used. (Note)
  - Tested using a Toshiba's mounting board

Note: Ceramic filter manufacturer and product no.

SFSCB11M0WF manufactured by Murata Manufacturing Co., Ltd.

- (2) Detailed test condition in the transmission block
  - Tested using a Toshiba's mounting board
- (3) Detailed test condition of output level in the PA block
  - Tested using a Toshiba's mounting board

Package Dimensions

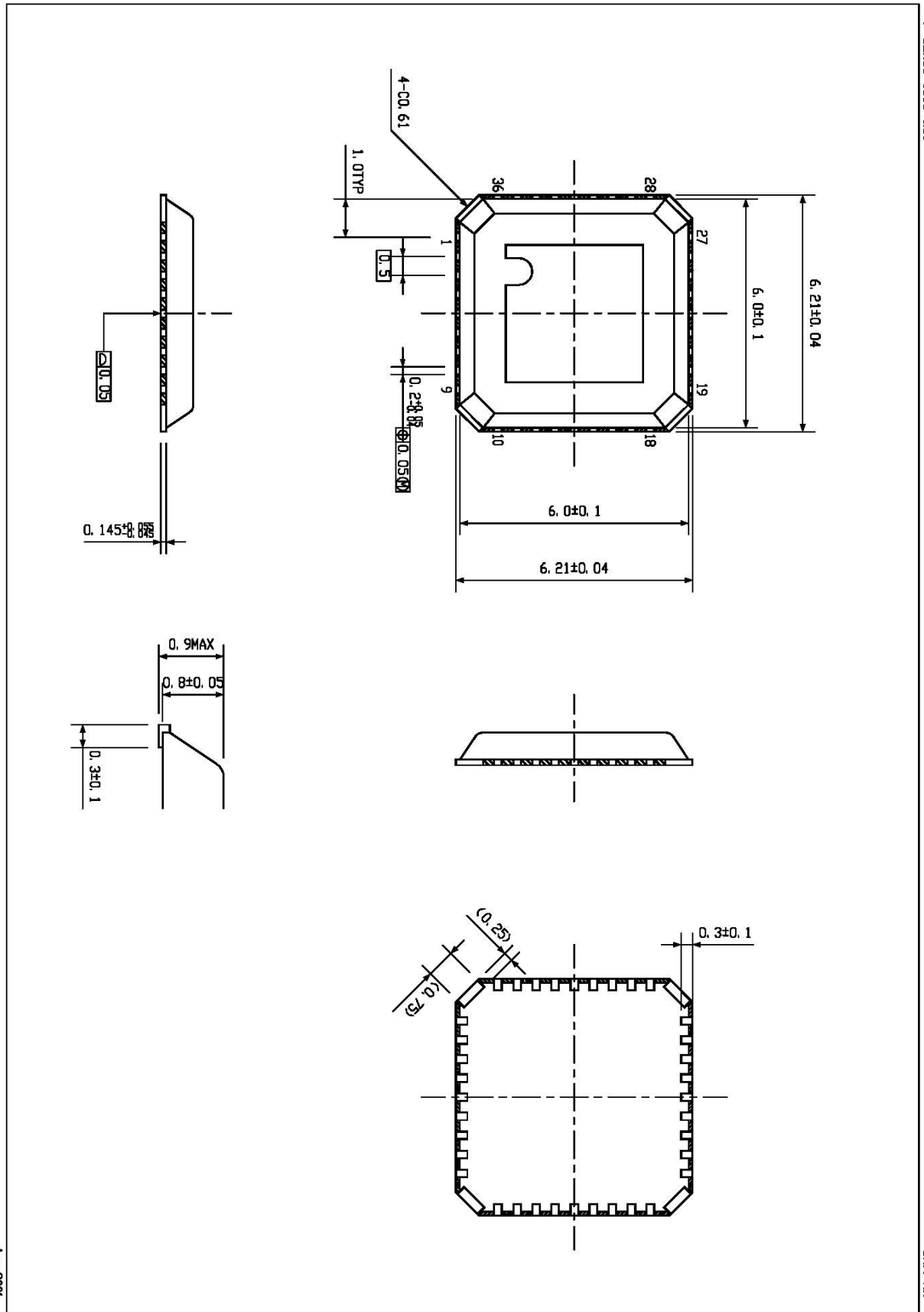

P-Q0N36-0606-0-50

Unit: mm

Apr. 2001

Weight: 0.08 g (typ.)



**RESTRICTIONS ON PRODUCT USE**

000707EBA

- TOSHIBA is continually working to improve the quality and reliability of its products. Nevertheless, semiconductor devices in general can malfunction or fail due to their inherent electrical sensitivity and vulnerability to physical stress. It is the responsibility of the buyer, when utilizing TOSHIBA products, to comply with the standards of safety in making a safe design for the entire system, and to avoid situations in which a malfunction or failure of such TOSHIBA products could cause loss of human life, bodily injury or damage to property.  
In developing your designs, please ensure that TOSHIBA products are used within specified operating ranges as set forth in the most recent TOSHIBA products specifications. Also, please keep in mind the precautions and conditions set forth in the "Handling Guide for Semiconductor Devices," or "TOSHIBA Semiconductor Reliability Handbook" etc..
- The TOSHIBA products listed in this document are intended for usage in general electronics applications (computer, personal equipment, office equipment, measuring equipment, industrial robotics, domestic appliances, etc.). These TOSHIBA products are neither intended nor warranted for usage in equipment that requires extraordinarily high quality and/or reliability or a malfunction or failure of which may cause loss of human life or bodily injury ("Unintended Usage"). Unintended Usage include atomic energy control instruments, airplane or spaceship instruments, transportation instruments, traffic signal instruments, combustion control instruments, medical instruments, all types of safety devices, etc.. Unintended Usage of TOSHIBA products listed in this document shall be made at the customer's own risk.
- The products described in this document are subject to the foreign exchange and foreign trade laws.
- The information contained herein is presented only as a guide for the applications of our products. No responsibility is assumed by TOSHIBA CORPORATION for any infringements of intellectual property or other rights of the third parties which may result from its use. No license is granted by implication or otherwise under any intellectual property or other rights of TOSHIBA CORPORATION or others.
- The information contained herein is subject to change without notice.