

TA8429H

3.0A FULL BRIDGE DRIVER

The TA8429H is full bridge driver IC for brush motor rotation control that has current capability of up to 3.0A (AVE.).

Thermal shutdown and short current protector are provided.

And also stand-by function available.

FEATURES

- Output current is as large as 3.0A (AVE.) and 4.5A (PEAK.)
- Stand-by mode available : $I_{ST} \leq 100\mu A$ (MAX.)
- Thermal shutdown and short circuit protector circuit are provided.
- 4 modes (Forward / reverse / short brake and stop) are available with 2 low active TTL compatible inputs control.
- Free wheeling diodes are equipped.
- HZIP power package sealed.
- Wide range of operating voltage : $V_{CC} = 7 \sim 27V$
 V_S (opr.) = $0 \sim 27V$

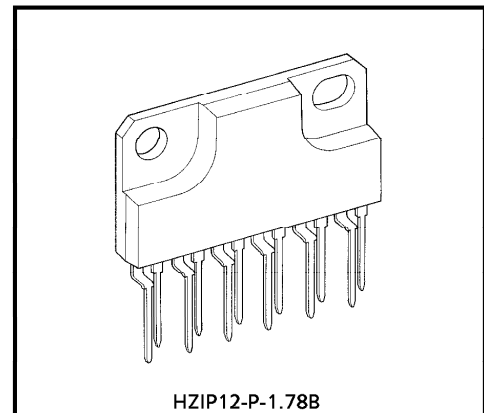

Weight : 4.04g (Typ.)

BLOCK DIAGRAM

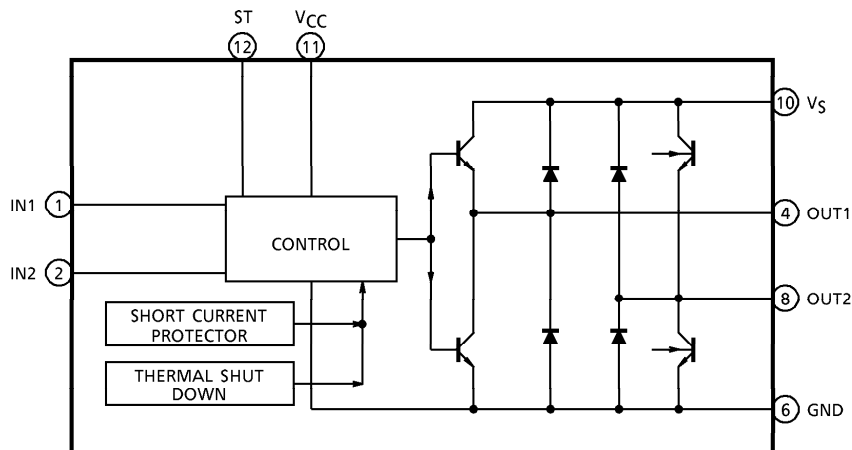

(Note 1) Pin③, ⑤, ⑦, and ⑨ are non connection.

(Note 2) Heat fin is connected with GND with low impedance.

961001EBA2

● TOSHIBA is continually working to improve the quality and the reliability of its products. Nevertheless, semiconductor devices in general can malfunction or fail due to their inherent electrical sensitivity and vulnerability to physical stress. It is the responsibility of the buyer, when utilizing TOSHIBA products, to observe standards of safety, and to avoid situations in which a malfunction or failure of a TOSHIBA product could cause loss of human life, bodily injury or damage to property. In developing your designs, please ensure that TOSHIBA products are used within specified operating ranges as set forth in the most recent products specifications. Also, please keep in mind the precautions and conditions set forth in the TOSHIBA Semiconductor Reliability Handbook.

PIN FUNCTION

PIN No.	SYMBOL	FUNCTIONAL DESCRIPTION
1	IN1	TTL compatible control inputs (PNP type low active comparator inputs)
2	IN2	
3	N.C	Non connection
4	OUT1	Output terminals, free wheeling diodes are connected between each output with GND and V_S .
5	N.C	Non connection
6	GND	GND terminal
7	N.C	Non connection
8	OUT2	Output terminals, free wheeling diodes are connected between each output with GND and V_S .
9	N.C	Non Connection
10	V_S	Supply voltage terminal for Motor Drive
11	V_{CC}	Supply voltage terminal for control circuit
12	ST	Stand-by terminal. Stand-by state is obtained with this terminal connected with GND (or Open).

961001EBA2'

- The products described in this document are subject to foreign exchange and foreign trade control laws.
- The information contained herein is presented only as a guide for the applications of our products. No responsibility is assumed by TOSHIBA CORPORATION for any infringements of intellectual property or other rights of the third parties which may result from its use. No license is granted by implication or otherwise under any intellectual property or other rights of TOSHIBA CORPORATION or others.
- The information contained herein is subject to change without notice.

INTERNAL CIRCUIT

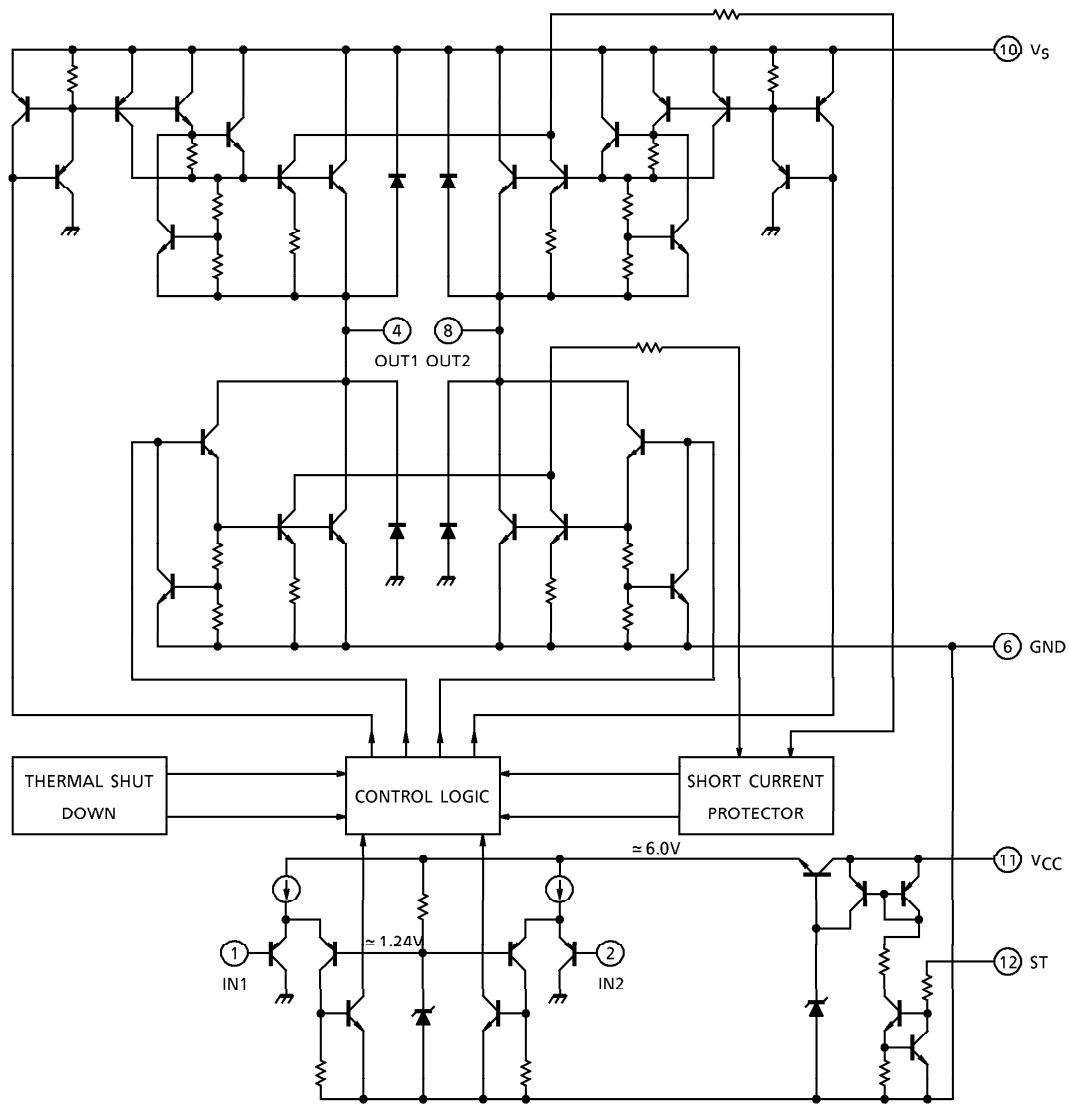

FUNCTION

INPUT			OUTPUT		MODE
IN1	IN2	ST	OUT1	OUT2	MOTOR
H	H	H	L	L	Short brake
L	H	H	L	H	CW / CCW
H	L	H	H	L	CCW / CW
L	L	H	OFF (high impedance)		Stop
H / L	H / L	L	OFF (high impedance)		Stand-by

MAXIMUM RATINGS (Ta = 25°C)

CHARACTERISTIC	SYMBOL	RATING	UNIT
Supply Voltage	V _{CC} , V _S	30	V
Input Voltage	V _{IN}	- 0.3~V _{CC}	V
Output Current	AVE.	I _O (AVE.)	3.0
	PEAK	I _O (PEAK)	4.5 (Note 1)
Power Dissipation	P _D	2.25 (Note 2)	W
		21.6 (Note 3)	
Operating Temperature	T _{opr}	- 30~85	°C
Storage Temperature	T _{stg}	- 55~150	°C

- (Note 1) t = 100ms
- (Note 2) No heat sink
- (Note 3) T_c = 85°C

ELECTRICAL CHARACTERISTICS (V_{CC} = 24V, V_S = 24V, Ta = 25°C)

CHARACTERISTIC	SYMBOL	TEST CIR-CUIT	TEST CONDITION	MIN.	TYP.	MAX.	UNIT
Quiescent Current (I) (V _{CC} Line)	I _{CC1}	1	Stop mode	—	6	12	mA
	I _{CC2}		Forward / reverse mode	—	20	40	
	I _{CC3}		Brake mode	—	20	40	
Quiescent Current (II) (V _S Line)	I _{S1}	1	Stop mode	—	3	8	mA
	I _{S2}		Forward / reverse mode	—	16	40	
	I _{S3}		Brake mode	—	3	8	
Input Voltage	V _{INL}	2	—	—	—	0.8	V
	V _{INH}		—	2.0	—	—	
Input Current	I _{INL}	2	V _{IN} = GND	—	—	12	μA
	I _{INH}		V _{IN} = V _{CC}	—	—	10	
Output Saturation Voltage (Note)	V _{sat1}	3	I _O = 1.5A	—	2.1	2.8	V
	V _{sat2}		I _O = 3.0A	—	3.3	4.1	
Output Leakage Current	I _{LU}	4	V _L = 25V	—	—	50	μA
	I _{LL}		V _L = 25V	—	—	50	
Diode Forward Voltage	V _{FU}	5	I _F = 3.0A	—	5.0	—	V
	V _{FL}		I _F = 3.0A	—	1.5	—	
Limiting Current	I _{SD}	—	—	—	5	—	A
Thermal Shutdown Operating Temperature	T _{SD}	—	—	—	150	—	°C
Stand-by Current	I _{ST}	1	—	—	—	100	μA
Propagation Delay Time	t _{pLH}	2	—	—	1	10	μs
	t _{pHL}	2	—	—	1	10	

(Note) Upper and lower side total

TEST CIRCUIT 1.

I_{S1} , I_{S2} , I_{S3} , I_{CC1} , I_{CC2} , I_{CC3} , I_{ST}

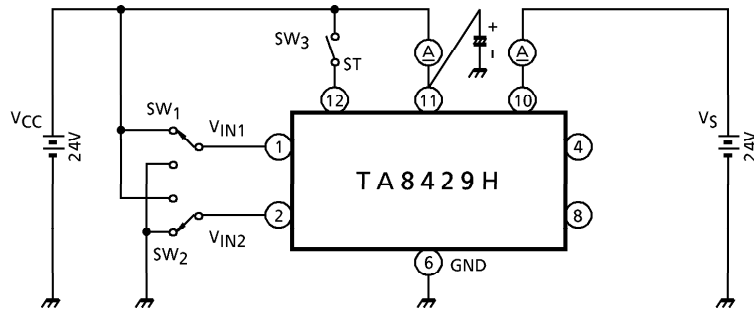

TEST CIRCUIT 2.

V_{INH} , V_{INL} , I_{INH} , I_{INL} , t_{pHL} , t_{pLH}

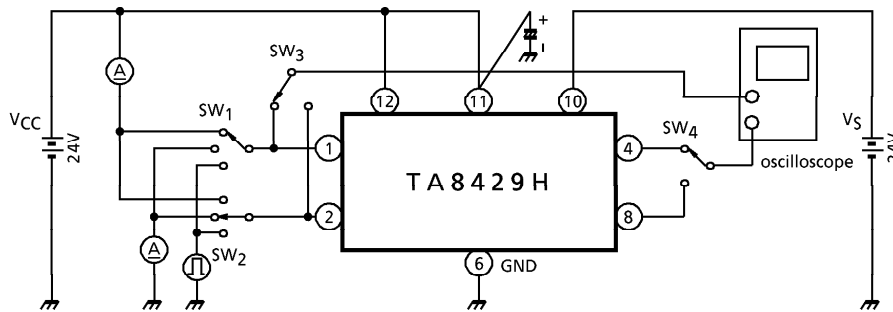

TEST CIRCUIT 3.

V_{sat}

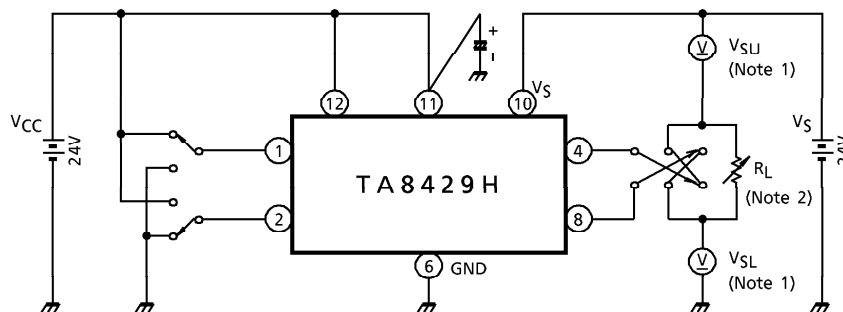

(Note 1) $V_{sat} = V_{SU} + V_{SL}$

(Note 2) Calibrate I_O to 1.5/3.0A by R_L

TEST CIRCUIT 4.

I_{LU} , I_{LL}

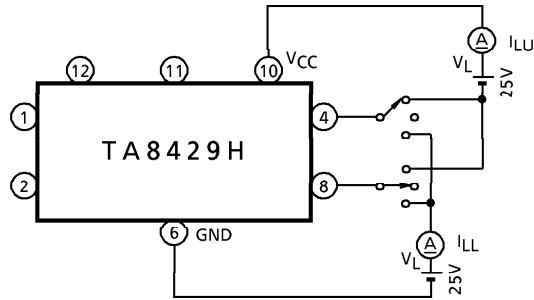

TEST CIRCUIT 5.

V_{FU} , V_{FL}

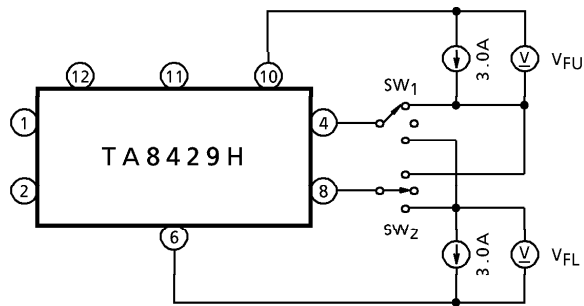

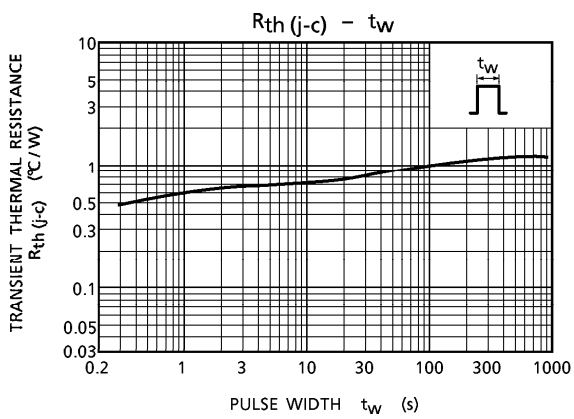
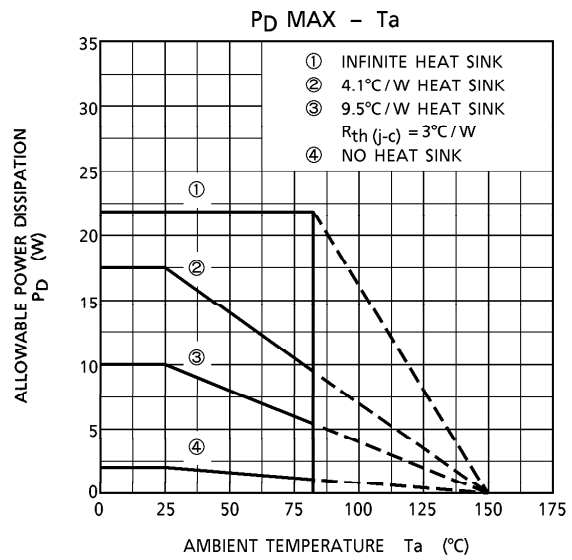
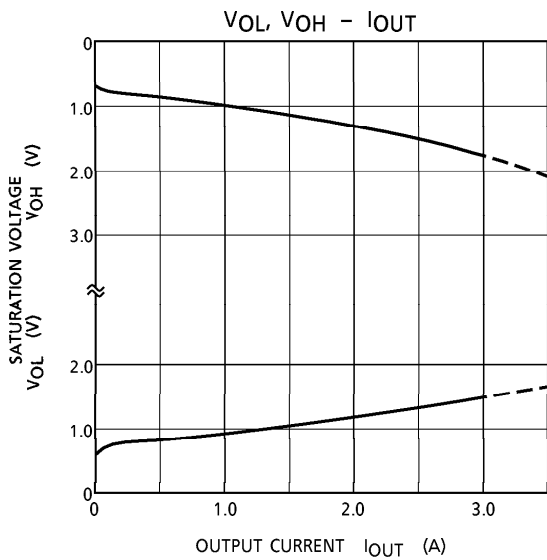

APPLICATION CIRCUIT 1. (Single power supply operation)

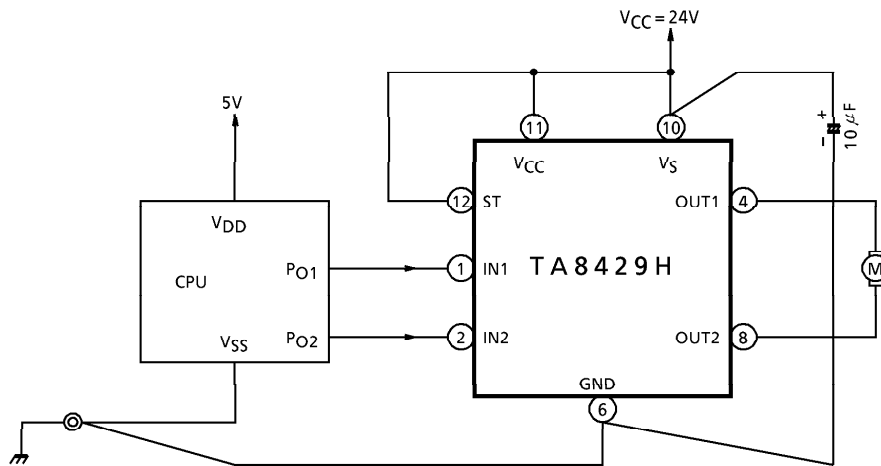

APPLICATION CIRCUIT 2. (Dual power supply (Control and Motor) operation)

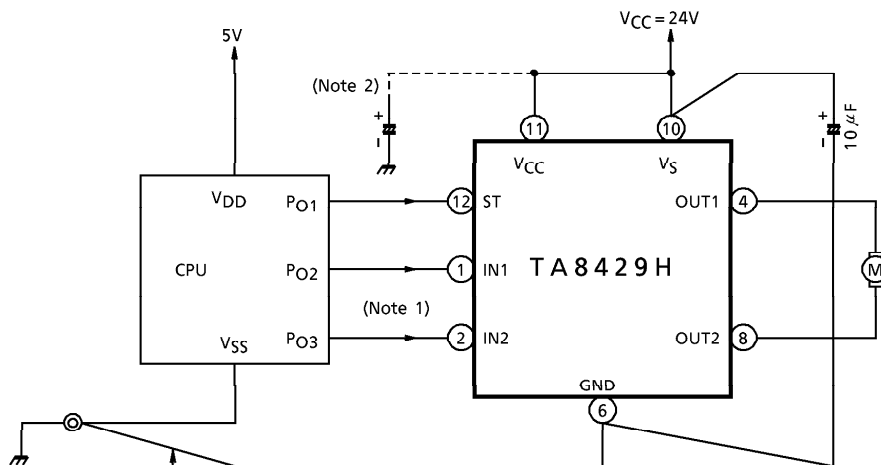

Not to have a common impedance with other lines and use low impedance wire.

- (Note 1) Recommend to take approximately $100\mu s$ of input dead time for reliable operations.
- (Note 2) Connect if required.
- (Note 3) Utmost care is necessary in the design of the output line, V_S and GND line since IC may be destroyed due to short-circuit between outputs, air contamination fault, or fault by improper grounding.

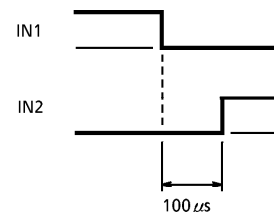

OUTLINE DRAWING
HZIP12-P-1.78B

Unit : mm

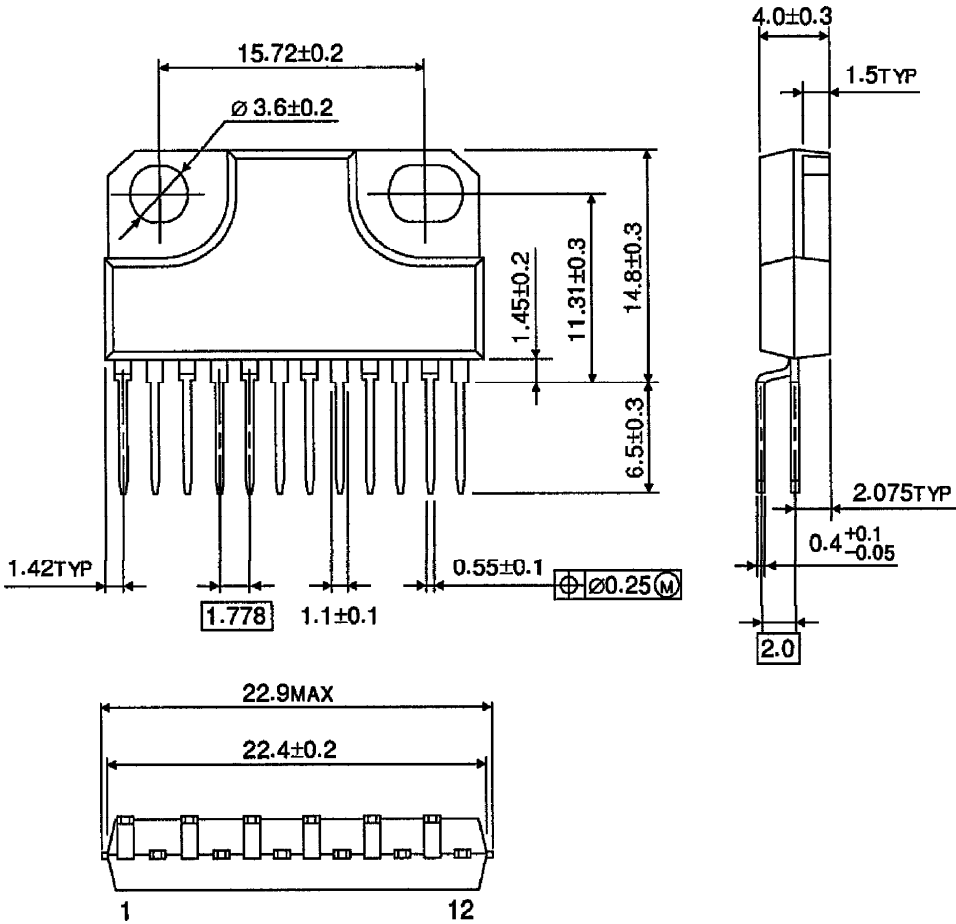

Weight : 4.04g (Typ.)