

TOSHIBA BIPOLAR LINEAR INTEGRATED CIRCUIT SILICON MONOLITHIC

TA8428K(S), TA8428F/FG

FULL BRIDGE DRIVER

The TA8428K (S), TA8428F/FG is Full Bridge Driver IC for Brush Motor Rotation Control.

Forward Rotation, Reverse Rotation, Stop and Braking operations are available.

Thermal Shutdown and Short Current Protector are provided.

FEATURES

- Output Current : TA8428K (S) 1.5 A (AVE.), 3.0 A (PEAK)
TA8428F/FG 0.8 A (AVE.), 2.4 A (PEAK)
- 4 modes (forward / reverse / short brake and stop) are available with 2 TTL compatible inputs control.
- Free wheeling diodes are equipped.
- Multi protection system driver
(Thermal shutdown and short current protector)

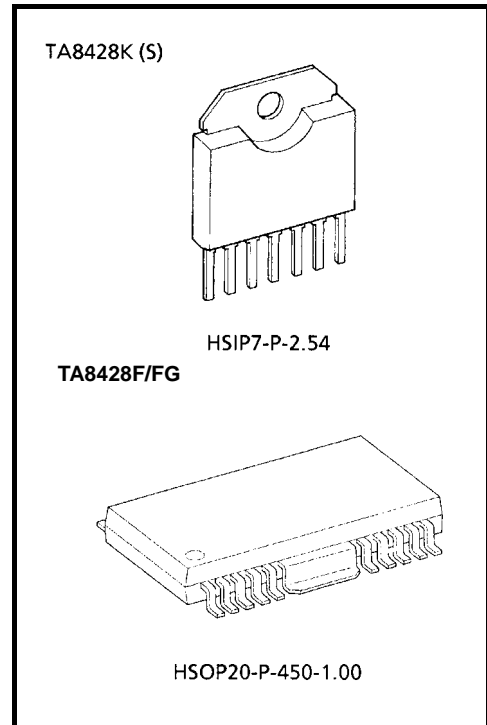

Weight

HSIP7-P-2.54 : 1.88 g (Typ.)

HSOP20-P-450-1.00 : 0.79 g (Typ.)

TA8428K(S), TA8428FG:

TA8428K(S) is Sn plated product including Pb.

TA8428FG is Pb free product.

The following conditions apply to solderability:

*Solderability

1. Use of Sn-37Pb solder bath
 - *solder bath temperature=230 degrees
 - *dipping time=5seconds
 - *number of times=once
 - *use of R-type flux
2. Use of Sn-3.0Ag-0.5Cu solder bath
 - *solder bath temperature=245 degrees
 - *dipping time=5seconds
 - *the number of times=once
 - *use of R-type flux

BLOCK DIAGRAM

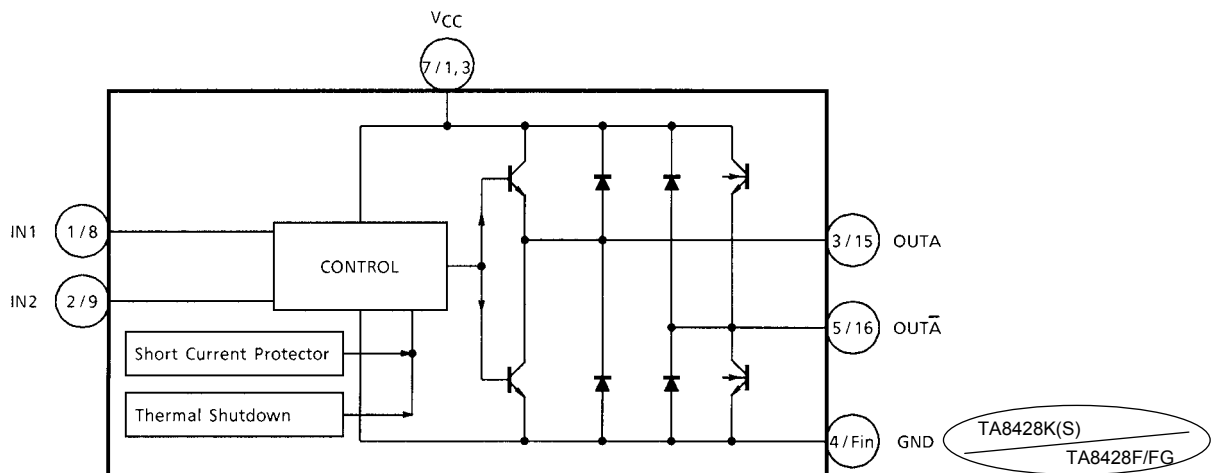

PIN FUNCTION

| PIN No. | | SYMBOL | FUNCTIONAL DESCRIPTION |
|---------|-----------|-----------------|--|
| K(S) | F/FG | | |
| 1 | 8 | IN 1 | TTL compatible control inputs. |
| 2 | 9 | IN 2 | (PNP type low active comparator inputs) |
| 3 | 15 | OUTA | Output terminals and free wheeling diodes are connected between each output to GND and V _{CC} . |
| 4 | Fin | GND | GND terminal |
| 5 | 16 | OUT \bar{A} | Output terminals and free wheeling diodes are connected between each output to GND and V _{CC} . |
| 6 | Other pin | N.C | Non connection |
| 7 | 1, 3 | V _{CC} | Supply voltage terminal for control and motor drive. |

TA8428K (S), TA8428F/FG has 2 build-in protective functions which work independently. These circuit operations are as follows.

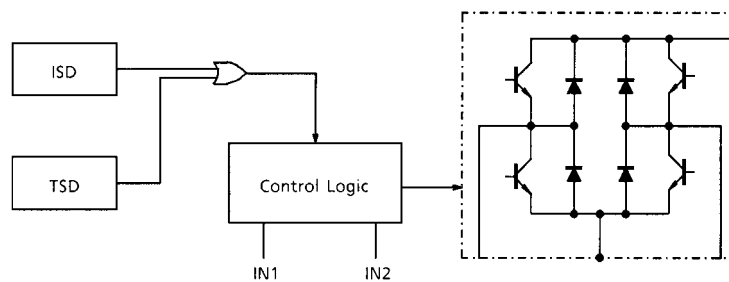

- Thermal shutdown (TSD)

If junction temperature of TA8428K (S), TA8428F/FG is over the specified temperature (150°C Typ.) by excess power dissipation or abnormal ambient temperature change, thermal Shutdown circuit turn "ON" and output 4 transistors become High impedance. (All transistors turn "OFF")

- Short current protector (ISD)

Short current protector circuit senses all output transistor current. If output transistor current is over the specified limiting current value (2.0~3.0 A Typ.), short current protector operates and all output transistors periodically turn "OFF" (High Impedance Mode) in a period of approximately 80 μ s. This state is continued until the release of over current mode.

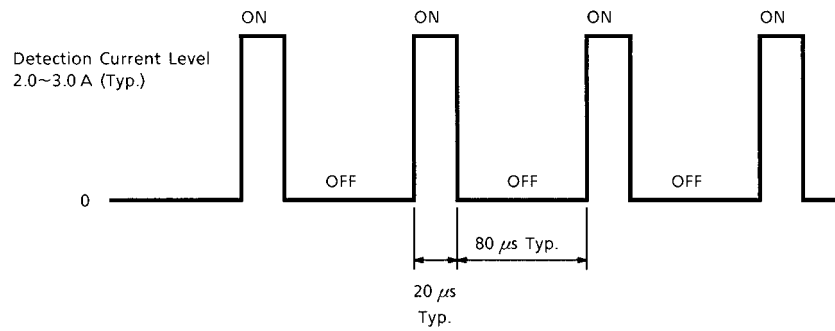

INTERNAL CIRCUIT

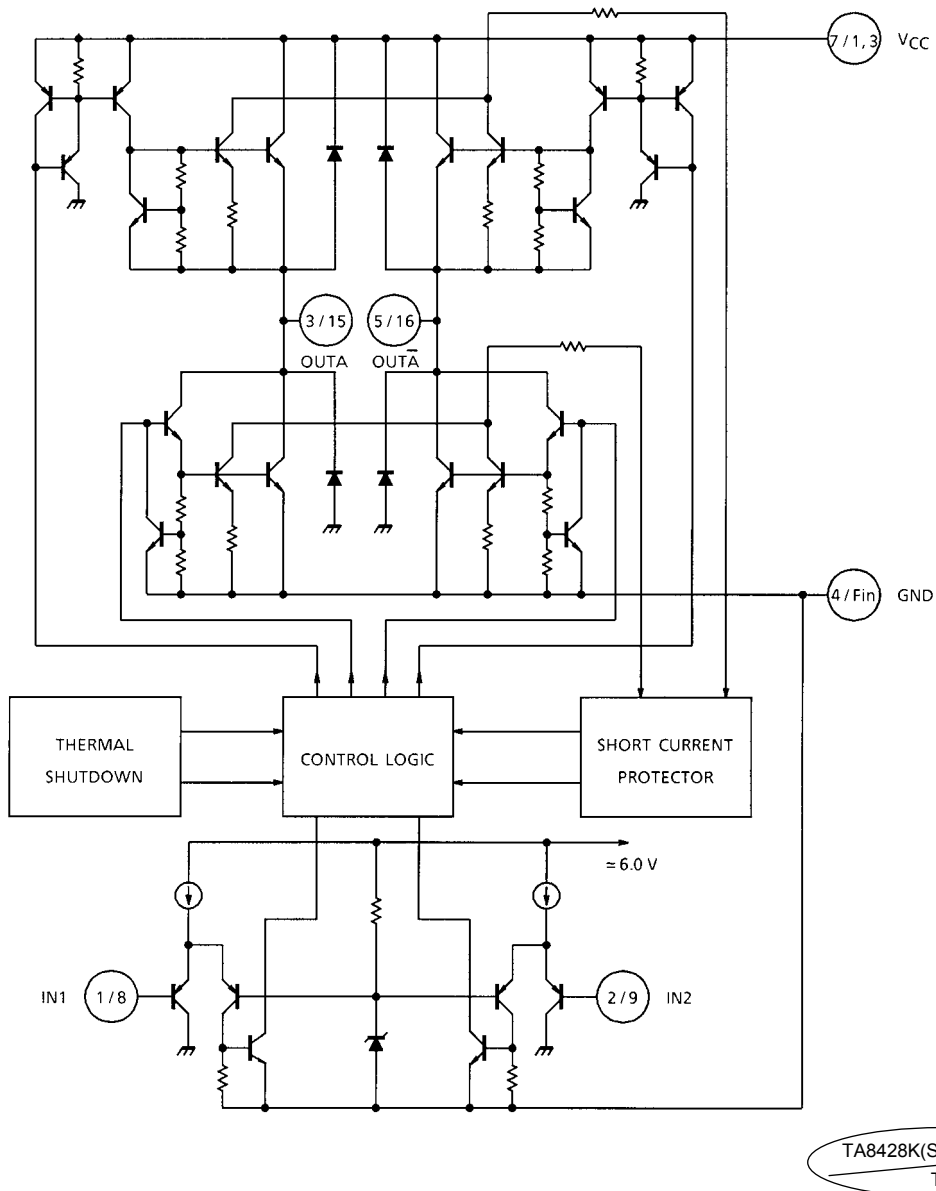

ABSOLUTE MAXIMUM RATINGS (Ta = 25°C)

| CHARACTERISTIC | | SYMBOL | RATING | UNIT |
|-----------------------|------------|------------------|-----------------------|--------------|
| Supply Voltage | | V _{CC} | 30 | V |
| Input Voltage | | V _{IN} | -0.3~V _{CC} | V |
| Output Current | K (S) type | PEAK | I _O (PEAK) | 3.0 (Note 1) |
| | | AVE. | I _O (AVE.) | 1.5 |
| | F/FG type | PEAK | I _O (PEAK) | 2.4 (Note 1) |
| | | AVE. | I _O (AVE.) | 0.8 |
| Power Dissipation | K (S) type | P _D | 1.25 (Note 2) | W |
| | | | 10.0 (Note 3) | |
| | F/FG type | P _D | 1.9 (Note 4) | |
| | | | 2.5 (Note 5) | |
| Operating Temperature | | T _{opr} | -30~85 | °C |
| Storage Temperature | | T _{stg} | -55~150 | °C |

Note 1: t = 100 ms

Note 2: No heat sink

Note 3: T_c = 85°C

Note 4: This value is obtained by 30 × 30 × 1.6 mm PCB mounting occupied copper area in excess of 60%

Note 5: This value is obtained by 50 × 50 × 1.6 mm PCB mounting occupied copper area in excess of 60%

ELECTRICAL CHARACTERISTICS (V_{CC} = 24 V, Ta = 25°C)

| CHARACTERISTIC | | SYMBOL | TEST CIRCUIT | Test Condition | MIN | TYP. | MAX | UNIT |
|--|------------|--------------------------|--------------|---|-----|------|-----|------|
| Quiescent Current | | I _{CC1} | 1 | Stop mode | — | 8 | 15 | mA |
| | | I _{CC2} | | Forward / reverse mode | — | 35 | 85 | |
| | | I _{CC3} | | Brake mode | — | 16 | 30 | |
| Input Voltage | | V _{IL} | 2 | — | — | — | 0.8 | V |
| | | V _{IH} | | — | 2.0 | — | — | |
| Input Current | | I _{IL} | 2 | V _{IN} = GND | — | — | 50 | μA |
| | | I _{IH} | | V _{IN} = V _{CC} | — | — | 10 | |
| Output Saturation Voltage | K (S) type | V _{sat} (total) | 3 | I _O = 1.5 A, T _c = 25°C | — | 2.2 | 2.9 | V |
| | F/FG type | | | I _O = 0.8 A, T _c = 25°C | — | 1.8 | 2.5 | |
| Output Leakage Current | | I _{LU} | 4 | V _L = 25 V | — | — | 50 | μA |
| | | I _{LL} | | | — | — | 50 | |
| Diode Forward Voltage | K (S) type | I _{LU} | 4 | I _F = 1.5 A | — | 2.6 | — | V |
| | | I _{LL} | | | — | 1.5 | — | |
| | F/FG type | I _{LU} | | I _F = 0.8 A | — | 2.2 | — | |
| | | I _{LL} | | | — | 1.2 | — | |
| Thermal Shutdown Circuit Operating Temperature | | T _{SD} | — | — | — | 150 | — | °C |
| Propagation Delay Time | | t _{pLH} | 2 | — | — | 1 | — | μs |
| | | t _{pHL} | 2 | — | — | 1 | — | |

FUNCTION

| INPUT | | OUTPUT | | RATING |
|-------|-----|----------------------|---------------|----------|
| IN1 | IN2 | OUTA | OUT \bar{A} | |
| H | H | L | L | Brake |
| L | H | L | H | CW / CCW |
| H | L | H | L | CCW / CW |
| L | L | OFF (high impedance) | | Stop |

Note: PIN (6) is non connection.

Note: Heat fin is connected with GND with low impedance.

TEST CIRCUIT 1

I_{CC1} , I_{CC2} , I_{CC3}

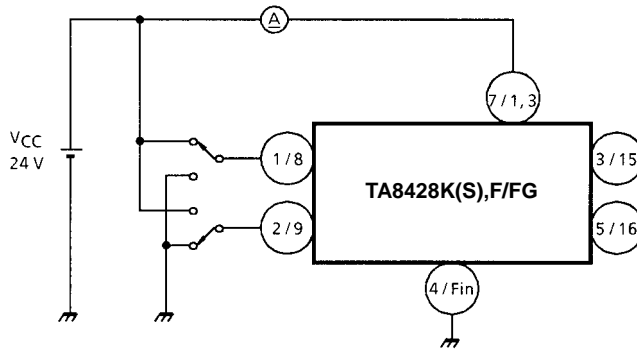

TEST CIRCUIT 2

V_{IL} , V_{IH} , I_{IL} , I_{IH} , t_{pLH} , t_{pHL}

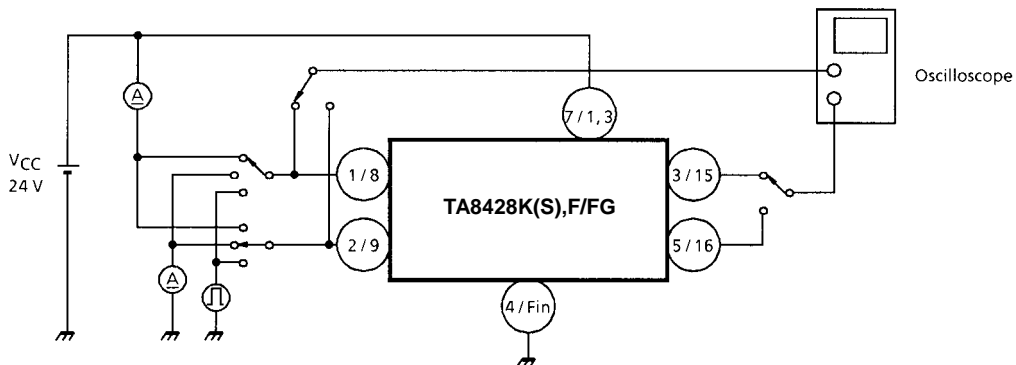

TEST CIRCUIT 3

V_{sat}

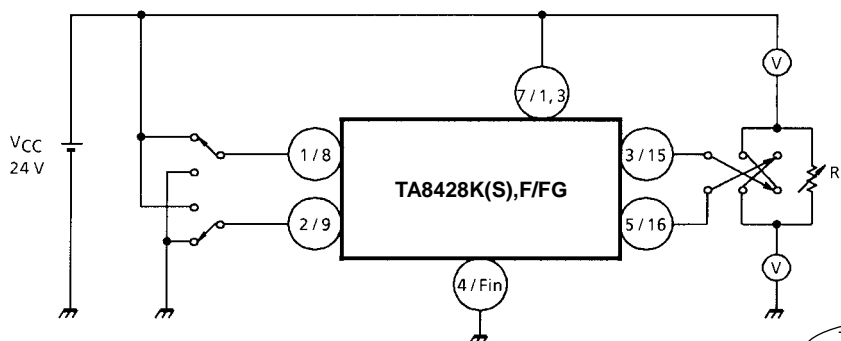

TA8428K(S)
TA8428F/FG

TEST CIRCUIT 4

I_{LH} , I_{LL}

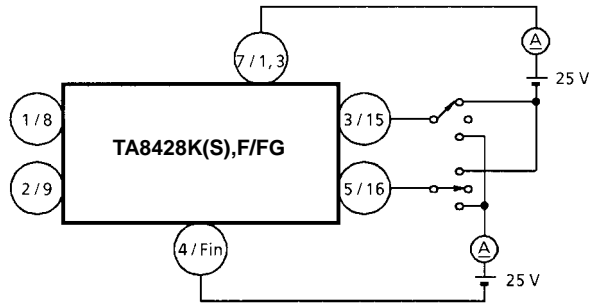

TEST CIRCUIT 5

V_{FU} , V_{FL}

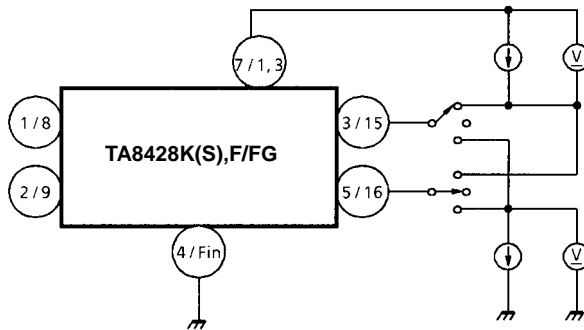

TA8428K(S)
TA8428F/FG

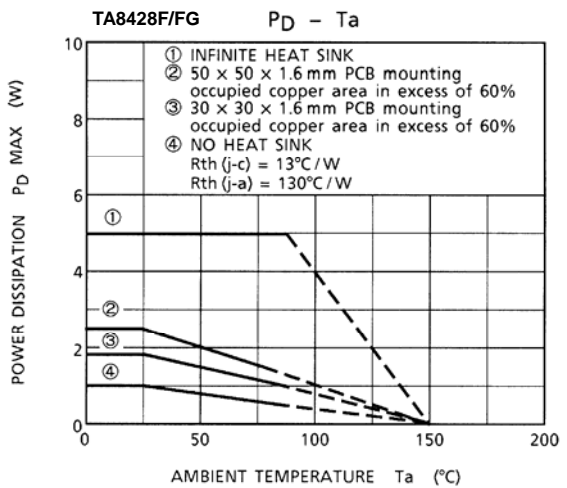
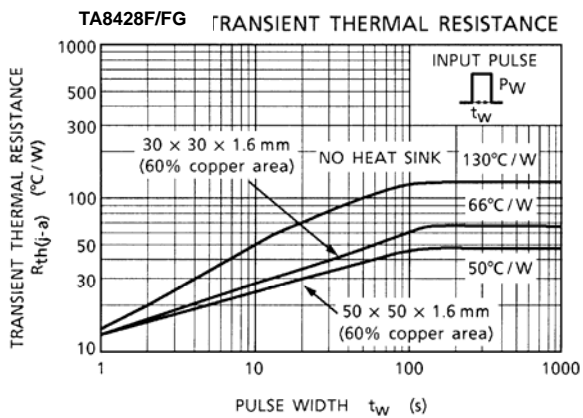
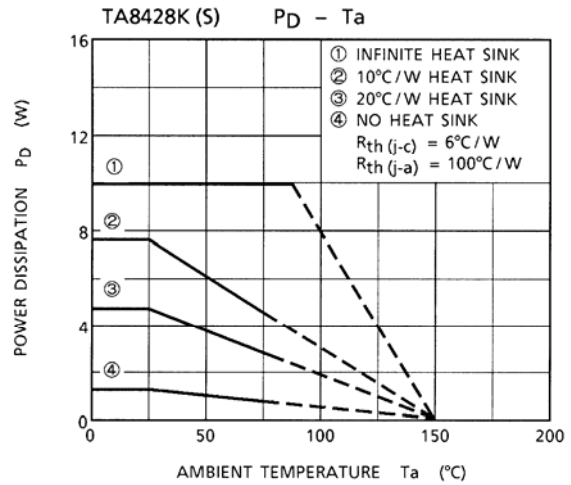
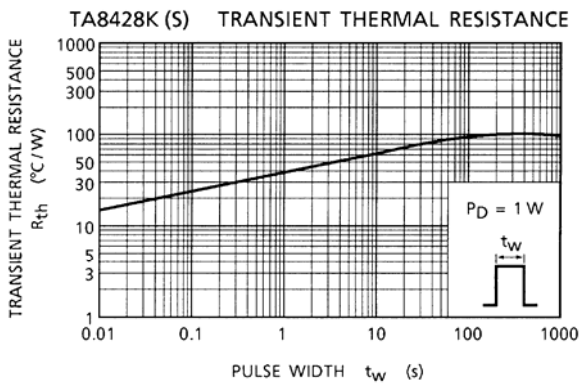
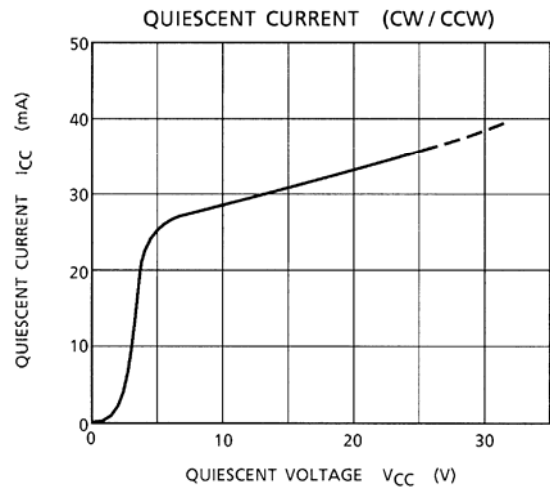
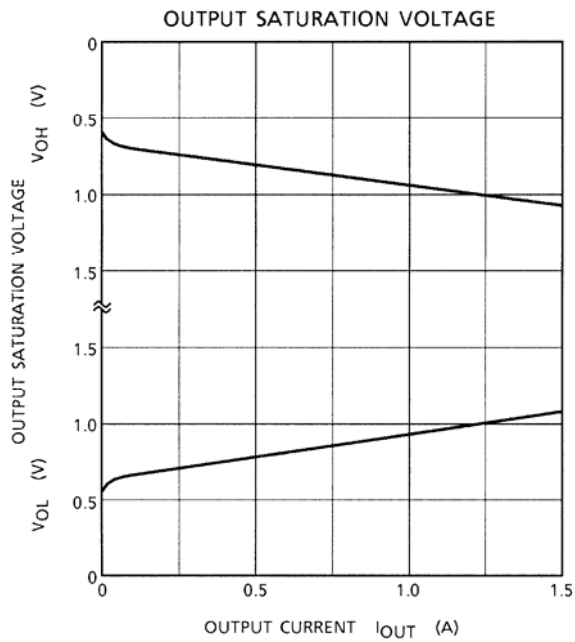

APPLICATION CIRCUIT

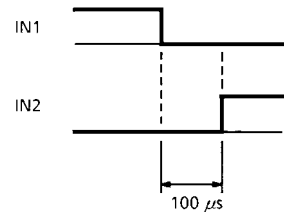
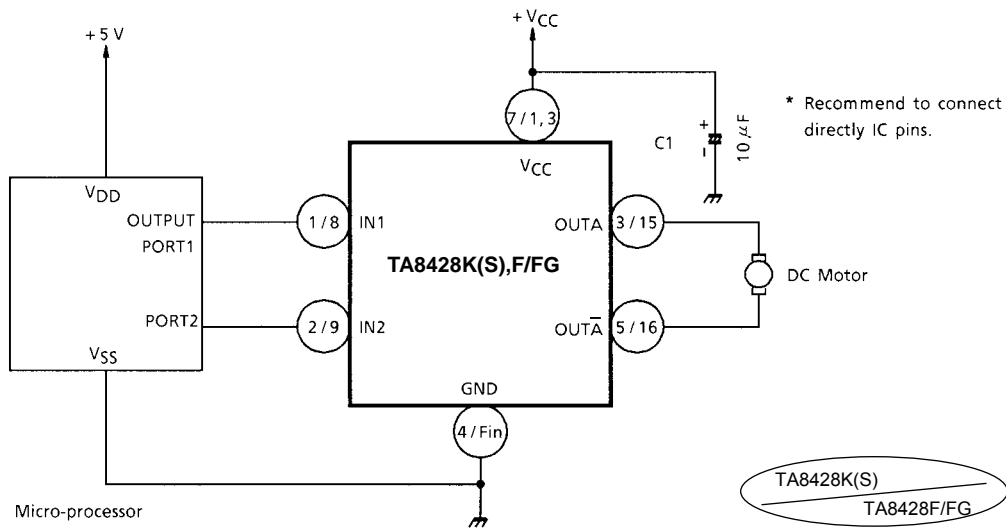

Note: Recommend to take approximately 100 μs of input dead time for reliable operations.

Note: Utmost care is necessary in the design of the output, V_{CC} , V_M , and GND lines since the IC may be destroyed by short-circuiting between outputs, air contamination faults, or faults due to improper grounding, or by short-circuiting between contiguous pins.

Note: In case of mounted on radiators, do not use silicon rubber. (TA8428K (S))

Note: Connect and use 1 pin and 3 pin surely. (TA8428F/FG)

PACKAGE DIMENSIONS

HSIP7-P-2.54

Unit : mm

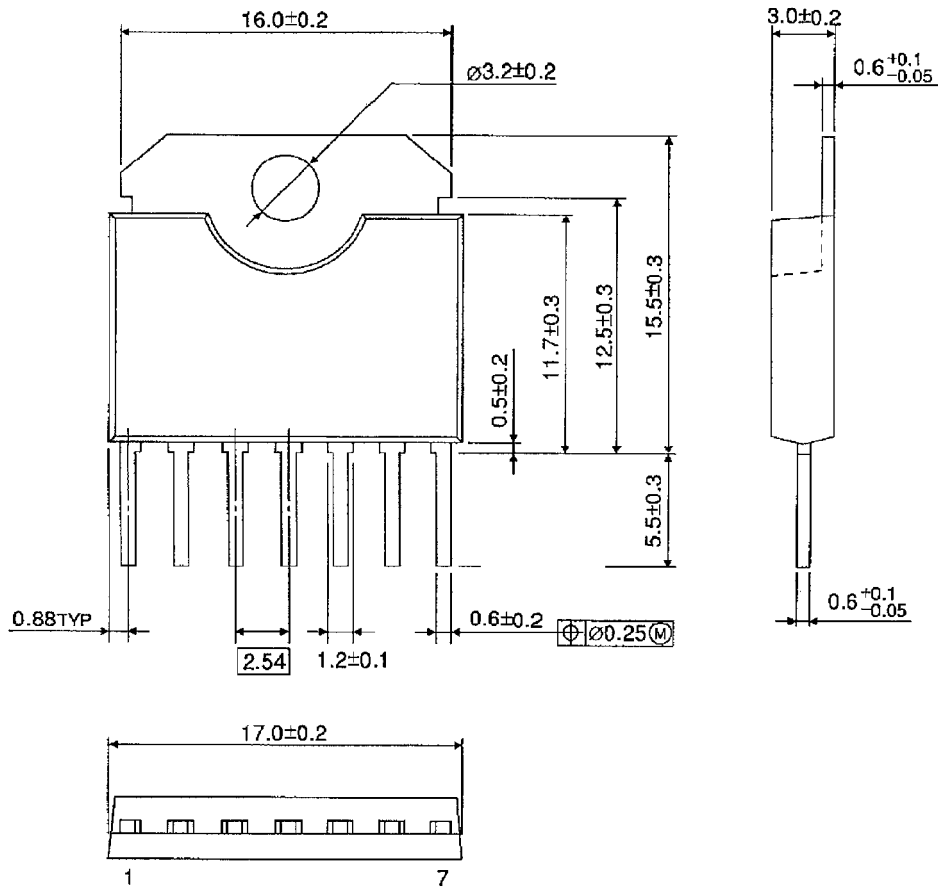

Weight : 1.88 g (Typ.)

PACKAGE DIMENSIONS

HSOP20-P-450-1.00

Unit : mm

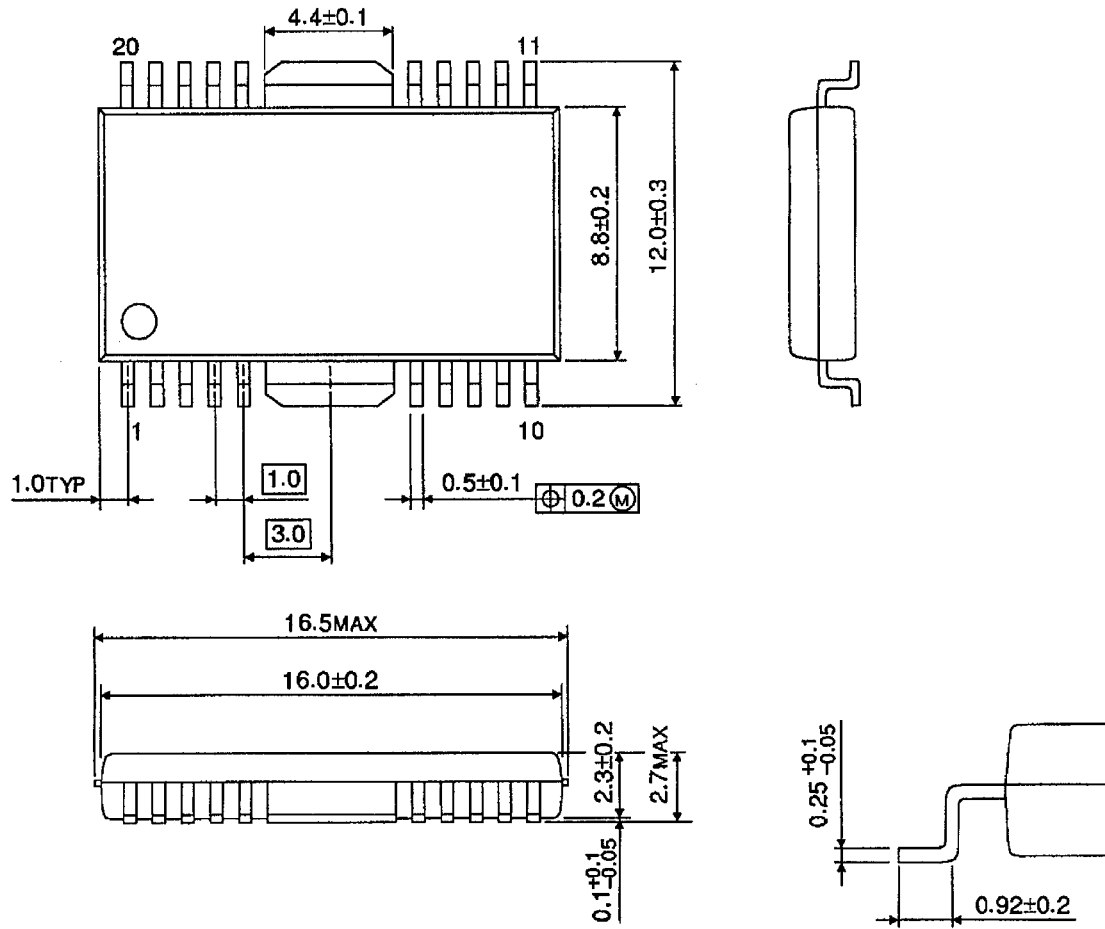

Weight : 0.79 g (Typ.)

Notes on Contents

1. Block Diagrams

Some of the functional blocks, circuits, or constants in the block diagram may be omitted or simplified for explanatory purposes.

2. Equivalent Circuits

The equivalent circuit diagrams may be simplified or some parts of them may be omitted for explanatory purposes.

3. Timing Charts

Timing charts may be simplified for explanatory purposes.

4. Application Circuits

The application circuits shown in this document are provided for reference purposes only. Thorough evaluation is required, especially at the mass production design stage.

Toshiba does not grant any license to any industrial property rights by providing these examples of application circuits.

5. Test Circuits

Components in the test circuits are used only to obtain and confirm the device characteristics. These components and circuits are not guaranteed to prevent malfunction or failure from occurring in the application equipment.

IC Usage Considerations

Notes on handling of ICs

- [1] The absolute maximum ratings of a semiconductor device are a set of ratings that must not be exceeded, even for a moment. Do not exceed any of these ratings.
Exceeding the rating(s) may cause the device breakdown, damage or deterioration, and may result injury by explosion or combustion.
- [2] Use an appropriate power supply fuse to ensure that a large current does not continuously flow in case of over current and/or IC failure. The IC will fully break down when used under conditions that exceed its absolute maximum ratings, when the wiring is routed improperly or when an abnormal pulse noise occurs from the wiring or load, causing a large current to continuously flow and the breakdown can lead smoke or ignition. To minimize the effects of the flow of a large current in case of breakdown, appropriate settings, such as fuse capacity, fusing time and insertion circuit location, are required.
- [3] If your design includes an inductive load such as a motor coil, incorporate a protection circuit into the design to prevent device malfunction or breakdown caused by the current resulting from the inrush current at power ON or the negative current resulting from the back electromotive force at power OFF. IC breakdown may cause injury, smoke or ignition.
Use a stable power supply with ICs with built-in protection functions. If the power supply is unstable, the protection function may not operate, causing IC breakdown. IC breakdown may cause injury, smoke or ignition.
- [4] Do not insert devices in the wrong orientation or incorrectly.
Make sure that the positive and negative terminals of power supplies are connected properly.
Otherwise, the current or power consumption may exceed the absolute maximum rating, and exceeding the rating(s) may cause the device breakdown, damage or deterioration, and may result injury by explosion or combustion.
In addition, do not use any device that is applied the current with inserting in the wrong orientation or incorrectly even just one time.

Points to remember on handling of ICs**(1) Over current Protection Circuit**

Over current protection circuits (referred to as current limiter circuits) do not necessarily protect ICs under all circumstances. If the Over current protection circuits operate against the over current, clear the over current status immediately.

Depending on the method of use and usage conditions, such as exceeding absolute maximum ratings can cause the over current protection circuit to not operate properly or IC breakdown before operation. In addition, depending on the method of use and usage conditions, if over current continues to flow for a long time after operation, the IC may generate heat resulting in breakdown.

(2) Thermal Shutdown Circuit

Thermal shutdown circuits do not necessarily protect ICs under all circumstances. If the thermal shutdown circuits operate against the over temperature, clear the heat generation status immediately.

Depending on the method of use and usage conditions, such as exceeding absolute maximum ratings can cause the thermal shutdown circuit to not operate properly or IC breakdown before operation.

(3) Heat Radiation Design

In using an IC with large current flow such as power amp, regulator or driver, please design the device so that heat is appropriately radiated, not to exceed the specified junction temperature (T_j) at any time and condition. These ICs generate heat even during normal use. An inadequate IC heat radiation design can lead to decrease in IC life, deterioration of IC characteristics or IC breakdown. In addition, please design the device taking into consideration the effect of IC heat radiation with peripheral components.

(4) Back-EMF

When a motor rotates in the reverse direction, stops or slows down abruptly, a current flow back to the motor's power supply due to the effect of back-EMF. If the current sink capability of the power supply is small, the device's motor power supply and output pins might be exposed to conditions beyond maximum ratings. To avoid this problem, take the effect of back-EMF into consideration in system design.

RESTRICTIONS ON PRODUCT USE

070122EBA_R6

- The information contained herein is subject to change without notice. 021023_D
- TOSHIBA is continually working to improve the quality and reliability of its products. Nevertheless, semiconductor devices in general can malfunction or fail due to their inherent electrical sensitivity and vulnerability to physical stress. It is the responsibility of the buyer, when utilizing TOSHIBA products, to comply with the standards of safety in making a safe design for the entire system, and to avoid situations in which a malfunction or failure of such TOSHIBA products could cause loss of human life, bodily injury or damage to property.
In developing your designs, please ensure that TOSHIBA products are used within specified operating ranges as set forth in the most recent TOSHIBA products specifications. Also, please keep in mind the precautions and conditions set forth in the "Handling Guide for Semiconductor Devices," or "TOSHIBA Semiconductor Reliability Handbook" etc. 021023_A
- The TOSHIBA products listed in this document are intended for usage in general electronics applications (computer, personal equipment, office equipment, measuring equipment, industrial robotics, domestic appliances, etc.). These TOSHIBA products are neither intended nor warranted for usage in equipment that requires extraordinarily high quality and/or reliability or a malfunction or failure of which may cause loss of human life or bodily injury ("Unintended Usage"). Unintended Usage include atomic energy control instruments, airplane or spaceship instruments, transportation instruments, traffic signal instruments, combustion control instruments, medical instruments, all types of safety devices, etc. Unintended Usage of TOSHIBA products listed in this document shall be made at the customer's own risk. 021023_B
- The products described in this document shall not be used or embedded to any downstream products of which manufacture, use and/or sale are prohibited under any applicable laws and regulations. 060106_Q
- The information contained herein is presented only as a guide for the applications of our products. No responsibility is assumed by TOSHIBA for any infringements of patents or other rights of the third parties which may result from its use. No license is granted by implication or otherwise under any patents or other rights of TOSHIBA or the third parties. 070122_C
- Please use this product in compliance with all applicable laws and regulations that regulate the inclusion or use of controlled substances.
Toshiba assumes no liability for damage or losses occurring as a result of noncompliance with applicable laws and regulations. 060819_AF
- The products described in this document are subject to foreign exchange and foreign trade control laws. 060925_E