

TOSHIBA BIPOLAR LINEAR INTEGRATED CIRCUIT SILICON MONOLITHIC

TA8409S, TA8409F

BRIDGE DRIVER

TA8409S and TA8409F are bridge driver with output voltage control.

FEATURES

- Modes available (CW/CCW/STOP/BRAKE)
- Output current up to 0.4 A (AVE) and 1.0 A (PEAK)
- Wide range of operating voltage
 $V_{CC} \text{ (opr.)} = 4.5 \sim 20 \text{ V}$
 $V_S \text{ (opr.)} = 0 \sim 20 \text{ V}$
 $V_{ref} \text{ (opr.)} = 0 \sim 20 \text{ V} \text{ (} V_{ref} \leq V_S \text{)}$
- Built-in thermal shutdown
- Standby mode available (STOP MODE)
- Hysteresis for all inputs

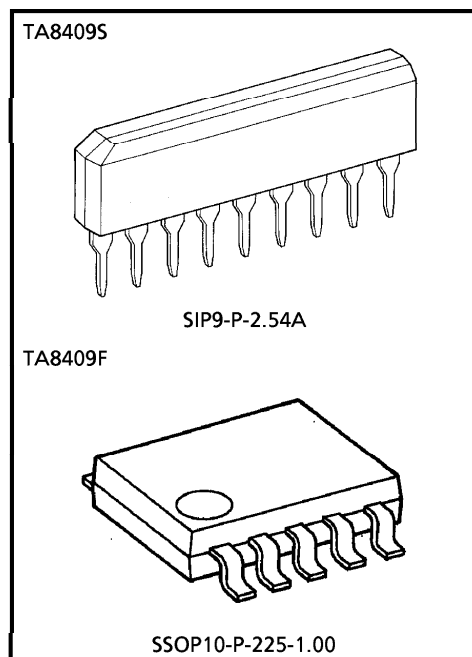

BLOCK DIAGRAM

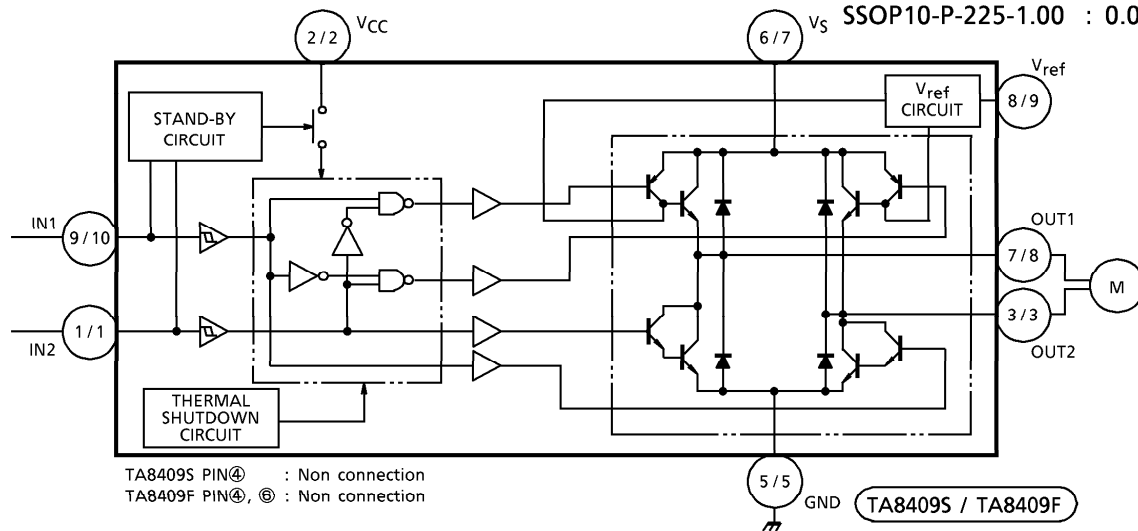

Weight
 SIP9-P-2.54A : 0.92 g (Typ.)
 SSOP10-P-225-1.00 : 0.09 g (Typ.)

980910EBA2

- TOSHIBA is continually working to improve the quality and the reliability of its products. Nevertheless, semiconductor devices in general can malfunction or fail due to their inherent electrical sensitivity and vulnerability to physical stress. It is the responsibility of the buyer, when utilizing TOSHIBA products, to observe standards of safety, and to avoid situations in which a malfunction or failure of a TOSHIBA product could cause loss of human life, bodily injury or damage to property. In developing your designs, please ensure that TOSHIBA products are used within specified operating ranges as set forth in the most recent products specifications. Also, please keep in mind the precautions and conditions set forth in the TOSHIBA Semiconductor Reliability Handbook.
- The products described in this document are subject to the foreign exchange and foreign trade laws.
- The information contained herein is presented only as a guide for the applications of our products. No responsibility is assumed by TOSHIBA CORPORATION for any infringements of intellectual property or other rights of the third parties which may result from its use. No license is granted by implication or otherwise under any intellectual property or other rights of TOSHIBA CORPORATION or others.
- The information contained herein is subject to change without notice.

PIN FUNCTION
 TA8409S

PIN No.	SYMBOL	FUNCTIONAL DESCRIPTION
1	IN2	Input terminal
2	V _{CC}	Supply voltage terminal for logic
3	OUT2	Output terminal
4	NC	Non connection
5	GND	GND terminal
6	V _S	Supply voltage terminal for motor driver
7	OUT1	Output terminal
8	V _{ref}	Reference voltage terminal for control circuit
9	IN1	Input terminal

TA8409F

PIN No.	SYMBOL	FUNCTIONAL DESCRIPTION
1	IN2	Input terminal
2	V _{CC}	Supply voltage terminal for logic
3	OUT2	Output terminal
4	NC	Non connection
5	GND	GND terminal
6	NC	Non connection
7	V _S	Supply voltage terminal for motor driver
8	OUT1	Output terminal
9	V _{ref}	Reference voltage terminal for control circuit.
10	IN1	Input terminal

FUNCTION

INPUT		OUTPUT		MODE
IN1	IN2	OUT1	OUT2	MOTOR
0	0	∞	∞	STOP
1	0	H	L	CW / CCW
0	1	L	H	CCW / CW
1	1	L	L	BRAKE

(∞) High impedance

(Note) Inputs are all high active type.

MAXIMUM RATINGS (Ta = 25°C)

CHARACTERISTIC	SYMBOL	RATING	UNIT
Supply Voltage	V _{CC}	25	V
Motor Drive Voltage	V _S	25	V
Reference Voltage	V _{ref}	25	V
Output Current	PEAK	I _O (PEAK)	1.0
	AVE	I _O (AVE.)	0.4
Power Dissipation	TA8409F	P _D	0.735 (Note)
	TA8409S		0.95
Operating Temperature	T _{opr}	-30~75	°C
Storage Temperature	T _{stg}	-55~150	°C

(Note) This rating is obtained by mounting on 50 × 50 × 1.6 mm PCB that occupied above 30% of copper area.

ELECTRICAL CHARACTERISTICS (Ta = 25°C, V_{CC} = 12 V, V_S = 18 V)

CHARACTERISTIC	SYMBOL	TEST CIR-CUIT	TEST CONDITION	MIN.	TYP.	MAX.	UNIT	
Supply Current	I _{CC1}	1	Output OFF, CW / CCW mode	—	10.0	15.0	mA	
	I _{CC2}	1	Output OFF, STOP mode	—	0	50	μA	
	I _{CC3}	1	Output OFF, BREAK mode	—	6.5	10.0	mA	
Input Operating Voltage	1 (High)	V _{IN1}	2	T _j = 25°C IN1, 2	3.5	—	5.5	V
	1 (Low)	V _{IN2}	2	T _j = 25°C IN1, 2	GND	—	0.8	
Input Current	I _{IN}	2	Sink mode, V _{IN} = 3.5 V	—	3	10	μA	
Input Hysteresis Voltage	ΔV _T	2	—	—	0.7	—	V	
Saturation Voltage	Upper Side	V _{SAT U-1}	3	V _{ref} = V _S , V _{OUT} -V _S measure I _O = 0.2 A, CW / CCW mode	—	0.9	1.2	V
	Lower Side	V _{SAT L-1}	3	V _{ref} = V _S , V _{OUT} -GND measure I _O = 0.2 A, CW / CCW mode	—	0.8	1.2	
	Upper Side	V _{SAT U-2}	3	V _{ref} = V _S , V _{OUT} -V _S measure I _O = 0.4 A, CW / CCW mode	—	1.0	1.35	
	Lower Side	V _{SAT L-2}	3	V _{ref} = V _S , V _{OUT} -GND measure I _O = 0.4 A, CW / CCW mode	—	0.9	1.35	
Output Voltage	V _{SAT U-1'}	3	V _{ref} = 10 V, V _{OUT} -GND measure I _O = 0.2 A	10.4	11.2	12.2	V	
	V _{SAT U-2'}	3	V _{ref} = 10 V, V _{OUT} -GND measure I _O = 0.4 A	—	10.9	—		
Output Transistor Leakage Current	Upper Side	I _{LU}	4	V _L = 25 V	—	—	50	μA
	Lower Side	I _{LL}	4	V _L = 25 V	—	—	50	
Diode Forward Voltage	Upper Side	V _{F U-1}	5	I _F = 0.4 A	—	1.5	—	V
	Lower Side	V _{F L-1}	5	I _F = 0.4 A	—	0.9	—	
Reference Current	I _{ref}	2	V _{ref} = 10 V, source mode	—	20	40	μA	

TEST CIRCUIT 3

V_{SAT} U-1, 2, V_{SAT} L-1, 2, V_{SAT} U-1', 2'

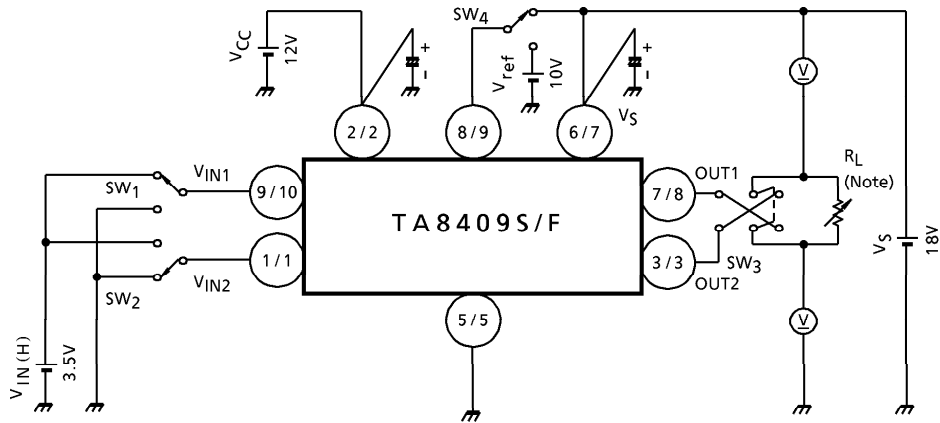

(Note) Calibrate I_{OUT} to 0.2/0.4 A by R_L .

TEST CIRCUIT 4

I_L U, L

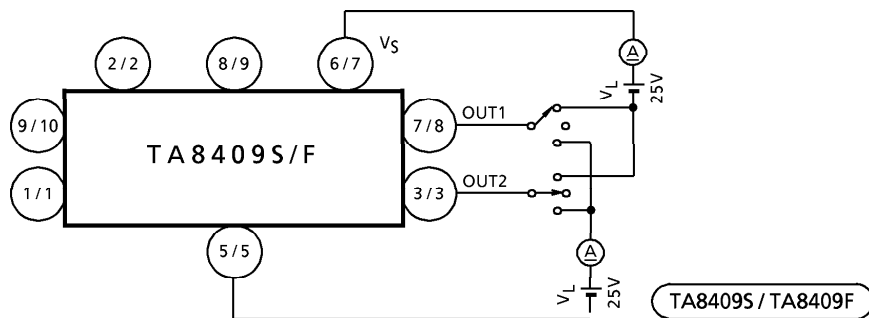

TEST CIRCUIT 5

V_F U-1, 2, V_F L-1, 2

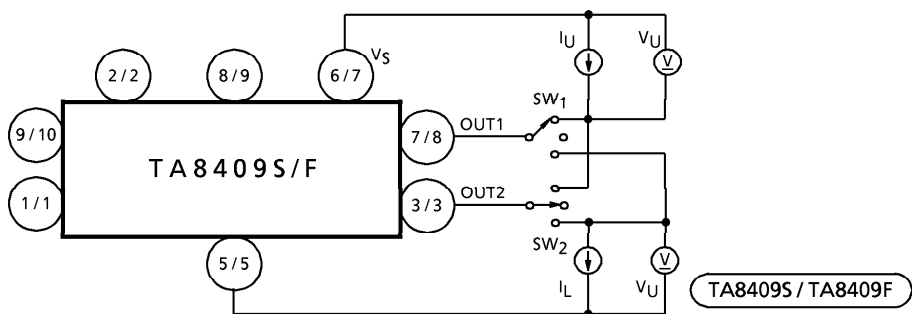

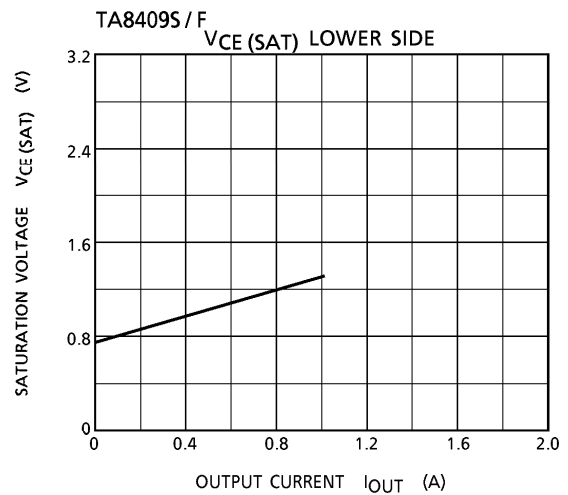
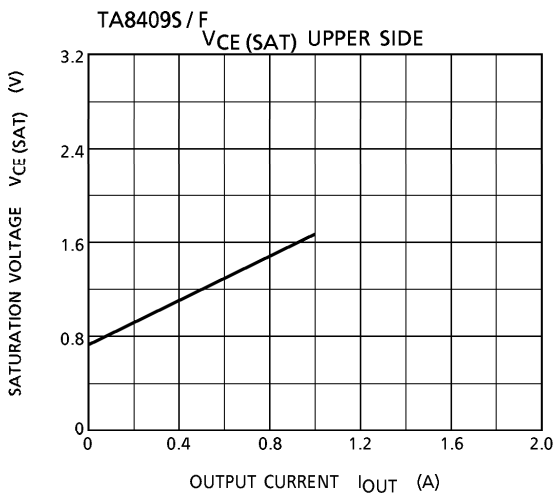
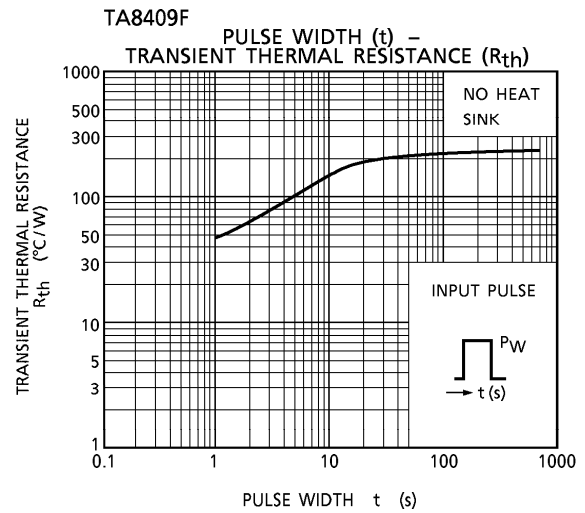
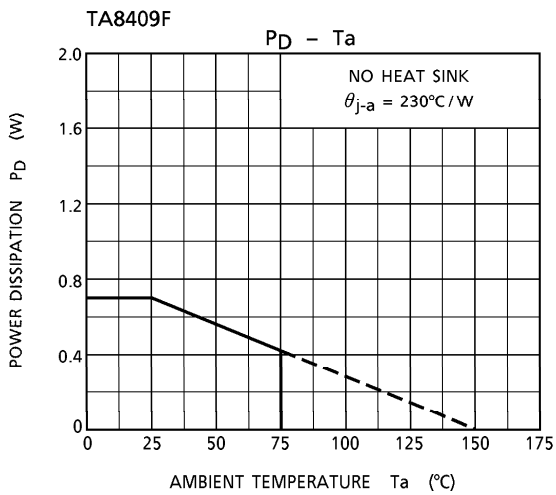
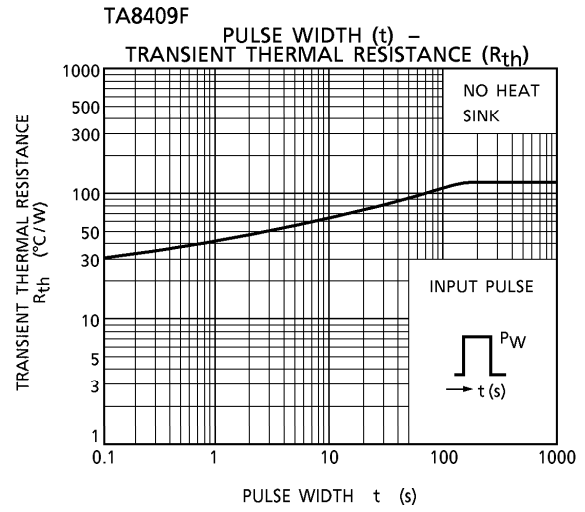
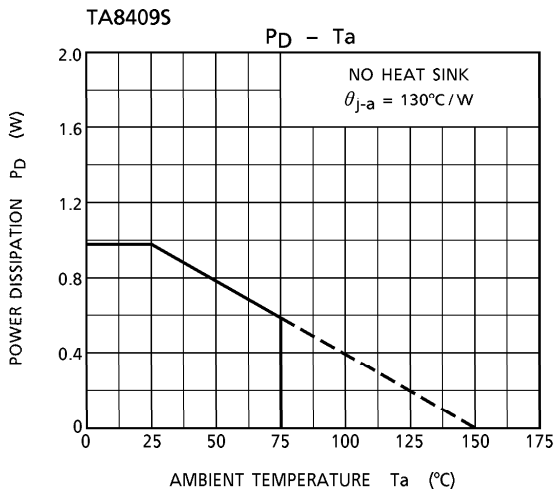

APPLICATION CIRCUIT

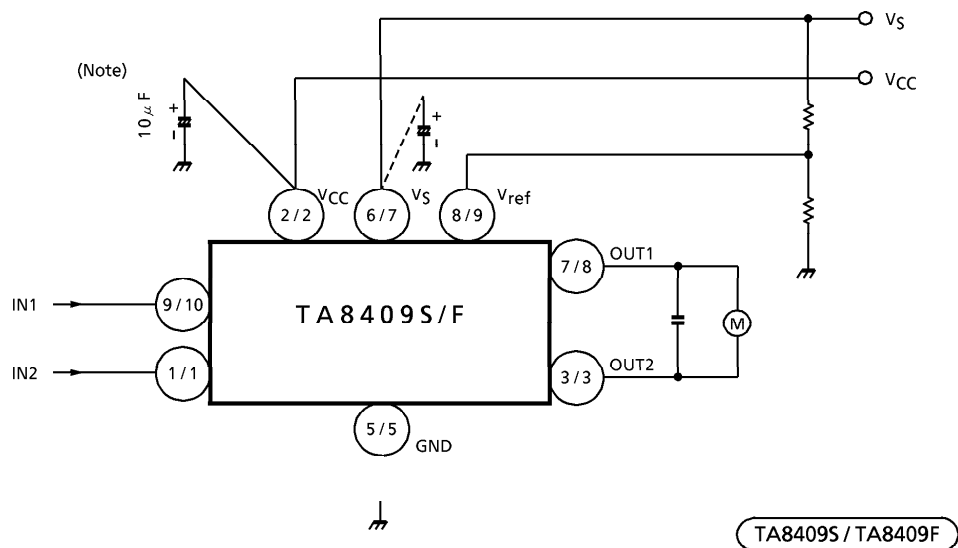

- (Note 1) Connect if required.
- (Note 2) Utmost care is necessary in the design of the output line, V_S and GND line since IC may be destroyed due to short-circuit between outputs, air contamination fault, or fault by improper grounding.
- (Note 3) Be careful when switching the input because rush current may occur. When switching, stop mode should be entered or current limitation resistor R should be inserted.
- (Note 4) The IC functions cannot be guaranteed when turning power on or off. Before using the IC for application, check that there are no problems.

OUTLINE DRAWING
SIP9-P-2.54A

Unit : mm

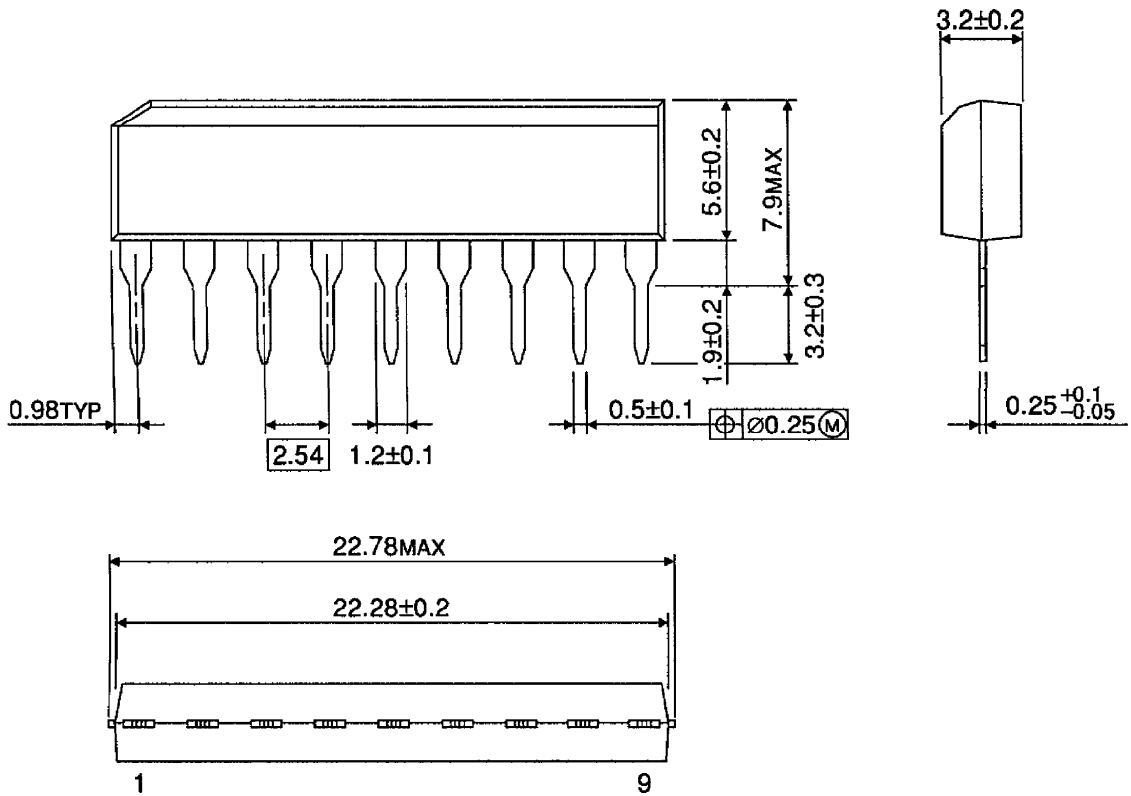

Weight : 0.92 g (Typ.)

OUTLINE DRAWING
SSOP10-P-225-1.00

Unit : mm

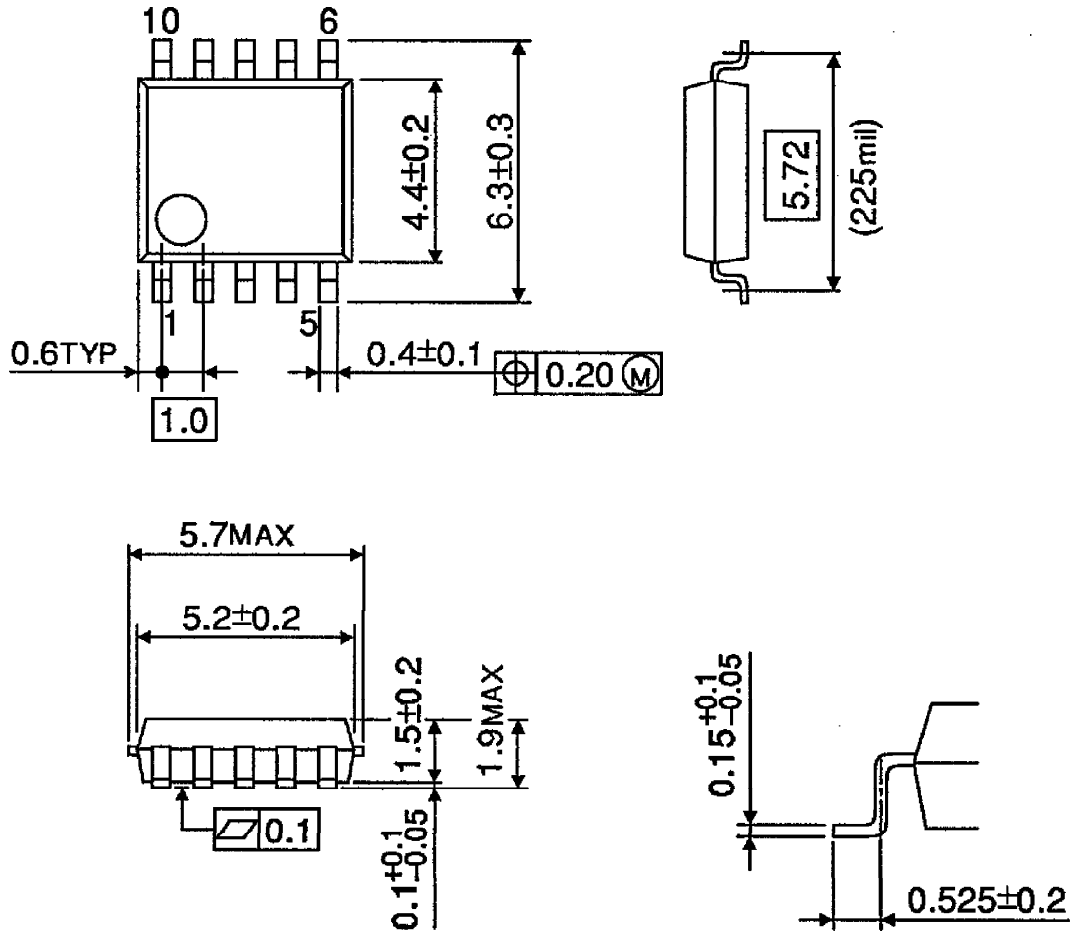

Weight : 0.09 g (Typ.)