

Preliminary TOSHIBA Bipolar Linear Integrated Circuit Silicon Monolithic

TA84007PQ, TA84007SG, TA84007FG

DC Motor Full Bridge Driver ICs (Forward/reverse switching driver ICs)

The TA84007PQ, TA84007SG and TA84007FG are bridge driver ICs designed for forward/reverse rotation switching and that are capable of four modes of control (forward, reverse, stop and brake).

The TA84007PQ has an output current of 1.0 A (AVE.) and 2.0 A (PEAK) and the TA84007SG and TA84007FG have an output current of 0.4 A (AVE.) and 1.2 A (PEAK).

These driver ICs are equipped with a dual power supply pin on the output and control sides and a V_{ref} pin on the output side capable of controlling motor voltage making it possible to adjust the voltage applied to the motor. Additionally, these driver ICs have a low input current and can connect directly to the CMOS.

Features

- Operation power supply voltage range:
 V_{CC} (opr.) = 4.5 to 27 V
 V_S (opr.) = 4.5 to 27 V
 V_{ref} (opr.) = 4.5 to 27 V
 Usage Note:
 Design your application so that $V_{ref} \leq V_S$
- Output current: PQ: 1.0 A (AVE.), 2.0 A (PEAK)
 SG and FG: 0.4 A (AVE.), 1.2 A (PEAK)
- Built-in thermal shutdown and overcurrent protection
- Built-in back EMF suppression diode
- Built-in input hysteresis
- Built-in standby

Note: These ICs are highly sensitive to electrostatic discharge. When handling them, please be careful of electrostatic discharge, temperature and humidity conditions.

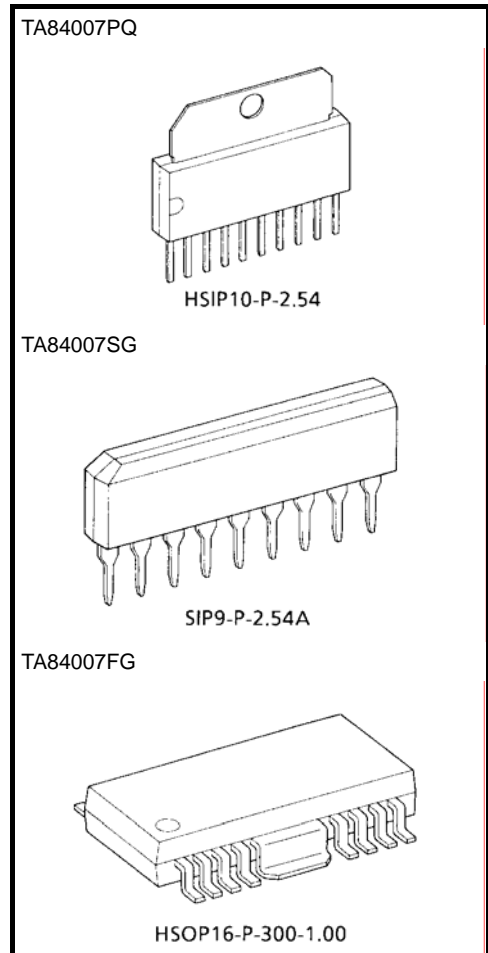

Weight
 HSIP10-P-2.54: 2.47 g (typ.)
 SOIP9-P-2.54A: 0.92 g (typ.)
 HSOP16-P-300-1.00: 0.50 g (typ.)

The following conditions apply to solderability:

***Solderability**

1. Use of Sn-37Pb solder bath
 *solder bath temperature = 230°C
 *dipping time = 5 seconds
 *number of times = once
 *use of R-type flux
2. Use of Sn-3.0Ag-0.5Cu solder bath
 *solder bath temperature = 245°C
 *dipping time = 5 seconds
 *number of times = once
 *use of R-type flux

Block Diagram

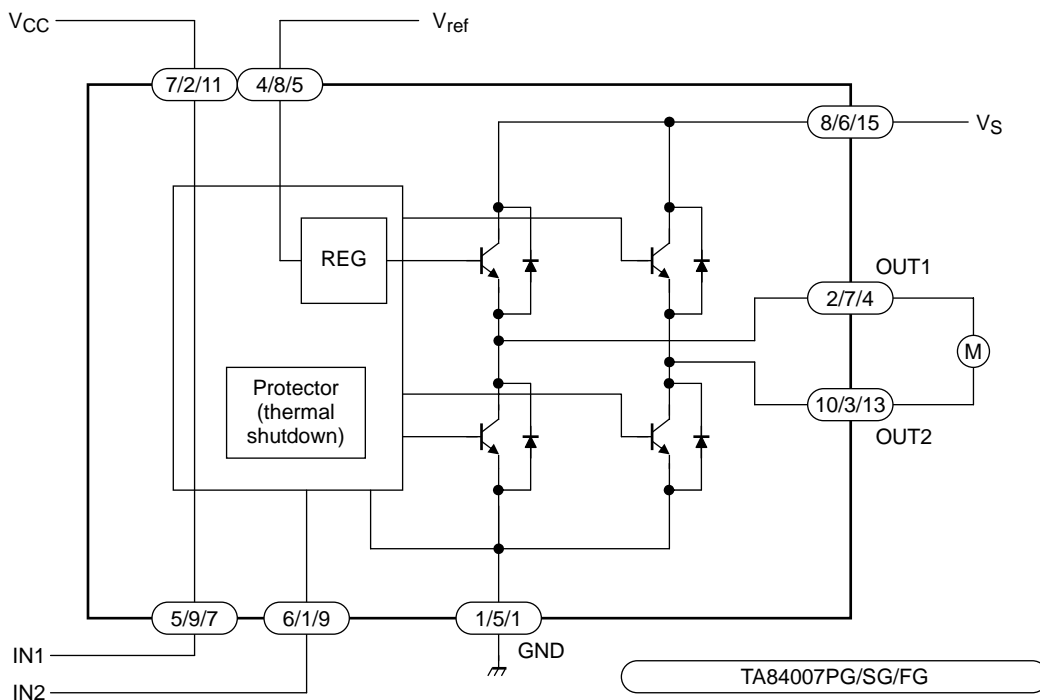

Pin Functions

Symbol	Pin No.			Description
	PQ	SG	FG	
V _{CC}	7	2	11	Logic side power supply pin
V _S	8	6	15	Output side power supply pin
V _{ref}	4	8	5	Control power supply pin
GND	1	5	1	Ground
IN1	5	9	7	Input pin
IN2	6	1	9	Input pin
OUT1	2	7	4	Output pin
OUT2	10	3	13	Output pin

PQ: No. 3 and 9 pins are NC (no connection)

SG: No. 4 pin is NC

FG: No. 2, 3, 6, 8, 10, 12, 14 and 16 pins are NC

Toshiba recommends shorting the TA84007FG's fin to GND.
(The fin is shorted on the rear side of the IC chip and has a grounding electrical potential.)

Function

Input		Output		Mode
IN1	IN2	OUT1	OUT2	
0	0	∞	∞	Stop
1	0	H	L	CW/CCW
0	1	L	H	CCW/CW
1	1	L	L	Brake

∞: High impedance

Note: Input is high-active

Absolute Maximum Ratings (Ta = 25°C)

Characteristics		Symbol	Rating	Unit	
Logic side power supply voltage		V _{CC}	30	V	
		V _{CC (opr.)}	27		
Output side power supply voltage		V _S	30	V	
		V _{S (opr.)}	27		
Control power supply voltage		V _{ref}	30	V	
		V _{ref (opr.)}	27		
Power current	PEAK	PQ	I _{O (PEAK)}	2.0	A
		SG and FG	I _{O (PEAK)}	1.2	
	AVE.	PQ	I _{O (AVE.)}	1.0	
		SG and FG	I _{O (AVE.)}	0.4	
Power dissipation		PQ	P _D	12.5 (Note 1)	W
		SG		0.95 (Note 2)	
		FG		1.4 (Note 3)	
Operating temperature		T _{opr}	-30 to 75	°C	
Storage temperature		T _{stg}	-55 to 150	°C	

Note 1: T_c = 25°C

Note 2: Standalone IC

Note 3: PCB mounting condition (PCB area 60 × 30 × 1.6 mm, occupies copper area of 50% or greater)

Operation power supply voltage range: V_{CC (opr.)} = 4.5 to 27 V

V_{S (opr.)} = 4.5 to 27 V

V_{ref (opr.)} = 4.5 to 27 V

V_{ref} ≤ V_S

Electrical Characteristics (Ta = 25°C, VCC = 5 V, VS = 24 V)

Characteristics		Symbol	Test Circuit	Test Condition	Min.	Typ.	Max.	Unit
Power supply current		ICC1	1	Output OFF, CW/CCW mode	—	11.0	16.0	mA
		ICC2		Output OFF, Stop mode	—	0	50	μA
		ICC3		Output OFF, Brake mode	—	9.5	13.0	mA
Input voltage	1 (high)	VIN1	2	Tj = 25°C	3.5	—	5.5	V
	2 (low)	VIN2			GND	—	0.8	
Input current		IIN		Sink VIN = 3.5 V	—	3	10	μA
Output saturation voltage	SG and FG	Upper	3	Vref = VS output - VS measure IO = 0.2 A, CW/CCW mode	—	0.9	1.2	V
		Lower		Vref = VS output - VS measure IO = 0.2 A, CW/CCW mode	—	0.8	1.2	
	SG and FG	Upper		Vref = VS output - VS measure IO = 0.4 A, CW/CCW mode	—	1.0	1.35	
		Lower		Vref = VS output - VS measure IO = 0.4 A, CW/CCW mode	—	0.9	1.35	
	PQ	Upper		Vref = VS output - VS measure IO = 1.0 A, CW/CCW mode	—	1.3	1.8	
		Lower		Vref = VS output - VS measure IO = 1.0 A, CW/CCW mode	—	1.2	1.85	
Upper side residual voltage	SG and FG	VSAT U-1'	3	Vref = 10 V output - GND measure, IO = 0.2 A, CW/CCW mode	—	11.2	—	V
		VSAT U-2'		Vref = 10 V output - GND measure, IO = 0.4 A, CW/CCW mode	10.4	10.9	12.2	
	PQ	VSAT U-3'		Vref = 10 V output - GND measure, IO = 0.5 A, CW/CCW mode	—	11.0	—	
		VSAT U-4'		Vref = 10 V output - GND measure, IO = 1.0 A, CW/CCW mode	10.2	10.7	12.0	
Output transistor leakage current		Upper	4	VL = 30 V	—	—	10	μA
		Lower		VL = 30 V	—	—	10	
Diode forward voltage	SG and FG	Upper	5	—	—	1.5	—	V
	PQ	Lower		—	—	2.5	—	
	SG and FG	Upper		—	—	0.9	—	
	PQ	Lower		—	—	1.2	—	
Control power supply current		Iref	2	Vref = 10 V, source type	—	—	40	μA

Test Circuit 1.

I_{CC1} , I_{CC2} , I_{CC3}

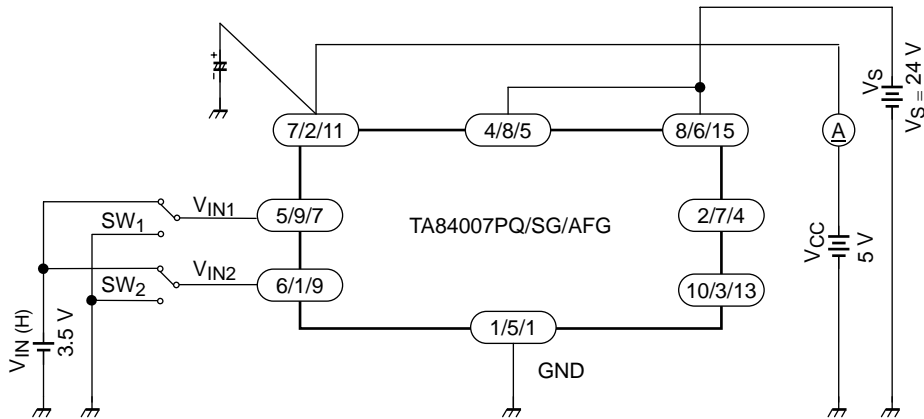

TA84007FG's fin is shorted to GND

Test Circuit 2.

V_{IN1} , V_{IN2} , I_{IN} , I_{ref}

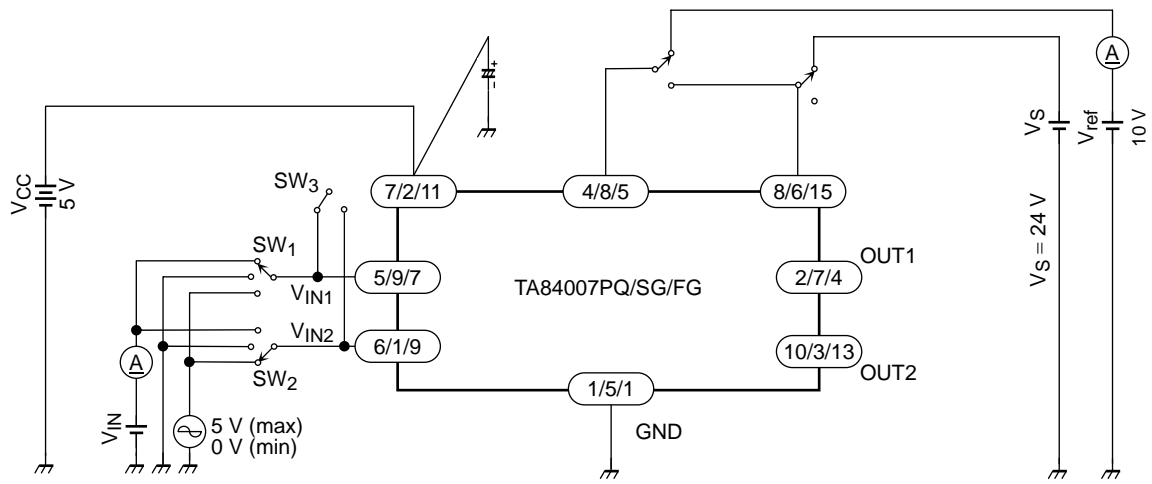

TA84007PQ/SG/FG

TA84007FG's fin is shorted to GND

Test Circuit 3.

$V_{SAT\ U-1, 2, 3}$ $V_{SAT\ L-1, 2, 3}$ $V_{SAT\ U-1', 2', 3', 4'}$

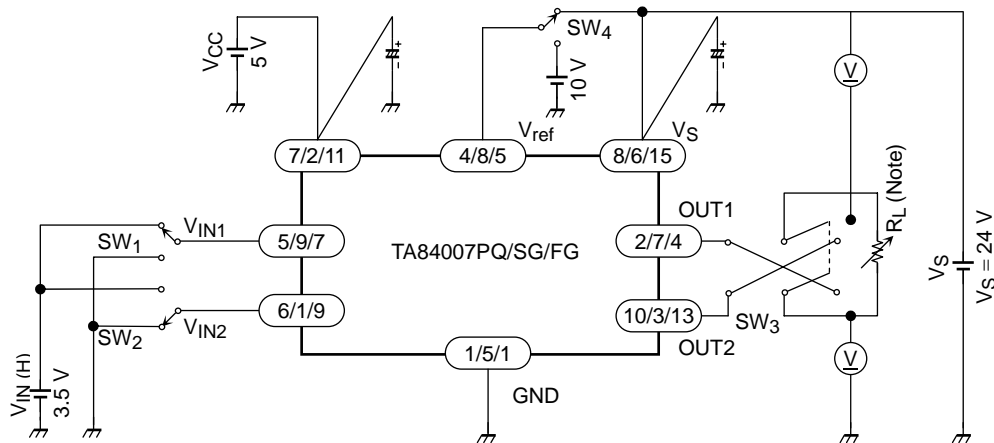

TA84007FG's fin is shorted to GND

Note: Use R_L to calibrate I_{OUT} to 0.2 A, 0.4 A, 0.5 A or 1.0 A.

Test Circuit 4.

$I_{LU, L}$

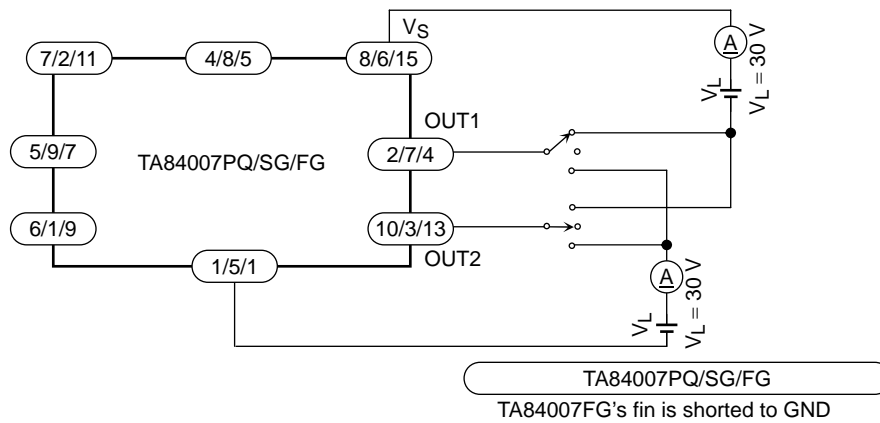

Test Circuit 5.

$V_{FU-1, 2}$ $V_{FL-1, 2}$

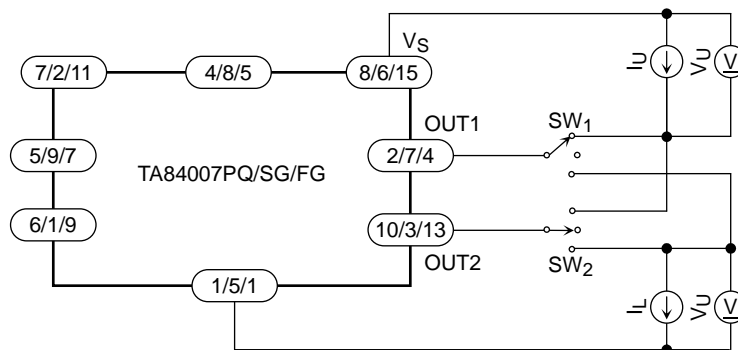

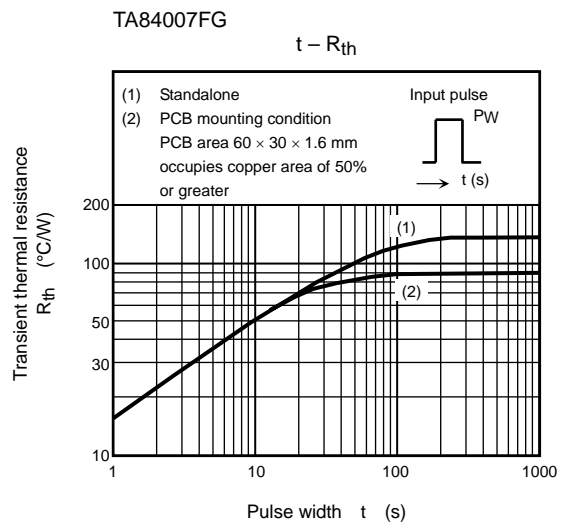
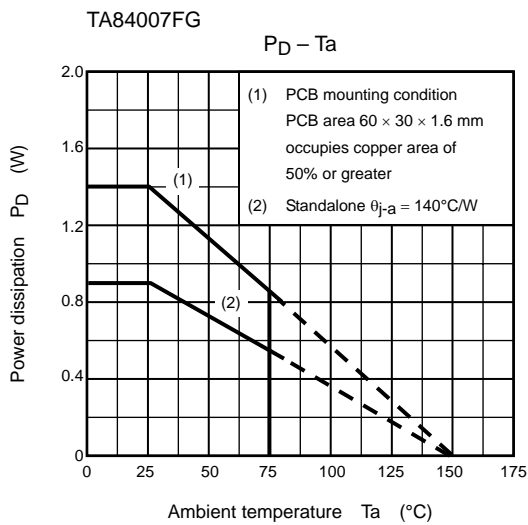
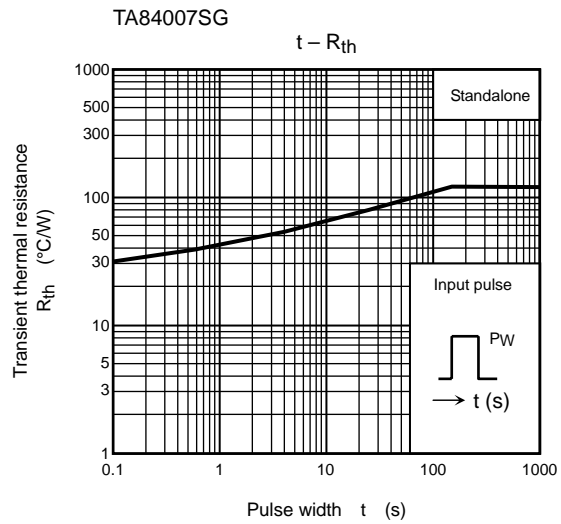
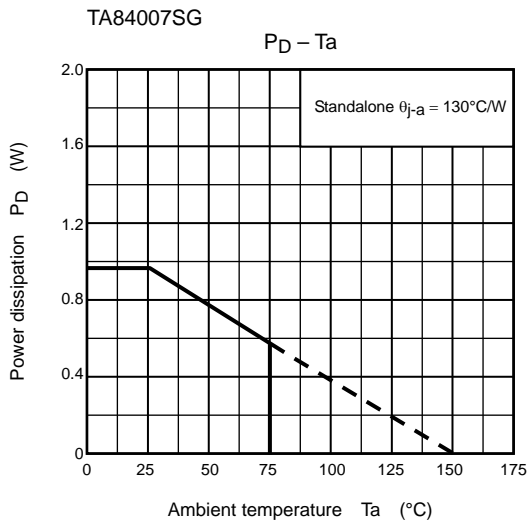
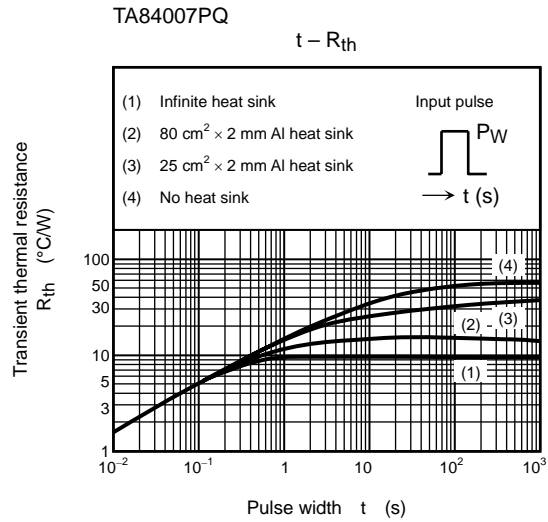
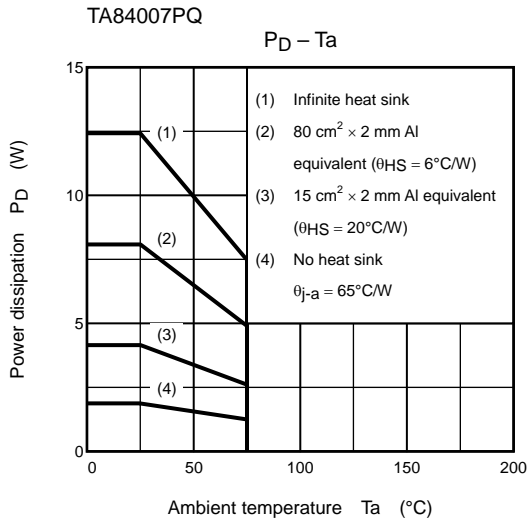

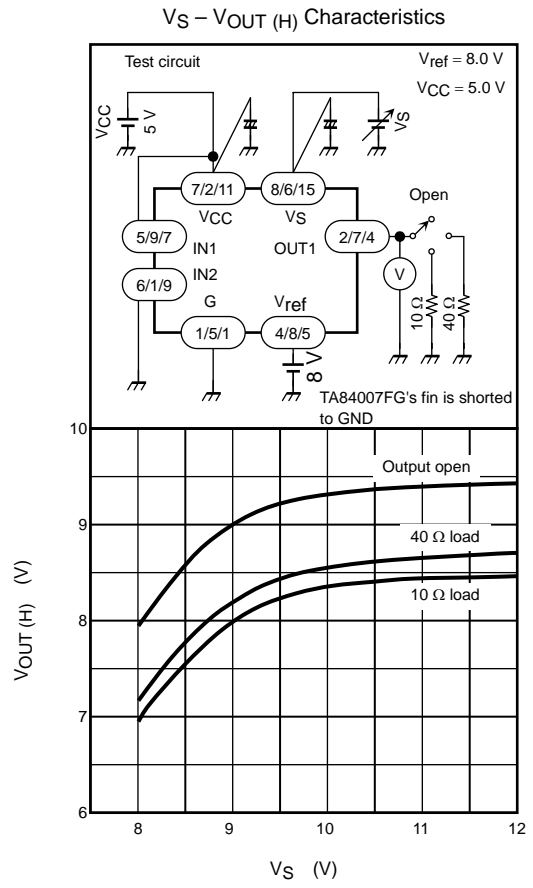
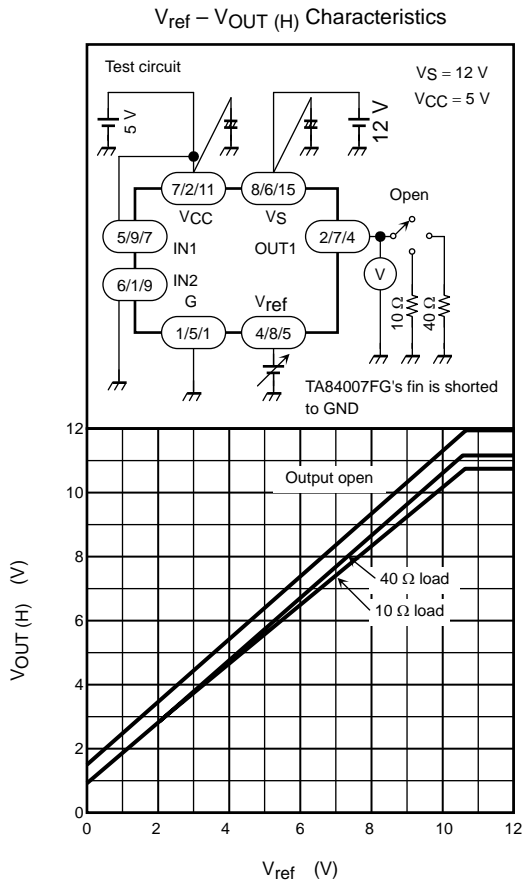
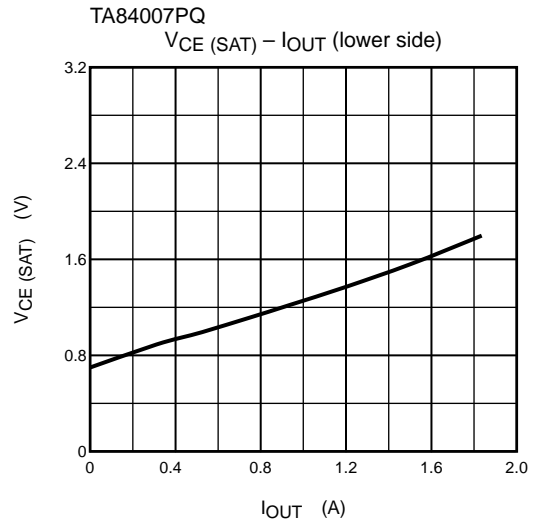
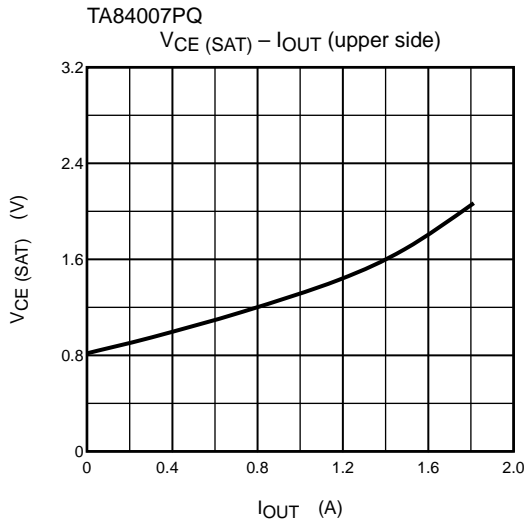

Usage Precautions

Power Input

When turning on the power, first apply power to V_{CC} and then apply power to V_S . (NOTE: It is also okay to apply power to both at the same time.) When turning off the power, first turn off V_S and then turn off V_{CC} . (NOTE: It is also okay to turn off both at the same time.)

Input Circuitry

As shown in the drawing, input is high-active. When you apply the defined V_{IN} (H) amount of voltage (or greater), the logic will go high and if you apply the defined V_{IN} (L) amount of voltage (or lower) the corresponding pin will be grounded and logic will go low.

In addition, when logic is high, input current I_{IN} will be inputted so be careful of the prior stage's output impedance.

Input hysteresis is 0.7 V (typ.)

When turning on the power (V_{CC}), keep input (both IN1 and IN2) low.

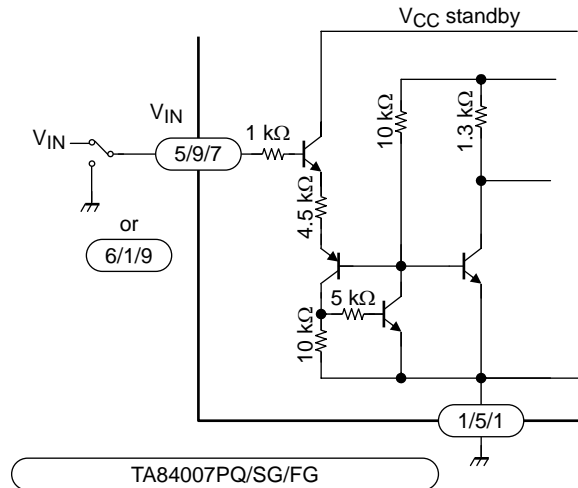

Output Circuitry

Output “H” Voltage

- **V_{ref} Voltage Operation**
The voltage applied to V_{ref} is filtered through the V_{ref} circuit and the resulting $2V_{BE}$ (small signal) high voltage is applied to Q2 ($P_w T_r$)'s base-A. The resulting V_{BE} (Q2) low voltage is output as V_{OUT} (H).
 $V_{OUT} = V_{ref} + 2V_{BE} - V_{BE} (Q2) @ V_{ref} + 0.7 V$
- **About the V_{ref} Pin**
When you aren't using the V_{ref} pin, don't leave it open but rather connect it to the V_S pin using protective resistance (of 3 kΩ or higher). Also, design your application so that $V_{ref} \leq V_S$.

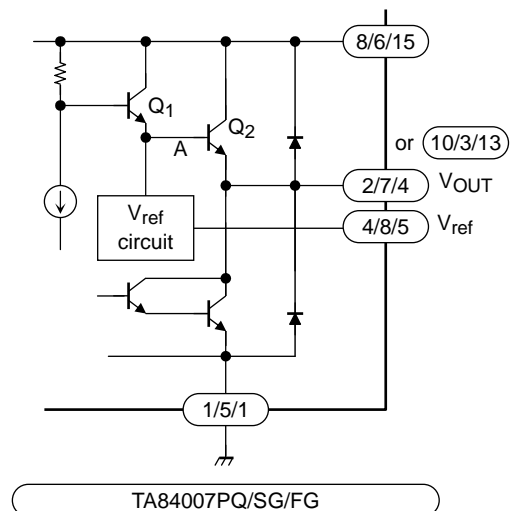

Protector Function

Overcurrent Protection

If the current flowing to the upper power transistor is detected as being over the configured current threshold (about 2.5 A), the overcurrent protector turns off all output. However, this doesn't protect against all potential overcurrent scenarios. For example, it is possible to destroy the IC due to an output short-circuit or grounding fault prior to the overcurrent protector even being activated. Please connect a resistor or fuse to the power (V_S) line as protection against such overcurrent scenarios. (Refer to the application example on the next page.)

Thermal Shutdown

If the chip's temperature is detected as being over the configured temperature threshold (about 170°C), the thermal shutdown circuit turns off all output.

Application Example

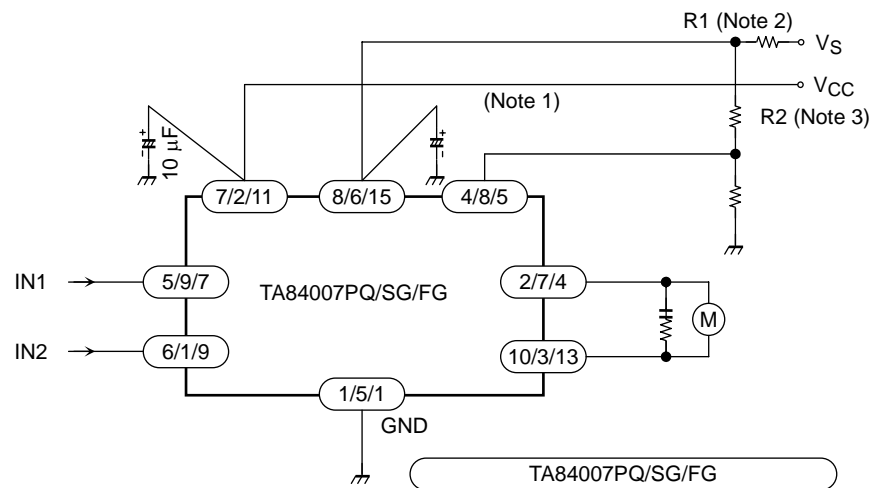

Note 1: Experiment to determine the optimum capacity value (22 µF or greater) for the capacitor. Position the capacitor near the pin (within 20 mm).

Note 2: Use a current limiting resistor (R1) to protect against overcurrent.

Note 3: If you wish to use the IC with $V_S = V_{ref}$, use a resistor to protect against V_{ref} pin surge

Note 4: Utmost care is necessary in the design of the output, V_{CC} , V_M , and GND lines since the IC may be destroyed by short-circuiting between outputs, air contamination faults, or faults due to improper grounding, or by short-circuiting between contiguous pins.

Application Precautions

- Insert a stop (of about 100 µs) during switching (forward U reverse, forward/reverse U brake) to prevent against in-rush current flow.
- IC functionality is not guaranteed when the IC is being powered on and off. Please confirm that there will be no problems in your application in this regard.

Package Dimensions

HSIP10-P-2.54

Unit : mm

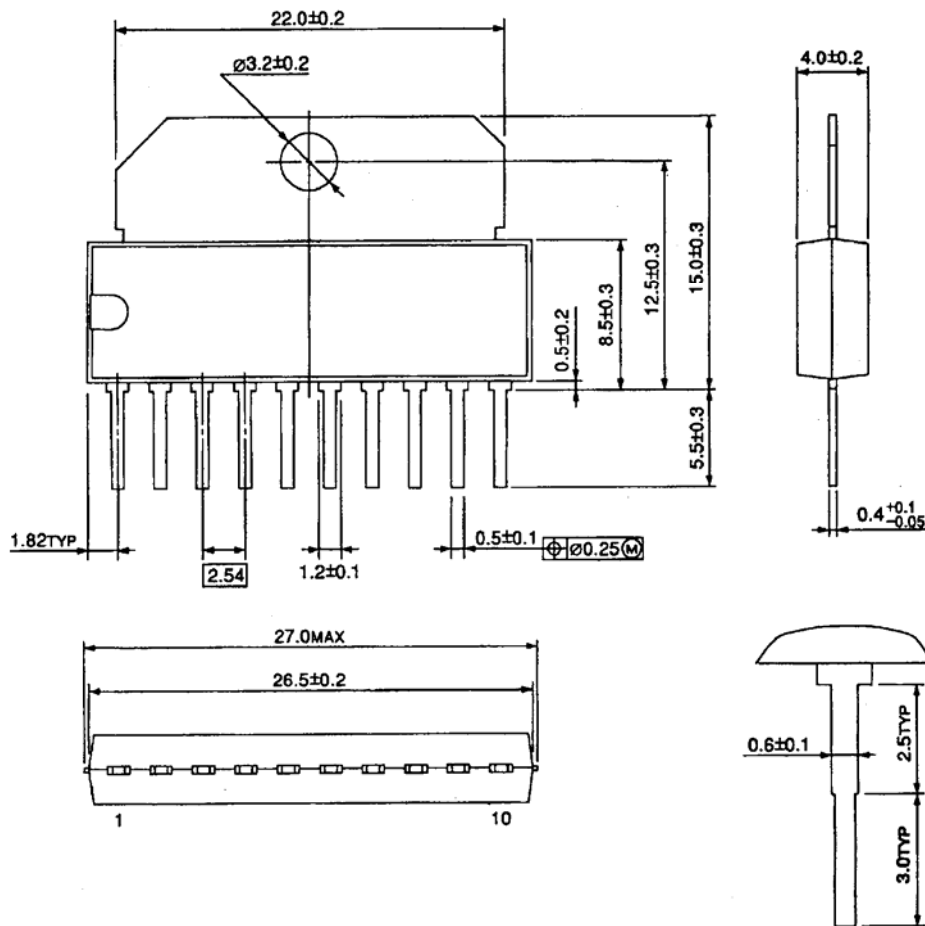

Weight: 2.47 g (typ.)

Package Dimensions

SIP9-P-2.54A

Unit : mm

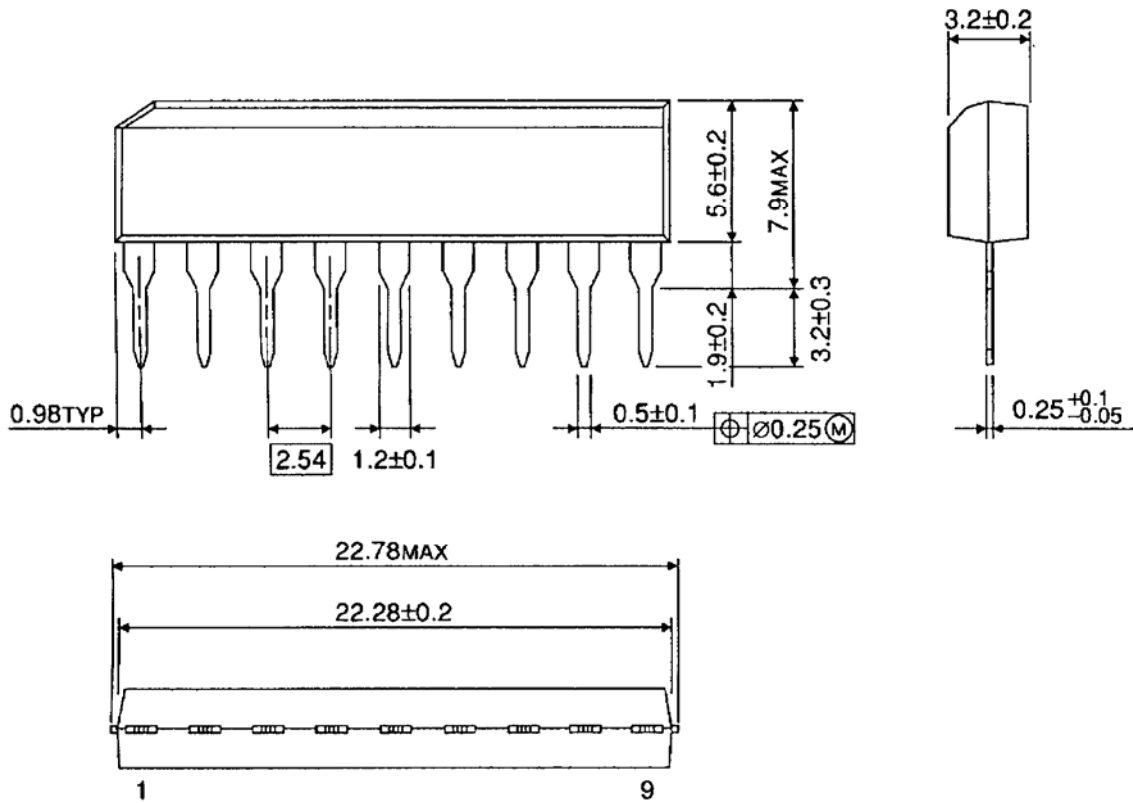

Weight: 0.92 g (typ.)

Package Dimensions

HSOP16-P-300-1.00

Unit : mm

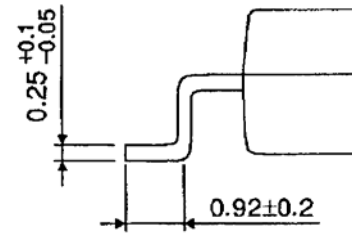
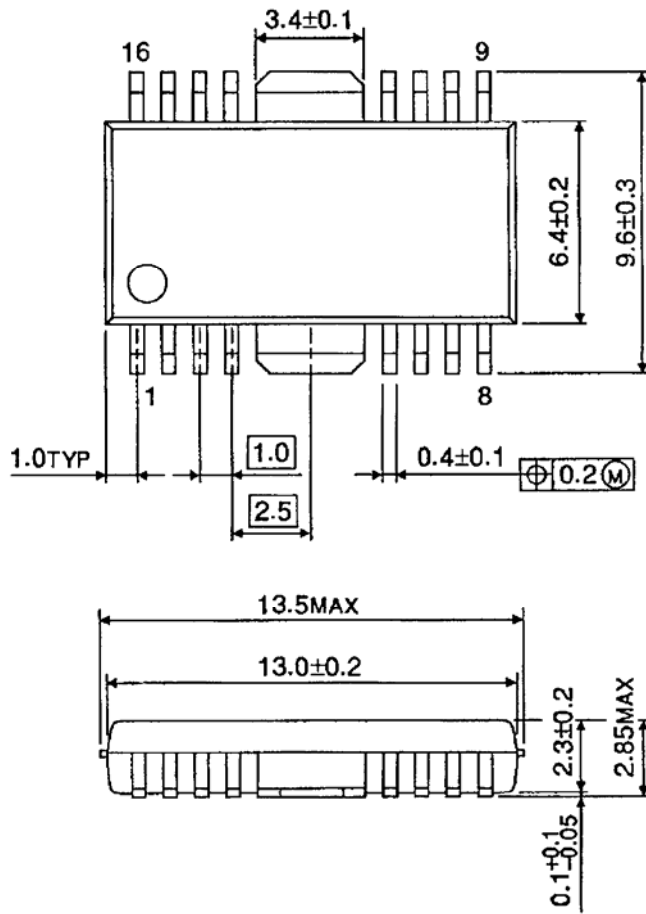

Weight: 0.50 g (typ.)

Notes on Contents

1. Block Diagrams

Some of the functional blocks, circuits, or constants in the block diagram may be omitted or simplified for explanatory purposes.

2. Equivalent Circuits

The equivalent circuit diagrams may be simplified or some parts of them may be omitted for explanatory purposes.

3. Timing Charts

Timing charts may be simplified for explanatory purposes.

4. Application Circuits

The application circuits shown in this document are provided for reference purposes only. Thorough evaluation is required, especially at the mass production design stage.

Toshiba does not grant any license to any industrial property rights by providing these examples of application circuits.

5. Test Circuits

Components in the test circuits are used only to obtain and confirm the device characteristics. These components and circuits are not guaranteed to prevent malfunction or failure from occurring in the application equipment.

IC Usage Considerations

Notes on handling of ICs

- [1] The absolute maximum ratings of a semiconductor device are a set of ratings that must not be exceeded, even for a moment. Do not exceed any of these ratings.
Exceeding the rating(s) may cause the device breakdown, damage or deterioration, and may result injury by explosion or combustion.
- [2] Use an appropriate power supply fuse to ensure that a large current does not continuously flow in case of over current and/or IC failure. The IC will fully break down when used under conditions that exceed its absolute maximum ratings, when the wiring is routed improperly or when an abnormal pulse noise occurs from the wiring or load, causing a large current to continuously flow and the breakdown can lead smoke or ignition. To minimize the effects of the flow of a large current in case of breakdown, appropriate settings, such as fuse capacity, fusing time and insertion circuit location, are required.
- [3] If your design includes an inductive load such as a motor coil, incorporate a protection circuit into the design to prevent device malfunction or breakdown caused by the current resulting from the inrush current at power ON or the negative current resulting from the back electromotive force at power OFF. IC breakdown may cause injury, smoke or ignition.
Use a stable power supply with ICs with built-in protection functions. If the power supply is unstable, the protection function may not operate, causing IC breakdown. IC breakdown may cause injury, smoke or ignition.
- [4] Do not insert devices in the wrong orientation or incorrectly.
Make sure that the positive and negative terminals of power supplies are connected properly. Otherwise, the current or power consumption may exceed the absolute maximum rating, and exceeding the rating(s) may cause the device breakdown, damage or deterioration, and may result injury by explosion or combustion.
In addition, do not use any device that is applied the current with inserting in the wrong orientation or incorrectly even just one time.

Points to remember on handling of ICs**(1) Over current Protection Circuit**

Over current protection circuits (referred to as current limiter circuits) do not necessarily protect ICs under all circumstances. If the Over current protection circuits operate against the over current, clear the over current status immediately.

Depending on the method of use and usage conditions, such as exceeding absolute maximum ratings can cause the over current protection circuit to not operate properly or IC breakdown before operation. In addition, depending on the method of use and usage conditions, if over current continues to flow for a long time after operation, the IC may generate heat resulting in breakdown.

(2) Thermal Shutdown Circuit

Thermal shutdown circuits do not necessarily protect ICs under all circumstances. If the thermal shutdown circuits operate against the over temperature, clear the heat generation status immediately.

Depending on the method of use and usage conditions, such as exceeding absolute maximum ratings can cause the thermal shutdown circuit to not operate properly or IC breakdown before operation.

(3) Heat Radiation Design

In using an IC with large current flow such as power amp, regulator or driver, please design the device so that heat is appropriately radiated, not to exceed the specified junction temperature (T_J) at any time and condition. These ICs generate heat even during normal use. An inadequate IC heat radiation design can lead to decrease in IC life, deterioration of IC characteristics or IC breakdown. In addition, please design the device taking into consideration the effect of IC heat radiation with peripheral components.

(4) Back-EMF

When a motor rotates in the reverse direction, stops or slows down abruptly, a current flow back to the motor's power supply due to the effect of back-EMF. If the current sink capability of the power supply is small, the device's motor power supply and output pins might be exposed to conditions beyond maximum ratings. To avoid this problem, take the effect of back-EMF into consideration in system design.

RESTRICTIONS ON PRODUCT USE

060116EBA

- The information contained herein is subject to change without notice. 021023_D
- TOSHIBA is continually working to improve the quality and reliability of its products. Nevertheless, semiconductor devices in general can malfunction or fail due to their inherent electrical sensitivity and vulnerability to physical stress. It is the responsibility of the buyer, when utilizing TOSHIBA products, to comply with the standards of safety in making a safe design for the entire system, and to avoid situations in which a malfunction or failure of such TOSHIBA products could cause loss of human life, bodily injury or damage to property.
In developing your designs, please ensure that TOSHIBA products are used within specified operating ranges as set forth in the most recent TOSHIBA products specifications. Also, please keep in mind the precautions and conditions set forth in the "Handling Guide for Semiconductor Devices," or "TOSHIBA Semiconductor Reliability Handbook" etc. 021023_A
- The TOSHIBA products listed in this document are intended for usage in general electronics applications (computer, personal equipment, office equipment, measuring equipment, industrial robotics, domestic appliances, etc.). These TOSHIBA products are neither intended nor warranted for usage in equipment that requires extraordinarily high quality and/or reliability or a malfunction or failure of which may cause loss of human life or bodily injury ("Unintended Usage"). Unintended Usage include atomic energy control instruments, airplane or spaceship instruments, transportation instruments, traffic signal instruments, combustion control instruments, medical instruments, all types of safety devices, etc. Unintended Usage of TOSHIBA products listed in this document shall be made at the customer's own risk. 021023_B
- The products described in this document shall not be used or embedded to any downstream products of which manufacture, use and/or sale are prohibited under any applicable laws and regulations. 060106_Q
- The information contained herein is presented only as a guide for the applications of our products. No responsibility is assumed by TOSHIBA for any infringements of patents or other rights of the third parties which may result from its use. No license is granted by implication or otherwise under any patent or patent rights of TOSHIBA or others. 021023_C
- The products described in this document are subject to the foreign exchange and foreign trade laws. 021023_E