

TA8213K

AUDIO POWER AMPLIFIER

The TA8213K is audio power amplifier for consumer applications.

This IC provides an output power of 6W (at $V_{CC} = 20V$, $R_L = 8\Omega$, $f = 1kHz$, $THD = 10\%$), it is suitable for power amplifier of TV.

FEATURES

- High output power : $P_{out} = 6W$ (Typ.)
($V_{CC} = 20V$, $R_L = 8\Omega$, $f = 1kHz$, $THD = 10\%$)
- Low Noise : $V_{no} = 0.14mV_{rms}$ (Typ.)
($V_{CC} = 20V$, $R_L = 8\Omega$, $G_V = 34dB$, $R_g = 10k\Omega$, $BW = 20Hz \sim 20kHz$)
- Very few external parts
- Built in thermal shut down protector circuit
- Operation Supply Voltage Range : $V_{CC(opr)} = 10 \sim 30V$ ($T_a = 25^\circ C$)

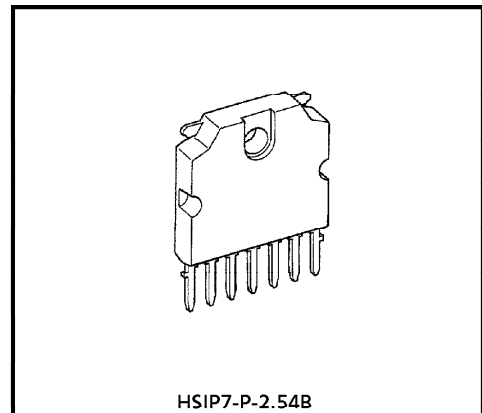

Weight : 2.19g (Typ.)

BLOCK DIAGRAM

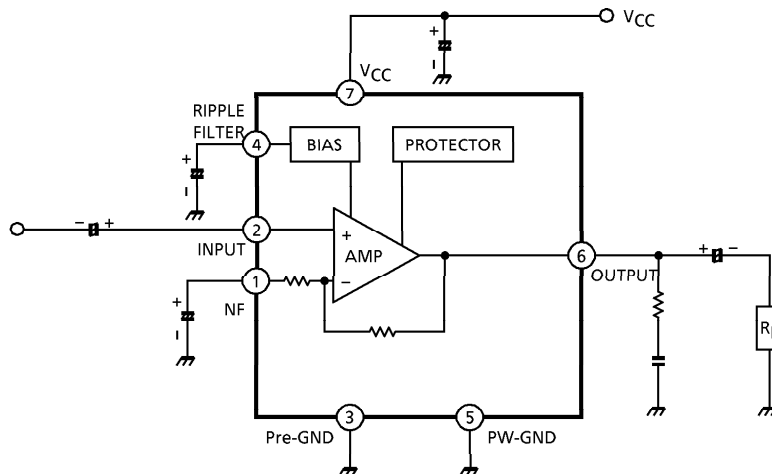

961001EBF2

● TOSHIBA is continually working to improve the quality and the reliability of its products. Nevertheless, semiconductor devices in general can malfunction or fail due to their inherent electrical sensitivity and vulnerability to physical stress. It is the responsibility of the buyer, when utilizing TOSHIBA products, to observe standards of safety, and to avoid situations in which a malfunction or failure of a TOSHIBA product could cause loss of human life, bodily injury or damage to property. In developing your designs, please ensure that TOSHIBA products are used within specified operating ranges as set forth in the most recent products specifications. Also, please keep in mind the precautions and conditions set forth in the TOSHIBA Semiconductor Reliability Handbook.

● This product generates heat during normal operation. However, substandard performance or malfunction may cause the product and its peripherals to reach abnormally high temperatures.
The product is often the final stage (the external output stage) of a circuit. Substandard performance or malfunction of the destination device to which the circuit supplies output may cause damage to the circuit or to the product.

● The products described in this document are subject to foreign exchange and foreign trade control laws.

● The information contained herein is presented only as a guide for the applications of our products. No responsibility is assumed by TOSHIBA CORPORATION for any infringements of intellectual property or other rights of the third parties which may result from its use. No license is granted by implication or otherwise under any intellectual property or other rights of TOSHIBA CORPORATION or others.

● The information contained herein is subject to change without notice.

MAXIMUM RATINGS (Ta = 25°C)

CHARACTERISTIC	SYMBOL	RATING	UNIT
Supply Voltage	V _{CC}	30	V
Output Current	I _O (peak)	2	A
Power Dissipation	P _D (Note)	15	W
Operating Temperature	T _{opr}	- 20~75	°C
Storage Temperature	T _{stg}	- 55~150	°C

(Note) Derated above Ta = 25°C in the proportion of 120mW/°C.

ELECTRICAL CHARACTERISTICS

(Unless otherwise specified, V_{CC} = 20V, R_L = 8Ω, R_G = 600Ω, f = 1kHz, Ta = 25°C)

CHARACTERISTIC	SYMBOL	TEST CIRCUIT	TEST CONDITION	MIN.	TYP.	MAX.	UNIT
Quiescent Current	I _{CCQ}	—	V _{in} = 0	—	45	65	mA
Output Power	P _{out} (1)	—	THD = 10%	5.0	6.0	—	W
	P _{out} (2)	—	THD = 1%	—	4.5	—	
Total Harmonic Distortion	THD	—	P _{OUT} = 2W	—	0.1	0.7	%
Voltage Gain	G _V	—	V _{OUT} = 0.775V _{rms} (0dBm)	32.5	34.0	35.5	dB
Input Resistance	R _{IN}	—		—	30	—	kΩ
Ripple Rejection Ratio	R.R.	—	R _g = 0, f _{ripple} = 100Hz V _{ripple} = 0.775V _{rms} (0dBm)	- 45	- 57	—	dB
Output Noise Voltage	V _{no}	—	R _g = 10kΩ BW = 20Hz~20kHz	—	0.14	0.3	mV _{rms}

TEST CIRCUIT

