

TOSHIBA Bipolar Linear Integrated Circuit Silicon Monolithic

TA8210AHQ, TA8210ALQ

20W BTL × 2ch Audio Power Amplifier

The thermal resistance θ_{j-T} of TA8210AHQ, TA8210ALQ package designed for low thermal resistance, has a high efficiency of heat radiation.

The temperature rise of chip can be reduced, and the influence from the degradation of the features due to the temperature rise at the high output can also be reduced.

This stereo audio power IC, designed for car audio use, has two built-in channels to reduce the characteristic difference between L and R channels.

In addition, the functions of stand-by and muting, and a variety of protection circuits are involved.

Features

- Low thermal resistance
: $\theta_{j-T} = 1.5^{\circ}\text{C} / \text{W}$ (infinite heat sink)
- High power
: $P_{\text{OUT}}(1) = 22\text{W (typ.)} / \text{channel}$
($V_{\text{CC}} = 14.4\text{V}$, $f = 1\text{kHz}$, $\text{THD} = 10\%$, $R_{\text{L}} = 4\Omega$)
 $P_{\text{OUT}}(2) = 19\text{W (typ.)} / \text{channel}$
($V_{\text{CC}} = 13.2\text{V}$, $f = 1\text{kHz}$, $\text{THD} = 10\%$, $R_{\text{L}} = 4\Omega$)
- Low distortion ratio: $\text{THD} = 0.04\% \text{ (typ.)}$ ($V_{\text{CC}} = 13.2\text{V}$, $f = 1\text{kHz}$, $P_{\text{OUT}} = 1\text{W}$, $R_{\text{L}} = 4\Omega$, $G_{\text{V}} = 50\text{dB}$)
- Low noise: $V_{\text{NO}} = 0.30\text{mV}_{\text{RMS}} \text{ (typ.)}$ ($V_{\text{CC}} = 13.2\text{V}$, $R_{\text{L}} = 4\Omega$, $G_{\text{V}} = 50\text{dB}$, $R_{\text{g}} = 0\Omega$, $\text{BW} = 20\text{Hz} \sim 20\text{kHz}$)
- Built-in stand-by function (with pin(4) set at low, power is turned off.): $I_{\text{SB}} = 1\mu\text{A (typ.)}$
- Built-in muting function (with pin(1) set at low, power is turned off.): $V_{\text{(mute)}} = 1\text{V (typ.)}$
- Built-in various protection circuits
Protection circuits: Thermal shut down, Over voltage, Out→ V_{CC} short, Out→GND short and Out-Out short.
- Operating supply voltage: $V_{\text{CC}} = 9 \sim 18\text{V}$

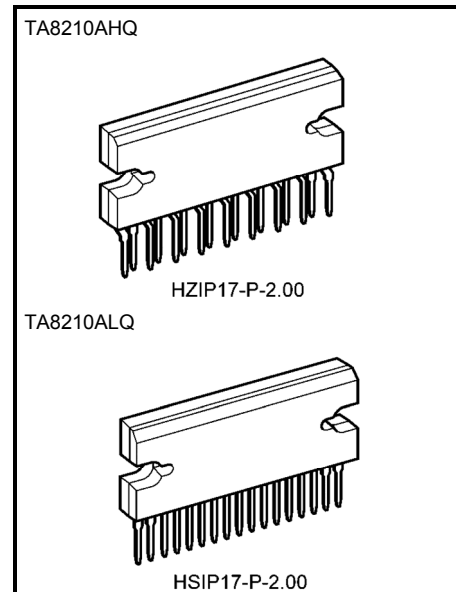

Weight
 HZIP17-P-2.00: 9.8g (typ.)
 HSIP17-P-2.00: 9.8g (typ.)

Block Diagram

TA8210AHQ, TA8210ALQ ($G_V = 50\text{dB}$)

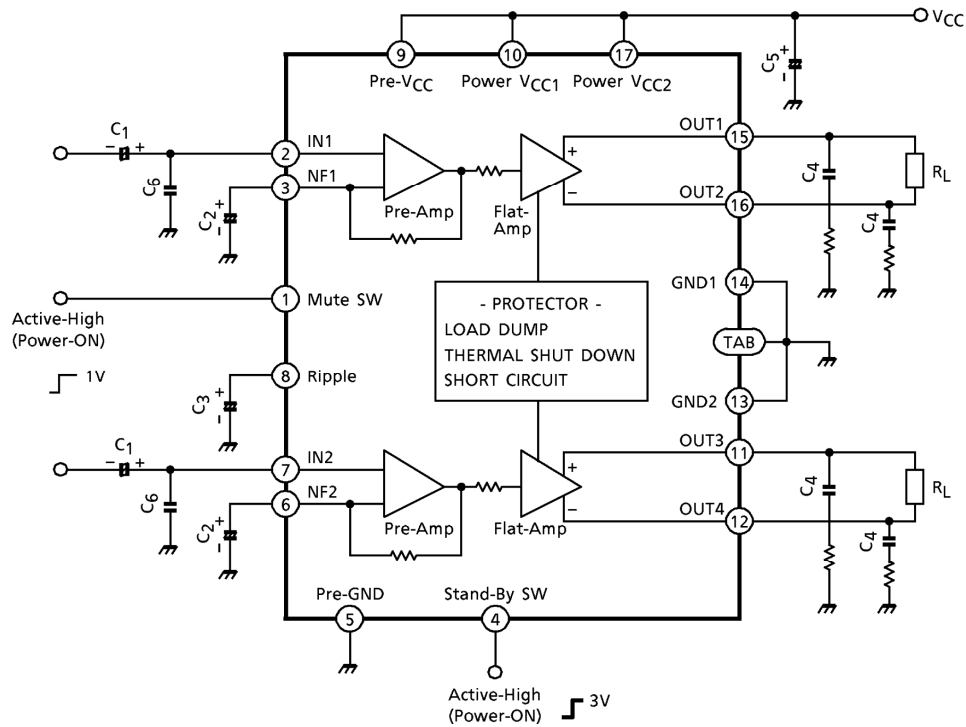

Cautions And Application Method (description is made only on the single channel.)

1. Voltage gain adjustment

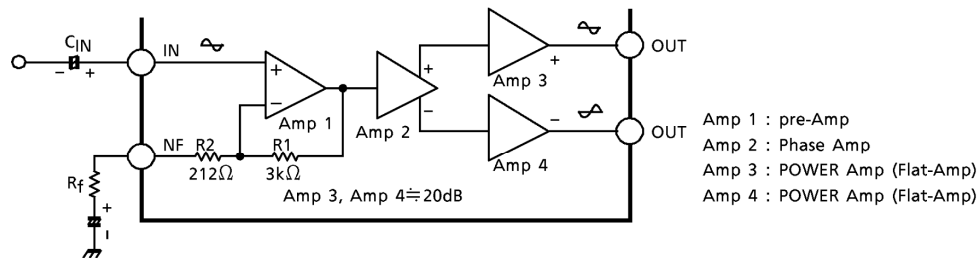

Fig.1

This IC has the amplifier construction as shown in Fig.1. The pre-amp (amp 1) is provided to the primary stage, and the input voltage is amplified by the flat amps, amp 3 and amp 4 of each channel through the phase amp. (Amp 2).

Since the input offset is prevented by pre-amp when VCC is set to on, this circuit can remarkably reduce the pop noise.

The total closed loop gain G_V of this IC can be obtained by expression below when the closed loop voltage gain of amp 1 is G_{V1} .

$$G_{V1} = 20 \log \frac{R1 + (R_f + R2)}{R_f + R2} \text{ (dB)} \quad \dots (1)$$

The closed loop voltage gain of power amp, amp 3 and amp 4 is fixed at $G_{V3} \approx G_{V4} = 20\text{dB}$. Therefore, the total closed circuit voltage gain G_V is obtained through BTL connection by the expression below.

$$G_V = G_{V1} + G_{V3} + 6 \text{ (dB)} \quad \dots (2)$$

For example, when $R_f = 0\Omega$, G_V is obtained by the expressions (1) and (2) as shown below.

$$G_V \approx 24 + 20 + 6 = 50\text{dB}$$

The voltage gain is reduced when R_f is increased. (Fig.2) With the voltage gain reduced, since (1) the oscillation stability is reduced, and (2) the pop noise changes when V_{CC} is set to on, refer to the items 3 and 4.

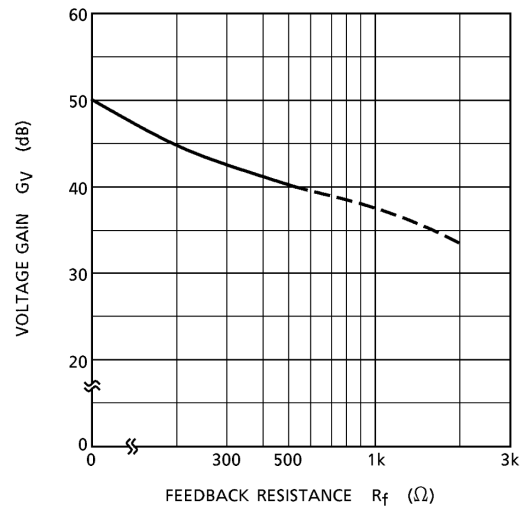

Fig.2

2. Stand-by SW function

By means of controlling pin(4) (stand-by terminal) to high and low, the power supply can be set to on and off. The threshold voltage of pin(4) is set at 2.1V ($3V_{BE}$), and the power supply current is about 1 μ A (typ.) at the stand-by state.

Pin(4) control voltage : $V_{(SB)}$

Stand-by	Power	$V_{(SB)}$ (V)
On	Off	0~2
Off	On	3~ V_{CC}

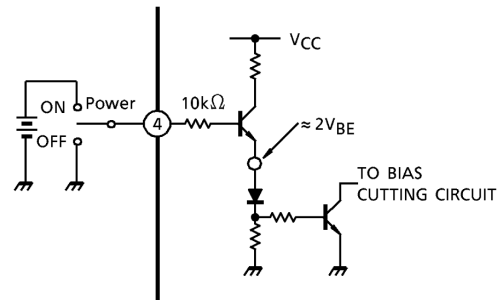
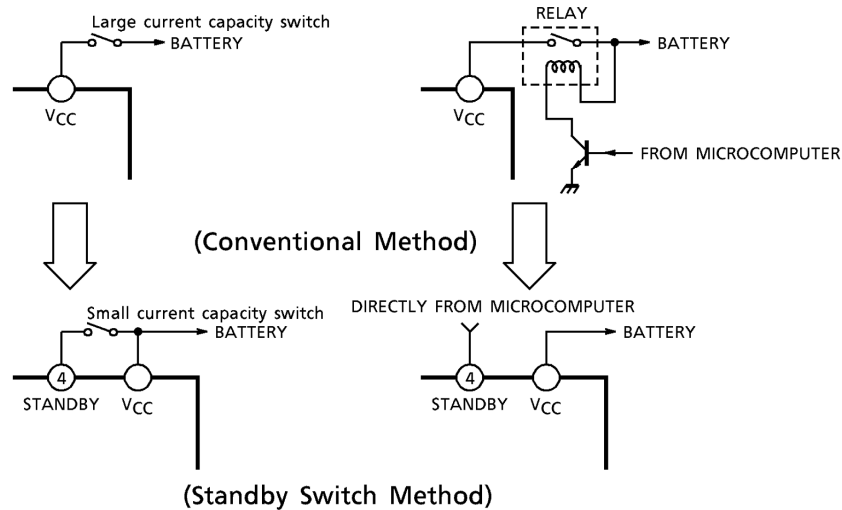

Fig.3 With pin(4) set to high, power is on.

Advantage of stand-by SW

- (1) Since V_{CC} can directly be controlled to on / off by the microcomputer, the switching relay can be omitted.
- (2) Since the control current is microscopic, the switching relay of small current capacity is satisfactory for switching.



3. Preventive measure against oscillation

For preventing the oscillation, it is advisable to use C₄, the condenser of polyester film having small characteristic fluctuation of the temperature and the frequency.

The resistance R to be series applied to C₄ is effective for phase correction of high frequency, and improves the oscillation allowance.

Since the oscillation allowance is varied according to the causes described below, perform the temperature test to check the oscillation allowance.

- (1) Voltage gain to be used (GV setting)
- (2) Capacity value of condenser
- (3) Kind of condenser
- (4) Layout of printed board

In case of its use with the voltage gain GV reduced or with the feedback amount increased, care must be taken because the phase-inversion is caused by the high frequency resulting in making the oscillation viably generated.

4. Input offset prevention circuit at VCC→on

Having Pre-Amp (Amp 1) mounted on the primary stage, this IC contains the circuit for making the Amp 1 input voltage and the NF terminal voltage equipotential.

Therefore, the offset voltage produced at the input stage is suppressed to prevent the pop noise at VCC→on. The capacity values of the input and NF condenser (C₁ and C₂) shall be set according to the gain to be used.

(Reference) (A) At GV = 50dB (R_f = 0Ω)

$$C_1 = 4.7\mu\text{F}, C_2 = 47\mu\text{F}$$

(B) At GV = 40dB (R_f = 470Ω)

$$C_1 = 3.3\mu\text{F}, C_2 = 33\mu\text{F}$$

5. Muting function

Through setting pin(1) (mute terminal) at about 1V or less, muting becomes possible.

The interval circuit of IC is shown in Fig.4.

When pin(1) is set to low, Q1 and Q2 are turned on, the charge of the ripple condenser is discharged and the bias is cut. The mute amount of 60dB or over can be obtained.

Since this muting function rapidly discharge the charge of the ripple filter capacitor of pin(8), the pop noise is generated by the DC fluctuation of the bias section.

Therefore, this muting function is not appropriate to the audio muting but it is effective in muting at V_{CC}→on.

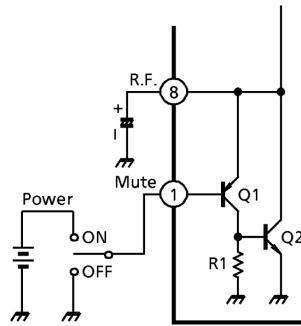

Fig.4 Mute circuit

6. External part list and description

Sym- bol	Recom- mended Value	Feature	Influence		Remarks
			Smaller Than Recommended Value	Larger Than Recommended Value	
C ₁	4.7μF	DC blocking	Related to pop noise at V _{CC} →on.		Related to gain. Refer to item 4.
C ₂	47μF	Feedback condenser	Related to pop noise at V _{CC} →on.		
			Determination of low cut-off frequency. $C_2 = \frac{1}{2\pi \cdot f_L \cdot R_f}$		
C ₃	220μF	Ripple reduction	Time constant is small at V _{CC} →on or off.	Time constant is large at V _{CC} →on or off.	
C ₄	0.12μF	Oscillation prevention	Made liable to oscillate.	Oscillation allowance.	Refer to item 3.
C ₅	1000μF	Ripple filter	For filtering power supply hum and ripple. Large at using AC rectified power supply. Small at using DC power supply.		
C ₆	1000pF	Oscillation prevention	Oscillation allowance improved. Noise reduction		Refer to item 3.

Absolute Maximum Ratings (Ta = 25°C)

Characteristic	Symbol	Rating	Unit
Peak supply voltage (0.2s)	V _{CC} (surge)	50	V
DC supply voltage	V _{CC} (DC)	25	V
Operating supply voltage	V _{CC} (opr)	18	V
Output current (peak)	I _O (peak)	9	A
Power dissipation	P _D	50	W
Operating temperature	T _{opr}	-30~85	°C
Storage temperature	T _{stg}	-55~150	°C

Electrical Characteristics

(unless otherwise specified, V_{CC} = 13.2V, R_L = 4Ω, f = 1kHz, Ta = 25°C)

Characteristic	Symbol	Test Circuit	Test Condition	Min.	Typ.	Max.	Unit
Quiescent supply current	I _{CCQ}	—	V _{IN} = 0	—	120	250	mA
Output power	P _{OUT} (1)	—	V _{CC} = 14.4V, THD = 10%	—	22	—	W
	P _{OUT} (2)	—	THD = 10%	16	19	—	
Total harmonic distortion	THD	—	P _{OUT} = 1W	—	0.04	0.4	%
Voltage gain	G _V	—	—	48	50	52	dB
Output noise voltage	V _{NO}	—	R _g = 0Ω, BW = 20Hz~20kHz	—	0.30	0.70	mV _{rms}
Ripple rejection ratio	R.R.	—	fripple = 100Hz, R _g = 600Ω	40	54	—	dB
Input resistance	R _{IN}	—	—	—	30	—	kΩ
Output offset voltage	V _{offset}	—	V _{IN} = 0	-0.3	0	0.3	V
Current at stand-by state	I _{SB}	—	—	—	1	10	μA
Cross talk	C.T.	—	R _g = 600Ω, V _{OUT} = 0.775V _{rms} (0dBm)	—	60	—	dB
Pni(4) control voltage	V _{SB}	—	Stand-by→off (power→on)	2.5	—	V _{CC}	V
Pin(1) control voltage	V _(mute)	—	Mute→on (power→off)	—	1.0	2.0	V

Test Circuit

TA8210AHQ, TA8210ALQ ($G_V = 50\text{dB}$)

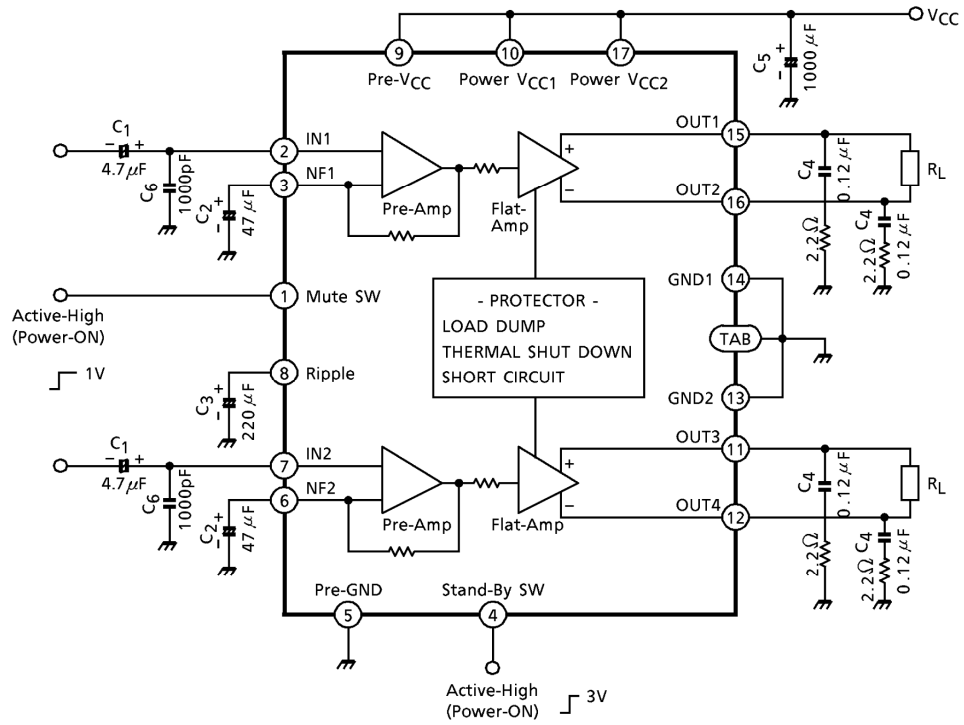

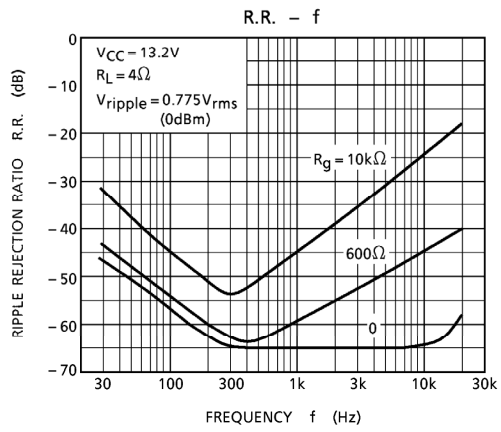
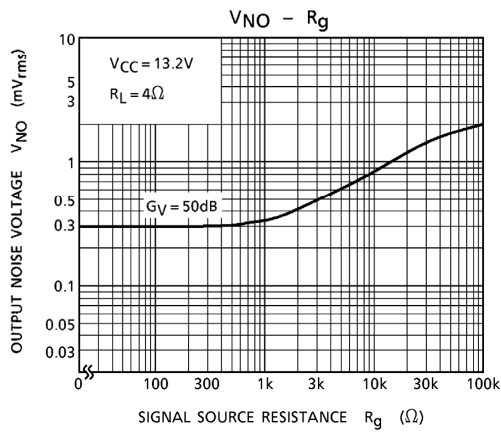
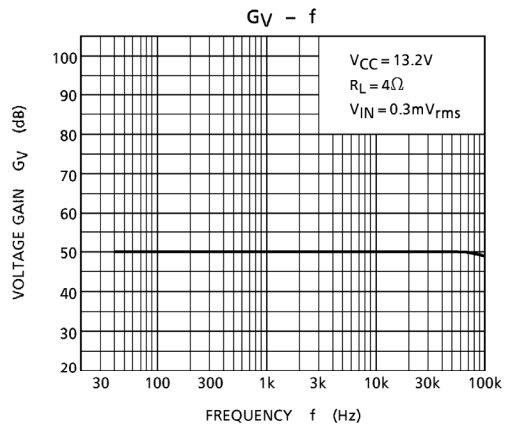
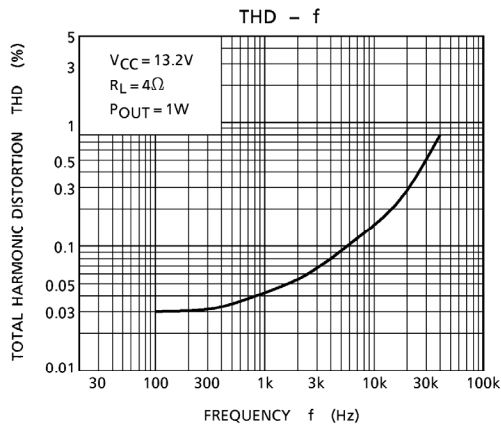
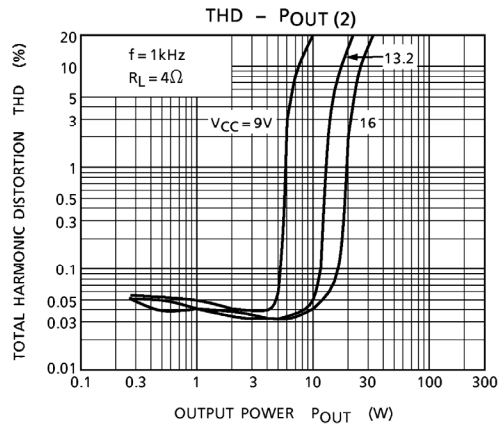
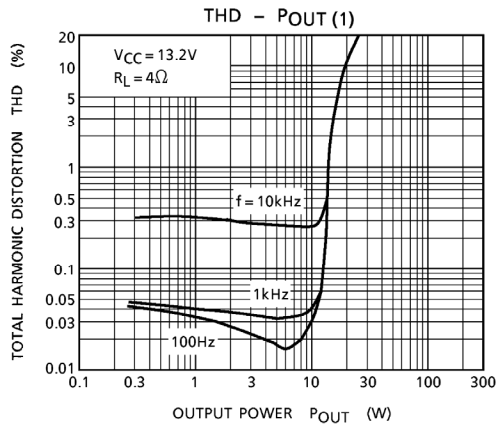

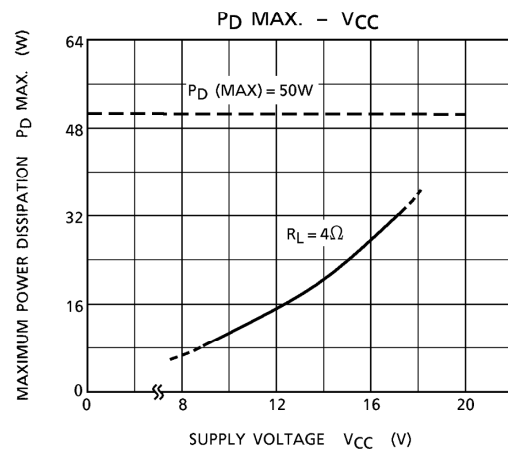
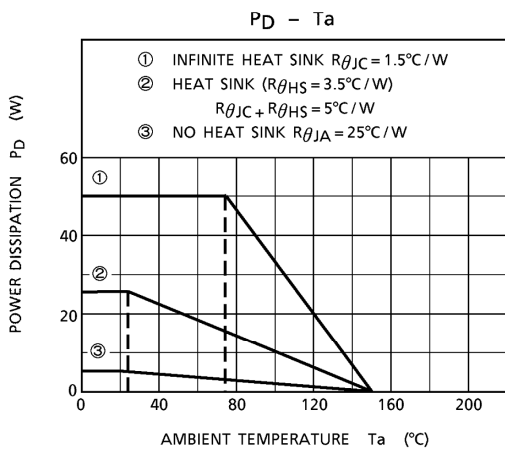
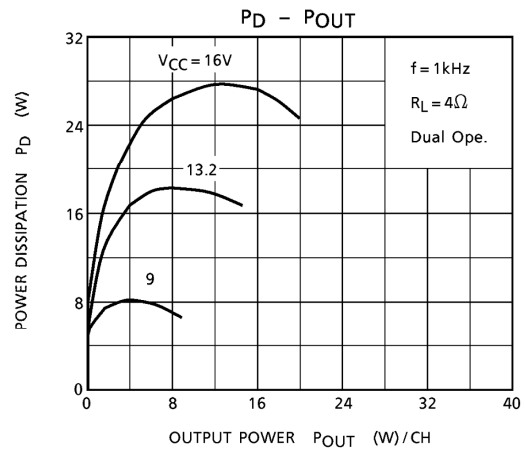
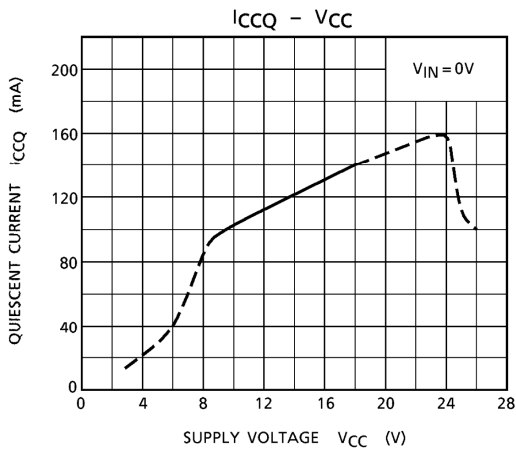
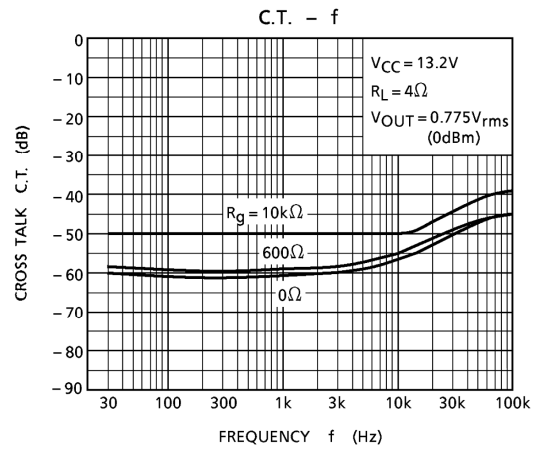
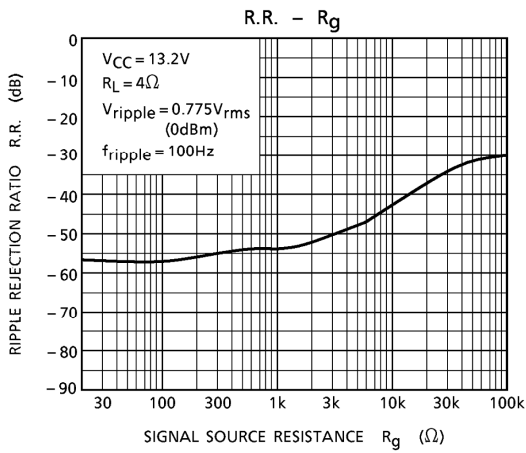

Package Dimensions

HZIP17-P-2.00

Unit : mm

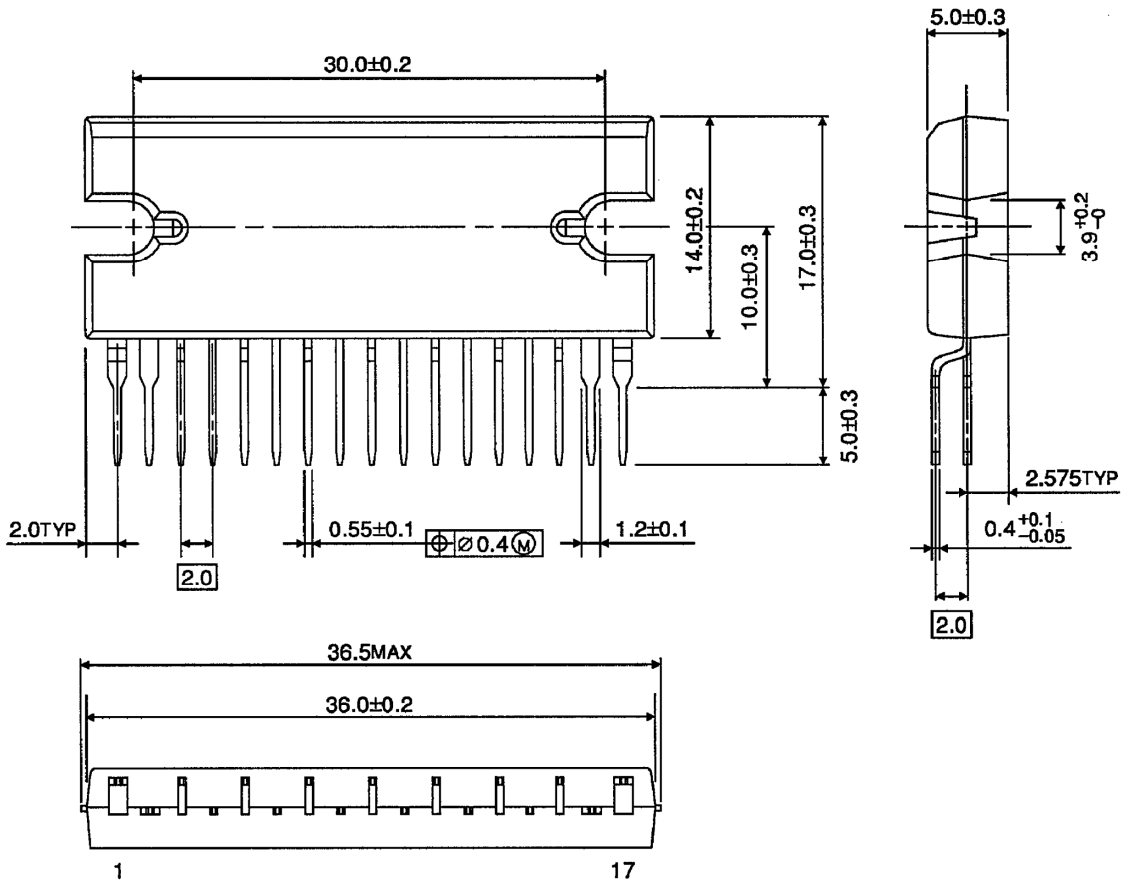

Weight: 9.8g (typ.)

Package Dimensions

HSIP17-P-2.00

Unit : mm

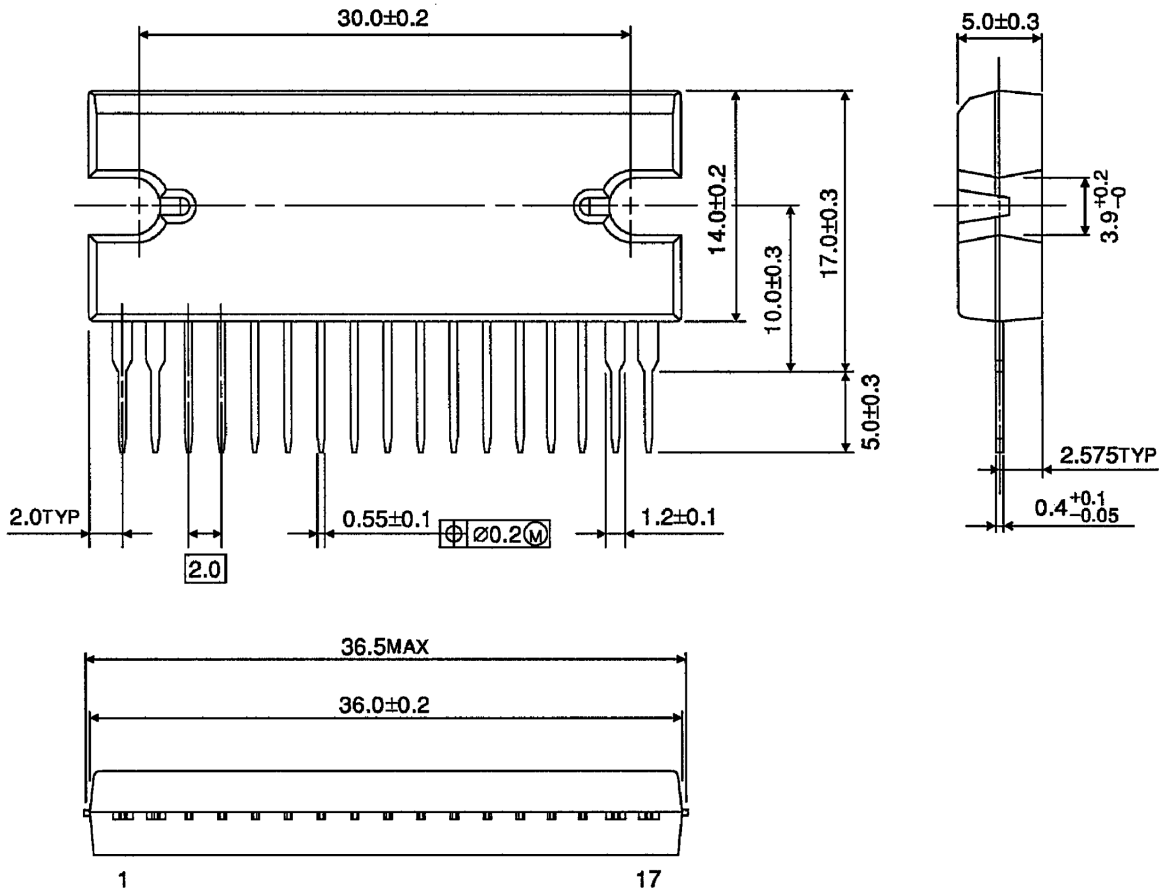

Weight: 9.8g (typ.)

- Use an appropriate power supply fuse to ensure that a large current does not continuously flow in case of over current and/or IC failure. The IC will fully break down when used under conditions that exceed its absolute maximum ratings, when the wiring is routed improperly or when an abnormal pulse noise occurs from the wiring or load, causing a large current to continuously flow and the breakdown can lead smoke or ignition. To minimize the effects of the flow of a large current in case of breakdown, appropriate settings, such as fuse capacity, fusing time and insertion circuit location, are required.
- If your design includes an inductive load such as a motor coil, incorporate a protection circuit into the design to prevent device malfunction or breakdown caused by the current resulting from the inrush current at power ON or the negative current resulting from the back electromotive force at power OFF. For details on how to connect a protection circuit such as a current limiting resistor or back electromotive force adsorption diode, refer to individual IC datasheets or the IC databook. IC breakdown may cause injury, smoke or ignition.
- Use a stable power supply with ICs with built-in protection functions. If the power supply is unstable, the protection function may not operate, causing IC breakdown. IC breakdown may cause injury, smoke or ignition.
- Carefully select external components (such as inputs and negative feedback capacitors) and load components (such as speakers), for example, power amp and regulator. If there is a large amount of leakage current such as input or negative feedback condenser, the IC output DC voltage will increase. If this output voltage is connected to a speaker with low input withstand voltage, overcurrent or IC failure can cause smoke or ignition. (The over current can cause smoke or ignition from the IC itself.) In particular, please pay attention when using a Bridge Tied Load (BTL) connection type IC that inputs output DC voltage to a speaker directly.
- Over current Protection Circuit
Over current protection circuits (referred to as current limiter circuits) do not necessarily protect ICs under all circumstances. If the Over current protection circuits operate against the over current, clear the over current status immediately. Depending on the method of use and usage conditions, such as exceeding absolute maximum ratings can cause the over current protection circuit to not operate properly or IC breakdown before operation. In addition, depending on the method of use and usage conditions, if over current continues to flow for a long time after operation, the IC may generate heat resulting in breakdown.
- Thermal Shutdown Circuit
Thermal shutdown circuits do not necessarily protect ICs under all circumstances. If the Thermal shutdown circuits operate against the over temperature, clear the heat generation status immediately. Depending on the method of use and usage conditions, such as exceeding absolute maximum ratings can cause the thermal shutdown circuit to not operate properly or IC breakdown before operation.
- Heat Radiation Design
When using an IC with large current flow such as power amp, regulator or driver, please design the device so that heat is appropriately radiated, not to exceed the specified junction temperature (T_j) at any time and condition. These ICs generate heat even during normal use. An inadequate IC heat radiation design can lead to decrease in IC life, deterioration of IC characteristics or IC breakdown. In addition, please design the device taking into considerate the effect of IC heat radiation with peripheral components.
- Installation to Heat Sink
Please install the power IC to the heat sink not to apply excessive mechanical stress to the IC. Excessive mechanical stress can lead to package cracks, resulting in a reduction in reliability or breakdown of internal IC chip. In addition, depending on the IC, the use of silicon rubber may be prohibited. Check whether the use of silicon rubber is prohibited for the IC you intend to use, or not. For details of power IC heat radiation design and heat sink installation, refer to individual technical datasheets or IC databooks.

RESTRICTIONS ON PRODUCT USE

060116EBF

- The information contained herein is subject to change without notice. 021023_D
- TOSHIBA is continually working to improve the quality and reliability of its products. Nevertheless, semiconductor devices in general can malfunction or fail due to their inherent electrical sensitivity and vulnerability to physical stress. It is the responsibility of the buyer, when utilizing TOSHIBA products, to comply with the standards of safety in making a safe design for the entire system, and to avoid situations in which a malfunction or failure of such TOSHIBA products could cause loss of human life, bodily injury or damage to property.
In developing your designs, please ensure that TOSHIBA products are used within specified operating ranges as set forth in the most recent TOSHIBA products specifications. Also, please keep in mind the precautions and conditions set forth in the "Handling Guide for Semiconductor Devices," or "TOSHIBA Semiconductor Reliability Handbook" etc. 021023_A
- The TOSHIBA products listed in this document are intended for usage in general electronics applications (computer, personal equipment, office equipment, measuring equipment, industrial robotics, domestic appliances, etc.). These TOSHIBA products are neither intended nor warranted for usage in equipment that requires extraordinarily high quality and/or reliability or a malfunction or failure of which may cause loss of human life or bodily injury ("Unintended Usage"). Unintended Usage include atomic energy control instruments, airplane or spaceship instruments, transportation instruments, traffic signal instruments, combustion control instruments, medical instruments, all types of safety devices, etc. Unintended Usage of TOSHIBA products listed in this document shall be made at the customer's own risk. 021023_B
- The products described in this document shall not be used or embedded to any downstream products of which manufacture, use and/or sale are prohibited under any applicable laws and regulations. 060106_Q
- The information contained herein is presented only as a guide for the applications of our products. No responsibility is assumed by TOSHIBA for any infringements of patents or other rights of the third parties which may result from its use. No license is granted by implication or otherwise under any patent or patent rights of TOSHIBA or others. 021023_C
- The products described in this document are subject to the foreign exchange and foreign trade laws. 021023_E
- This product generates heat during normal operation. However, substandard performance or malfunction may cause the product and its peripherals to reach abnormally high temperatures.
The product is often the final stage (the external output stage) of a circuit. Substandard performance or malfunction of the destination device to which the circuit supplies output may cause damage to the circuit or to the product. 030619_R

About solderability, following conditions were confirmed

- Solderability
 - (1) Use of Sn-37Pb solder Bath
 - solder bath temperature = 230°C
 - dipping time = 5 seconds
 - the number of times = once
 - use of R-type flux
 - (2) Use of Sn-3.0Ag-0.5Cu solder Bath
 - solder bath temperature = 245°C
 - dipping time = 5 seconds
 - the number of times = once
 - use of R-type flux