

# TOSHIBA INTEGRATED CIRCUIT

## TECHNICAL DATA

# TA8129Z

## TOSHIBA BIPOLAR LINEAR INTEGRATED CIRCUIT

### SILICON MONOLITHIC

### FM IF SYSTEM (DIFFERENTIAL PEAK DETECTION)

TA8129Z, an IC designed for car tuner, has a flexible muting function and a station detection function leading to make it possible to realize the feature appropriate to the specification of the car tuner.

- . Differential 6-stage IF Limiter
  - . Signal Meter Output
  - . Differential Peak Detection
  - . Station Detection
  - . Bandwidth Muting
  - . Signal Strength Muting
- . Application of differential peak detection is useful against multi-path distortion.
  - . With single tuned coil, low distortion ratio can be realized. (0.05%, typical at 75kHz dev.)
  - . Sensitivity of signal strength muting, sensitivity of attenuation and stop signal, and bandwidth can freely be set with external resistance.
  - . Signal meter output proportioned to input signal strength can be obtained.
  - . AMR is excellent. (55dB, typical at  $V_i=80\text{dB}\mu$ )
  - . S/N is excellent. (78dB, typical.)
  - . S curve variation against input voltage is made reduced. ( $\pm 100\text{mV}$ , typical at  $V_i=0\sim 120\text{dB}\mu$ )
  - . Operating Power Supply Voltage :  $V_{opr}=7\sim 16\text{V}$  ( $T_a=25^\circ\text{C}$ )

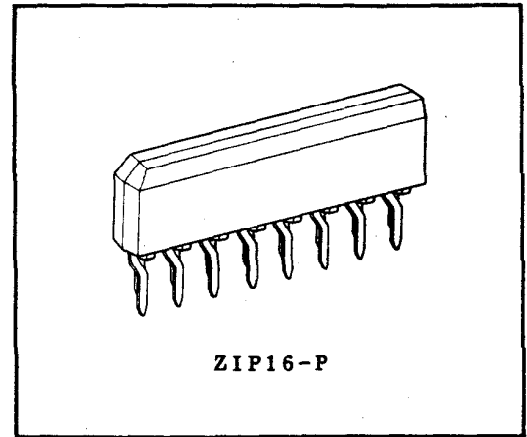

Weight: ZIP16-P: 0.99g (Typ.)

### MAXIMUM RATINGS ( $T_a=25^\circ\text{C}$ )

CHARACTERISTIC	SYMBOL	RATING	UNIT
Power Supply Voltage	$V_{CC}$	16	V
Power Dissipation	$P_D$	750	mW
Operating Temperature	$T_{opr}$	$-30\sim 85$	$^\circ\text{C}$
Storage Temperature	$T_{stg}$	$-55\sim 150$	$^\circ\text{C}$
Tuning Indication Current	I17 MAX.	20	mA
External Leak Current	I13 MAX.	5	mA

Note. Derated above  $25^\circ\text{C}$  in the proportion of  $6\text{mW}/^\circ\text{C}$ .

© The information contained herein is presented only as a guide for the applications of our products. No responsibility is assumed by TOSHIBA CORPORATION for any infringements of intellectual property or other rights of the third parties which may result from its use.  
 No license is granted by implication or otherwise under any intellectual property or other rights of TOSHIBA CORPORATION or others.  
 © These TOSHIBA products are intended for use in general commercial applications (office equipment, communication equipment, measuring equipment, domestic appliance, etc.) please make sure that you consult with us before you use these TOSHIBA products in equipment which requires extraordinarily high quality and/or reliability, and in equipment which may involve life threatening or critical application, including but not limited to such uses as atomic energy control, airplane or spacecraft instrumentation, traffic signals, medical instrumentation, combustion control, all types of safety device, etc. TOSHIBA cannot accept and hereby disclaims liability for any damage which may occur in case the TOSHIBA products are used in such equipment or applications without prior consultation with TOSHIBA.

TA8129Z-1

1993-4-9

TOSHIBA CORPORATION

BLOCK DIAGRAM

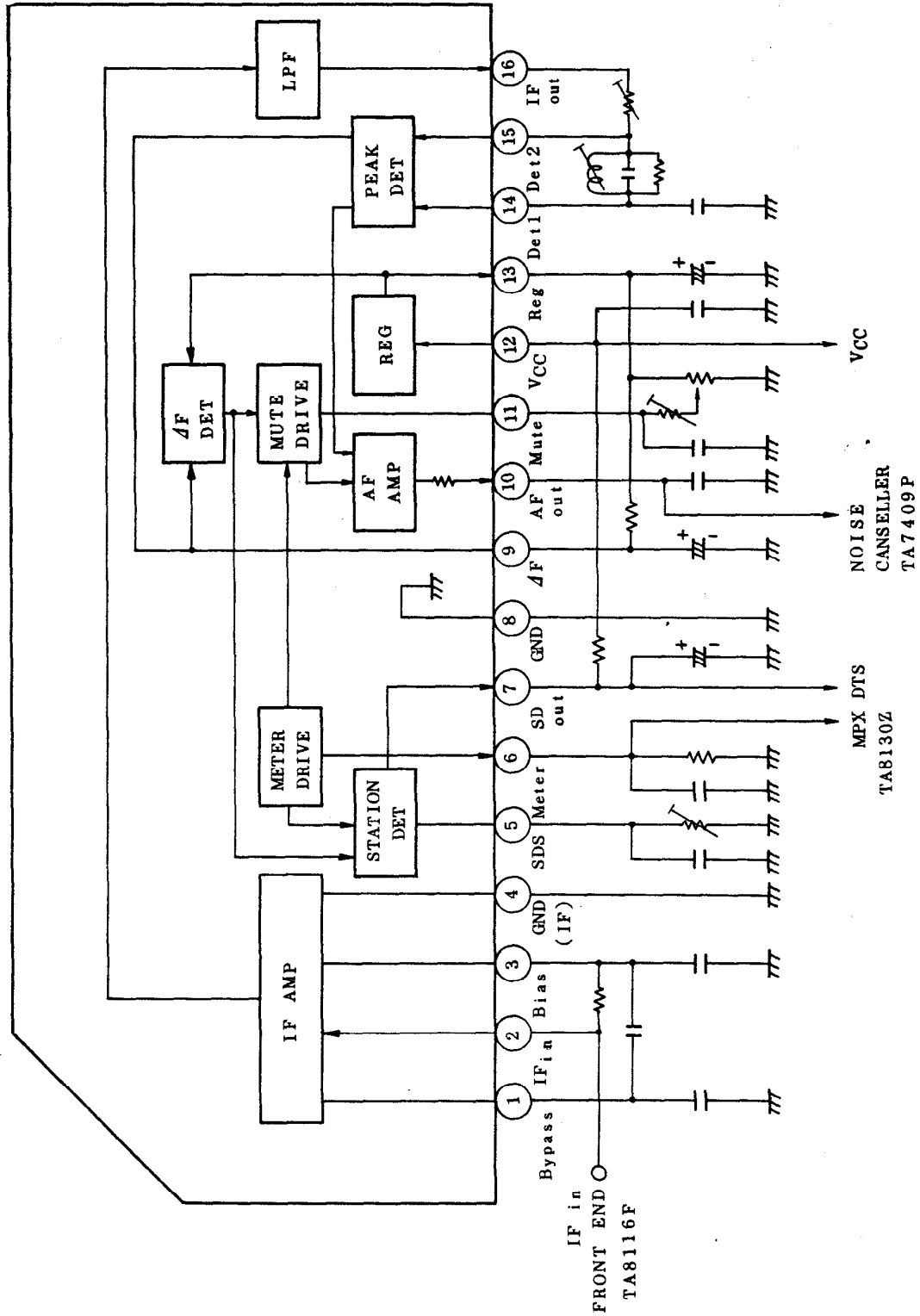

TA8129Z-2

1993-4-9

TOSHIBA CORPORATION

ELECTRICAL CHARACTERISTICS

(Unless otherwise specified,  $V_{CC}=8.5V$ ,  $f_i=10.7MHz$ ,  $Dev=\pm 75kHz$ ,  $f_m=400Hz$ ,  $V_i=80dB\mu$ ,  
SW1=on(Mute off),  $T_a=25^\circ C$ )

CHARACTERISTIC	SYMBOL	TEST CIR-CUIT	TEST CONDITION	MIN.	TYP.	MAX.	UNIT	
Quiescent Current	$I_{CCQ}$		$V_i=0$ , SW1=off	10	15	21.5	mA	
Limiting Sensitivity	$V_i(lim)$			-	33	35	dB $\mu$	
Detection Output	$V_{OD}$			350	450	550	mV <sub>rms</sub>	
Total Harmonic Distortion Ratio	THD		$Dev=\pm 22.5kHz$	-	0.06	0.5	%	
Signal to Noise Ratio	S/N			71	78	-	dB	
AM Rejection Ratio	AMR		AM=30%	46	55	-	dB	
Signal Meter Output	VSM1		$V_i=0dB\mu$	-	0	0.3	V	
	VSM2		$V_i=50dB\mu$	0.5	1.5	2.5		
	VSM3		$V_i=70dB\mu$	2.6	3.8	5.1		
	VSM4		$V_i=100dB\mu$	5.4	6.5	6.8		
Soft Muting Attenuation	ATT1		$V_i=80dB\mu \rightarrow 0dB\mu$	SW1=off	45	60	76	dB
Detuning Attenuation	ATT2		$\Delta f=\pm 200kHz$		47	55	66	dB
Station Detection Sensitivity	VSS		At the point of $V_{SD}=L \rightarrow H$	35	50	65	dB $\mu$	
Station Detection Band	BW(S)			60	100	170	kHz	
Muting Band	BW(M)		At the point of $V_{OD}=-3dB$	SW1=off	80	150	220	kHz

TEST CIRCUIT

T1 MISUMI NT6132-6

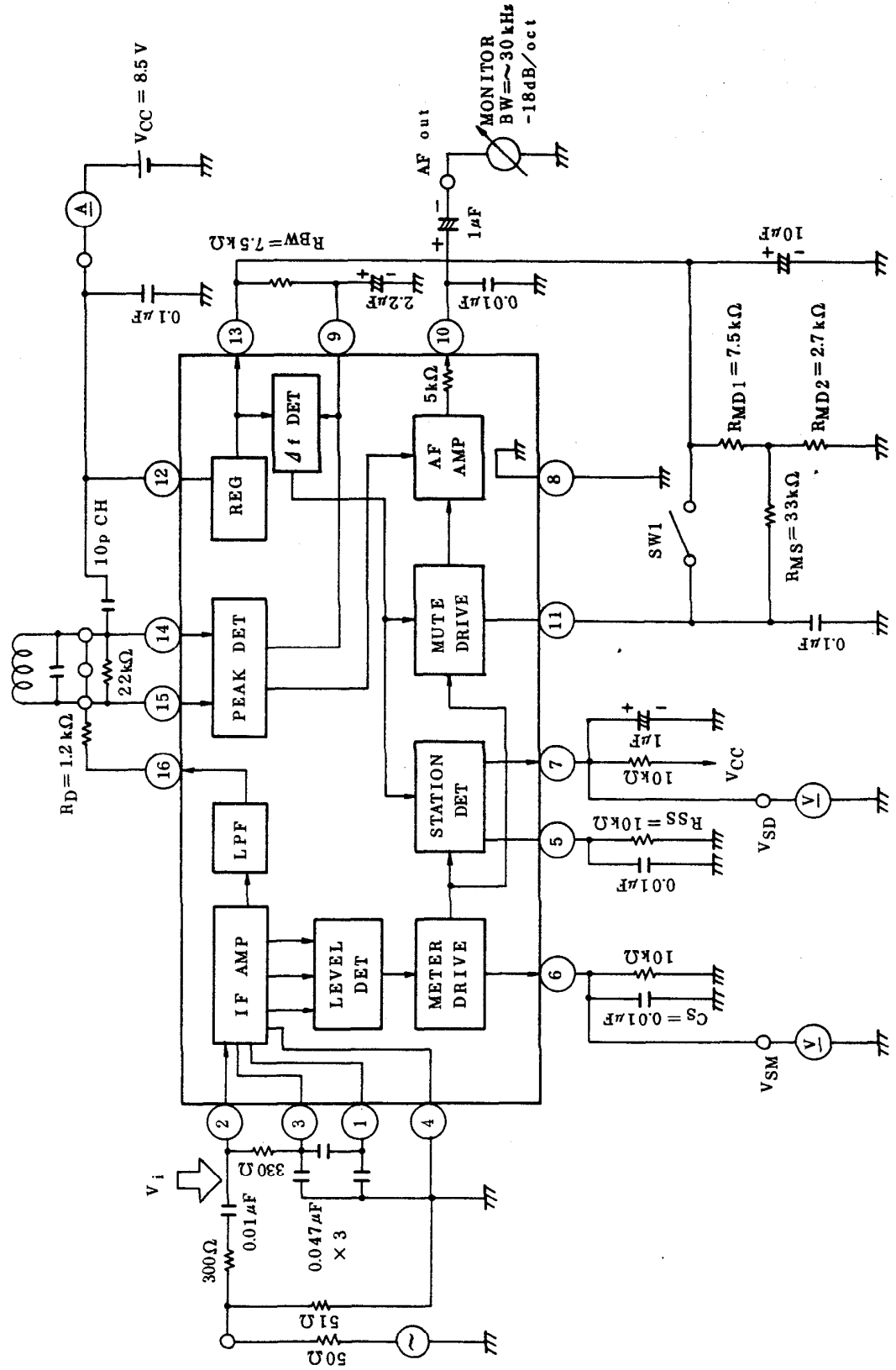

TA8129Z-4

1993-4-9

TOSHIBA CORPORATION

### DESCRIPTION OF TERMINALS

(Terminal voltage shows the value at  $V_{CC}=8.5V$ ,  $T_a=25^{\circ}C$ , and non-signal in measuring circuit.)

PIN No.	TERMINAL NAME	TERMINAL VOLTAGE (V)	INTERNAL EQUIVALENT CIRCUIT (Resistance and capacity show the typical value)	CONTENTS
1	Bypass	3.0		IF Amplifier Bypass
2	IF in	3.0		IF Amplifier Input
3	Bias	3.0		IF Amplifier Bias
4	GND(IF)	0	-	IF Amplifier GND
5	SD · S	0		Setting of Station Detection Sensitivity
6	Meter	0		Signal Meter Output

TA8129Z-5

1993-4-9

TOSHIBA CORPORATION

DESCRIPTION OF TERMINALS

(Terminal voltage shows the value at  $V_{CC}=8.5V$ ,  $T_a=25^\circ C$ , and non-signal in measuring circuit.)

PIN No.	TERMINAL NAME	TERMINAL VOLTAGE (V)	INTERNAL EQUIVALENT CIRCUIT (Resistance and capacity show the typical value)	CONTENTS
7	SD out	8.5		Station Detection Output
8	GND	0		GND Except IF Amplifier
9	$\Delta f$	4.8		S Curve ( $\Delta f$ ) Detection
10	AF out	4.8		Audio Output

DESCRIPTION OF TERMINALS

(Terminal voltage shows the value at  $V_{CC}=8.5V$ ,  $T_a=25^\circ C$ , and non-signal in measuring circuit.)

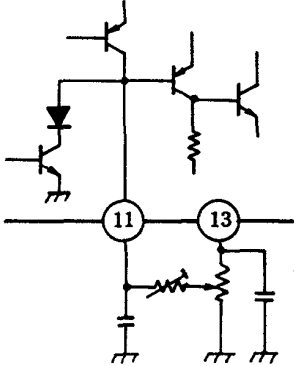
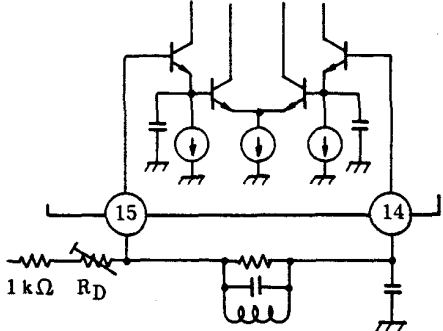
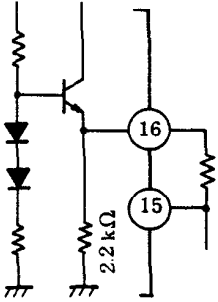
PIN No.	TERMINAL NAME	TERMINAL VOLTAGE (V)	INTERNAL EQUIVALENT CIRCUIT (Resistance and capacity show the typical value)	CONTENTS
11	Mute	4.8		Setting of Soft Mute Sensitivity and Mute Amount
12	VCC	8.5	-	Power Supply
13	Reg	4.8	Refer to items of 9 pin and 10 pin	Constant Voltage Source
14	Det1	2.4		Peak Detection Demodulation Input. THD at $\Delta f=\pm 75kHz$ , $f_m=400Hz$ can be adjusted to about 0.05% by adjusting RD(500 $\Omega$ VR).
15	Det2			In case of making into the fixed resistance, 1.2k $\Omega$ becomes the typical value.
16	IF out	2.4		IF Output

TA8129Z-7

1993-4-9

TOSHIBA CORPORATION

DIFFERENTIAL DETECTION

The differential peak detection system means a system for detecting the variation of voltages of  $e_1$  and  $e_2$  when the input frequency is varied and amplified the DC voltage by a differential amplifier to take out the detection output.

In figure 2, the level of  $e_1$  and  $e_2$  for the input frequency is shown, the point where  $e_1$  becomes minimum is the point where the impedance  $Z$  viewed from the point  $e_1$  becomes minimum and the impedance  $Z_1$  is expressed by the following equation,

$$Z_1 = \frac{1+S^2L(C_1+C_2)}{SC^2(1+S^2LC_1)} \dots\dots (1)$$

(Where,  $S=j\omega$ )

and  $f_L$  is expressed by the equation (2).

$$f_L = \frac{1}{2\pi\sqrt{L(C_1+C_2)}} \dots\dots (2)$$

Also, the point where  $e_2$  becomes minimum is the point where  $L$  and  $C_1$  are oscillated in parallel, and  $f_H$  is expressed by the equation (3).

$$f_H = \frac{1}{2\pi\sqrt{LC_1}} \dots\dots (3)$$

Further, the inductive susceptance of  $L$  and  $C_1$  becomes  $f_0$  when it becomes 1/2 of the capacitive susceptance of  $C_2$ , and the  $f_0$  is expressed by the equation (4).

$$f_0 = \frac{1}{2\pi\sqrt{L(C_1+C_2/2)}} \dots (4)$$

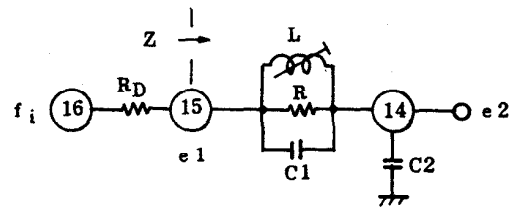

Fig. 1

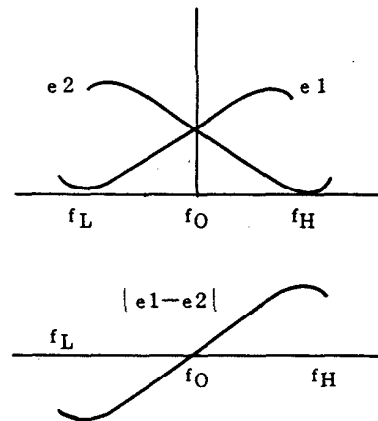

Fig. 2



The detection output is determined by the width of  $f_H$ - $f_L$ , that is, it is proportional to the ratio ( $C_1/C_2$ ) of  $C_1$  and  $C_2$ . Figure 3 shows the variation of the detection output of  $C_1=24\text{pF}$  to  $C_2$ . It is necessary to pay attention that when the detection output is reduced by decreasing  $C_1/C_2$ , the detection band is widened and S/N is somewhat lowered, therefore, for reducing the detection output holding a high S/N, and R to adjust the output.

In a conventional quadrature detection, a double tuning coil is required for obtaining a low distortion factor, but as the result, the cost is increased and adjustment is troublesome (it is fairly difficult to make  $f_0$  coincide with the minimum value of distortion).

In the TA8129Z,  $f_0$  adjustment can be preformed by coil and distortion adjustment by  $R_D$ , and cost can be reduced and the adjustment time can be shortened.

When making  $R_D$  a fixed resistance,  $R_D=1.2\text{k}\Omega$  is typical for the minimum value of distortion (under the condition of measuring circuit).

As described above, the linearity (distortion) of S curve is determined by the  $R_D$  value. However, on the other hand, it is necessary to vary the  $R_D$  value so as to obtain the minimum value of distortion by the value of  $C_1$  and  $C_2$  and especially,  $C_2$  is most influenced.

Set  $R_2$  for  $C_1$  and  $C_2$  by referring to the graph in Figure 3.

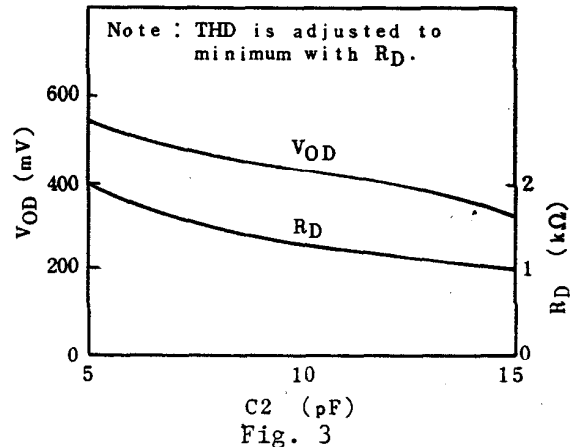

SIGNAL INTENSITY MUTING PROPERTIES

The muting circuit of the TA8129Z is constituted of an AF amplifier where gain is varied by control voltage and a control voltage generation circuit (Mute Drive) proportional to a signal meter output.

Figure 4 shows the outline of the muting circuit. The signal meter output is converted into the current by  $10k\Omega$  externally provided on 6 pin and  $1/3 I$  current is output in 11 pin in 1:1/3 current mirror circuit. This current is converted into a control voltage by RMS and VH connected outside.

The attenuation amount at non-signal is substantially determined by the value of VH since the current output in 11 pin is about 0. The VH is set by the output of the volume RMD of about  $10k\Omega$  connected to the constant voltage output ( 13 pin) of 4.8V. The variation ratio (gradient) of attenuation amount of a detection output is determined by the ratio of the variation of the 11 pin voltage VMD to the level of an input signal, that ism the variation of the signal meter voltage.

Accordingly, as RMS becomes larger, the gradient becomes steep. It is presumed that usually, the value of RMS is preferably about  $33k\Omega$ .

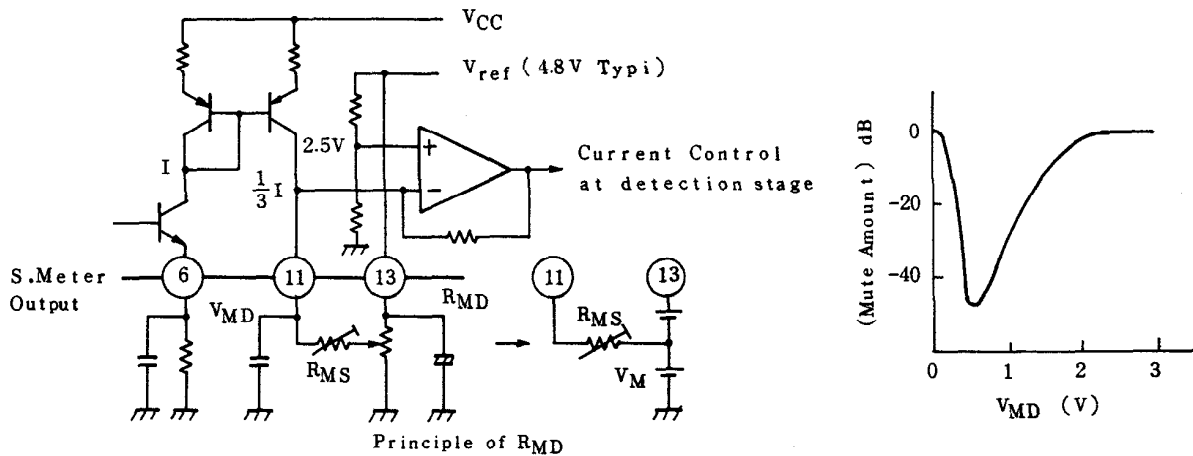

- . Attenuation amount at non-input → Adjust by RMD
- . Limiting adjustment → Adjust by RMS

Fig. 4

**MUTING PROPERTIES FOR DETUNING**

In the 9 pin of AFC terminal,  $\pm$  currents proportional to the S curve are generated. The AC component of them is smoothed by an external capacity and a DC voltage is generated in 9 pin by RBW connected between 9 pin and 13 pin. When the DC voltage generated by RBW becomes over about  $\pm 0.7V$ , the detection circuit ( $\Delta f$  Det) is operated to attenuate the AF amplifier by about 40dB.

The width of muting for detuning is determined by the resistance value of RBW, but the coil previously described is varied by setting, and set the value of RBW after setting of the coil.

The property when varying RBW on the condition of the measuring circuit is shown in Figure 5.

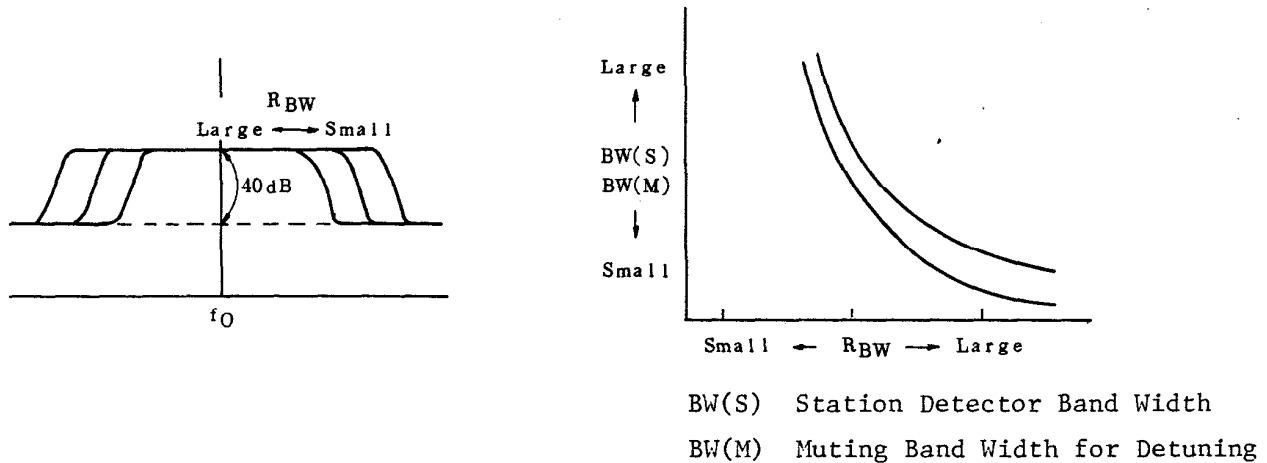

Fig. 5

**STATION DETECTOR**

The station detector (stop signal generator of DTS) detects detuning by the signal intensity of input and  $\Delta f$  detection circuit ( $\Delta f$  Det) respectively and outputs through AND circuit.

As shown in Figure 6, the signal meter output is converted into the current I by the  $10k\Omega$  connected to 6 pin and outputs the current I in 5 pin by a current mirror circuit.

This current is converted to -input of the comparator where 1V is added to +input. Therefore, the stop signal sensitivity can be adjusted by varying the value of the RSS connected to 5 pin.

Also, the variable width of the stop signal sensitivity is set widely as about  $40\text{dB}\mu$  by IF input voltage (when  $R_{SS}=2\text{k}\Omega\sim 10\text{k}\Omega$ ). The band width is varied by RBW shown in Figure 5.

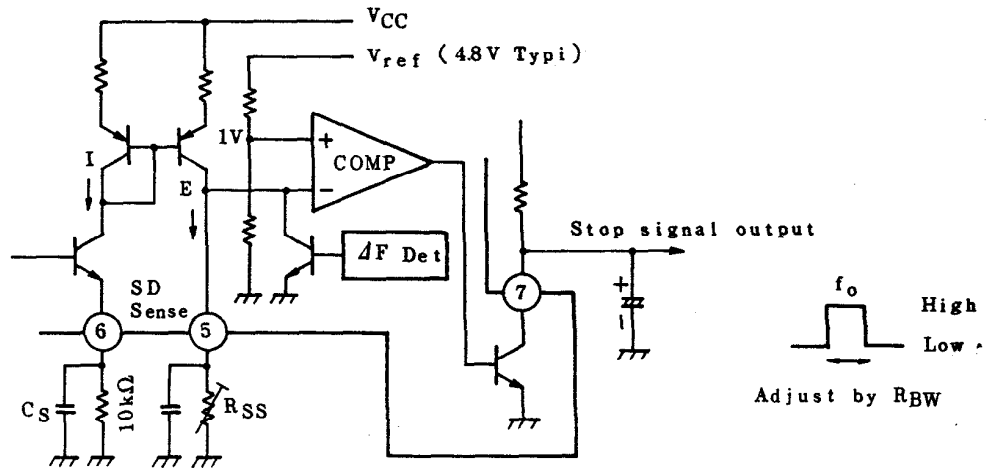

ADJUSTMENT METHOD OF TA8129Z

- . Apply the signal of 10.7MHz, 80dB $\mu$  to input.
- . Connect a voltmeter between 9 pin and 13 pin.
- . Adjust T1 and set the indication of the voltmeter to about 0V.
- . Adjust RD so that the detection distortion becomes minimum.  
(When RD is a variable resistance.)

PRECAUTION

- . When the capacity value of the by-pass capacitor  $C_S$  connected to 6 pin of meter output is fairly large, the audio signal corresponding to AM wave flows and the AMR properties are deteriorated. Use at under  $0.01\mu\text{F}$ .

TA8129Z-12
1993-4-9
<b>TOSHIBA CORPORATION</b>

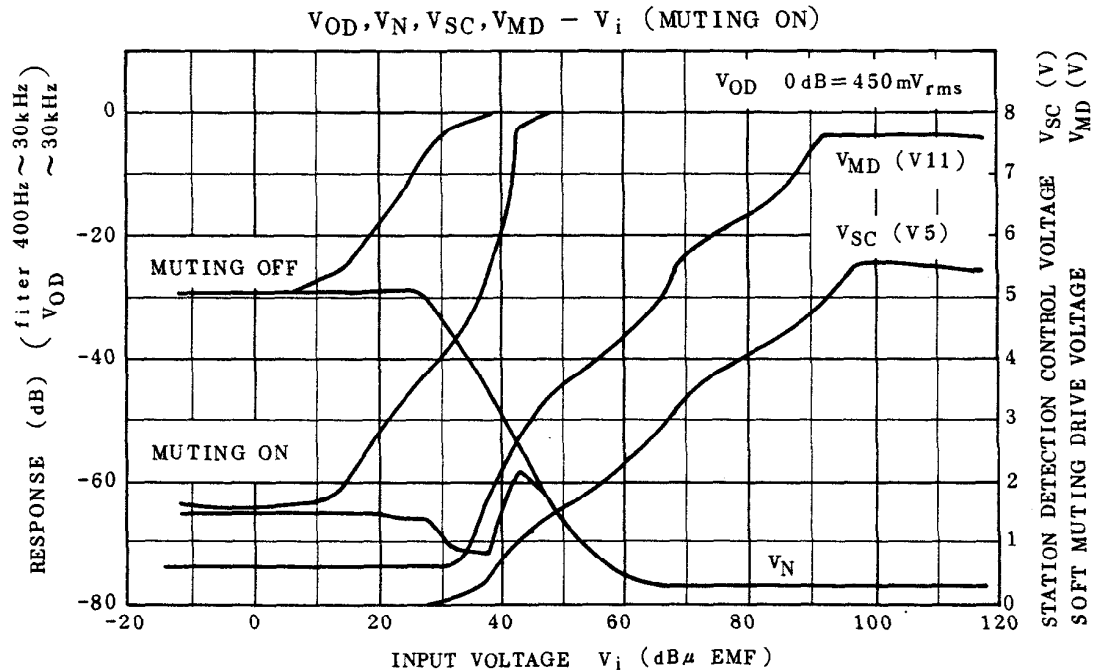
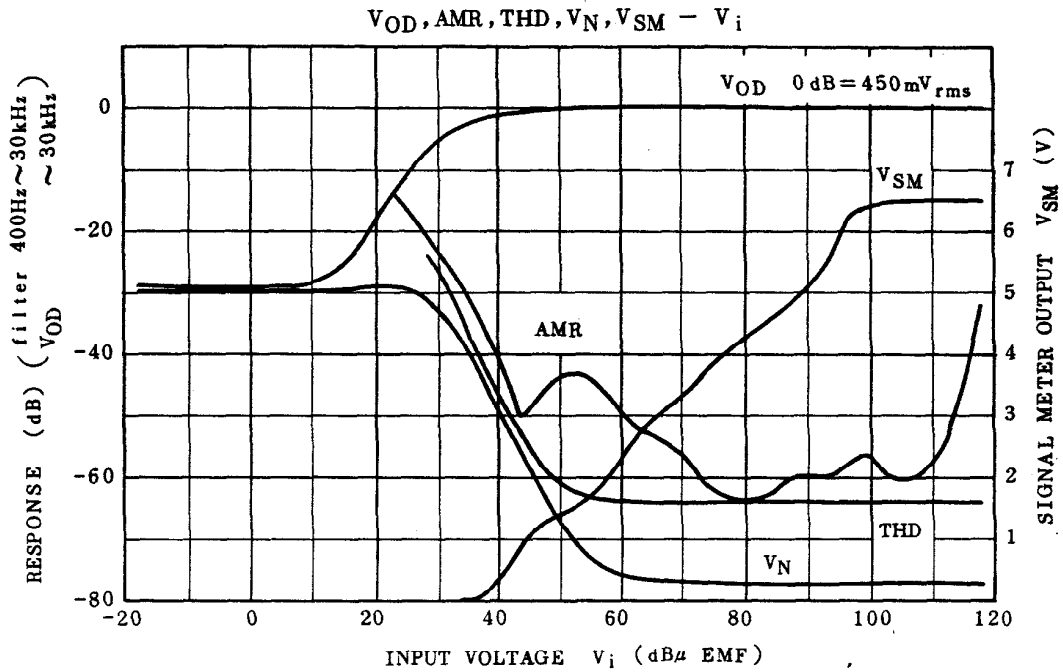

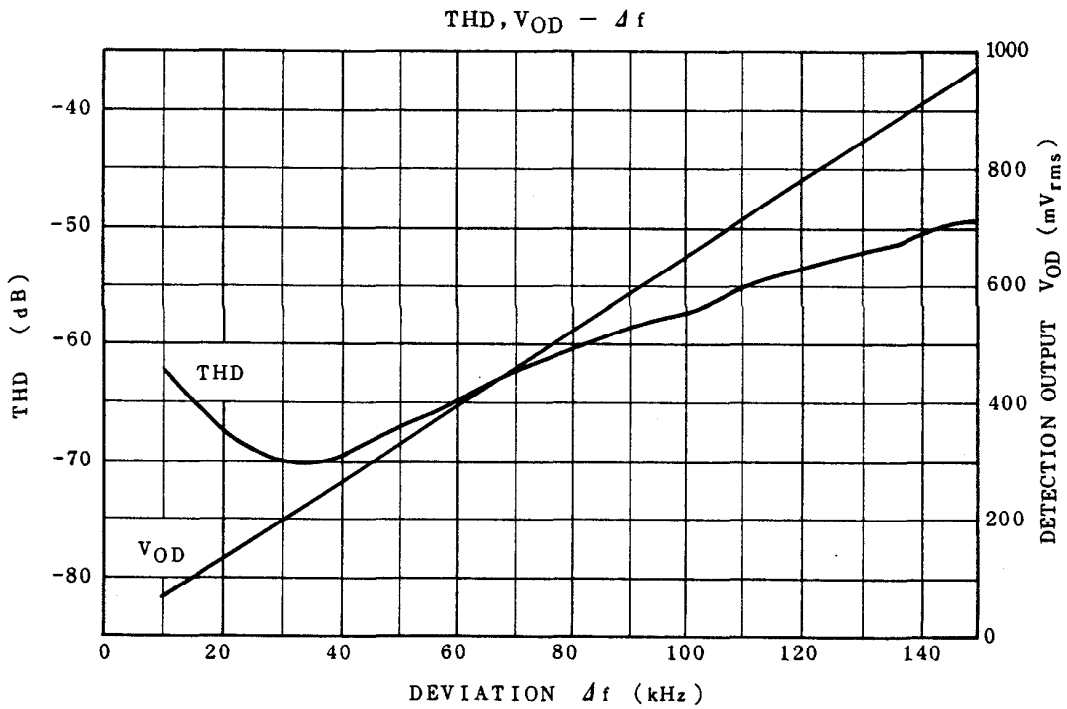
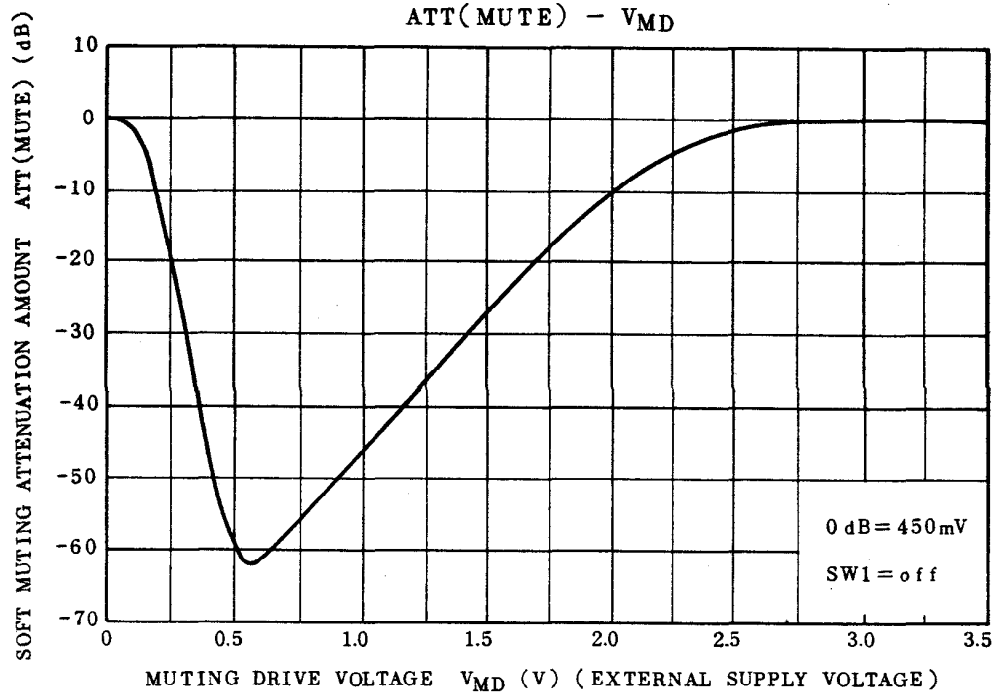

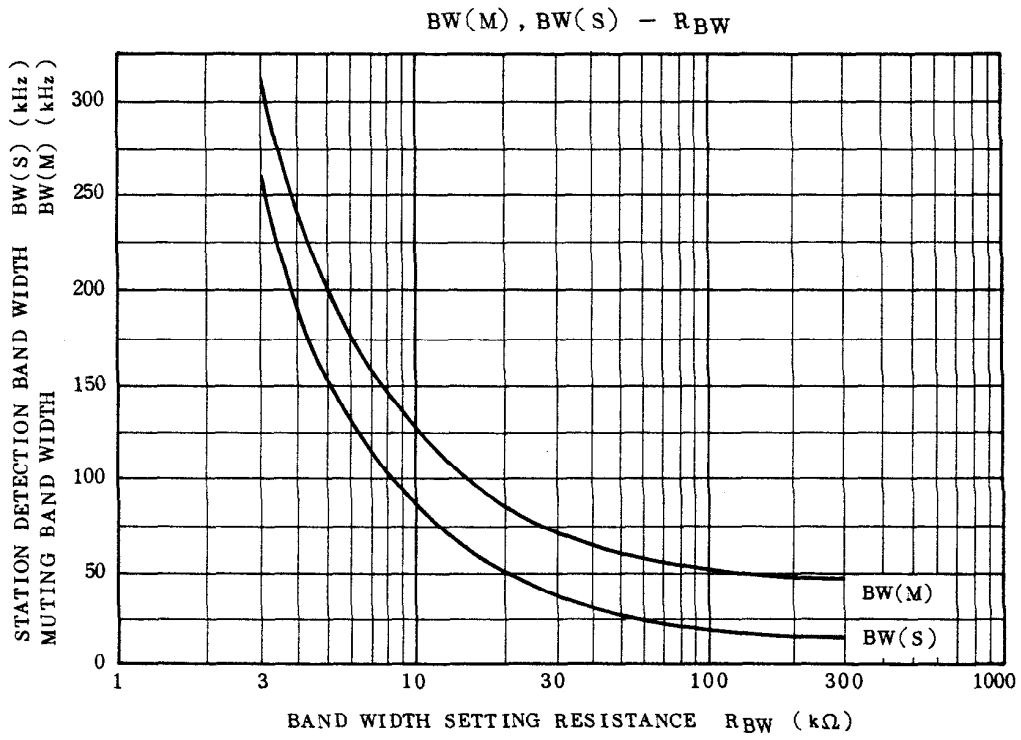
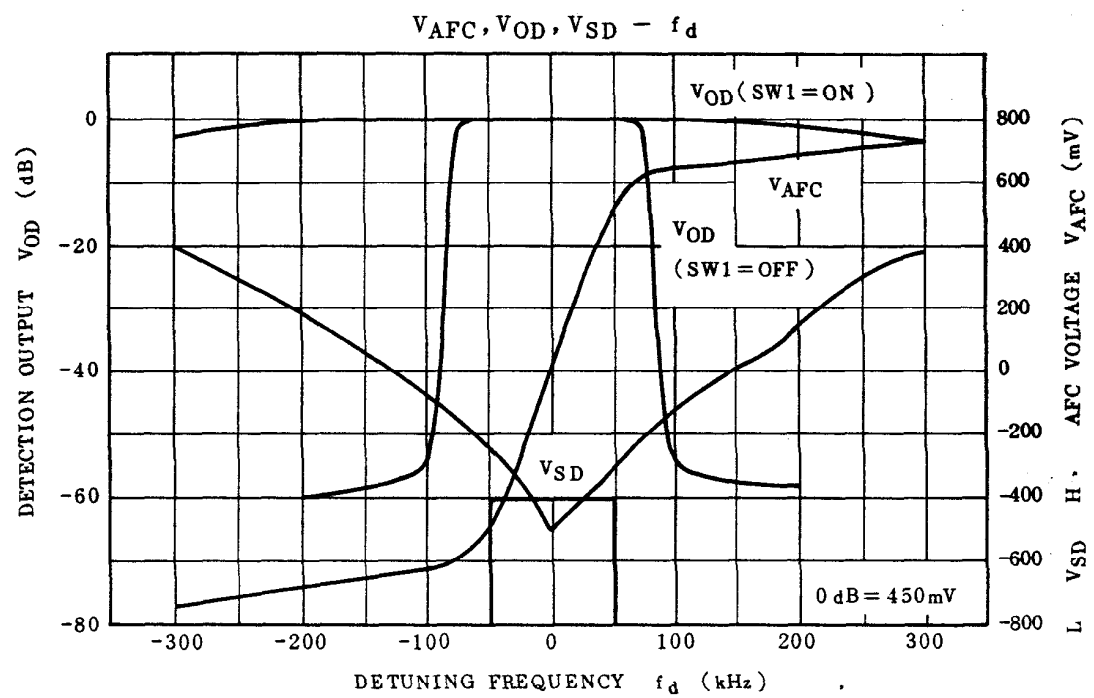

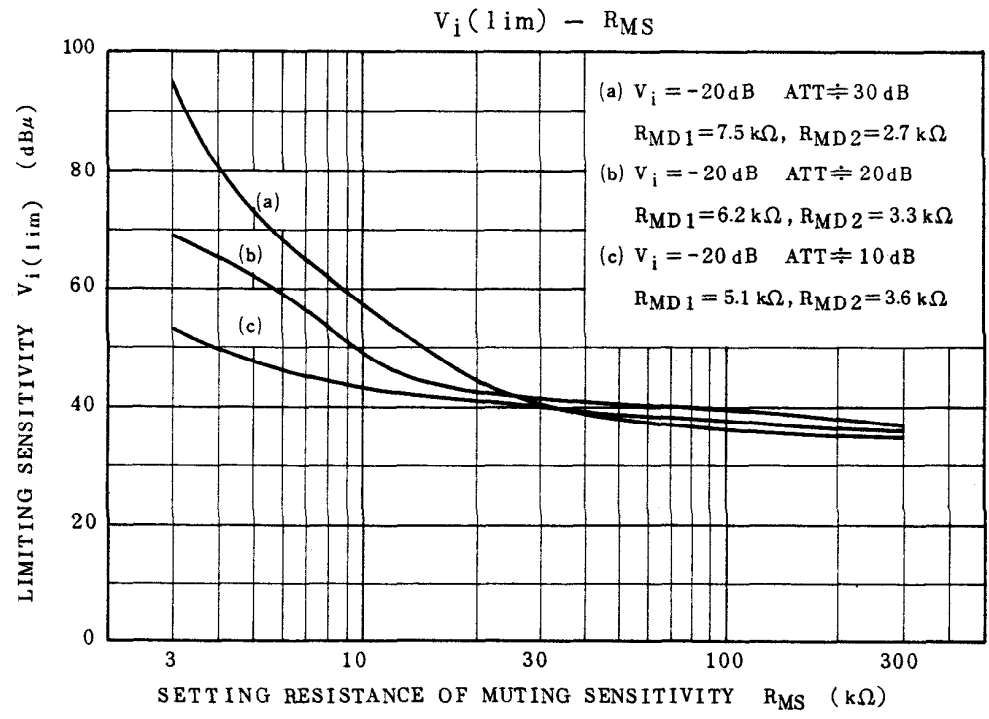
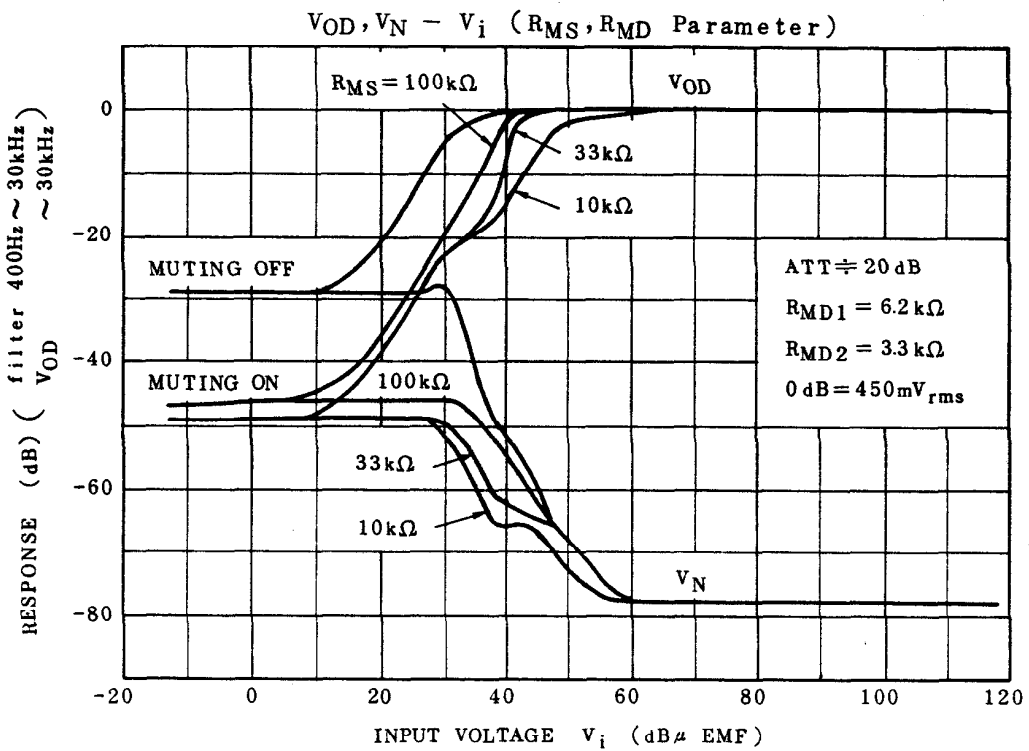



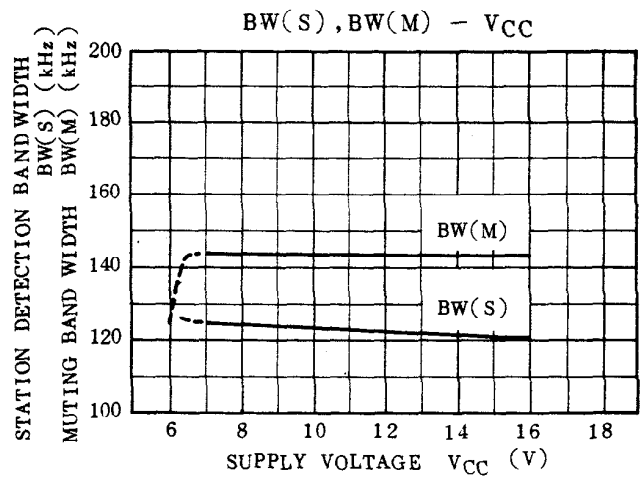
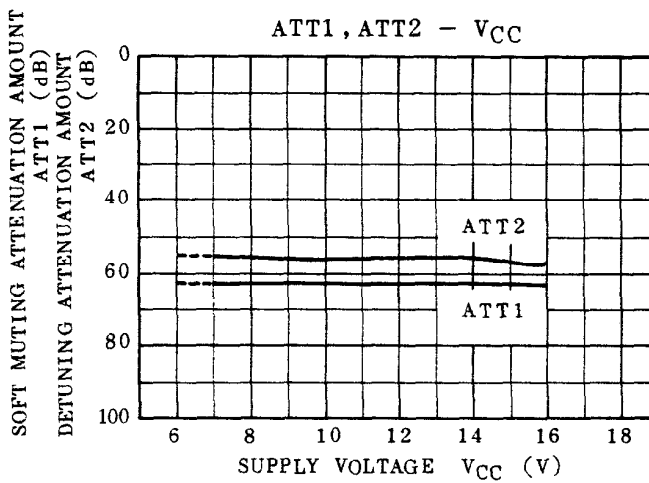
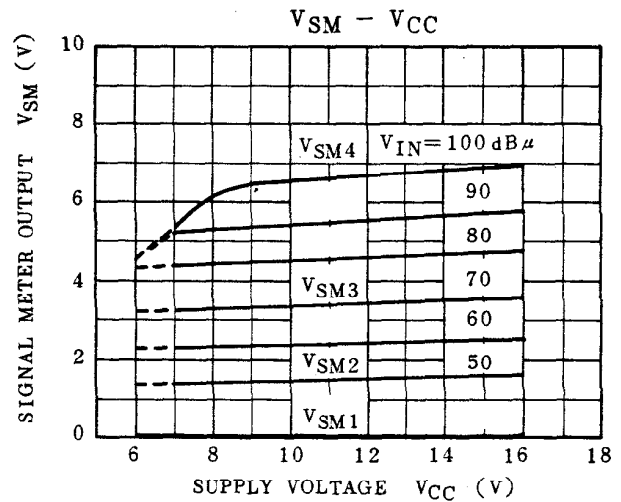
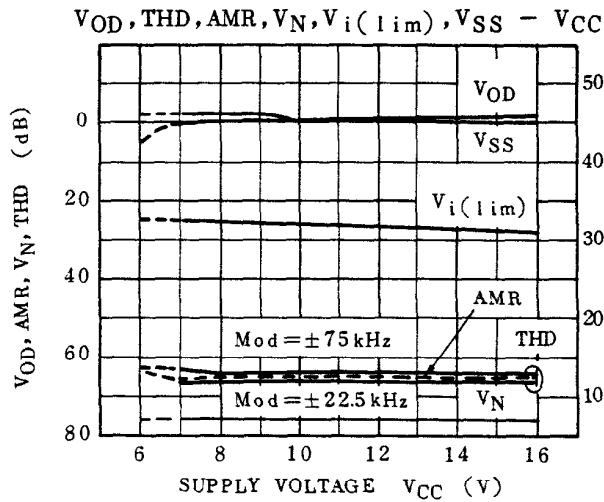
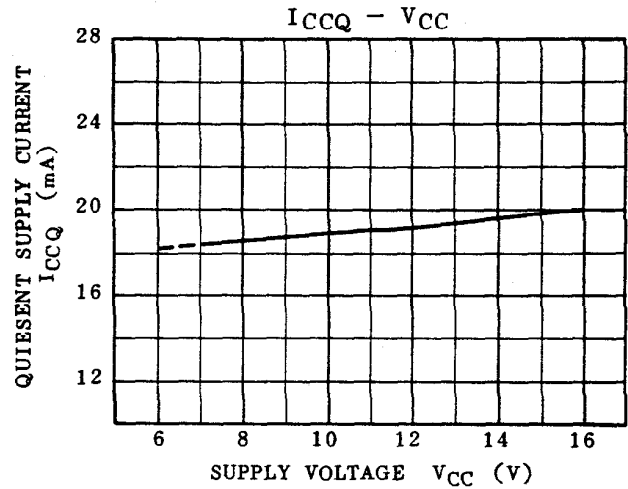
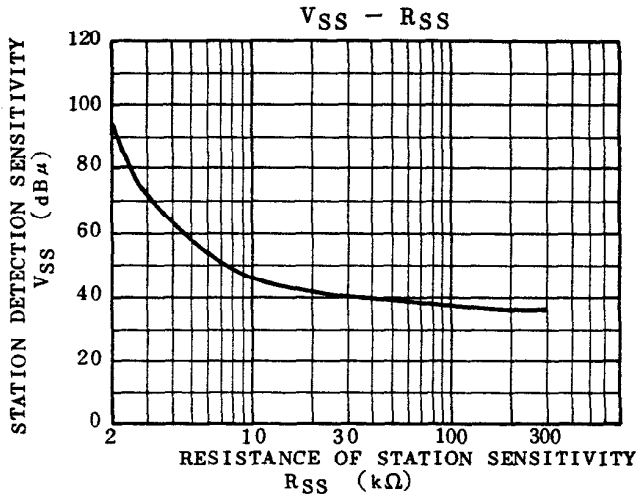

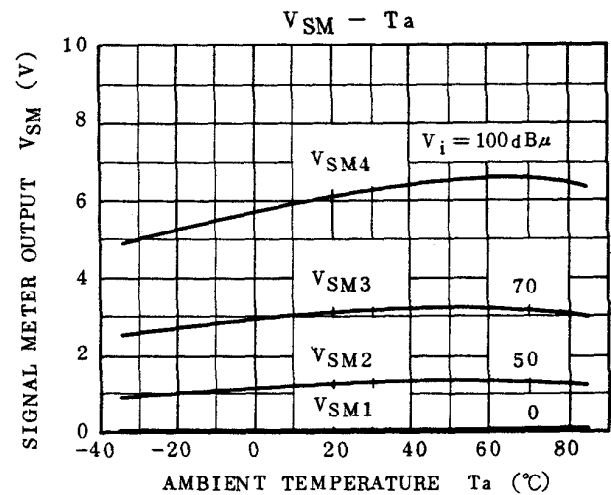
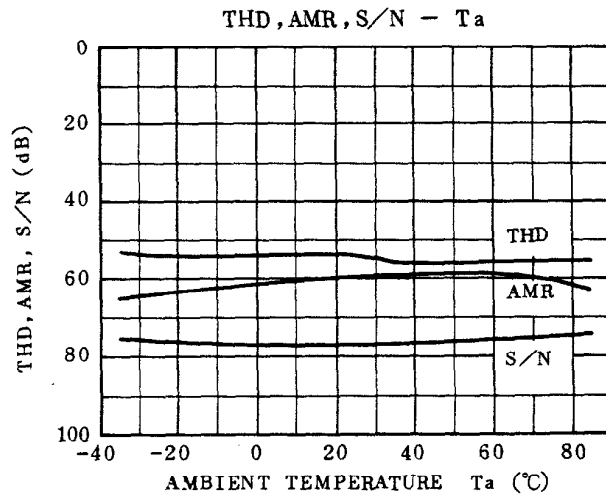
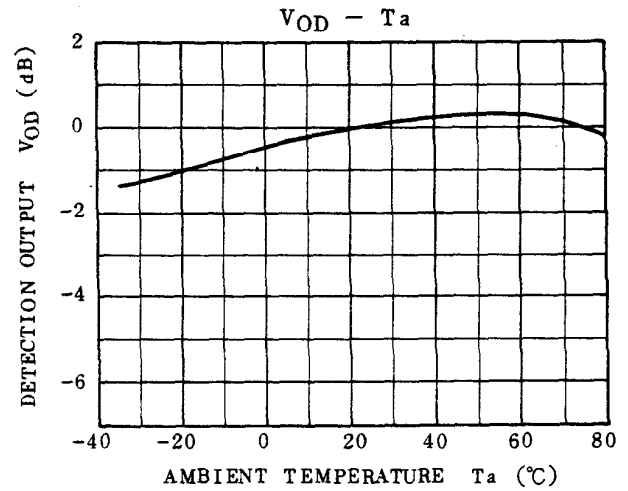
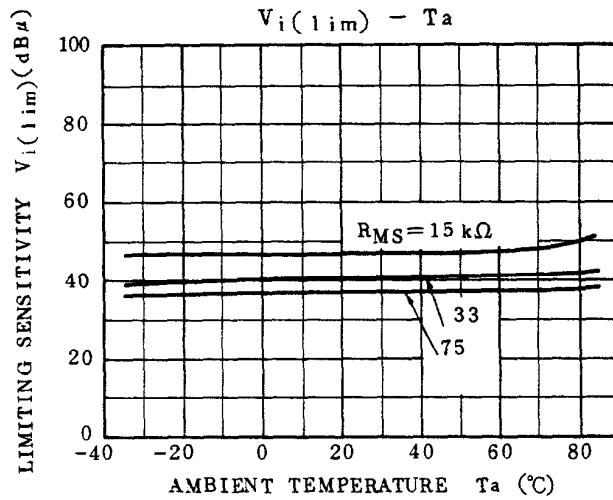
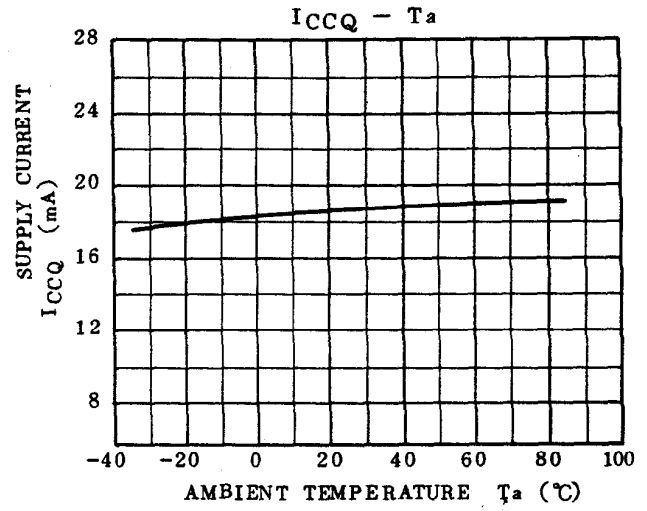
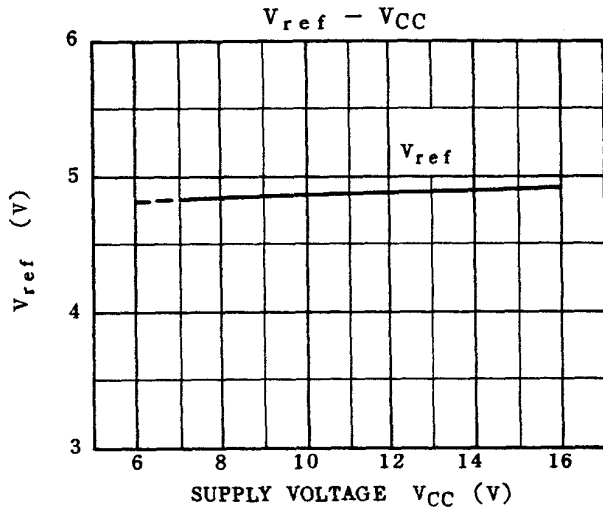

TA8129Z-18

1993-4-9

TOSHIBA CORPORATION

ATT1, ATT2 - Ta

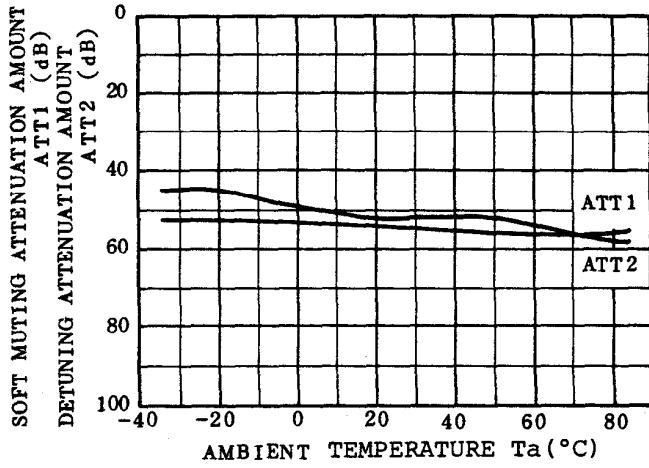

VSS - Ta

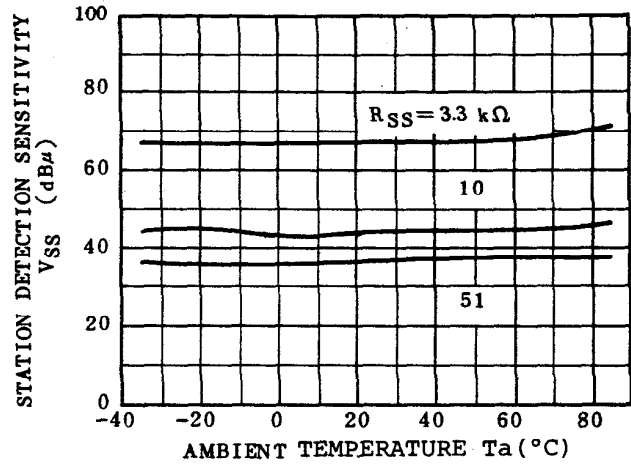

BW(M) - Ta

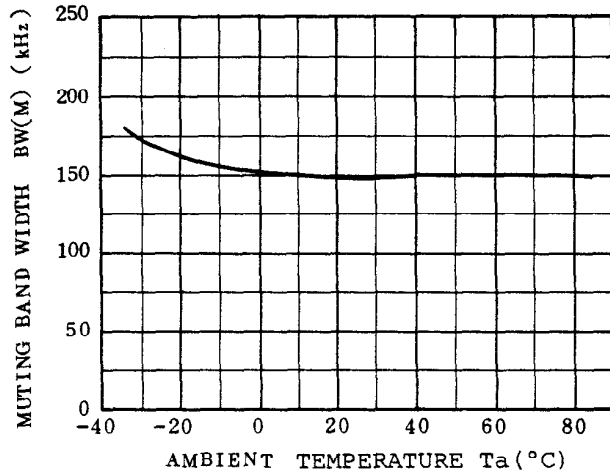

BW(S) - Ta

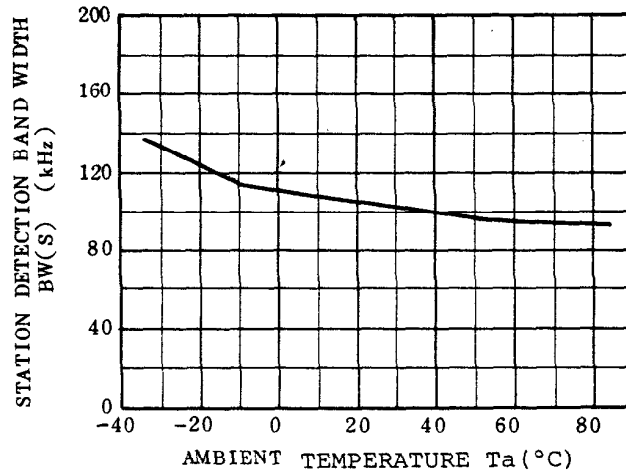



APPLICATION CIRCUIT  
FRONT END (TA8116F)

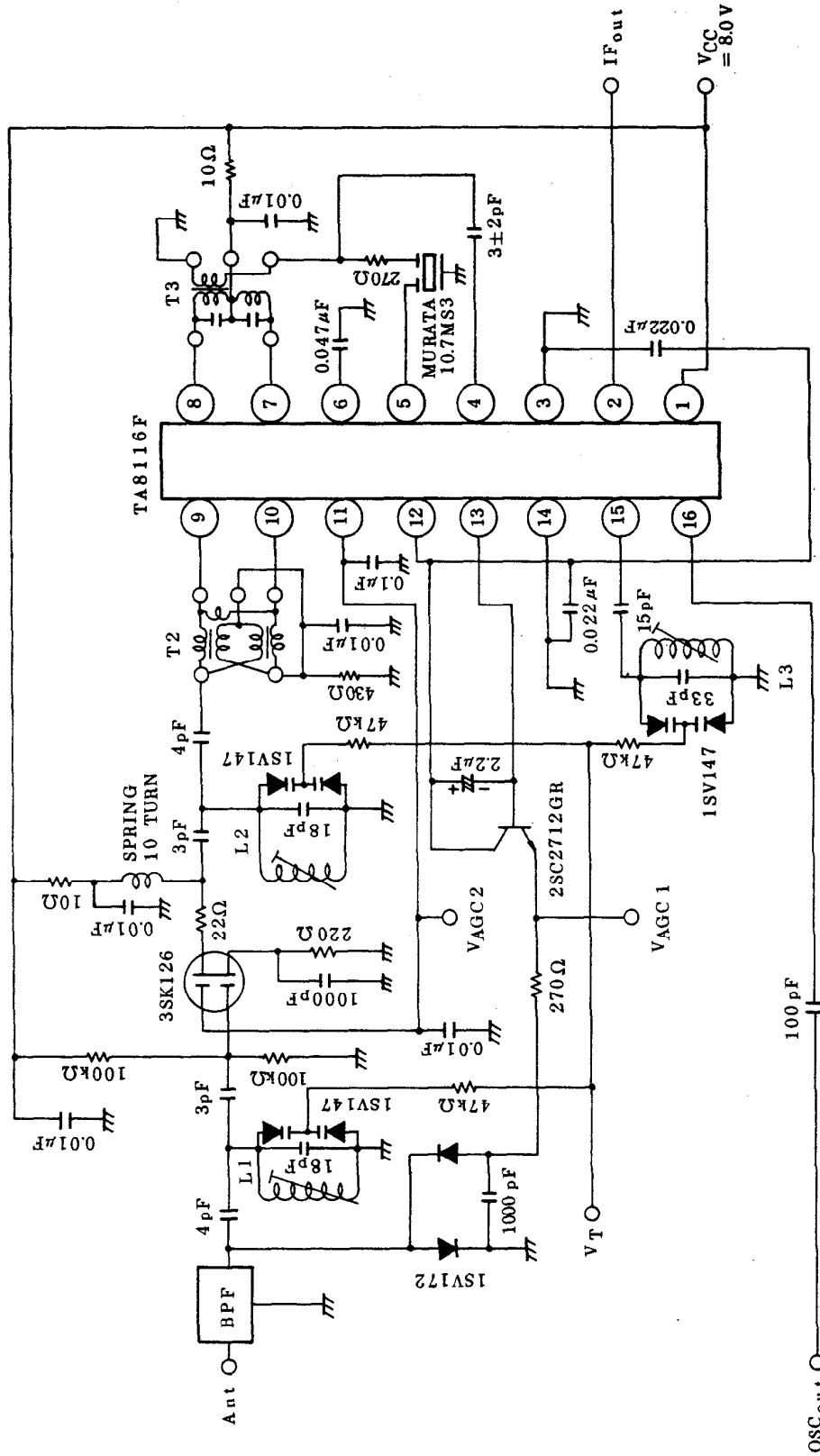

TA8129Z-21

1993-4-9

TOSHIBA CORPORATION

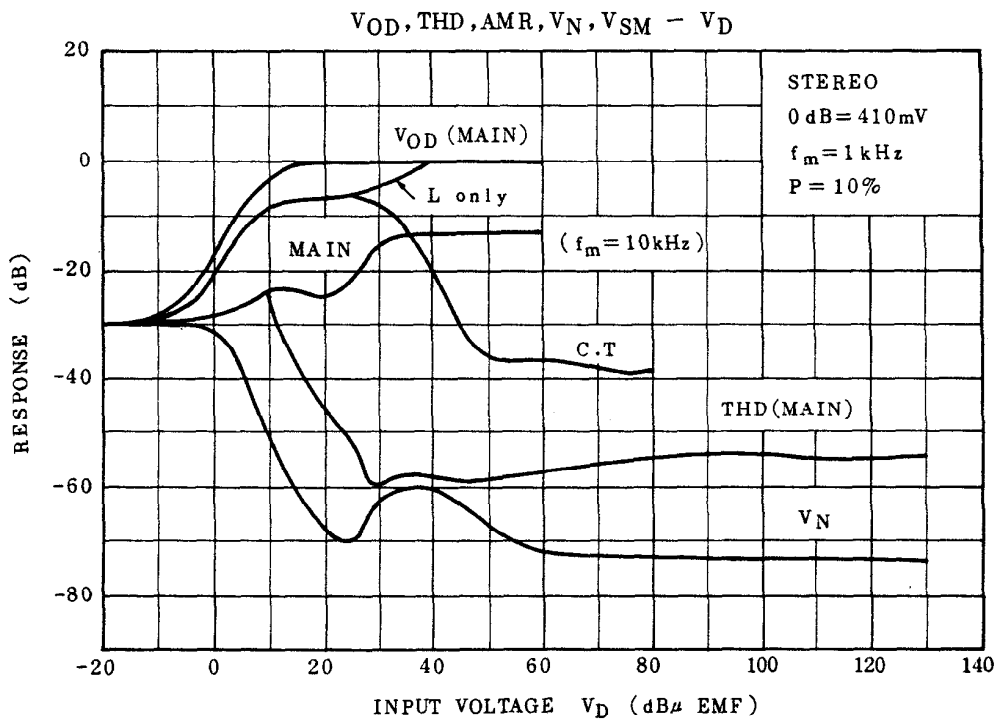
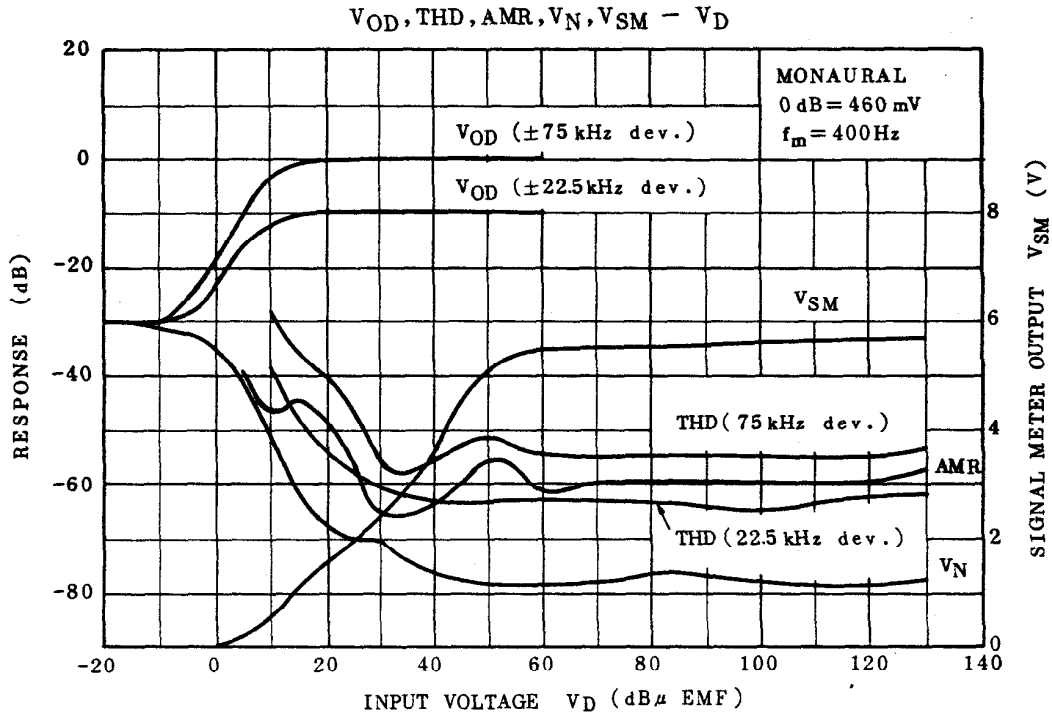

TA8129Z-22

1993-4-9

TOSHIBA CORPORATION

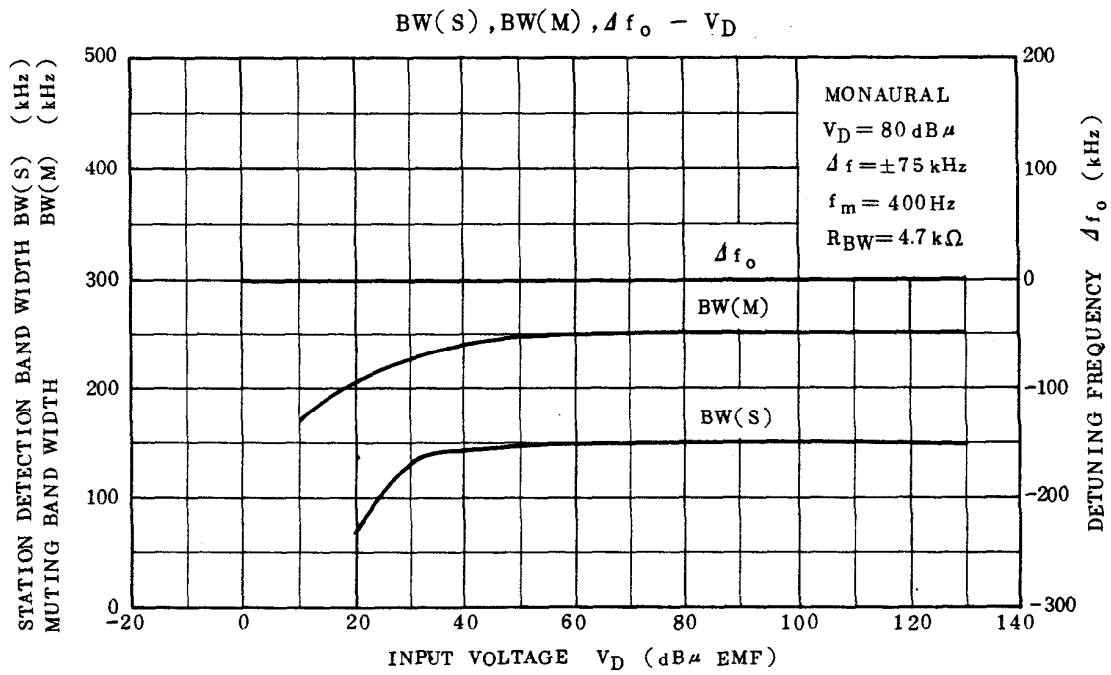
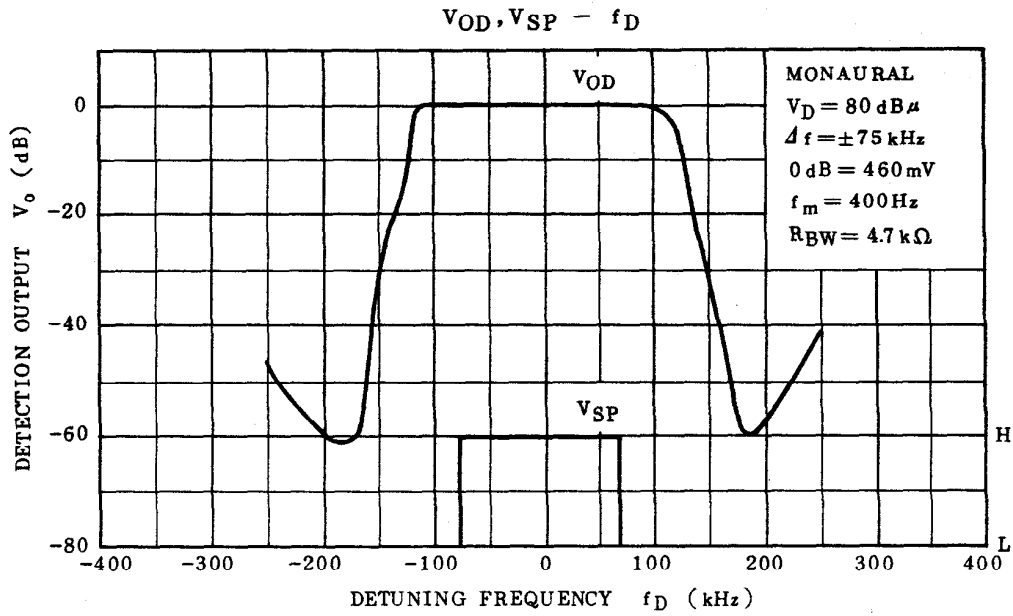

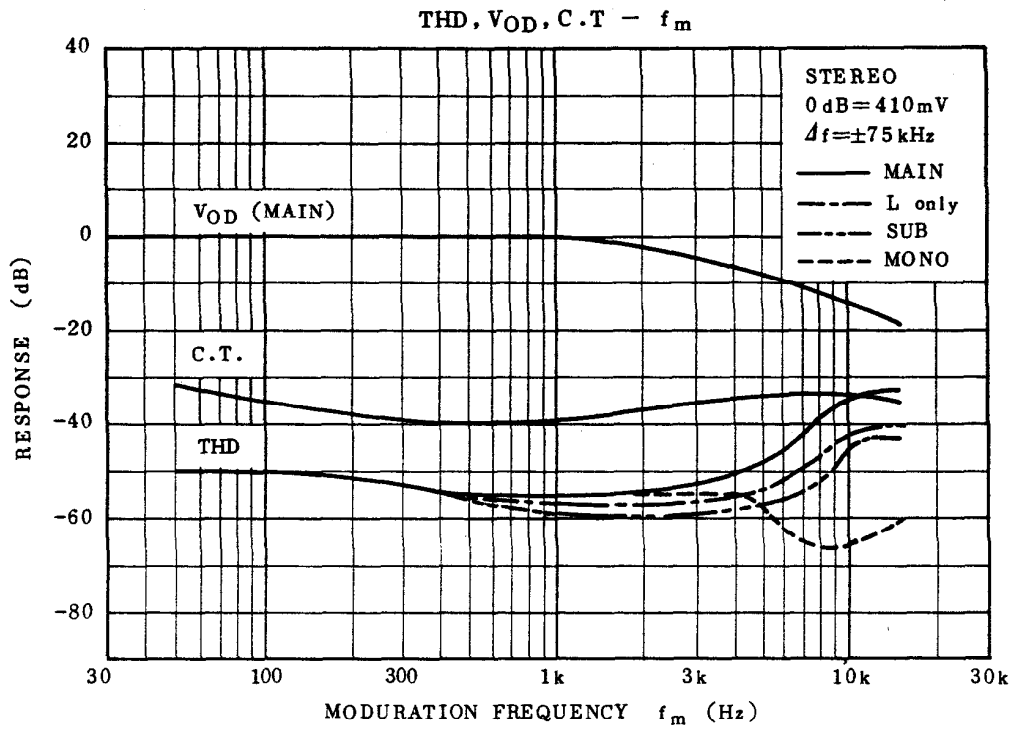



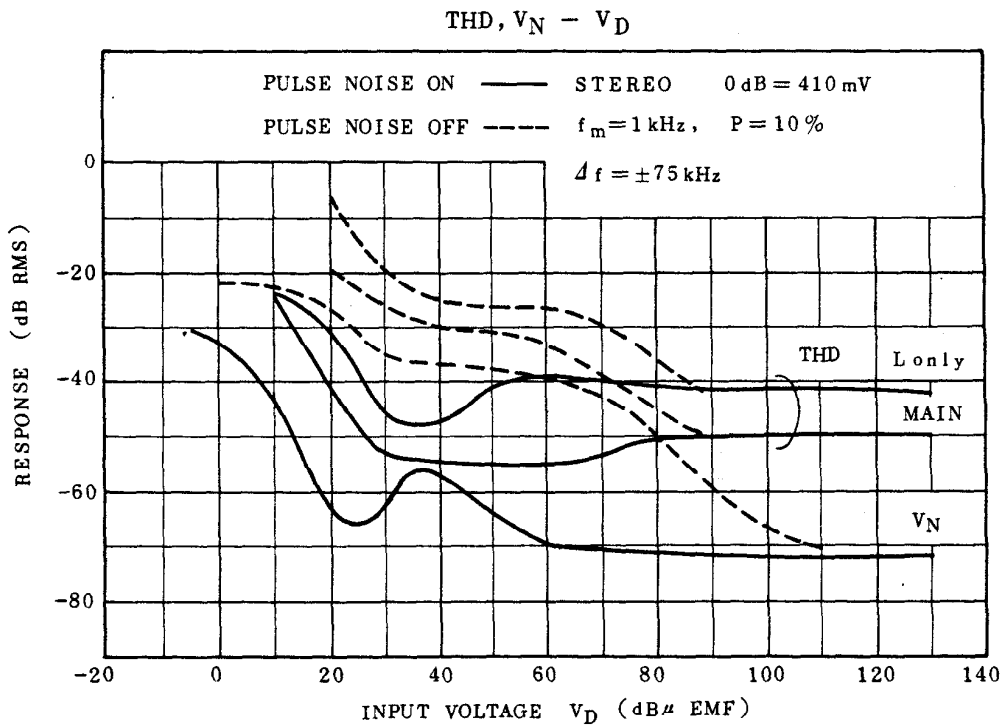
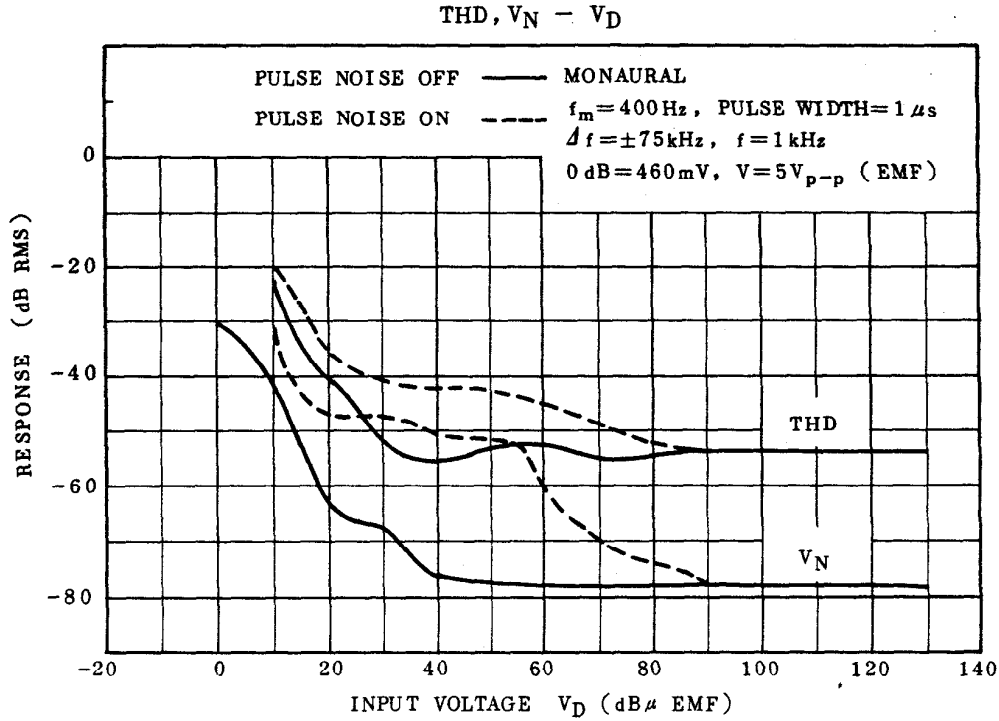

TA8129Z-25

1993-4-9

TOSHIBA CORPORATION

#### DATA OF COILS (TYP.)

COIL No.	STAGE	TEST FREQUENCY (MHz)	L (μH)	C <sub>0</sub> (pF)	Q <sub>0</sub>	TURN				WIRE (mm)	NOTE
						1-2	2-3	1-3	4-6		
T1	Det	10.7	-	24 (pH)	40	-	-	-	36	0.07 UEW	MT6132-6 MITSUMI
T1	Det	10.7	-	24	40	-	-	-	40	0.07 2 UEW	7KL-2816 TOKO
T2	Mix	10.7									2225-015 SUMIDA
T3	Mix	10.7		33 × 2	45 ≅			2	21	0.12 UEW	47K-123 SUMIDA
T3	Mix	10.7		33 × 2	60 ≅			21	8	0.07 2 UEW	388AH-1087FTM TOKO
L1	Ant							$\frac{1}{4}$			0258-000-021 SUMIDA
L2	RF							$\frac{1}{4}$			
L3	OSC							$\frac{3}{4}$			0258-000-020 SUMIDA

#### CR MODULE DN1360B (MURATA)

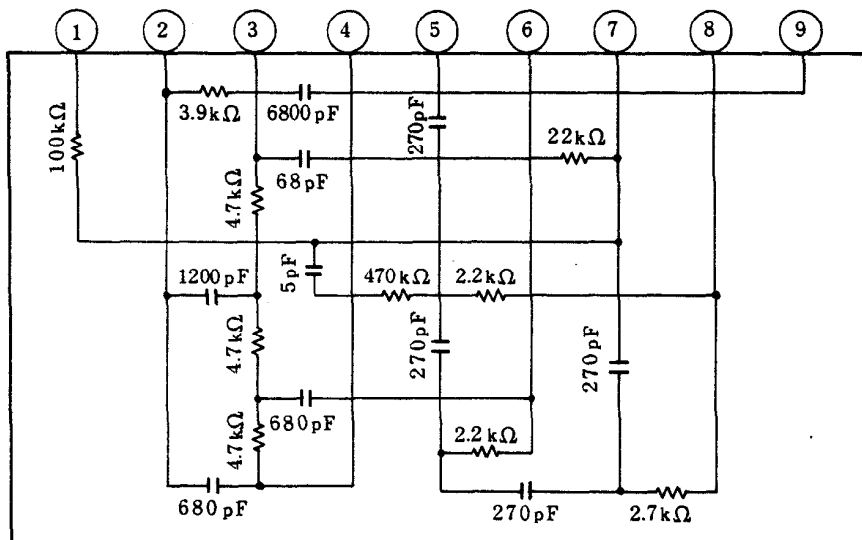

TA8129Z-26

1993-4-9

TOSHIBA CORPORATION

OUTLINE DRAWING  
 ZIP16-P

Unit in mm

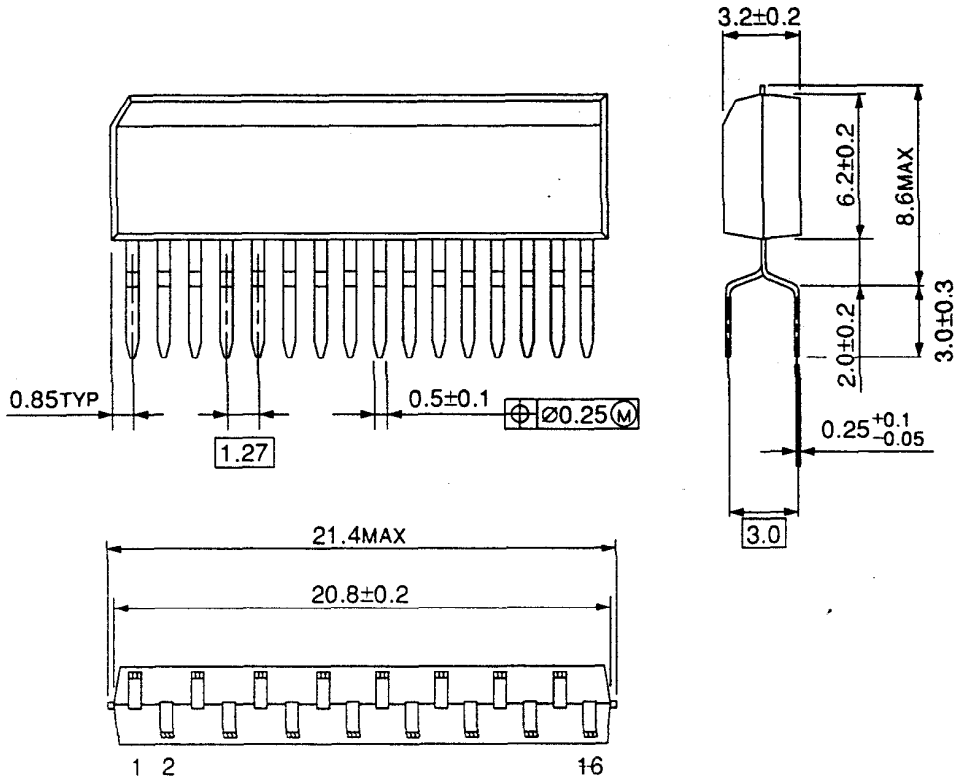

Weight : 0.99g(Typ.)