

TOSHIBA Bipolar Linear Integrated Circuit Silicon Monolithic

# TA7368PG, TA7368FG

## Audio Power Amplifier

The TA7368PG and TA7368FG are suitable for the audio power amplifier of portable cassette tape recorder and radio.

### Features

- Very few external parts (only three capacitors)
- Low quiescent current:  $I_{CCQ} = 6.6\text{mA}$  (typ.) ( $V_{CC} = 6\text{V}$ )
- Output power  
 TA7368PG  
 :  $P_{out} = 720\text{mW}$  (typ.) ( $V_{CC} = 6\text{V}$ ,  $R_L = 4\Omega$ , THD = 10%)  
 TA7368PG / FG  
 :  $P_{out} = 450\text{mW}$  (typ.) ( $V_{CC} = 6\text{V}$ ,  $R_L = 8\Omega$ , THD = 10%)
- Voltage gain:  $G_V = 40\text{dB}$  (typ.)
- Operating supply voltage range:  $V_{CC} = 2\sim 10\text{V}$  ( $T_a = 25^\circ\text{C}$ )

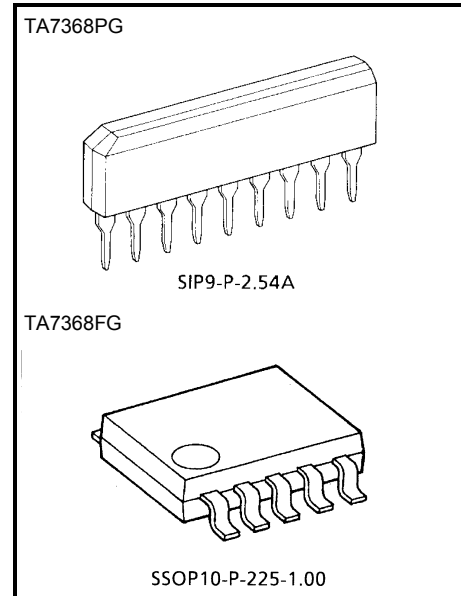

Weight  
 SIP9-P-2.54A : 0.92g (typ.)  
 SSOP10-P-225-1.00 : 0.09g (typ.)

### Block Diagram

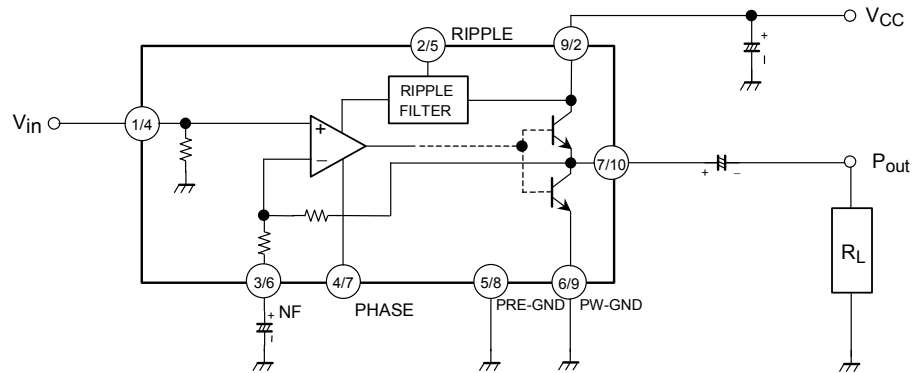

( / ) : TA7368PG / TA7368FG

## Precaution For Use And Application

### 1. Input stage

The input stage of power amplifier (equivalent circuit) is comprised of a PNP differential pair (Q<sub>2</sub> and Q<sub>3</sub>) preceded by a PNP emitter follower (Q<sub>1</sub>) which allows DC referencing of the source signal to ground. This eliminated the need for an input coupling capacitor. However, in case the brush noise of volume becomes a problem, provide serially a coupling capacitor to the input side.

### 2. Adjustment of voltage gain

The voltage gain is fixed at  $G_V \approx 40\text{dB}$  by the resistors (R<sub>4</sub> and R<sub>5</sub>) in IC, however, its reduction is possible through adding R<sub>f</sub> as shown in Figure 2. In this case, the voltage gain is obtained by the following equation.

$$G_V = 20 \log \frac{R_5 + R_4 + R_f}{R_4 + R_f}$$

It is recommended to use this IC with the voltage gain of  $G_V = 28\text{dB}$  or over.

### 3. Ripple rejection ratio

Adding CRIP, to ripple terminal 2 as shown in Figure 3, the ripple rejection ratio is improved from  $-25\text{dB}$  typ. to  $-45\text{dB}$  typ.

### 4. Power dissipation

Care should be taken to use this IC below maximum power dissipation. Because it may over absolute maximum rating depending on operating condition.

- TA7368PG  $P_D = 900\text{mW}$  ( $T_a = 25^\circ\text{C}$ )
- TA7368FG  $P_D = 400\text{mW}$  ( $T_a = 25^\circ\text{C}$ )

### 5. Phase-compensation

Small temperature coefficient and excellent frequency characteristic is needed by capacitors below.

- Oscillation preventing capacitors for power amplifier output
- Bypass capacitor for ripple filter
- Capacitor between VCC and GND

⊘ : TA7368PG / TA7368FG

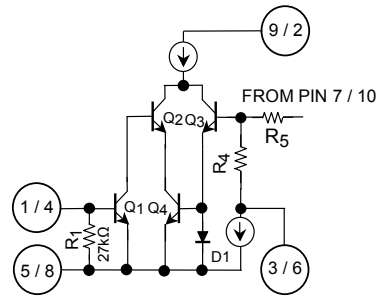

Fig.1

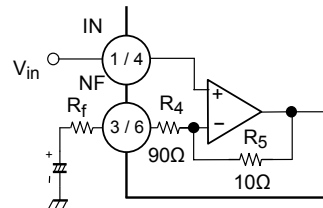

Fig.2

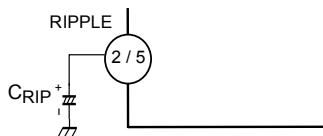

Fig.3

## Absolute Maximum Ratings (Ta = 25°C)

Characteristic	Symbol	Rating	Unit
Supply voltage	V <sub>CC</sub>	14	V
Power dissipation	TA7368PG	P <sub>D</sub> (Note)	mW
	TA7368FG		
Operating temperature	T <sub>opr</sub>	-25~75	°C
Storage temperature	T <sub>stg</sub>	-55~150	°C

(Note) Derated above Ta = 25°C in the proportion of 7.2mW / °C for TA7368PG and of 3.2mW / °C for TA7368FG.

## Electrical Characteristics For TA7368PG

(Unless otherwise specified, V<sub>CC</sub> = 6V, f = 1kHz, R<sub>g</sub> = 600Ω, R<sub>L</sub> = 4Ω, Ta = 25°C)

Characteristic	Symbol	Test Circuit	Test Condition	Min.	Typ.	Max.	Unit
Quiescent current	I <sub>CCQ</sub>	—	V <sub>CC</sub> = 3V, V <sub>in</sub> = 0	—	5.5	—	mA
			V <sub>CC</sub> = 6V, V <sub>in</sub> = 0	—	6.6	15	
			V <sub>CC</sub> = 9V, V <sub>in</sub> = 0	—	7.5	18	
Output power	P <sub>out</sub>	—	V <sub>CC</sub> = 3V, R <sub>L</sub> = 4Ω, THD = 10%	—	120	—	mW
			V <sub>CC</sub> = 6V, R <sub>L</sub> = 4Ω, THD = 10%	500	720	—	
			V <sub>CC</sub> = 6V, R <sub>L</sub> = 8Ω, THD = 10%	300	450	—	
			V <sub>CC</sub> = 9V, R <sub>L</sub> = 8Ω, THD = 10%	800	1100	—	
			V <sub>CC</sub> = 9V, R <sub>L</sub> = 16Ω, THD = 10%	450	610	—	
Total harmonic distortion	THD	—	P <sub>out</sub> = 100mW	—	0.3	1.0	%
Voltage gain	G <sub>V</sub>	—	V <sub>in</sub> = 0.5mV <sub>rms</sub>	37	40	43	dB
Output noise voltage	V <sub>no</sub>	—	R <sub>g</sub> = 10kΩ, BPF = 20Hz~20kHz	—	0.2	0.5	mV <sub>rms</sub>
Ripple rejection ratio	RR	—	f <sub>r</sub> = 100Hz, V <sub>r</sub> = 0.3V <sub>rms</sub> Without C <sub>RIP</sub>	—	25	—	dB
Input resistance	R <sub>IN</sub>	—	—	—	27	—	kΩ

## Terminal Voltage For TA7368PG

Typical Terminal Voltage at no Signal With Test Circuit. (V<sub>CC</sub> = 6V, Ta = 25°C)

[Unit: V]

Terminal no.	1	2	3	4	5	6	7	8	9
DC voltage (V)	0	2.40	0.62	0.64	0	0	2.61	NC	6.0

## Electrical Characteristic For TA7368FG

(unless otherwise specified,  $V_{CC} = 6V$ ,  $f = 1kHz$ ,  $R_g = 600\Omega$ ,  $R_L = 8\Omega$ ,  $T_a = 25^\circ C$ )

Characteristic	Symbol	Test Circuit	Test Condition	Min.	Typ.	Max.	Unit
Quiescent current	$I_{CCQ}$	—	$V_{CC} = 3V, V_{in} = 0$	—	5.5	—	mA
			$V_{CC} = 6V, V_{in} = 0$	—	6.6	15	
			$V_{CC} = 9V, V_{in} = 0$	—	7.5	18	
Output power	$P_{out}$	—	$V_{CC} = 3V, R_L = 4\Omega, THD = 10\%$	—	120	—	mW
			$V_{CC} = 6V, R_L = 8\Omega, THD = 10\%$	300	450	—	
			$V_{CC} = 9V, R_L = 16\Omega, THD = 10\%$	450	610	—	
Total harmonic distortion	THD	—	$P_{out} = 100mW$	—	0.3	1.0	%
Voltage gain	$G_V$	—	$V_{in} = 0.5mV_{rms}$	37	40	43	dB
Output noise voltage	$V_{no}$	—	$R_g = 10k\Omega, BPF = 20Hz\sim 20kHz$	—	0.2	0.5	$mV_{rms}$
Ripple rejection ratio	RR	—	$f_r = 100Hz, V_r = 0.3V_{rms}$ , Without $C_{RIP}$	—	25	—	dB
Input resistance	$R_{IN}$	—	—	—	27	—	k $\Omega$

## Terminal Voltage For TA7368FG

Typical Terminal Voltage at no Signal with Test Circuit. ( $V_{CC} = 6V$ ,  $T_a = 25^\circ C$ )

[Unit: V]

Terminal no.	1	2	3	4	5	6	7	8	9	10
DC voltage (V)	NC	6.0	NC	0	2.40	0.62	0.64	0	0	2.61



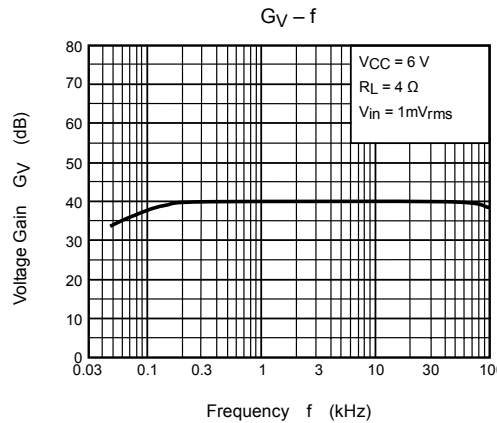
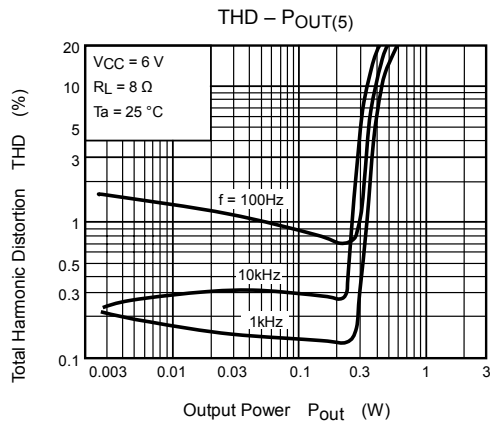
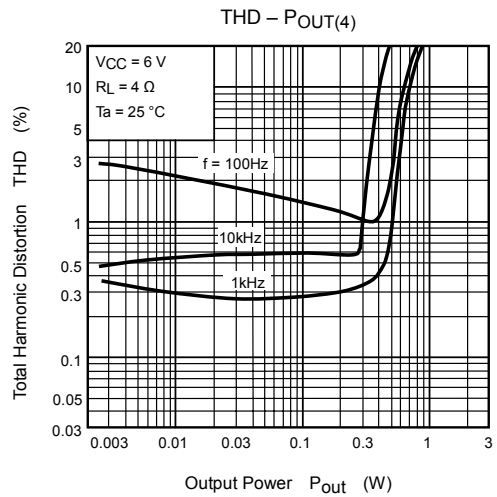
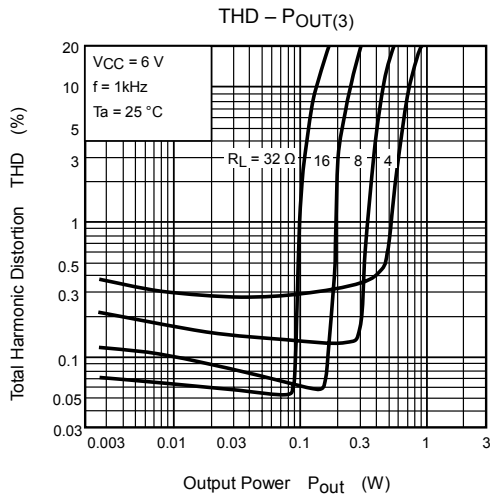
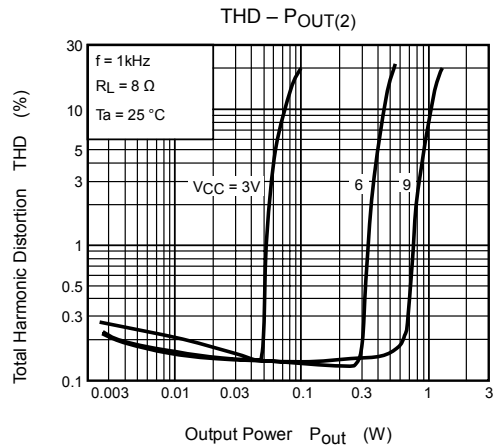
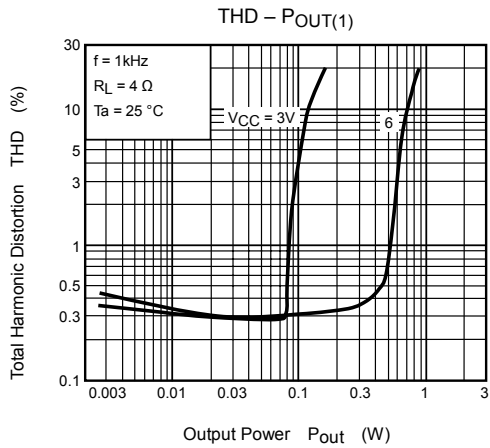

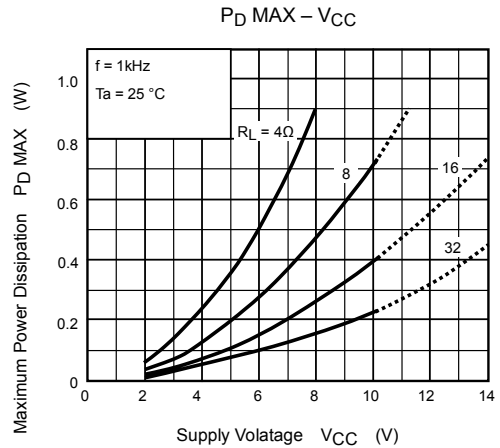
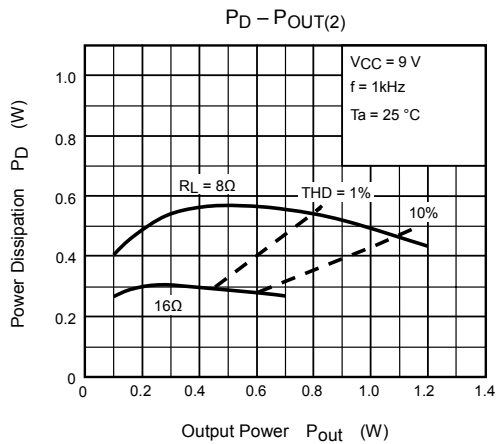
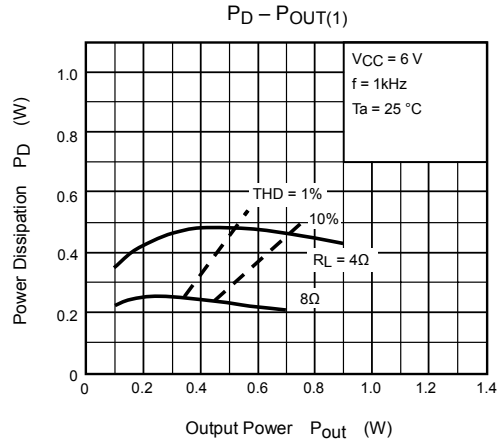
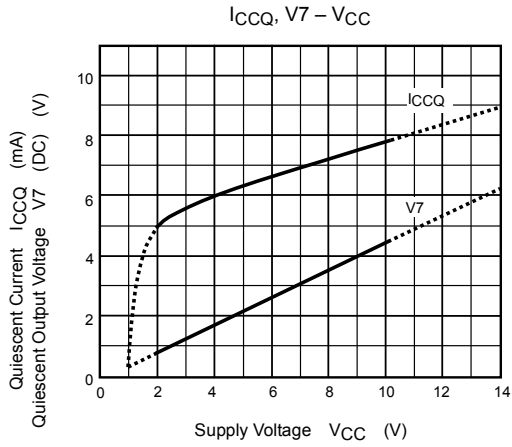
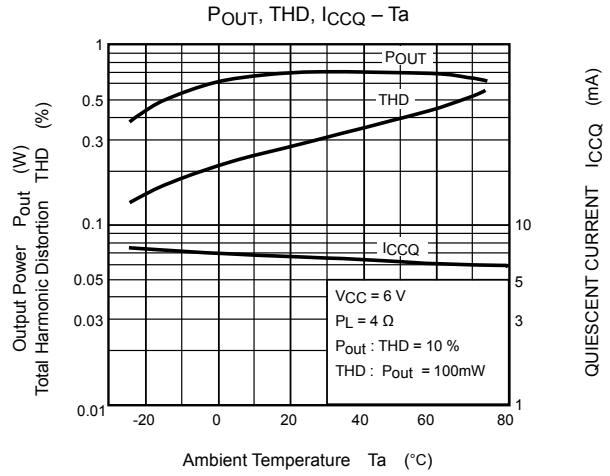
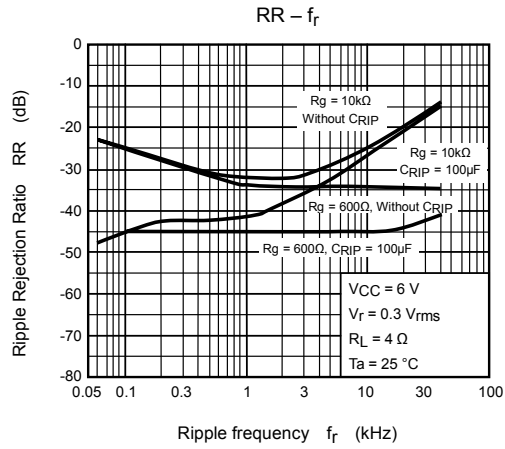

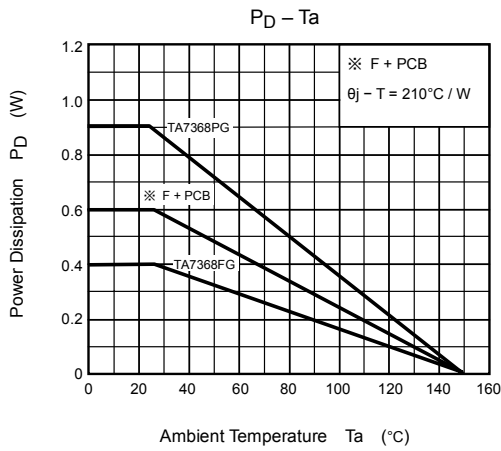

※ F+PCB

By being mounted on certain PCB's, flat packages increase the heat dissipating efficiency.

Data shown on the left is resulted from the measurement on the PCB recommended by TOSHIBA.

( $\theta_j - T$  : Thermal resistance)

**Printed Circuit Board**

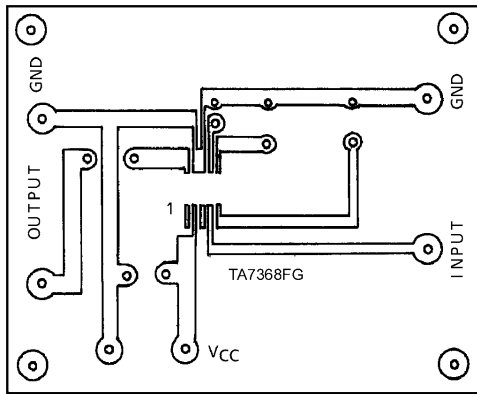

60 x 47.5 (mm)

Material: Phenol resin  
 Thickness of copper leaf: 35 $\mu$ m  
 Plate thickness: 1.6mm



**Package Dimensions**

SIP9-P-2.54A

Unit : mm

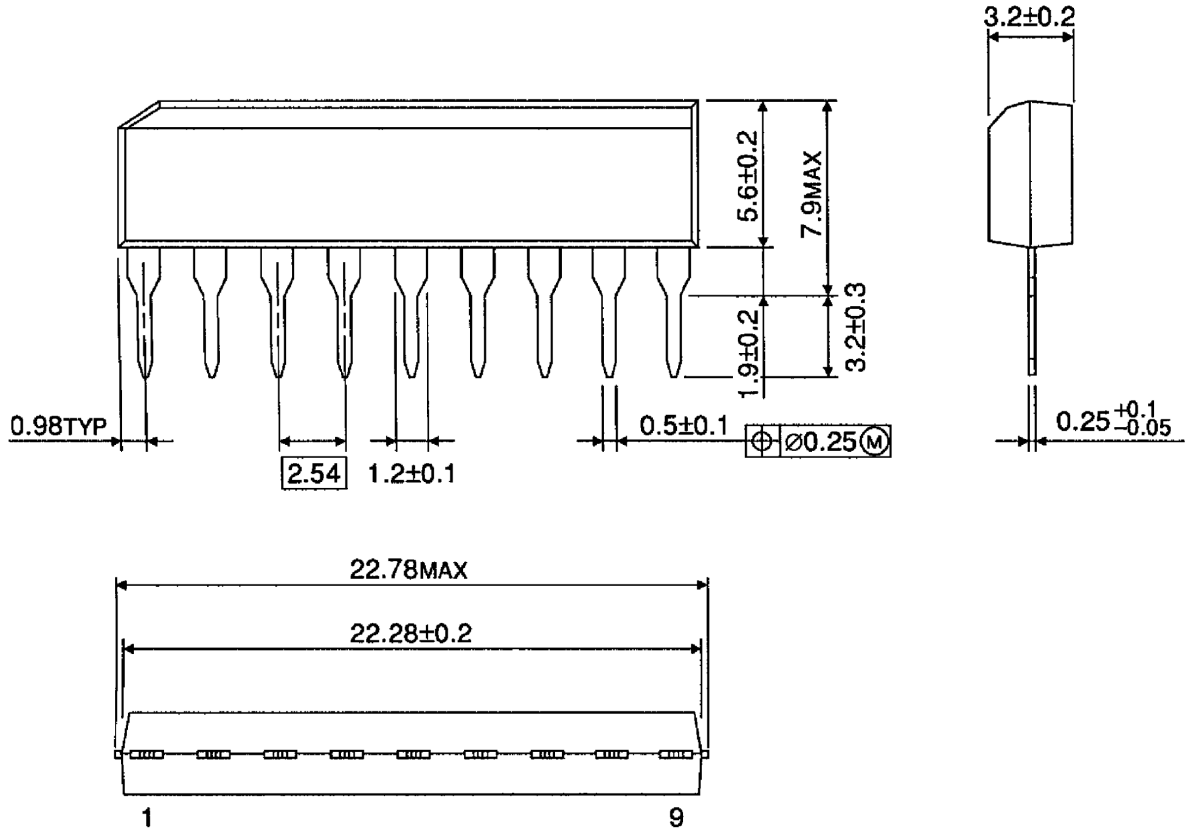

Weight: 0.92g (typ.)

**Package Dimensions**

SSOP10-P-225-1.00

Unit : mm

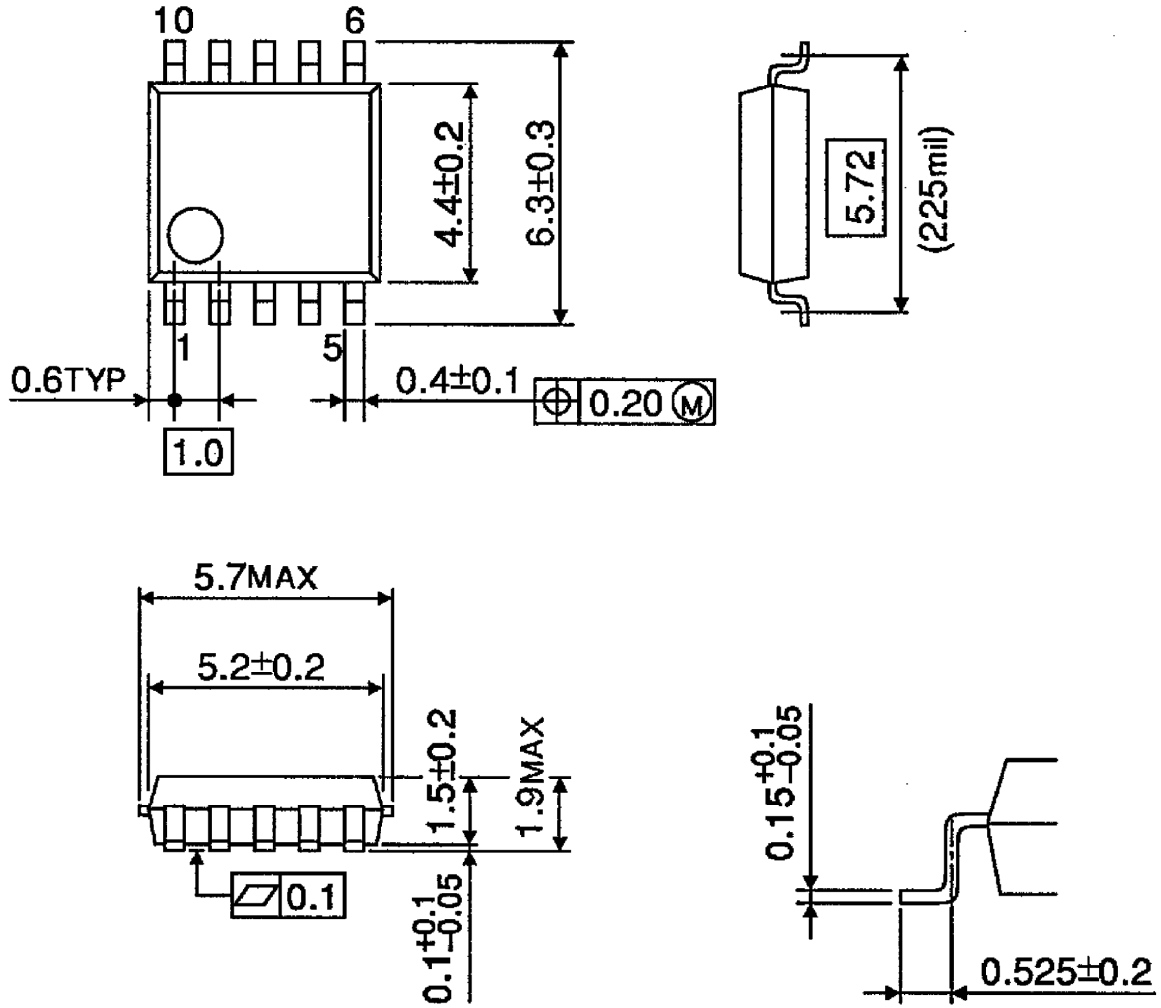

Weight: 0.09g (typ.)

- Use an appropriate power supply fuse to ensure that a large current does not continuously flow in case of over current and/or IC failure. The IC will fully break down when used under conditions that exceed its absolute maximum ratings, when the wiring is routed improperly or when an abnormal pulse noise occurs from the wiring or load, causing a large current to continuously flow and the breakdown can lead smoke or ignition. To minimize the effects of the flow of a large current in case of breakdown, appropriate settings, such as fuse capacity, fusing time and insertion circuit location, are required.
- If your design includes an inductive load such as a motor coil, incorporate a protection circuit into the design to prevent device malfunction or breakdown caused by the current resulting from the inrush current at power ON or the negative current resulting from the back electromotive force at power OFF. For details on how to connect a protection circuit such as a current limiting resistor or back electromotive force adsorption diode, refer to individual IC datasheets or the IC databook. IC breakdown may cause injury, smoke or ignition.
- Use a stable power supply with ICs with built-in protection functions. If the power supply is unstable, the protection function may not operate, causing IC breakdown. IC breakdown may cause injury, smoke or ignition.
- Carefully select external components (such as inputs and negative feedback capacitors) and load components (such as speakers), for example, power amp and regulator. If there is a large amount of leakage current such as input or negative feedback condenser, the IC output DC voltage will increase. If this output voltage is connected to a speaker with low input withstand voltage, overcurrent or IC failure can cause smoke or ignition. (The over current can cause smoke or ignition from the IC itself.) In particular, please pay attention when using a Bridge Tied Load (BTL) connection type IC that inputs output DC voltage to a speaker directly.
- Over current Protection Circuit  
Over current protection circuits (referred to as current limiter circuits) do not necessarily protect ICs under all circumstances. If the Over current protection circuits operate against the over current, clear the over current status immediately. Depending on the method of use and usage conditions, such as exceeding absolute maximum ratings can cause the over current protection circuit to not operate properly or IC breakdown before operation. In addition, depending on the method of use and usage conditions, if over current continues to flow for a long time after operation, the IC may generate heat resulting in breakdown.
- Thermal Shutdown Circuit  
Thermal shutdown circuits do not necessarily protect ICs under all circumstances. If the Thermal shutdown circuits operate against the over temperature, clear the heat generation status immediately. Depending on the method of use and usage conditions, such as exceeding absolute maximum ratings can cause the thermal shutdown circuit to not operate properly or IC breakdown before operation.
- Heat Radiation Design  
When using an IC with large current flow such as power amp, regulator or driver, please design the device so that heat is appropriately radiated, not to exceed the specified junction temperature ( $T_j$ ) at any time and condition. These ICs generate heat even during normal use. An inadequate IC heat radiation design can lead to decrease in IC life, deterioration of IC characteristics or IC breakdown. In addition, please design the device taking into considerate the effect of IC heat radiation with peripheral components.
- Installation to Heat Sink  
Please install the power IC to the heat sink not to apply excessive mechanical stress to the IC. Excessive mechanical stress can lead to package cracks, resulting in a reduction in reliability or breakdown of internal IC chip. In addition, depending on the IC, the use of silicon rubber may be prohibited. Check whether the use of silicon rubber is prohibited for the IC you intend to use, or not. For details of power IC heat radiation design and heat sink installation, refer to individual technical datasheets or IC databooks.

**RESTRICTIONS ON PRODUCT USE**

060116EBA

- The information contained herein is subject to change without notice. 021023\_D
- TOSHIBA is continually working to improve the quality and reliability of its products. Nevertheless, semiconductor devices in general can malfunction or fail due to their inherent electrical sensitivity and vulnerability to physical stress. It is the responsibility of the buyer, when utilizing TOSHIBA products, to comply with the standards of safety in making a safe design for the entire system, and to avoid situations in which a malfunction or failure of such TOSHIBA products could cause loss of human life, bodily injury or damage to property.  
In developing your designs, please ensure that TOSHIBA products are used within specified operating ranges as set forth in the most recent TOSHIBA products specifications. Also, please keep in mind the precautions and conditions set forth in the "Handling Guide for Semiconductor Devices," or "TOSHIBA Semiconductor Reliability Handbook" etc. 021023\_A
- The TOSHIBA products listed in this document are intended for usage in general electronics applications (computer, personal equipment, office equipment, measuring equipment, industrial robotics, domestic appliances, etc.). These TOSHIBA products are neither intended nor warranted for usage in equipment that requires extraordinarily high quality and/or reliability or a malfunction or failure of which may cause loss of human life or bodily injury ("Unintended Usage"). Unintended Usage include atomic energy control instruments, airplane or spaceship instruments, transportation instruments, traffic signal instruments, combustion control instruments, medical instruments, all types of safety devices, etc. Unintended Usage of TOSHIBA products listed in this document shall be made at the customer's own risk. 021023\_B
- The products described in this document shall not be used or embedded to any downstream products of which manufacture, use and/or sale are prohibited under any applicable laws and regulations. 060106\_Q
- The information contained herein is presented only as a guide for the applications of our products. No responsibility is assumed by TOSHIBA for any infringements of patents or other rights of the third parties which may result from its use. No license is granted by implication or otherwise under any patent or patent rights of TOSHIBA or others. 021023\_C
- The products described in this document are subject to the foreign exchange and foreign trade laws. 021023\_E

About solderability, following conditions were confirmed

- Solderability
  - (1) Use of Sn-37Pb solder Bath
    - solder bath temperature = 230°C
    - dipping time = 5 seconds
    - the number of times = once
    - use of R-type flux
  - (2) Use of Sn-3.0Ag-0.5Cu solder Bath
    - solder bath temperature = 245°C
    - dipping time = 5 seconds
    - the number of times = once
    - use of R-type flux