

Preliminary TOSHIBA Bipolar Liner Integrated Circuit Silicon Monolithic

TA2125AF

Power Driver IC for CD Player

TA2125AF is power driver IC developed for CD players. This IC have built-in 4 channel BTL power amplifiers and 1 channel H-Bridge driver. Which drives focus-coil and tracking coil for 3-beam pick-up head, disc motor, feed motor and loading motor.

Features

- 4 channel BTL linear drivers
High output power: $V_{out} = 5.1 V_{p-p}$ ($V_{CC} = 8 V, R_L = 8 \Omega$)
Stand-by switch for BTL drivers
- 1 channel H-Bridge: $V_{CE} (H) + V_{CE} (L) = 1.3 V$ ($V_R = V_M = 8 V, I_O = 200 mA$)
Logic control (forward, revers, brake, stand-by)
- Punch through current restriction diode for H-bridge
- 5 V regulator reference amp (with external output Tr.)
- Thermal shut down protection
- Operating supply voltage range: $V_{CC} = 5.0$ to $9.0 V$

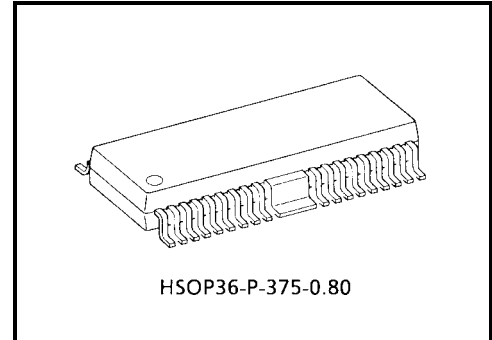

Weight: 0.74 g (typ.)

Block Diagram

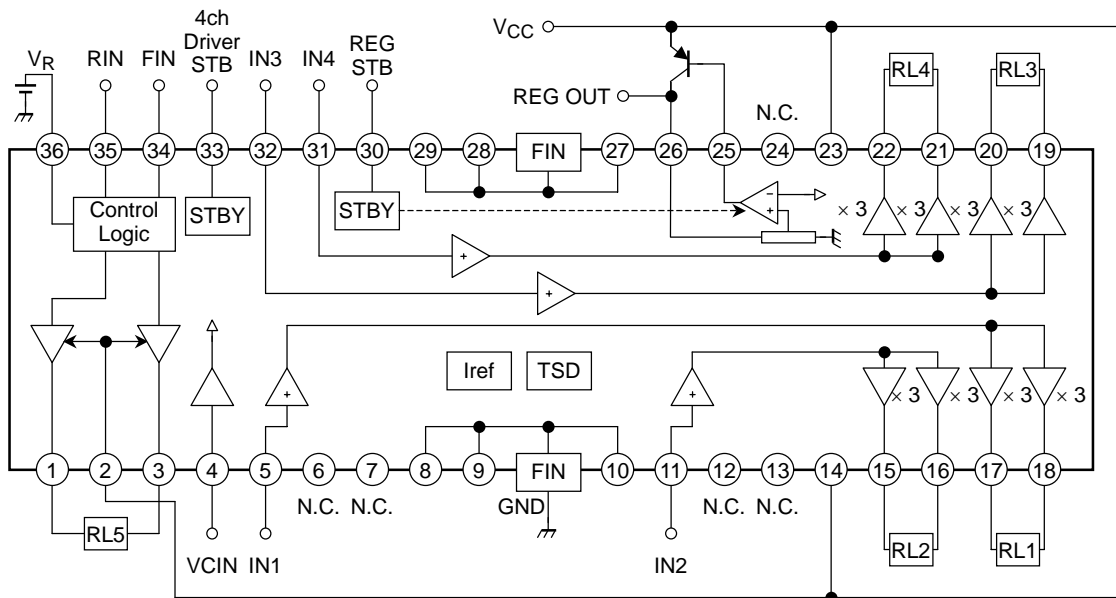

Terminal Explanation

No.	Symbol	Function	
1	OUT5A	Output terminal	H-bridge
2	V _M	Supply voltage terminal for Logic	H-bridge
3	OUT5B	Output terminal	H-bridge
4	V _{CIN}	Input reference voltage	4ch BTL
5	IN1	Input for ch1	4ch BTL
6	N.C.	Open	—
7	N.C.	Open	—
8	N.C.	8, 9, 10, 27, 28, 29 are connected to PW GND (FIN)	—
9	N.C.	8, 9, 10, 27, 28, 29 are connected to PW GND (FIN)	—
10	N.C.	8, 9, 10, 27, 28, 29 are connected to PW GND (FIN)	—
11	IN2	Input for ch2	4ch BTL
12	N.C.	Open	—
13	N.C.	Open	—
14	V _{CC1}	Supply voltage terminal for ch1/ch2	4ch BTL
15	OUT2M	Inverted output for ch2	4ch BTL
16	OUT2P	Non-inverted output for ch2	4ch BTL
17	OUT1M	Inverted output for ch1	4ch BTL
18	OUT1P	Non-inverted output for ch1	4ch BTL
19	OUT3P	Non-inverted output for ch3	4ch BTL
20	OUT3M	Inverted output for ch3	4ch BTL
21	OUT4P	Non-inverted output for ch4	4ch BTL
22	OUT4M	Inverted output for ch4	4ch BTL
23	V _{CC2}	Supply voltage terminal for ch3/ch4	4ch BTL
24	N.C.	Open	—
25	REG	Connection with BASE of PNP Tr	Regulator
26	REG OUT	Output for regulator (5 V)	Regulator
27	N.C.	8, 9, 10, 27, 28, 29 are connected to PW GND (FIN)	—
28	N.C.	8, 9, 10, 27, 28, 29 are connected to PW GND (FIN)	—
29	N.C.	8, 9, 10, 27, 28, 29 are connected to PW GND (FIN)	—
30	REG STBY	Standby control for regulator	Regulator
31	IN4	Input for ch4	4ch BTL
32	IN3	Input for ch3	4ch BTL
33	STBY	Standby control for 4ch BTL	4ch BTL
34	FIN	Logic control input	H-bridge
35	RIN	Logic control input	H-bridge
36	VR	Supply voltage terminal for motor driver	H-bridge

Precaution Use

(4ch BTL)

- Input stage
Minimum input DC voltage range for buffer is 0.2 V
- Driver stage
Each channel driver consists of BTL configuration linear amplifier.
Voltage gain is fixed: $G_v = 15.2\text{dB}$
- VCIN terminal
VCIN is reference voltage terminal for input signal
- GND
Pin 8~10 and Pin 27~29 are connected to FIN through inner lead frame.
Each FIN are not connected each other also.
The heat of power dissipation is transferred to PCB, through PW-GND Pin. PW GND is connected to substrate of Pellet to connected copper foil area as large as possible.
- VCC1/VCC2
Pin 14 and pin 23 are not connected through AL layer on chip.

(H-Bridge)

- VR/VM terminal
VR terminal is control for H-bridge dynamic range. $I_{36} = 30\text{ mA}$ (Brake Mode)
VM terminal is VCC terminal for H-Bridge.
- STBY/REG STBY
STBY is standby control terminal for 4ch BTL.
REG STBY is standby control terminal for regulator.

Maximum Ratings (Ta = 25°C)

Characteristics	Symbol	Rating	Unit
Supply voltage	V _{CC}	12	V
Power dissipation	P _D	1.7	W
Operating temperature	T _{opr}	-35~85	°C
Storage temperature	T _{stg}	-55~150	°C

Electrical Characteristics

(Unless otherwise specified, $V_{CC} = 8\text{ V}$, $R_L = 8\ \Omega$, $V_{BIAS} = 2.1\text{ V}$, $f = 1\text{ kHz}$, $T_a = 25^\circ\text{C}$)

Characteristics	Symbol	Test Circuit	Test Condition	Min	Typ.	Max	Unit
Operating supply voltage	$V_{CC1, 2}$	—	—	5	8	9	V
Quiescent current	I_{ccq}	—	$V_{IN} = V_{BIAS}$, $R_L = \text{OPEN}$ (With out H-SW)	27	37	60	mA

4ch BTL Driver

Characteristics	Symbol	Test Circuit	Test Condition	Min	Typ.	Max	Unit
Output offset voltage	V_{OS}	—	$R_g = 0$	-50	10	50	mV
Maximum output voltage	V_{OM}	—	$V_{IN} = 4\text{ V/GND}$	4.5	5.1	—	V
Voltage gain	Gv	—	$V_{IN} = V_{BIAS} \pm 200\text{ mV}$	14.0	15.2	16.4	dB
Stand-by 1 control voltage	$V_{STB (on)}$	—		—	—	0.5	V
	$V_{STB (off)}$	—		3.0	—	—	V
Stand-by current	I_{STB1}	—	$V_{IN} = V_{BIAS}$, $R_L = \text{OPEN}$ H-Bridge: Stand-by 5 V REG: Stand-by	—	—	1	μA

Regulator Reference Amp

Characteristics	Symbol	Test Circuit	Test Condition	Min	Typ.	Max	Unit
Output voltage	V_{reg}	—	$I_o = 200\text{ mA}$ Tr. 2SA1203Y	4.6	5	5.2	V
Regulator control voltage	$V_{reg (on)}$	—		2.5	—	V_{CC}	V
	$V_{reg (off)}$	—		GND	—	1.5	V

H-Bridge

Characteristics	Symbol	Test Circuit	Test Condition	Min	Typ.	Max	Unit
Output saturation voltage	V_{CE}	—	$I_o = 200\text{ mA}$	—	1.3	1.4	V
Stand-by current	I_{STB2}	—	4ch BTL: Stand-by 5 V REG: Stand-by	—	—	1	μA
Control voltage	$V_{HB (on)}$	—		2.5	—	V_{CC}	V
	$V_{HB (off)}$	—		GND	—	0.7	V

H-Bridge Control Logic/ V_R Current (36pin)

Operation Mode	Fin	Rin	Out5A	Out5B	V_R Current	Unit
Forward	H	L	L	H	19.5	mA
Revers	L	H	H	L	19.5	mA
Brake	H	H	L	L	30	mA
Stand-by	L	L	Open	Open	1	μA

Test Circuit

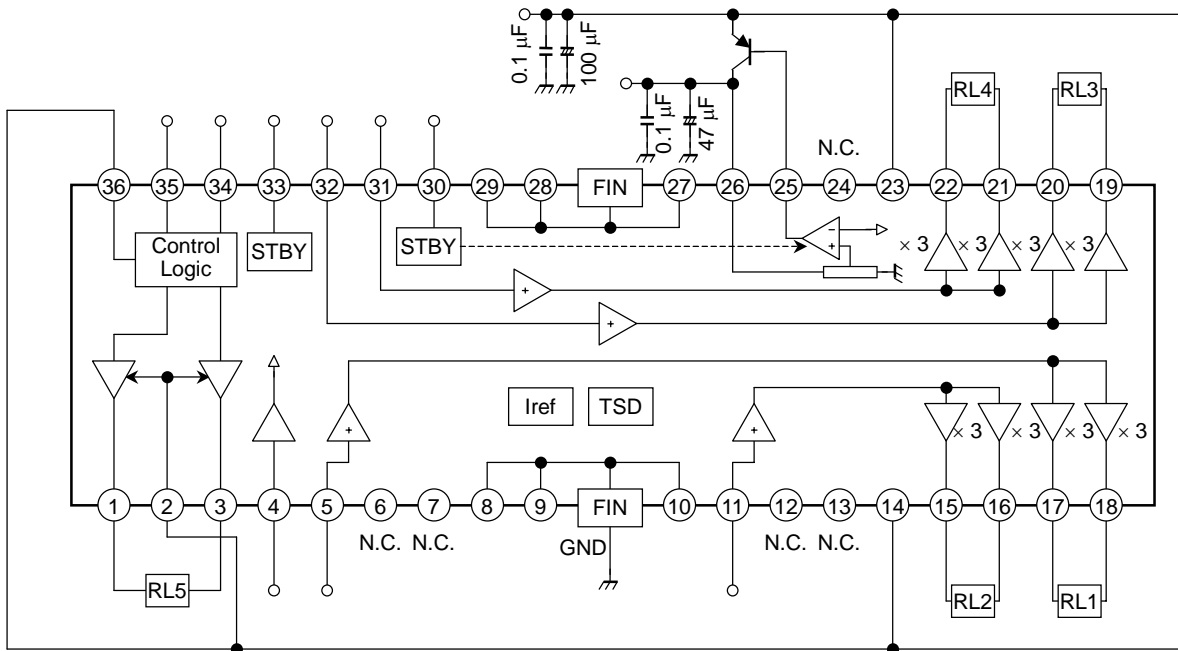

Package Dimensions

HSOP36-P-375-0.80

Unit : mm

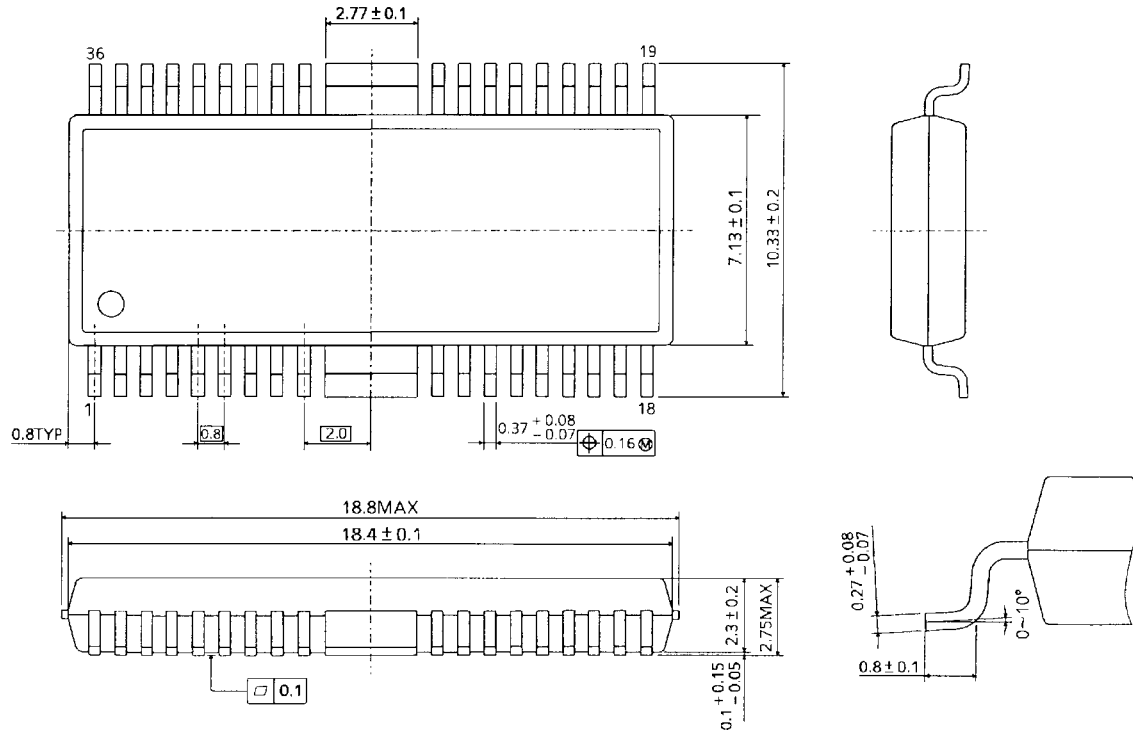

Weight: 0.74 g (typ.)

RESTRICTIONS ON PRODUCT USE

030619EBF

- The information contained herein is subject to change without notice.
- The information contained herein is presented only as a guide for the applications of our products. No responsibility is assumed by TOSHIBA for any infringements of patents or other rights of the third parties which may result from its use. No license is granted by implication or otherwise under any patent or patent rights of TOSHIBA or others.
- TOSHIBA is continually working to improve the quality and reliability of its products. Nevertheless, semiconductor devices in general can malfunction or fail due to their inherent electrical sensitivity and vulnerability to physical stress. It is the responsibility of the buyer, when utilizing TOSHIBA products, to comply with the standards of safety in making a safe design for the entire system, and to avoid situations in which a malfunction or failure of such TOSHIBA products could cause loss of human life, bodily injury or damage to property.
In developing your designs, please ensure that TOSHIBA products are used within specified operating ranges as set forth in the most recent TOSHIBA products specifications. Also, please keep in mind the precautions and conditions set forth in the "Handling Guide for Semiconductor Devices," or "TOSHIBA Semiconductor Reliability Handbook" etc..
- The TOSHIBA products listed in this document are intended for usage in general electronics applications (computer, personal equipment, office equipment, measuring equipment, industrial robotics, domestic appliances, etc.). These TOSHIBA products are neither intended nor warranted for usage in equipment that requires extraordinarily high quality and/or reliability or a malfunction or failure of which may cause loss of human life or bodily injury ("Unintended Usage"). Unintended Usage include atomic energy control instruments, airplane or spaceship instruments, transportation instruments, traffic signal instruments, combustion control instruments, medical instruments, all types of safety devices, etc.. Unintended Usage of TOSHIBA products listed in this document shall be made at the customer's own risk.
- The products described in this document are subject to the foreign exchange and foreign trade laws.
- TOSHIBA products should not be embedded to the downstream products which are prohibited to be produced and sold, under any law and regulations.
- This product generates heat during normal operation. However, substandard performance or malfunction may cause the product and its peripherals to reach abnormally high temperatures.
The product is often the final stage (the external output stage) of a circuit. Substandard performance or malfunction of the destination device to which the circuit supplies output may cause damage to the circuit or to the product.