

TOSHIBA Bipolar Linear Integrated Circuit Silicon Monolithic

TA2003PG, TA2003FG

AM / FM Radio IC

The TA2003PG, TA2003FG are AM / FM radio IC (FM F / E+AM / FM IF) which are designed for AM / FM radios.

Combining with the TA7368P (Mono PW IC), a suitable AM / FM radio system is able to be constituted.

Features

- FM IFT, AM IFT and FM detector coil are not needed.
- Pin compatible of TA8164P.
- Operating supply voltage range
: $V_{CC(opr)} = 1.8 \sim 7V$ ($T_a = 25^\circ C$)

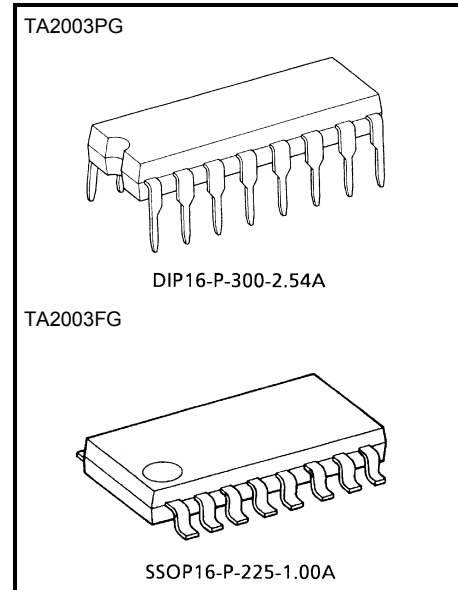

Weight

DIP16-P-300-2.54A: 1.00g (typ.)

SSOP16-P-225-1.00A: 0.14g (typ.)

Block Diagram

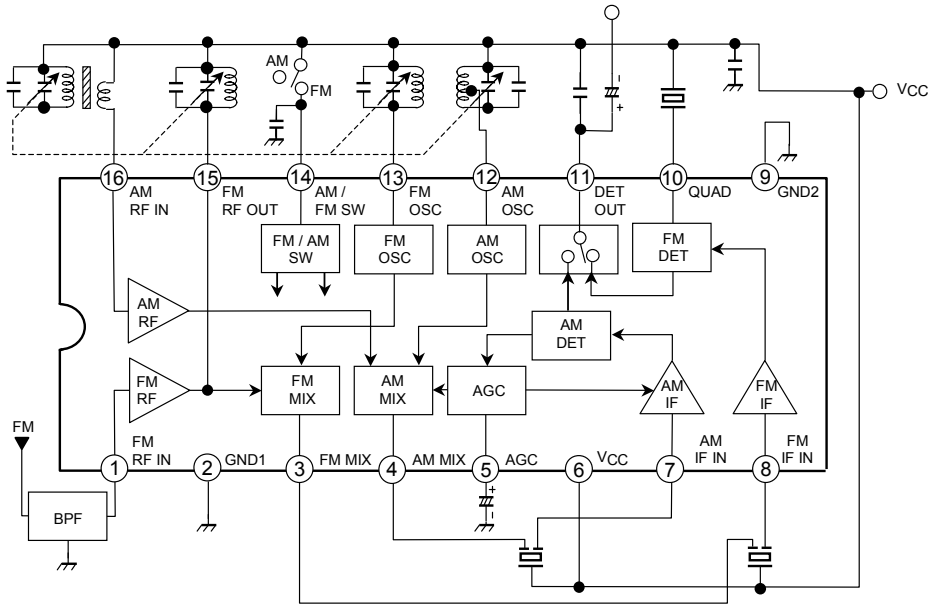

Explanation Of Terminals

Terminal voltage: Typical DC voltage at Ta = 25°C, V_{CC} = 3V and no signal with test circuit 1

Pin No.	Symbol	Contents	Internal Circuit	Terminal Voltage(V)	
				AM	FM
1	FM RF in	Input of FM RF amplifier		0	0.7
2	GND1	GND for RF, OSC and mix stage	—	0	0
3	FM mix	Output of FM mix		0.4	1.7
4	AM mix	Output of AM mix		0.6	0
5	AGC	By-pass of AM AGC		0	0
6	V _{CC}	—	—	3.0	3.0

Pin No.	Symbol	Contents	Internal Circuit	Terminal Voltage(V)	
				AM	FM
7	AM IF in	Input of AM IF amplifier		3.0	3.0
8	FM IF in	Input of FM IF amplifier		3.0	3.0
9	GND2	GND for IF stage	—	0	0
10	QUAD	FM QUAD detector Ceramic discriminator is connected. Recommendation CDA10.7MG31 (MURATA MGF. CO., LTD)		2.5	2.2
11	DET out	Output of FM / AM detector	<p>Ⓐ Low→FM, High→AM Ⓑ Low→AM, High→FM</p>	1.4	1.1
12	AM OSC	AM local oscillator terminal oscillator coil is connected.		3.0	3.0

Pin No.	Symbol	Contents	Internal Circuit	Terminal Voltage(V)	
				AM	FM
13	FM OSC	FM local oscillator terminal Oscillator coil is connected.		0.9	3.0
14	AM / FM SW	AM / FM switch connected to Pin(14) V_{CC} →FM mode Pin(14) open→AM mode		0.9	3.0
15	FM RF out	FM RF coil is connected.	cf. pin(1)	3.0	3.0
16	AM RF in	Input of AM RF amplifier		3.0	3.0

Absolute Maximum Ratings (Ta = 25°C)

Characteristic	Symbol	Rating	Unit
Supply voltage	V _{CC}	8	V
Power dissipation	DIP-16	750	mW
	SSOP-16	350	
Operating temperature	T _{opr}	-25~75	°C
Storage temperature	T _{stg}	-55~150	°C

(Note) Derated above Ta = 25°C in the proportion of 6mW / °C for TA2003PG and of 2.8mW / °C for TA2003FG.

Electrical Characteristics

Unless otherwise specified, Ta = 25°C, V_{CC} = 3V, F / E: f = 98MHz, f_m = 1kHz

FM IF: f = 10.7MHz, Δf = ±22.5kHz, f_m = 1kHz

AM: f = 1MHz, MOD = 30%, f_m = 1kHz

Characteristic	Symbol	Test Circuit	Test Condition	Min.	Typ.	Max.	Unit
Supply current	I _{CC} (FM)	1	FM mode, V _{in} = 0	—	10.5	16.5	mA
	I _{CC} (AM)	1	AM mode, V _{in} = 0	—	5.0	8.0	
F / E	Input limiting voltage	V _{in} (lim)	-3dB limiting point	—	12	—	dBμV EMF
	Quiescent sensitivity	Q _S	S / N = 30dB	—	12	—	dBμV EMF
	Local OSC voltage	V _{OSC}	f _{OSC} = 108MHz	160	240	320	mV _{rms}
	Local OSC stop voltage	V _{stop} (FM)	V _{in} = 0	—	1.2	—	V
FM IF	Input limiting voltage	V _{in} (lim) IF	-3dB limiting point	42	47	52	dBμV EMF
	Recovered output voltage	V _{OD}	V _{in} = 80dBμV EMF	50	70	90	mV _{rms}
	Signal to noise ratio	S / N	V _{in} = 80dBμV EMF	—	62	—	dB
	Total harmonic distortion	THD	V _{in} = 80dBμV EMF	—	0.4	—	%
	AM rejection ratio	AMR	V _{in} = 80dBμV EMF	—	33	—	dB
AM	Voltage gain	G _V	V _{in} = 27dBμV EMF	15	32	50	mV _{rms}
	Recovered output voltage	V _{OD}	V _{in} = 60dBμV EMF	35	60	85	mV _{rms}
	Signal to noise ratio	S / N	V _{in} = 60dBμV EMF	—	43	—	dB
	Total harmonic distortion	THD	V _{in} = 60dBμV EMF	—	1.0	—	%
	Local OSC stop voltage	V _{stop} (AM)	V _{in} = 0	—	1.6	—	V

Test Circuit 1

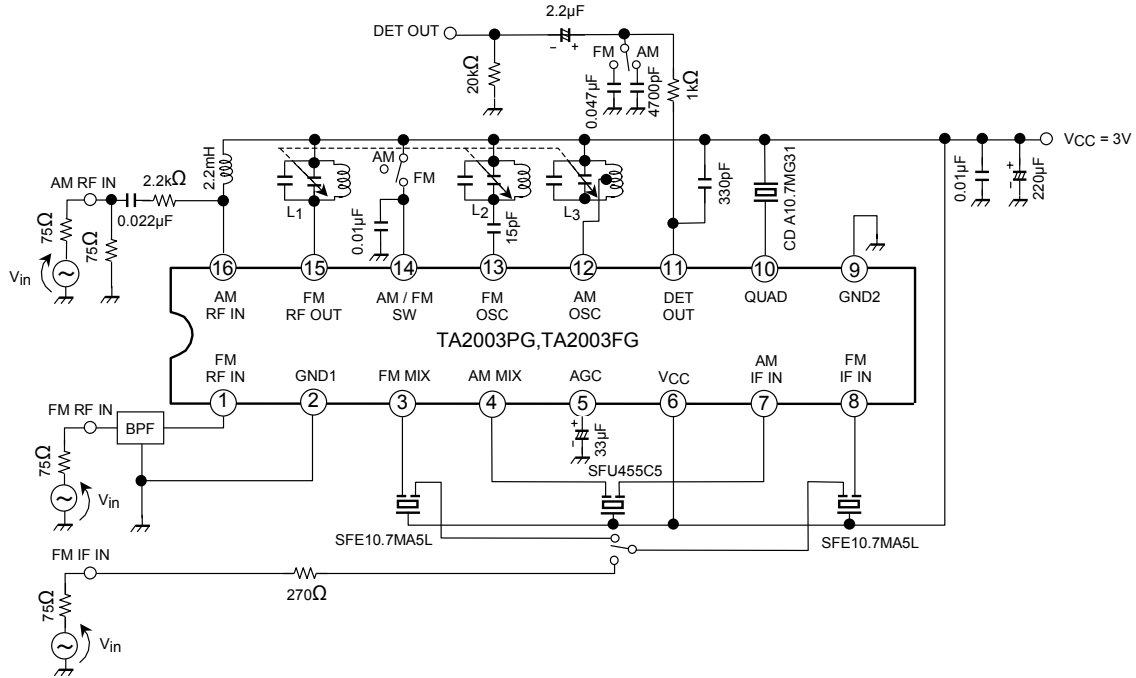

Test Circuit 2

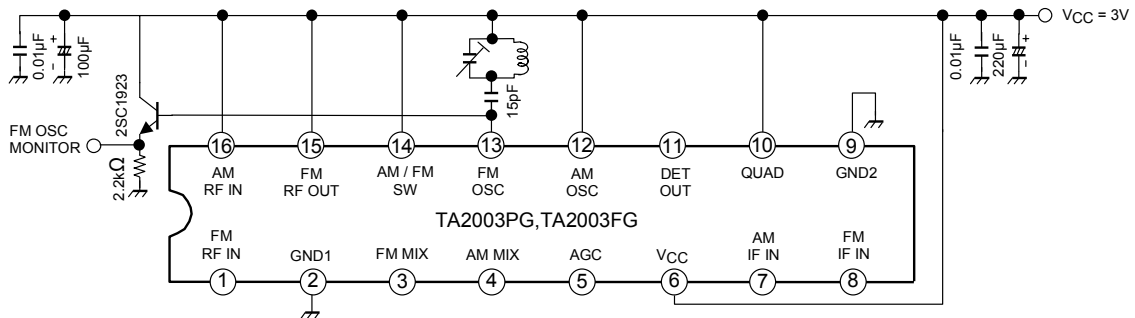

Coil Data(Test circuit)

Coil No.	Test Freq. (Hz)	L (μ H)	C _O (pF)	Q _O	Turns					Wire (mm ϕ)	Reference
					1-2	2-3	1-3	1-4	4-6		
L ₁ FM RF	100M	—	—	100	—	—	—	2 $\frac{1}{4}$	—	0.5UEW	(S)0258-000-021
L ₂ FM OSC	100M	—	—	100	—	—	1 $\frac{3}{4}$	—	—	0.5UEW	(S)0258-000-020
L ₃ AM OSC	796k	268	—	125	14	86	—	—	—	0.06UEW	(S)2157-2239-213A

(S): SUMIDA ELECTRIC CO., LTD.

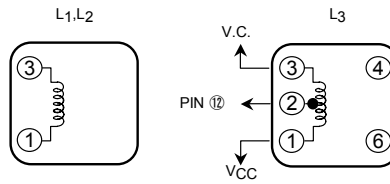

Package Dimensions

DIP16-P-300-2.54A

Unit : mm

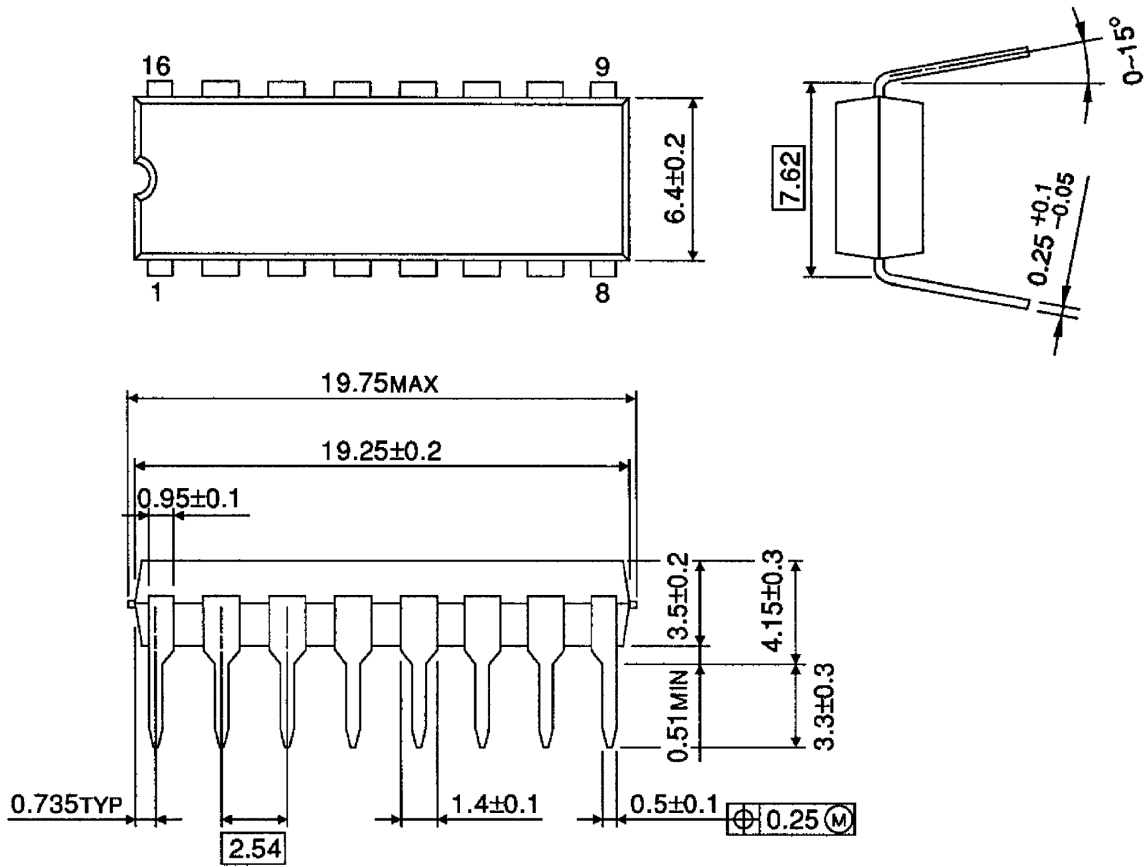

Weight: 1.00g (typ.)

Package Dimensions

SSOP16-P-225-1.00A

Unit : mm

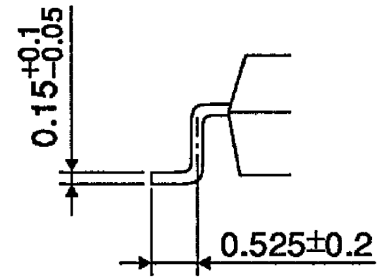
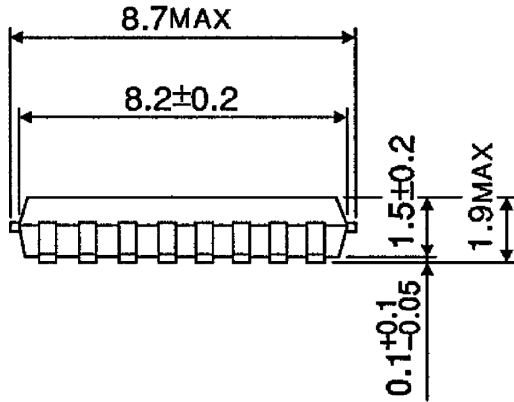
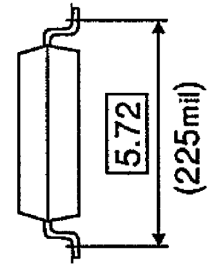
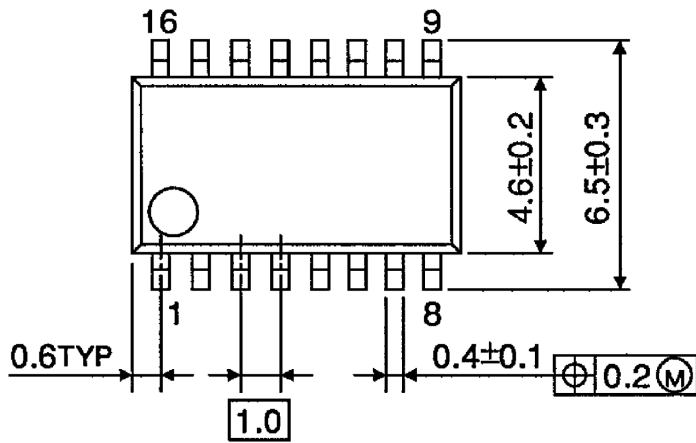

Weight: 0.14g (typ.)

RESTRICTIONS ON PRODUCT USE

060116EBA

- The information contained herein is subject to change without notice. 021023_D
- TOSHIBA is continually working to improve the quality and reliability of its products. Nevertheless, semiconductor devices in general can malfunction or fail due to their inherent electrical sensitivity and vulnerability to physical stress. It is the responsibility of the buyer, when utilizing TOSHIBA products, to comply with the standards of safety in making a safe design for the entire system, and to avoid situations in which a malfunction or failure of such TOSHIBA products could cause loss of human life, bodily injury or damage to property.
In developing your designs, please ensure that TOSHIBA products are used within specified operating ranges as set forth in the most recent TOSHIBA products specifications. Also, please keep in mind the precautions and conditions set forth in the "Handling Guide for Semiconductor Devices," or "TOSHIBA Semiconductor Reliability Handbook" etc. 021023_A
- The TOSHIBA products listed in this document are intended for usage in general electronics applications (computer, personal equipment, office equipment, measuring equipment, industrial robotics, domestic appliances, etc.). These TOSHIBA products are neither intended nor warranted for usage in equipment that requires extraordinarily high quality and/or reliability or a malfunction or failure of which may cause loss of human life or bodily injury ("Unintended Usage"). Unintended Usage include atomic energy control instruments, airplane or spaceship instruments, transportation instruments, traffic signal instruments, combustion control instruments, medical instruments, all types of safety devices, etc. Unintended Usage of TOSHIBA products listed in this document shall be made at the customer's own risk. 021023_B
- The products described in this document shall not be used or embedded to any downstream products of which manufacture, use and/or sale are prohibited under any applicable laws and regulations. 060106_Q
- The information contained herein is presented only as a guide for the applications of our products. No responsibility is assumed by TOSHIBA for any infringements of patents or other rights of the third parties which may result from its use. No license is granted by implication or otherwise under any patent or patent rights of TOSHIBA or others. 021023_C
- The products described in this document are subject to the foreign exchange and foreign trade laws. 021023_E

About solderability, following conditions were confirmed

- Solderability
 - (1) Use of Sn-37Pb solder Bath
 - solder bath temperature = 230°C
 - dipping time = 5 seconds
 - the number of times = once
 - use of R-type flux
 - (2) Use of Sn-3.0Ag-0.5Cu solder Bath
 - solder bath temperature = 245°C
 - dipping time = 5 seconds
 - the number of times = once
 - use of R-type flux