

TOSHIBA Bipolar Linear Integrated Circuit Silicon Monolithic

TA1372FNG

VHF Band RF Modulator IC for VCRs and Set top boxes

The TA1372FNG is a VHF band RF modulator IC that features PLL-based RF carrier and sound intercarrier oscillation.

There is no external parts of RF Oscillator and Sound Oscillator. Therefore, PCB design and adjustment with much time are not required.

The TA1372FNG is compatible with CH 3 & CH 4 (U.S.A. channel) of NTSC television system.

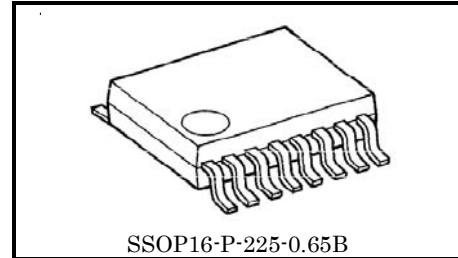

Weight: 0.07 g (typ.)

Features

- RF Oscillator is all built in IC and external tank circuit is not required.
(U.S.A. channels CH 3 & CH 4)
- Sound Oscillator is all built in IC and external tank circuit is not required.
Formats supported: System M
- The Picture to Sound ratio is set up by external resistance.
- Muted RF output on power-on and as required.
- Reference signal can use 4MHz and 3.579545MHz.
These modes are selected by pin 1.
- In Carrier off mode, Supply current is saved by stopping Sound VCO.
- There is White Clip Through Mode in test mode.
- Package is improved to Lead-Free

Block Diagram

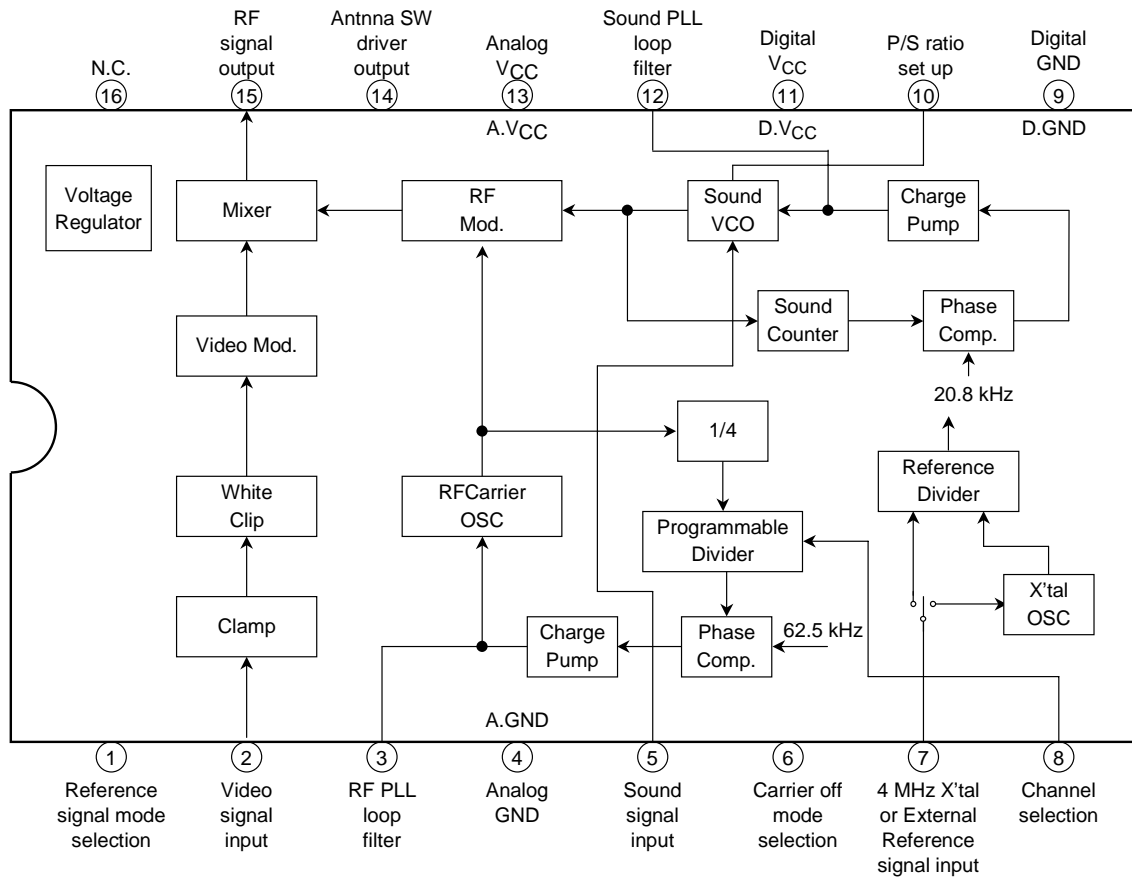

Some of the functional blocks, circuits, or constants in the block diagram may be omitted or simplified for explanatory purpose.

Pin Description ($V_{CC} = 5.0\text{ V}$, $T_a = 25^\circ\text{C}$)

The equivalent circuit diagrams may be simplified or some parts of them may be omitted for explanatory purpose.

Pin No.	Name	DC Voltage (typ.)	AC Voltage (typ.)	Interface equivalent circuit	Note
1	Reference signal Mode selection	H: 5 V M: 2.5V L: 0 V	—		Reference signal Mode can be selected this pin. High or Open: 4MHz external input mode Middle: 3.579545MHz external input mode Low: Internal Oscillation Mode with 4MHz X'tal
2	Video signal Input	2.4 V (sync tip)	500 mV _{p-p} (80% modulation)		Sync tip clamp input. It is used by AC coupling. Video modulation depth is set by level of input signal on this pin. White clip level for IC is set internally for DC, but it will change by the high frequency-factor.
3	RF PLL loop filter	—	—		RF oscillation frequency is compared with RF setting frequency (pin 8), and the error is outputted by Charge pump. LPF for high frequency rejection is connected to this terminal. And the voltage for RF VCO control is generated. The reference frequency is 62.5 kHz.
4	Analog GND	(0 V)	—	—	Analog GND
5	Sound signal input	H: 5 V M: 2.5V L: 0 V (normal mode)	167 mV _{p-p} (100% FM modulation)		Sound modulation depth is set by level of sound signal input on this pin. Sound pre-emphasis is applied before this pin. This pin is also used for switching test mode. Normally this pin is used at 0 V DC (used by AC coupling). H: Test mode M: Test mode (White Clip through mode) L (open): Normal mode

Pin No.	Name	DC Voltage (typ.)	AC Voltage (typ.)	Interface equivalent circuit	Note
6	Carrier off mode selection	H: 5 V L: 0 V	—		<p>This terminal is selection of Carrier off-mode and Antenna SW driver output.</p> <p>High : Carrier ON Antenna SW High</p> <p>Low or Open : Carrier OFF Antenna SW Low</p>
7	4 MHz X'tal	4.3 V (External input mode) 2.7 V (Internal oscillation mode)	—	<p>Note1: Internal oscillation mode OFF Note2: External input mode OFF</p>	<p>As reference signal, either 4-MHz crystal resonator can be connected to this pin for internal oscillation or external signal can be input.</p> <p>Reference signal Mode can be selected pin 1.</p>
8	Channel select	H: 5 V L: 0 V	—		<p>This terminal is the selection of RF VCO oscillation frequency.</p> <p>Open or High : USA 3ch Low : USA 4ch</p>
9	Digital GND	(0 V)	—	—	Digital GND
10	P/S ratio set up	5V (Pin Open)	—		<p>P / S ratio is set up by connecting resistance with this terminal between GND.</p>
11	Digital Vcc	(5 V)	—	—	Digital Vcc

Pin No.	Name	DC Voltage (typ.)	AC Voltage (typ.)	Interface equivalent circuit	Note
12	Sound PLL loop filter	—	—		<p>Sound VCO oscillation frequency is compared with 4.5MHz, and the error is outputted by Charge pump.</p> <p>LPF for high frequency rejection is connected to this terminal. And the voltage for sound VCO control is generated.</p> <p>The reference frequency is 20.8 kHz.</p>
13	Analog Vcc	(5 V)	—		Analog Vcc
14	Antenna SW driver output	H: 4.1 V L: 0 V	—		<p>This terminal is a driver output for an Antenna SW switching and controlled by the terminal 6.</p> <p>The maximum output current is 15mA.</p>
15	RF signal output	3.2 V	93dB μ V		<p>RF signal output pin.</p> <p>Low-impedance emitter-follower output</p>
16	N.C.	—	—	—	

Explanation in each mode

1. Reference signal Mode selection (Pin 1)

As reference signal, either 4-MHz crystal resonator can be connected to this pin for internal oscillation or external signal can be input. Reference signal Mode can be selected pin 1. 4MHz and 3.579545MHz can be used for the frequency of an external input signal.

Voltage of pin 1	Reference signal mode
High or Open	4MHz External input
Middle	3.579545MHz External input
Low	Internal oscillation with 4MHz X' tal

2. Test mode selection (Pin 5)

Pin 5 is also used for switching test mode. Normally this pin is used at 0 V DC (used by AC coupling). White clip mode is prepared into test mode. (e.g. when modulation characteristics for near-100% modulation are being checked.)

Voltage of pin 5	Mode
High	Test mode
Middle	White Clip through mode (Test mode)
Low or Open	Normal mode

If the voltage of a terminal 5 becomes more than 1.2V, it will change to the test mode. Be careful of the influence of a noise etc.

3. Carrier off mode selection (Pin 6)

Pin 6 is selection of Carrier off-mode and Antenna SW driver output. In Carrier off mode, Supply current is saved by stopping Sound VCO.

Voltage of pin 6	RF&sound oscillation	Antenna SW driver output (pin 14)
High	ON	High
Low or Open	OFF	Low

When changing a carrier ON, RF output is muted the time of about 130 msec. Mute of RF output is for avoiding the influence of the noise by RF carrier frequency being unstable. At the time of Channel switching, RF output is muted similarly.

4. Channel selection (Pin 8)

Pin 8 is the selection of RF VCO oscillation frequency.

Voltage of pin 8	Channel
High or Open	USA 3ch (61.25MHz)
Low	USA 4ch (67.25MHz)

5. P/S ratio set up (Pin 16)

P / S ratio is set up by connecting resistance with pin 16 between GND. P / S ratio can be set as the range of -9dB to -17dB.

Maximum Ratings (Ta = 25°C)

The absolute maximum ratings of a semiconductor device are a set of specified parameter values, which must not be exceeded during operation, even for an instant.

If any of these rating would be exceeded during operation, the device electrical characteristics may be irreparably altered and the reliability and lifetime of the device can no longer be guaranteed.

Moreover, these operations with exceeded ratings may cause break down, damage and/or degradation to any other equipment.

Applications using the device should be designed such that each maximum rating will never be exceeded in any operating conditions. Before using, creating and/or producing designs, refer to and comply with the precautions and conditions set forth in this documents.

Characteristics	Symbol	Rating	Unit
Supply voltage	V_{CC}	6	V
Power dissipation (Note 1)	P_D	810	mW
Input terminal voltage	V_{IN}	$GND - 0.3 - V_{CC} + 0.3$	V
Operating temperature	T_{opr}	-20~75	°C
Storage temperature	T_{stg}	-55~150	°C

Note 1: Power dissipation in the IC alone. If the device is operated at $T_a > 25^\circ\text{C}$, this parameter must be derated by 6.5 mW per 1°C.

Electrical Characteristics (V_{CC} = 5.0 V, Ta = 25°C, When there is no indication of conditions f_p = 61.25 MHz)

	No.	Characteristics	Symbol	Min	Typ.	Max	Unit	Note
Entire IC	1-1	Supply voltage	V _{cc}	4.5	5.0	5.5	V	
	1-2	Operating frequency range	f _{op}	61.25	-	67.25	MHz	f _p frequency
	1-3	Supply current 1 (Normal mode)	I _{cc1}	38	45	51	mA	Normal moe,IANT SW=0mA
	1-4	Supply current 2 (Carrier off mode)	I _{cc2}	2.5	3.5	4.5	mA	Carrier off mode
Video Block	2-1-1	Video RF output level	V _o	90	93	96	dB μ V	50- Ω termination, staircase (B/W) signal, 0.5-V _{p-p} input
	2-1-2	Video RF output level (Difference of channel)	Δ V _o	-1.2	0.2	0.8	dB	50- Ω termination, staircase (B/W) signal, 0.5-V _{p-p} input, V _o (3ch) - V _o (4ch)
	2-2	Video modulation depth	mp	76	80	84	%	White signal:0.5V _{p-p} input
	2-3	White clipping level	mpMAX	88	92	96	%	White signal:1.0V _{p-p} input
	2-4	Differential gain	DG	-5	0	+5	%	10-step staircase signal: 0.5-V _{p-p} input (chroma signal = 20 IRE), 9th step
	2-5	Differential phase	DP	-5	0	+5	°	10-step staircase signal: 0.5-V _{p-p} input (chroma signal = 20 IRE), 9th step
	2-6	Video S/N ratio	mpS/N	50	51.5	-	dB	0.1 MHz~4.2 MHz, unweighted, 50% White signal input
	2-7	Video frequency response	f _v	-2.4	-0.4	1.6	dB	0.1 MHz~4.2 MHz, referenced to 1 MHz
	2-8	Average picture level drift	mp(APL)	-3	0	+3	%	10%~90% APL, referenced to 50%, variation in video modulation depth
	2-9	Sync crush level	Δ sync	-	1	3	%	{1 - (V _{sync} /V _{white}) × (100/40)}
	2-10	Chroma beat	V _c	-	-75	-70	dB	3.58MHz sine wave: 0.5-V _{p-p} input, Referenced to video carrier level, P/S ratio = -16dB
	2-11-1	Video RF 2nd harmonic	V _{2fp}	-	-35	-30	dB	Referenced to video carrier level
	2-11-2	Video RF 3rd harmonic	V _{3fp}	-	-33	-28	dB	Referenced to video carrier level
	2-11-3	Video RF 4th harmonic	V _{4fp}	-	-55	-50	dB	Referenced to video carrier level
	2-12	Video harmonic	V _{ph}	-	-53	-50	dB	1MHz sine wave: 0.5-V _{p-p} input, Referenced to f _p +1MHz level, Level of f _p +2MHz
	2-13-1	Video carrier frequency accuracy 1	Δ f _{p4}	-50	0	50	kHz	Reference frequency 4MHz, Internal oscillation mode, Series capacitance of crystal : 6pF
	2-13-2	Video carrier frequency accuracy 2	Δ f _{p358}	-0.008	-	+34	kHz	Reference frequency 3.579545MHz, External signal input mode

	No.	Characteristics	Symbol	Min	Typ.	Max	Unit	Note
Sound Block	3-1-1	Picture to Sound ratio	RP/S	-18	-16	-14	dB	P/S ratio: -16dB set-up, Connecting a 16k ohm resistor between pin 10 and GND. staircase (B/W) signal: 0.5-Vp-p input
	3-1-2	Picture to Sound ratio (Difference of channel)	Δ RP/S	-0.5	0	0.5	dB	P/S ratio: -16dB set-up, Connecting a 16k ohm resistor between pin 10 and GND. staircase (B/W) signal: 0.5-Vp-p input, RP/S (3ch) -RP/S (4ch)
	3-2-1	Maximum P/S ratio	RP/S max	-11	-9	-	dB	P/S ratio: maximum set-up, Pin 10 is open. staircase (B/W) signal: 0.5-Vp-p input
	3-2-2	Minimum P/S ratio	RP/S min	-	-18	-16	dB	P/S ratio: minimum set-up, Pin 10 is connected to GND. staircase (B/W) signal: 0.5-Vp-p input
	3-3	Sound modulation sensitivity	β FM	0.27	0.3	0.33	kHz/mV	1-kHz sine wave: 167 mVp-p input β FM = Δ f (kHz)/ 167 (mV)
	3-4-1	Sound S/N ratio 1	S/N(FM1)	51	52.5	-	dB	1-kHz sine wave input, \pm 25 kHz Dev. = 0dB, Inter Carrier demod., De-Emph = IN
	3-4-2	Sound S/N ratio 2 (with video signal)	S/N(FM2)	50	51.5	-	dB	1-kHz sine wave input, \pm 25 kHz Dev. = 0dB, Color bar signal: 0.5-Vp-p input, Inter Carrier demod., De-Emph = IN
	3-5	Sound distortion	THD	-	0.3	0.5	%	1-kHz sine wave: \pm 25kHz Dev.
	3-6	Sound frequency response	fs	-2	0	2	dB	100 Hz-100 kHz, 1-kHz reference
	3-7	Maximum FM deviation	Δ Dev	400	450	-	%	1-kHz sine wave input, THD<3%
	3-8-1	Sound RF 2nd harmonic	VSH1	-	-70	-65	dB	P/S ratio = -16dB set-up, Video carrier level reference
	3-8-2	Sound RF 3rd harmonic	VSH2	-	-75	-70	dB	P/S ratio = -16dB set-up, Video carrier level reference
	3-9-1	Sound carrier frequency accuracy 1	Δ fs4	-750	0	750	Hz	Reference frequency 4MHz, Internal oscillation mode, Series capacitance of crystal : 6 pF
	3-9-2	Sound carrier frequency accuracy 2	Δ fs358	-0.6	-	-	Hz	Reference frequency 3.579545MHz, External signal input mode
Logic Block	4-1-1	Input voltage Low level for channel selection	ViL1	0	-	1.7	V	Pin 8: Low:67.25MHz, Open,High:61.25MHz
	4-1-2	Input voltage High level for channel selection	ViH1	2	-	Vcc	V	Pin 8
	4-2-1	Input voltage Low level for Carrier off mode selection	ViL2	0	-	1.7	V	Pin 6 Low,Open : Carrier off , Antenna SW Out Low
	4-2-2	Input voltage High level for Carrier off mode selection	ViH2	2	-	Vcc	V	Pin 6 High : Carrier on , Antenna SW Out High
	4-3-1	Input voltage Low level for reference signal mode selection	ViL3	0	-	1.2	V	Pin 1 Low : Internal oscillation mode with 4MHz X'tal
	4-3-2	Input voltage Middle level for reference signal mode selection	ViM3	1.8	2.5	3.2	V	Pin 1 Middle : 3.58MHz External signal input mode
	4-3-3	Input voltage High level for reference signal mode selection	ViH3	3.8	-	Vcc	V	Pin 1 Open,High : 4MHz External signal input mode
	4-4	Threshold voltage for power-on reset	VRESET	2.5	2.8	3.1	V	
	4-5-1	Input voltage Low level for Test mode selection	ViL4	0	-	1.2	V	Pin 5 Low : Normal mode
	4-5-2	Input voltage High level for Test mode selection	ViH4	1.8	-	Vcc	V	Pin 5 High : Test mode

	No.	Characteristics	Symbol	Min	Typ.	Max	Unit	Note
	4-6	Output voltage Low level of Antenna SW driver	VOL	-	0	0.1	V	
	4-7	Output voltage High level of Antenna SW driver	VOH	3.6	4	4.3	V	15mA load
	5-1	Negative resistance of X'tal oscillator	RXO	-1	-	-	kΩ	
	5-2	Input signal level of external reference signal	Vosc	50	10	-	mVp-p	External reference signal input Mode

Input Waveforms

White signal

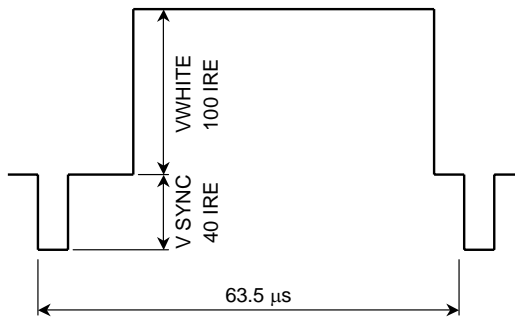

**Staircase (B/W) signal
APL50%**

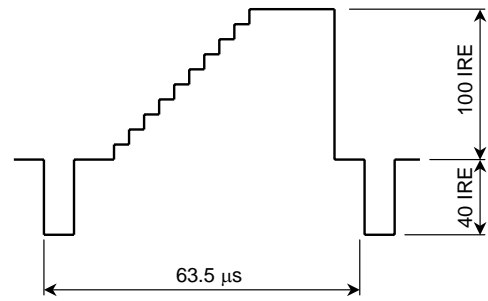

**Staircase (sub-carrier 20 IRE) signal
APL 50%**

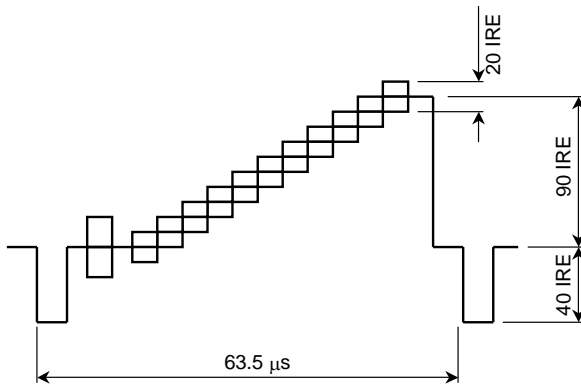

Input Waveforms may be simplified for explanatory purpose.

Test and Application Circuit

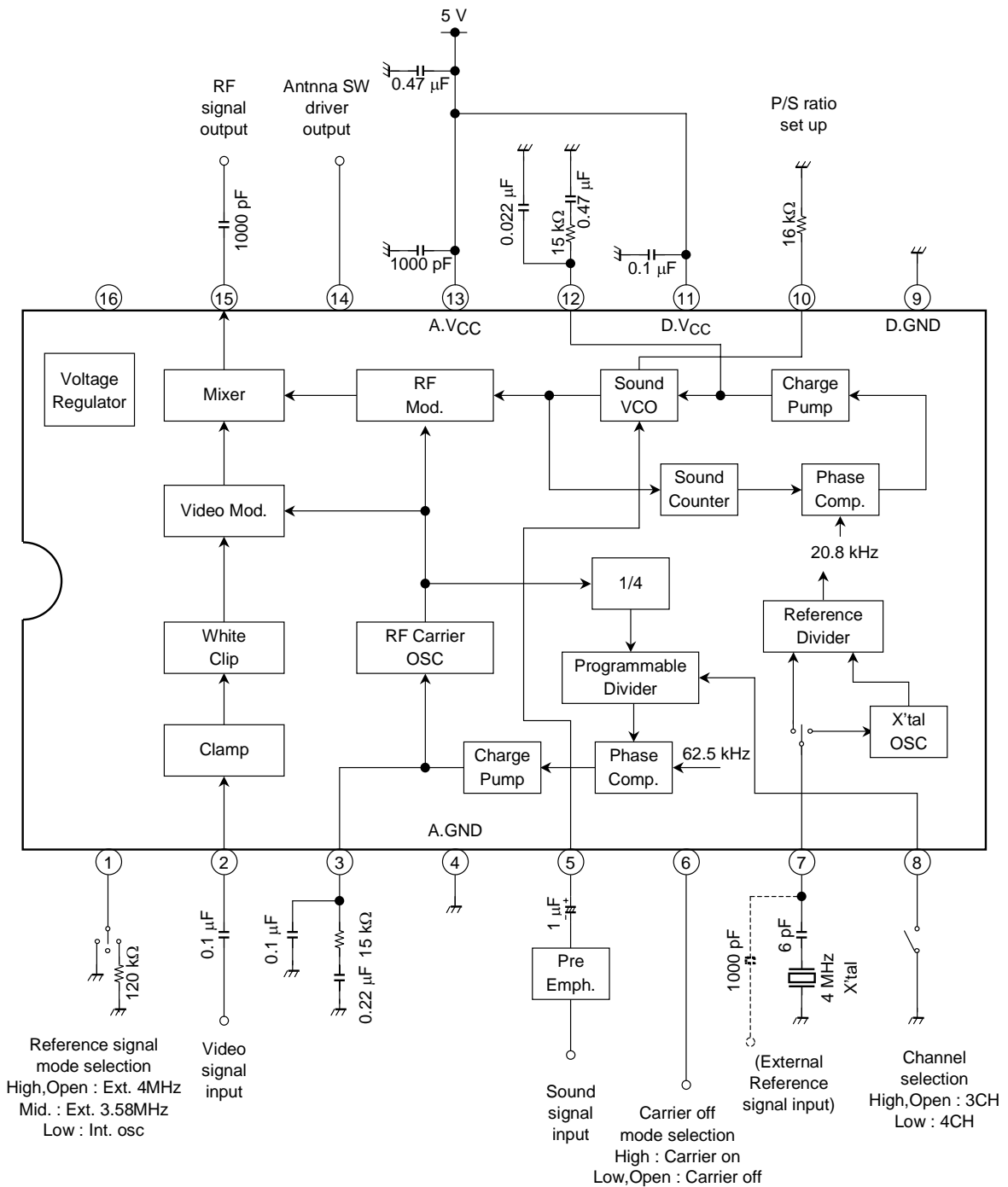

Components in the test circuits are only used to obtain and confirm the device characteristics. These components and circuits do not warrant to prevent the application equipment from malfunction or failure.

The application circuits shown in this document are provided for reference purposes only. Especially, a thorough evaluation is required on the phase of mass production design. Toshiba does not grant the use of any industrial property rights with these examples of application circuits.

Handling Precautions

1. Do not drive the device's power supply voltage High or Low until it is attached to an inspection board or similar test assembly. Attaching the device to, or removing it from the inspection board while it is powered on may damage the device or degrade its characteristics. The power supply voltage should not be applied suddenly. Any overshoot or chattering in the power supply may result in degradation of the IC's characteristics. A filter or similar protective component should be inserted on the power supply line.
2. If the voltage of a terminal 5(Sound signal input) becomes more than 1.2V, it will change to the test mode. Be careful of the influence of a noise etc.
3. The application circuits described in this document are merely intended as examples to enable the operation of the device to be evaluated. None of the peripheral circuit configurations shown or circuit constants specified are intended to be incorporated into application systems or used in designs for mass-produced equipment. Toshiba Corporation cannot assume responsibility for any damage arising from the use of any of these circuits. This is because the high-frequency characteristics of a device can vary according to a number of factors, including factors relating to the external components and the mounting pattern used. Therefore, the user must design external circuits according to the requirements of the specific application system, using this document as a reference only. The user must also test the application circuit's characteristics thoroughly. This document only guarantees device quality and characteristics as described herein; Toshiba Corporation cannot assume responsibility for any user's product design or application implementation.
4. Before attempting to use this product, the user should refer to the latest edition of the **Toshiba Semiconductor Reliability Handbook, Integrated Circuits** in order to gain a better understanding of the general principles governing the quality and reliability of Toshiba products and to learn how Toshiba seeks to enhance the management and control of product quality and reliability. The **Toshiba Semiconductor Reliability Handbook, Integrated Circuits** is also available on the semiconductor products information page of the **Toshiba Electronic Components and Materials** website at the following URL:
<http://www.semicon.toshiba.co.jp/eng/prd/common/index.html>.

(Last updated: Dec. 2003)

Package Dimensions

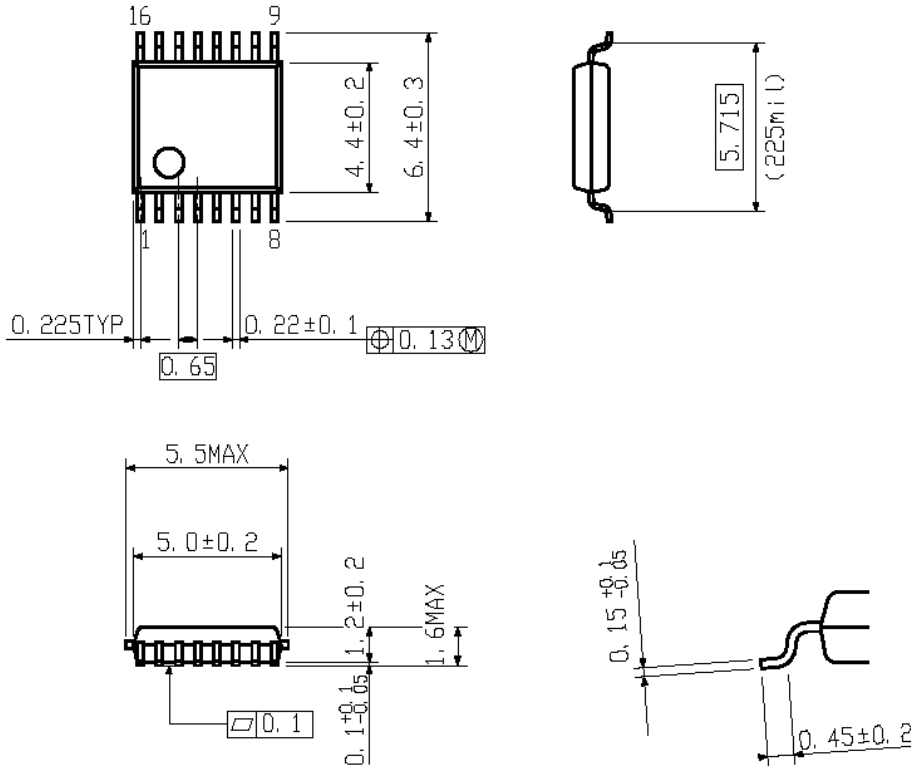

Weight: 0.07 g (typ.)

RESTRICTIONS ON PRODUCT USE

030619EBA

- The information contained herein is subject to change without notice.
- The information contained herein is presented only as a guide for the applications of our products. No responsibility is assumed by TOSHIBA for any infringements of patents or other rights of the third parties which may result from its use. No license is granted by implication or otherwise under any patent or patent rights of TOSHIBA or others.
- TOSHIBA is continually working to improve the quality and reliability of its products. Nevertheless, semiconductor devices in general can malfunction or fail due to their inherent electrical sensitivity and vulnerability to physical stress. It is the responsibility of the buyer, when utilizing TOSHIBA products, to comply with the standards of safety in making a safe design for the entire system, and to avoid situations in which a malfunction or failure of such TOSHIBA products could cause loss of human life, bodily injury or damage to property.
In developing your designs, please ensure that TOSHIBA products are used within specified operating ranges as set forth in the most recent TOSHIBA products specifications. Also, please keep in mind the precautions and conditions set forth in the "Handling Guide for Semiconductor Devices," or "TOSHIBA Semiconductor Reliability Handbook" etc..
- The TOSHIBA products listed in this document are intended for usage in general electronics applications (computer, personal equipment, office equipment, measuring equipment, industrial robotics, domestic appliances, etc.). These TOSHIBA products are neither intended nor warranted for usage in equipment that requires extraordinarily high quality and/or reliability or a malfunction or failure of which may cause loss of human life or bodily injury ("Unintended Usage"). Unintended Usage include atomic energy control instruments, airplane or spaceship instruments, transportation instruments, traffic signal instruments, combustion control instruments, medical instruments, all types of safety devices, etc.. Unintended Usage of TOSHIBA products listed in this document shall be made at the customer's own risk.
- The products described in this document are subject to the foreign exchange and foreign trade laws.
- TOSHIBA products should not be embedded to the downstream products which are prohibited to be produced and sold, under any law and regulations.