

## Audio/Video Switch Matrix

### Main Features

- I<sup>2</sup>C Bus Control
- Standby Mode with Interrupt Signal Output
- Video Section
  - 3 CVBS Inputs, 2 CVBS Outputs
  - 3 Y/C Inputs, 2 Y/C Outputs
  - 6 dB Gain on all CVBS/Y and C Outputs
  - Integrated 150  $\Omega$  Buffers
  - 2 RGB/FB Inputs, 1 Tri-state RGB/FB Output with 6 dB Adjustable Gain (from +3 dB to +9 dB)
  - Video Muting on all Outputs
  - 2 Slow Blanking Inputs/Outputs
  - Sync Bottom Clamp on all CVBS/Y and RGB Inputs, Average Clamp on C Inputs
  - Bandwidth: 15 MHz
  - Crosstalk: 50 dB Minimum
- Audio Section
  - 3 Stereo Inputs, 3 Stereo Outputs
  - Stereo-to-Mono Sound Capability
  - 0/6/9 dB Selectable Gain on one Stereo Input
  - Full Range Volume Control with Soft Control
  - Audio Muting on all Outputs

### Description

The STV6413 is a highly integrated I<sup>2</sup>C bus-controlled audio and video switch matrix, optimized for use in digital set-top box applications. It provides the audio and video routings required in a two SCART set-top box design.

In a TQFP64 (10 x 10 mm) package, the STV6413 is compatible with the STV6412A (TQFP64 14 x 14 mm) used for designing boards with two levels of integration.

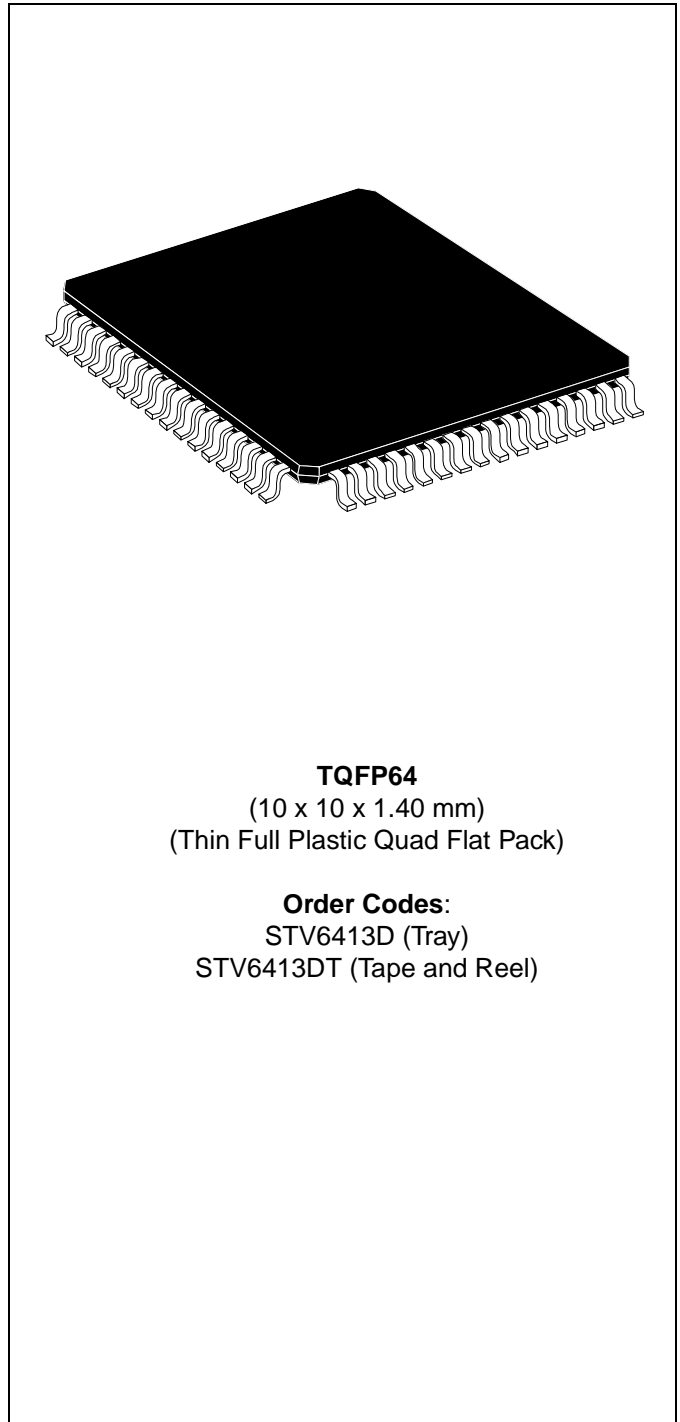

## Table of Contents

<b>Chapter 1</b>	<b>General Information</b> .....	<b>3</b>
1.1	I/O Pin Description .....	3
<b>Chapter 2</b>	<b>Electrical Characteristics</b> .....	<b>8</b>
2.1	Absolute Maximum Ratings .....	8
2.2	Thermal Data .....	8
2.3	Latch-up Data .....	8
2.4	Electrical Characteristics .....	9
<b>Chapter 3</b>	<b>I<sup>2</sup>C Bus Selection</b> .....	<b>15</b>
3.1	I <sup>2</sup> C Bus Addresses .....	15
3.2	Power-on Reset — Bus Register Initial Conditions .....	20
<b>Chapter 4</b>	<b>Input/Output Groups</b> .....	<b>22</b>
<b>Chapter 5</b>	<b>Application Diagram</b> .....	<b>25</b>
<b>Chapter 6</b>	<b>Package Mechanical Data</b> .....	<b>26</b>
<b>Chapter 7</b>	<b>Revision History</b> .....	<b>27</b>

# 1 General Information

Figure 1: STV6413 Pinout Diagram

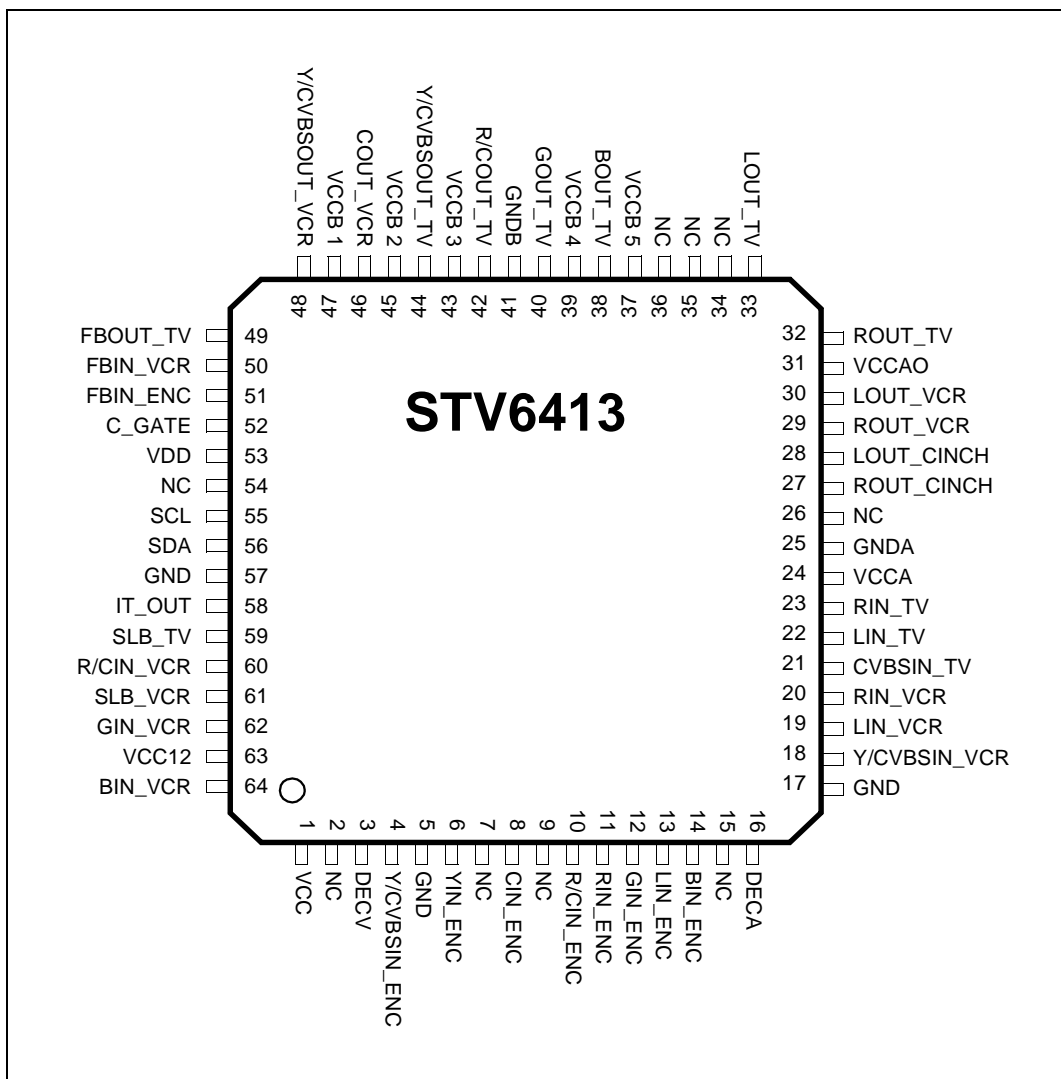

## 1.1 I/O Pin Description

Table 1: Pin Description (Sheet 1 of 3)

Pin No.	Name	Function
1	VCC	+5 V Supply
2	NC	Not connected
3	DECV	Video Decoupling Capacitor
4	Y/CVBSIN_ENC	Y/CVBS Input from Encoder
5	GND	Ground
6	YIN_ENC	Y Input from Encoder
7	NC	Not connected

Table 1: Pin Description (Sheet 2 of 3)

Pin No.	Name	Function
8	CIN_ENC	Chroma Input from Encoder
9	NC	Not connected
10	R/CIN_ENC	Red/Chroma Input from Encoder
11	RIN_ENC	Audio Right, Input from Encoder
12	GIN_ENC	Green Input from Encoder
13	LIN_ENC	Audio Left, Input from Encoder
14	BIN_ENC	Blue Input from Encoder
15	NC	Not Connected
16	DECA	Audio Decoupling Capacitor
17	GND	Ground
18	Y/CVBSIN_VCR	Y/CVBS Input from VCR SCART
19	LIN_VCR	Audio Left, Input from VCR SCART
20	RIN_VCR	Audio Right, Input from VCR SCART
21	CVBSIN_TV	CVBS Input from TV SCART
22	LIN_TV	Audio Left, Input from TV SCART
23	RIN_TV	Audio Right, Input from TV SCART
24	VCCA	Audio Supply Voltage - or - Audio Supply Decoupling
25	GNDA	Audio Ground
26	NC	Not Connected
27	ROUT_CINCH	Audio Right Output to Cinch
28	LOUT_CINCH	Audio Left Output to Cinch
29	ROUT_VCR	Audio Right Output to VCR SCART
30	LOUT_VCR	Audio Left Output to VCR SCART
31	VCCAO	Audio Output Supply Voltage - or - Main Audio Supply Voltage
32	ROUT_TV	Audio Right Output to TV SCART
33	LOUT_TV	Audio Left Output to TV SCART
34	NC	Not connected
35	NC	Not connected
36	NC	Not connected
37	VCCB5	Video Output Buffer Supply Pin
38	BOUT_TV	Blue Output to TV SCART
39	VCCB4	Video Output Buffer Supply Pin
40	GOUT_TV	Green Output to TV SCART
41	GNDB	Video Buffer Ground
42	R/COUT_TV	Red/Chroma Output to TV SCART

Table 1: Pin Description (Sheet 3 of 3)

Pin No.	Name	Function
43	VCCB3	Video Output Buffer Supply Pin
44	Y/CVBSOUT_TV	Y/CVBS Output to TV SCART
45	VCCB2	Video Output Buffer Supply Pin
46	COUT_VCR	Chroma Output to VCR SCART
47	VCCB1	Video Output Buffer Supply Pin
48	Y/CVBSOUT_VCR	Y/CVBS Output to VCR SCART
49	FBOUT_TV	Fast Blanking Output to TV SCART
50	FBIN_VCR	Fast Blanking Input from VCR SCART
51	FBIN_ENC	Fast Blanking Input from Encoder
52	C_GATE	External MOS Command for C_VCR bidirectional mode
53	VDD	+5 V I <sup>2</sup> C Supply
54	NC	Not connected
55	SCL	I <sup>2</sup> C Bus Clock
56	SDA	I <sup>2</sup> C Bus Data
57	GND	Ground Digital
58	IT_OUT	Interrupt Output
59	SLB_TV	Slow Blanking Input/Output from TV SCART
60	R/CIN_VCR	Red Input (or C Input) from VCR SCART
61	SLB_VCR	Slow Blanking Input/Output from VCR SCART
62	GIN_VCR	Green Input from VCR SCART
63	VCC12	+12 V Supply
64	BIN_VCR	Blue Input from VCR SCART

Figure 2: STV6413 Block Diagram

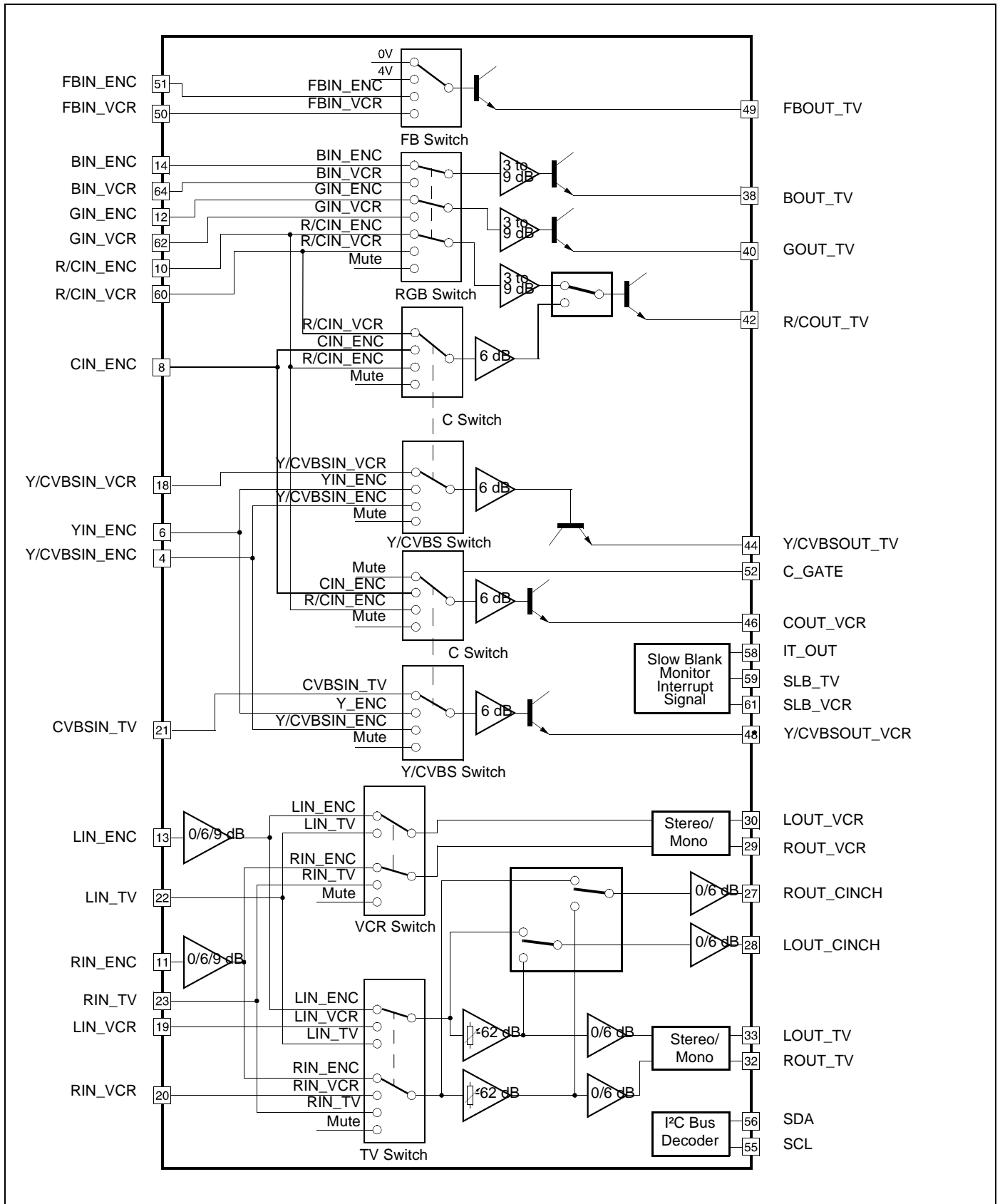
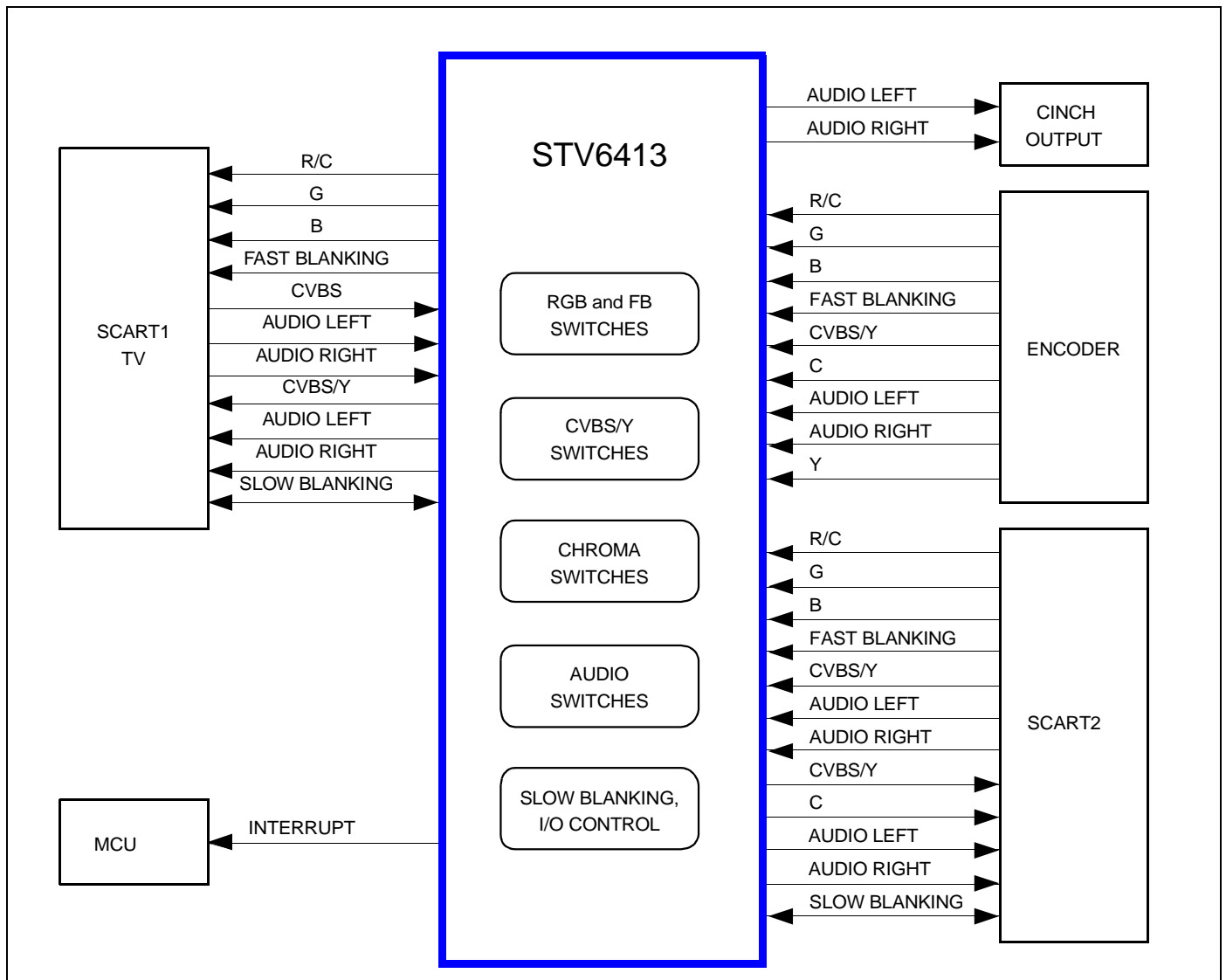

Figure 3: STV6413 Functional Diagram



## 2 Electrical Characteristics

### 2.1 Absolute Maximum Ratings

Symbol	Parameter		Value	Unit
$V_{CC12}$	Supply voltage for Slow Blanking sections		13.2	V
$V_{CCAO}$	Supply voltage for Audio Drivers		13.2	V
$V_{CCA}$	Supply voltage for Digital Audio sections		10	V
$V_{DD}$	Supply voltage for Digital sections		6	V
$V_{CC}$ , $V_{CCBI}$	Supply voltage for Video sections		6	V
$V_{IN}$	Input Voltage at Pin (in reference to GND)	Audio pins Video pins Bus pins Slow Blanking pins	0, $V_{CCA}$ 0, $V_{CC}$ or $V_{CCBI}$ 0, 5.5 0, $V_{CC12}$	V
$V_{ESD}$	Maximum ESD Voltage allowed. (Human Body Model: 100 pF capacitor discharged through 1.5 kOhm serial resistor)		±4	kV
$T_{OPER}$	Ambient Operating Temperature		0 to +70	°C
$T_{STG}$	Storage Temperature		-20 to +150	°C

### 2.2 Thermal Data

Symbol	Parameter	Value	Unit
$R_{thJC}$	Junction-to-Case Thermal Resistance		°C/W
$R_{thJA}$	Junction-to-Ambient Thermal Resistance <sup>1</sup>	48	°C/W
$T_J$	Maximum Recommended Junction Temperature		°C

1. Measured on 4-layer application board.

### 2.3 Latch-up Data

At an ambient temperature of 25 °C, all pins meet the following specifications:

- $I_{trigger} = 200$  mA or  $I_{trigger} = -200$  mA.
- Pin 58 (IT\_OUT) does not meet this specification and the trigger current must be limited to 100 mA.



## 2.4 Electrical Characteristics

$T_{AMB} = 25^{\circ} C$ ,  $V_{CCA0} = 12 V$ ,  $V_{CC} = 5 V$ ,  $V_{CC12} = 12 V$ ,  $V_{DD} = 5 V$

$R_{GA} = 600 \Omega$ ,  $R_{GV} = 50 \Omega$ ,  $R_{LOUTA} = 10 k\Omega$ ,  $R_{LOUTV} = 150 \Omega$  (unless otherwise specified).

### Supply Section

Symbol	Parameter	Test Conditions	Min.	Typ.	Max.	Unit
$V_{DD}$	Digital Supply Voltage		4.75	5	5.25	V
$V_{CCA0}$	Audio Operating Supply Voltage	- Decoupling capacitor on $V_{CCA}$ - Connected to $V_{CCA}$	11.2 8.5	12 9	12.8 9.5	V
$V_{CC}$	Video Operating Supply Voltage		4.75	5	5.25	V
$V_{CC12}$	Slow Blanking Control Supply Voltage		11.2	12	12.8	V

### Active Mode (All channels ON)

Symbol	Parameter	Test Conditions	Min.	Typ.	Max.	Unit
$I_{DD}$	Digital Supply Current	$V_{DD} = 5 V$		4.5	10	mA
$I_{CCA}$	Audio Supply Current	$V_{CCA0} = 12 V$ , No Load		9	15	mA
$I_{CCV}$	Total Video Supply Current ( $V_{CC} + V_{CCB1} + V_{CCB2} + V_{CCB3} + V_{CCB4} + V_{CCB5}$ )	$V_{CC} = 5 V$ , No Load		43	60	mA
$I_{CC12}$	12 V Supply Current	$V_{CC12} = 12 V$ SLB input mode SLB output mode, No Load		0 2.5	1 4	mA

### Standby Mode (All channels OFF)

Symbol	Parameter	Test Conditions	Min.	Typ.	Max.	Unit
$I_{DD}$	Digital Supply Current	$V_{DD} = 5 V$		4.5	10	mA
$I_{CCASTD}$	Audio Supply Current	$V_{CCA0} = 12 V$ , No Load		3		mA
$I_{CCVSTD}$	Total Video Supply Current	$V_{CC} = 5 V$ , No Load		1		mA

### Audio Section

Symbol	Parameter	Test Conditions	Min.	Typ.	Max.	Unit
SVR100	Supply Voltage Rejection	$V_{RIPPLE} = 500 mV_{RMS}$ at 100 Hz, Gain = 0 dB DECA filter cap = 47 $\mu F$ DECA filter cap = 220 $\mu F$	60	70 80		dB
SVR1K	Supply Voltage Rejection	$V_{RIPPLE} = 500 mV_{RMS}$ at 1 kHz, Gain = 0 dB	70	80		dB

Symbol	Parameter	Test Conditions	Min.	Typ.	Max.	Unit
V <sub>INDC</sub>	Input DC Level	V <sub>CCA</sub> = 9 V		V <sub>CCA/2</sub>		V
V <sub>INAC</sub>	Input Signal Amplitude				2	V <sub>RMS</sub>
R <sub>IN</sub>	Input Resistance		30	50		kΩ
R <sub>INmatch</sub>	Input Resistance Matching			±2	±10	%
F <sub>RANGE</sub>	Bandwidth	-3 dB, 0.5 V <sub>RMS</sub> , R <sub>LOAD</sub> = 10 kΩ, Gain = 0 dB	50			kHz
Flatness	Spread of Gain in Audio Band	-0.5 V <sub>RMS</sub> , 20 Hz to 20 kHz, Gain = 0 dB			0.5	dB
CS	Channel Separation, from audio inputs Between L & R of TV outputs	V <sub>IN</sub> = 0.5 V <sub>RMS</sub> at 1 kHz on one input, R <sub>LOAD</sub> = 10 kΩ, Gain = 0 dB	80 70	90 74		dB dB
C <sub>i</sub>	Channel Isolation from video inputs	V <sub>IN</sub> = 1 V <sub>PP</sub> at 15 kHz on one point		85		dB
V <sub>OUT</sub>	Output DC Level	V <sub>CCA</sub> = 9 V		V <sub>CCA/2</sub>		V
V <sub>OFF</sub>	DC Offset Change	Switching between inputs		1	±15	mV
R <sub>OUT</sub>	Output Resistance			60	120	Ω
PHD	Phase Difference	1 V <sub>RMS</sub> input on each input channel at 1 kHz			3	° deg.
ASN	S/N Ratio	V <sub>IN</sub> = 1 V <sub>RMS</sub> at 1 kHz input weighted CCIR 468-4 quasi peak, Gain = 0 dB	80	90		dB
eNI	Equivalent RMS Input Voltage Noise	BW = 20 Hz, 20 kHz Flat, Gain = 0 dB		5		μV
G <sub>0</sub>	0 dB Gain	0.5 V <sub>RMS</sub> , R <sub>LOAD</sub> = 10 kΩ, Gain = 0 dB	-0.5		+0.5	dB
G <sub>STEP</sub>	Gain Step	-62 dB to +6 dB (see Figure 2)		2		dB
G <sub>MATCH1</sub>	Gain matching between different inputs of one output	V <sub>IN</sub> = 0.5 V <sub>RMS</sub> at 1 kHz, Gain = 0 dB	-0.5		0.5	dB
G <sub>MATCH2</sub>	Gain matching between Left/Right outputs of one input channel	V <sub>IN</sub> = 0.5 V <sub>RMS</sub> at 1 kHz, Gain = 0 dB	-0.5		0.5	dB
THD <sub>0</sub> THD <sub>6</sub> THD <sub>9</sub>	Total Harmonic Distortion ENC Input at 0 dB ENC Input at 6 dB ENC Input at 9 dB	V <sub>OUT</sub> = 0.5 V <sub>RMS</sub> at 1 kHz, LPF at 80 kHz, Volume Level Adjustment = 0 dB		0.01 0.01 0.01	0.05 0.05 0.05	%
V <sub>CL</sub>	Output Clipping Level	THD = 0.2%, 1 kHz	2.1	2.3		V <sub>RMS</sub>
R <sub>L</sub>	Output Load Resistance	V <sub>IN</sub> = 1 V <sub>RMS</sub> , THD = 0.3%, Gain = 0 dB	2	2.25		kΩ
Mute	Mute Suppression	V <sub>IN</sub> = 0.5 V <sub>RMS</sub> , on one point	90			dB

## Video Section

Symbol	Parameter	Test Conditions	Min.	Typ.	Max.	Unit
$V_{DCIN}$	DC Input Level	Bottom Sync Pulse		2		V
$I_{CLAMP}$	Clamping Current	at $V_{DCIN} - 400$ mV	1	2		mA
$I_{LEAK}$	Input Leakage Current	$V_{IN} = V_{DCIN} + 1$ V		1	10	$\mu$ A
$C_{IN}$	Input Capacitance			2		pF
$V_{IN}$	Max Input Signal	$V_{CC} = 5$ V		1.5		$V_{PP}$
DYN	Dynamic Output Signal	$V_{CC} = 5$ V		3		$V_{PP}$
BW	Bandwidth at -3 dB - Y/CVBS - RGB	$V_{IN} = 1 V_{PP}$ $V_{IN} = 1 V_{PP} V_{INC} = \text{muted}$	12 12	15 15		MHz
Flatness	Spread of Gain in Video Band (15 kHz - 5 MHz) - Y/CVBS - RGB	$V_{IN} = 1 V_{PP}$ $V_{IN} = 1 V_{PP} V_{INC} = \text{Muted}$			$\pm 0.5$ $\pm 0.5$	dB
CTi	Crosstalk Isolation between Input Channel	$V_{IN} = 1 V_{PP}$ at 4.43 MHz on one point		60		dB
CTo	Crosstalk Isolation between Output Channel	$V_{IN} = 1 V_{PP}$ at $f = 4.43$ MHz, on one point, $R_{LOAD} = 150\Omega$		50		dB
$R_{OUT}$	Output Resistance			5	10	$\Omega$
$G_{RGB}$	Gain at RGB outputs	$V_{IN} = 1 V_{pp}$ , Gain = 6 dB	5.5	6	6.5	dB
$G_{RGBM}$	Gain matching between R, G, B	$V_{IN} = 1 V_{pp}$ , Gain = 6 dB	-0.3	0	0.3	dB
$G_{RGBSTEP}$	Step of Gain	3 dB to 6 dB	0.75	1	1.25	dB
$G_{YCVBS}$	Gain on Y, CVBS channels	$V_{IN} = 1 V_{PP}$	5.5	6	6.5	dB
$G_{YCVBSM}$	Gain matching between Y, CVBS inputs	$V_{IN} = 1 V_{PP}$	-0.5	0	0.5	dB
$DC_{OUT}$	DC Output Voltage	Bottom sync pulse		0.6		V
DPHI	Differential Phase	$V_{IN} = 1 V_{PP}$ at 4.43 MHz		1	5	$^{\circ}$ deg.
DG	Differential Gain	$V_{IN} = 1 V_{PP}$ at 4.43 MHz		1	5	%
Mute	Mute Suppression	$V_{IN} = 1 V_{PP}$ at 5 MHz on one point	55			dB
LNL	Luminance non-linearity			0.3	3	%
VSN	Video S/N Ratio	Refer to <a href="#">Note 1</a>	65			dB

Note: 1  $S/N = 20 \log (V_{OUT} \text{ Black to White} = 0.7 V_{PP} / V_{Noise} (mV_{RMS}) \text{ weighted CCIR 567})$ .

## Chroma Section

Symbol	Parameter	Test Conditions	Min.	Typ.	Max.	Unit
$V_{DCIN}$	DC Input Level			3		V
$R_{IN}$	Input Resistance		30	50		k $\Omega$
$C_{IN}$	Input Capacitance			2		pF
$V_{IN}$	Max Input Signal			1.5		$V_{PP}$
DYN	Dynamic Output Signal			3		$V_{PP}$
$DC_{OUT}$	DC Output VCR Voltage			2.2		V
CBW	Chroma Bandwidth	$C_{IN} = 1 V_{PP}$ at -3 db	10			MHz
CTi	Crosstalk Isolation between Input Channel	$V_{IN} = 1 V_{PP}$ at 4.43 MHz on one input		55		dB
CTo	Crosstalk Isolation between Output Channel	$V_{IN} = 1 V_{PP}$ at 4.43 MHz on one input, $R_{LOAD} = 150 \Omega$		50		dB
$R_{OUT}$	Output Resistance			5	10	$\Omega$
$G_{OUTC}$	Gain at OUTC	$V_{IN} = 1 V_{pp}$	5.5	6	6.5	dB
$G_{CM}$	Gain Matching between C inputs	$V_{IN} = 1 V_{PP}$	-0.5	0	0.5	dB
Mute	Mute Suppression	$V_{IN} = 1 V_{PP}$ at 4.43 MHz on one input	55			dB
CToYdel	Chroma to Luma Delay, Source Y/C	$V_{PP}$ at 4.43 MHz,			20	ns
CToYdel	Chroma to Luma Delay, Source Y/C				20	ns

## Slow Blanking Section

Symbol	Parameter	Test Conditions	Min.	Typ.	Max.	Unit
<b>Input Mode</b>						
SLBlow	Input Low Level Threshold		2.5	3.25	4	V
SLBhigh	Input High Level Threshold		7.5	8.25	9	V
$I_{IN}$	Input Current			50	100	$\mu$ A
<b>Output Mode</b>						
SLBlow	Output Low Level (Int. TV)		0	0.02	1.5	V
SLBmed	Output Medium Level (Ext. 16:9)		5	5.75	6.5	V
SLBhigh	Output High Level (Ext. 4:3)		10	11	12	V

## Fast Blanking Section

Symbol	Parameter	Test Conditions	Min.	Typ.	Max.	Unit
<b>Input Mode</b>						
FB <sub>low/high</sub>	Input Low/High Level Threshold		0.4	0.7	0.9	V
I <sub>IN</sub>	Input Current			2	10	μA
<b>Output Mode</b>						
FB <sub>LOW</sub>	Output Low Level	R <sub>LOAD</sub> = 150 Ω			0.5	V
FB <sub>HIGH</sub>	Output High Level		3.0	3.4	3.8	V
FB <sub>DEL</sub>	Fast Blanking RGB delay	At 50% on digital RGB transients, at 2 V on FB rise transient, at 1 V on FB fall, C <sub>LOAD</sub> = 10pF maximum		15		ns
FB <sub>TRANS</sub>	FB Transitions at FB output - Rise Time - Fall Time	C <sub>LOAD</sub> = 10 pF maximum between 10% and 90% between 90% and 10%		10 10		ns

## C\_Gate Function Output Section

Symbol	Parameter	Test Conditions	Min.	Typ.	Max.	Unit
C_GATE-H	Pull-up Resistor Value to V <sub>CCB1</sub>			20		kΩ
C_GATE-L	Output Low Level	I <sub>IN</sub> = 0 mA I <sub>IN</sub> = 1 mA			0.3 0.7	V

Interrupt Output Section<sup>1</sup>

Symbol	Parameter	Test Conditions	Min.	Typ.	Max.	Unit
IT-Leak	High Level Leakage	External pull-up to 5 V			10	μA
IT-Low	Output Low Level (Active)	I <sub>IN</sub> = 0 mA I <sub>IN</sub> = 1 mA			0.3 0.7	V

1. When bit IT Enable is set, the interrupt is forced to a low level when a change is detected on slow blanking inputs. It can be used in standby mode to wake up the microprocessor. It is released when the I<sup>2</sup>C bus register is read.

I<sup>2</sup>C Bus Characteristics

Symbol	Parameter	Test Conditions	Min.	Typ.	Max.	Unit
<b>SCL</b>						
V <sub>IL</sub>	Low Level Input Voltage		-0.3		1.5	V
V <sub>IH</sub>	High Level Input Voltage		2.3		5.5	V
I <sub>LI</sub>	Input Leakage Current	V <sub>IN</sub> = 0 to 5.5 V	-10	0	10	μA
<b>SDA</b>						
V <sub>IL</sub>	Low Level Input Voltage		-0.3		1.5	V
V <sub>IH</sub>	High Level Input Voltage		2.3		5.5	V
I <sub>LI</sub>	Input Leakage Current	V <sub>IN</sub> = 0 to 5.5 V	-10	0	10	μA
C <sub>I</sub>	Input Capacitance				10	pF
t <sub>R</sub>	Input Rise Time	1.5 V to 3 V			1	μs
t <sub>F</sub>	Input Fall Time	3 V to 1.5 V			300	ns
V <sub>OL</sub>	Low Level Output Voltage	I <sub>OL</sub> = 3 mA			0.4	V
t <sub>F</sub>	Output Fall Time	3 V to 1.5 V			250	ns
C <sub>L</sub>	Load Capacitance				400	pF
<b>Timing</b>						
t <sub>LOW</sub>	Clock Low Period		4.7			μs
t <sub>HIGH</sub>	Clock High Period		4			μs
t <sub>SU,DAT</sub>	Data Setup Time		250			ns
t <sub>HD,DAT</sub>	Data Hold Time		0		340	ns
t <sub>SU,STO</sub>	Setup Time from Clock High to Stop		4			μs
t <sub>BUF</sub>	Start Setup Time following a Stop		4.7			μs
t <sub>HD,STA</sub>	Start Hold Time		4			μs
t <sub>SU,STA</sub>	Start Setup Time following Clock Low to High Transition		4.7			μs

Figure 4: I<sup>2</sup>C Bus Timing

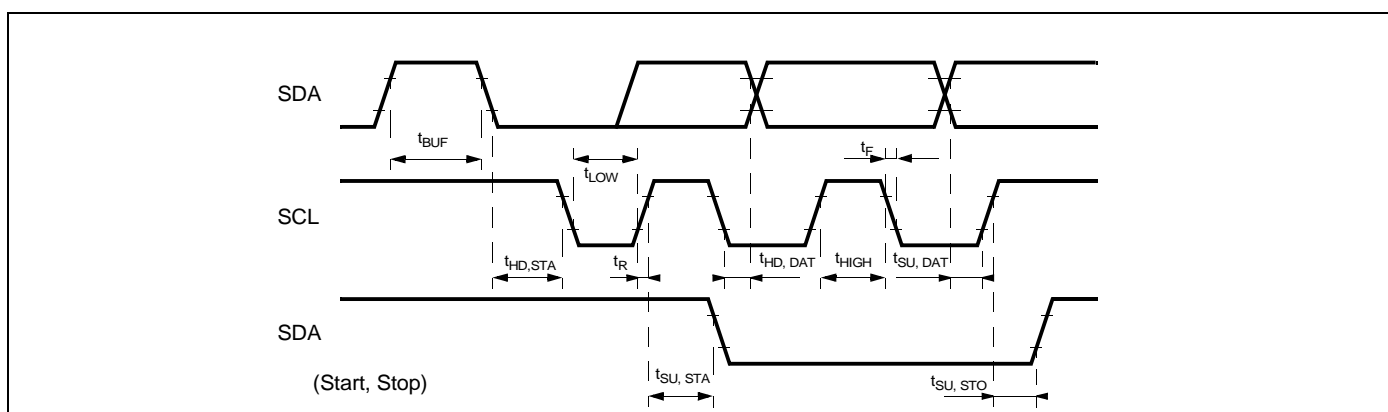

### 3 I<sup>2</sup>C Bus Selection

Data transfers follow the usual I<sup>2</sup>C format; i.e. after the start condition (S), a 7-bit slave address is sent, followed by an eight-bit data direction bit (W). An 8-bit sub-address is sent to select a register, followed by an 8-bit data word to be included in the register. The IC's I<sup>2</sup>C bus decoder enables the automatic incrementation mode in write mode.

#### String Format

Write only mode (S = Start condition, P = Stop condition, A = Acknowledge)

S	Slave Address	0	A	Sub-address	A	Data	A	P
---	---------------	---	---	-------------	---	------	---	---

Read only mode

S	Slave Address	1	A	Data	A	P
---	---------------	---	---	------	---	---

Slave Address

Address	A7	A6	A5	A4	A3	A2	A1
Value	1	0	0	1	0	1	1

Auto Increment Mode

S	Slave Address	0	A	Sub-address	A	Data0	A	Data1	A	...	Data n	A	P
						Sub-address		Sub-address + 1			Sub-address + N		

#### 3.1 I<sup>2</sup>C Bus Addresses

Write Address: 1001 0110 = 96(hex), Read Address: 1001 0111 = 97(hex)

**Table 2: Input Signal Summary (Write Mode)**

Reg. Add.	Data							
	d7	d6	d5	d4	d3	d2	d1	d0
<b>Audio</b>								
00h	TV Stereo Mono	TV 0/6 dB	TV Volume-62 dB to 0 dB - 2 dB steps					Soft Volume Mode
01h	VCR Stereo Mono	Not Used (See <a href="#">Note 1</a> )	VCR Audio Switch Control	CINCH Audio Gain	TV/CINCH Audio Switch Control			
<b>Video</b>								
02h	VCR Chroma muted	VCR Video and Chroma Switch Control			TV Chroma muted	TV Video and Chroma Switch Control		
03h	RGB and FB Tri-state	RGB Gain			RGB Switch Control		Fast Blanking Mode/Input Selection	

Table 2: Input Signal Summary (Write Mode)

Reg. Add.	Data							
	d7	d6	d5	d4	d3	d2	d1	d0
<b>Miscellaneous</b>								
04h	IT Enable	SLB Mode	Not Used (See Note 1)	VCR-C Output Control	VCR-C Gate Control	Not Used (See Note 1)	Not Used (See Note 1)	TV R or C Output Selection
05h	VCR Slow Blanking		TV Slow Blanking		ENC Audio Input Gain 0/6/9 dB		VCR R/C sub Clamp	ENC R/C sub Clamp
<b>Standby</b>								
06h	Not Used (See Note 1)	TV Outputs	CINCH Outputs	VCR Outputs	Not Used (See Note 1)	TV Inputs	VCR Inputs	ENC Inputs

Note: 1 At register address 06h, bits marked "Not Used" must be set to "1". All other bits marked "Not Used" must be set "0".

Table 3: TV Audio Output

Reg. Add.	Description	Bits	Data								Comments
			d7	d6	d5	d4	d3	d2	d1	d0	
00h	Soft Volume Change	1	X X	X X	X X	X X	X X	X X	X X	0 1	Active Disabled
	Level Adjustment	5	X X	X X	0 1	0 1	0 1	0 1	0 1	X X	0 dB -62 dB (-2 dB/step)
	6 dB Extra Gain	1	X X	0 1	X X	X X	X X	X X	X X	X X	0 dB +6 dB
	TV Stereo or Mono Mode	1	0 1	X X	X X	X X	X X	X X	X X	X X	0 = Stereo 1 = Mono



Table 4: Audio Selection &amp; VCR Audio Output

Reg. Add.	Description	Bits	Data								Comments
			d7	d6	d5	d4	d3	d2	d1	d0	
01h	TV & CINCH Audio Output Selection	3	X	X	X	X	X	0	0	0	Muted
			X	X	X	X	X	0	0	1	Encoder L/R selected
			X	X	X	X	X	0	1	0	VCR L/R selected
			X	X	X	X	X	0	1	1	Not allowed
X			X	X	X	X	1	0	0	TV L/R selected	
X			X	X	X	X	1	0	1	Not allowed	
X			X	X	X	X	1	1	0	Not allowed	
			X	X	X	X	0	X	X	X	0 dB
	CINCH Audio Gain	1	X	X	X	X	1	X	X	X	Follow TV Gain
01h	VCR Audio Output Selection	2	X	X	0	0	X	X	X	X	Muted
			X	X	0	1	X	X	X	X	Encoder L/R selected
			X	X	1	0	X	X	X	X	TV L/R selected
			X	X	1	1	X	X	X	X	Not allowed
01h	VCR Stereo or Mono Mode	1	0	X	X	X	X	X	X	X	0 = Stereo
			1	X	X	X	X	X	X	X	1 = Mono

Table 5: TV &amp; VCR Video Selection

Reg. Add.	Description	Bits	Data								Comments
			d7	d6	d5	d4	d3	d2	d1	d0	
02h	TV Video Output Selection	3	X	X	X	X	X	0	0	0	Y/CVBS muted & Chroma muted
			X	X	X	X	X	0	0	1	Y/CVBS_ENC & R/C_ENC
			X	X	X	X	X	0	1	0	Y_ENC & C_ENC
			X	X	X	X	X	0	1	1	Y/CVBS_VCR & R/C_VCR
			X	X	X	X	X	1	0	0	Not allowed
			X	X	X	X	X	1	0	1	Not allowed
			X	X	X	X	X	1	1	0	Not allowed
			X	X	X	X	1	1	1	Not allowed	
02h	TV Chroma Output Control	1	X	X	X	X	0	X	X	X	Chroma defined by d2d1d0
			X	X	X	X	1	X	X	X	Chroma force to mute
02h	VCR Video Output Selection	3	X	0	0	0	X	X	X	X	Y/CVBS muted & Chroma muted
			X	0	0	1	X	X	X	X	Y/CVBS_ENC & R/C_ENC
			X	0	1	0	X	X	X	X	Y_ENC & C_ENC
			X	0	1	1	X	X	X	X	CVBS_TV & Chroma muted
			X	1	0	0	X	X	X	X	Not allowed
			X	1	0	1	X	X	X	X	Not allowed
			X	1	1	0	X	X	X	X	Not allowed
			X	1	1	1	X	X	X	Not allowed	
02h	VCR Chroma Output Control	1	0	X	X	X	X	X	X	X	Chroma defined by d6d5d4
			1	X	X	X	X	X	X	X	Chroma force to mute

Table 6: RGB &amp; Fast Blanking Outputs

Reg. Add.	Description	Bits	Data								Comments											
			d7	d6	d5	d4	d3	d2	d1	d0												
03h	Fast Blanking Control	2	X	X	X	X	X	X	0	0	FB forced to low level	0	0	FB forced to high level	0	1	FB from Encoder	1	0	FB from VCR	1	1
	RGB Selection	2	X	X	X	X	0	0	X	X	Muted	X	X	RGB_ENC selected	X	X	RGB_VCR selected	X	X	Not allowed	X	X
	RGB Gain	2	X	X	0	0	X	X	X	X	+6 dB gain	X	X	+5 dB gain	X	X	+4 dB gain	X	X	+3 dB gain	X	X
			X	X	0	1	X	X	X	X	+0 dB extra gain	X	X	+3 dB for weak input signals	X	X		X	X			
	RGB and FB Control	1	0	X	X	X	X	X	X	X	RGB and FB outputs high impedance state	X	X	RGB and FB outputs active	X	X		X	X			
1			X	X	X	X	X	X	X		X	X		X		X	X					

Table 7: Miscellaneous Control

Reg. Add.	Description	Bits	Data								Comments					
			d7	d6	d5	d4	d3	d2	d1	d0						
04h	R/C TV Output Selection	1	X	X	X	X	X	0	0	0	Red signal selected	0	0	Chroma signal selected	0	1
	C_Gate Output Control	1	X	X	X	X	0	0	0	X	High level	X	X	Low level	0	0
	C_VCR Output Control	1	X	X	X	0	X	0	0	X	Tri-state mode (high impedance)	X	X	Active	0	0
			X	X	X	1	X	0	0	X	Normal Mode	X	X	SLB TV is driven by SLB VCR	0	0
	Slow Blanking Mode	1	X	0	X	X	X	0	0	X	Normal Mode	X	X	SLB TV is driven by SLB VCR	0	0
IT Enable	1	0	X	X	X	X	0	0	X	No interrupt flag	X	X	IT enable	0	0	
		1	X	X	X	X	0	0	X		X	X				

Table 8: Slow Blanking &amp; Inputs Control

Reg. Add.	Description	Bits	Data								Comments
			d7	d6	d5	d4	d3	d2	d1	d0	
05h	Encoder R/Csub Clamp	1	X X	X X	X X	X X	X X	X X	X X	0 1	Bottom level clamp Average level clamp
	VCR R/Csub Clamp	1	X X	X X	X X	X X	X X	X X	0 1	X X	Bottom level clamp Average level clamp
	Encoder Input Level Adjustment	2	X X X	X X X	X X X	X X X	0 0 1	0 1 0	X X X	X X X	0 dB for normal audio inputs +6 dB for weak audio inputs +9 dB for weak audio inputs
	Slow Blanking TV SCART	2	X X X X	X X X X	0 0 1 1	0 1 0 1	X X X X	X X X X	X X X X	X X X X	Input mode only Output < 2 V Output 16/9 format Output 4/3 format
	Slow Blanking VCR SCART	2	0 0 1 1	0 1 0 1	X X X X	X X X X	X X X X	X X X X	X X X X	X X X X	Input mode only Output < 2 V Output 16/9 format Output 4/3 format

Table 9: Standby Modes

Reg. Add.	Description	Bits	Data								Comments
			d7	d6	d5	d4	d3	d2	d1	d0	
06h	ENC Inputs	1	1 1	X X	X X	X X	1 1	X X	X X	0 1	Inputs active Inputs disabled
	VCR Inputs	1	1 1	X X	X X	X X	1 1	X X	0 1	X X	Inputs active Inputs disabled
	TV Inputs	1	1 1	X X	X X	X X	1 1	0 1	X X	X X	Inputs active Inputs disabled
	VCR Outputs	1	1 1	X X	X X	0 1	1 1	X X	X X	X X	Audio & Video Outputs ON Audio & Video Outputs OFF
	CINCH Outputs	1	1 1	X X	0 1	X X	1 1	X X	X X	X X	Audio & Video Outputs ON Audio & Video Outputs OFF
	TV Outputs	1	1 1	0 1	X X	X X	1 1	X X	X X	X X	Audio & Video Outputs ON Audio & Video Outputs OFF
	Full Stop		1	1	1	1	1	1	1	1	Only I <sup>2</sup> C bus and slow blanking detection parts are supplied.

Table 10: Output Signals (Read Mode)

Reg. Add.	Description	Bits	Data								Comments	
			d7	d6	d5	d4	d3	d2	d1	d0		
	Slow Blanking TV SCART	2	X	X	X	X	X	X	X	0	1	Input < 2 V Input 16/9 format Input 4/3 format
	Slow Blanking VCR SCART	2	X	X	X	X	0	1	X	X	X	Input < 2 V Input 16/9 format Input 4/3 format
	Interrupt Flag	1	X	X	X	0	X	X	X	X	X	No change since read One change has been detected (refer to <a href="#">Note 1</a> )

Note: 1 The Interrupt Flag will be cleared when this register is read. To prepare for a new interrupt, a “1” must be re-written in the IT Enable bit (Reg. 04, d7).

### 3.2 Power-on Reset — Bus Register Initial Conditions

Power-on Reset is active when the supply  $V_{DD}$  is less than 3.5 volts. Non-significant bits (X) are pre-set to “0”.

Reg. Add.	Data								Comments
	d7	d6	d5	d4	d3	d2	d1	d0	
00h	0	0	0	0	0	0	0	0	Audio TV and Cinch outputs are in Stereo Mode, 0 dB Gain Adjustment.
01h	0	0	0	0	0	0	0	0	TV, Cinch and VCR audio outputs are muted. VCR output is in Stereo Mode.
02h	0	0	0	0	0	0	0	0	VCR, TV video outputs are muted.
03h	0	0	0	0	0	0	0	0	Fast Blanking is forced to ‘0’. RGB outputs are muted and in high impedance.
04h	0	0	0	0	0	0	0	0	C_GATE is high. C_VCR is high impedance.
05h	0	0	0	0	0	0	0	0	Encoder and VCR R/Csub Bottom Level Clamp, RGB outputs 6 dB Gain, and Slow Blanking parts are in read mode.
06h	0	0	0	0	0	0	0	0	All internal blocks are ON.

Figure 5: Volume Control Characteristics

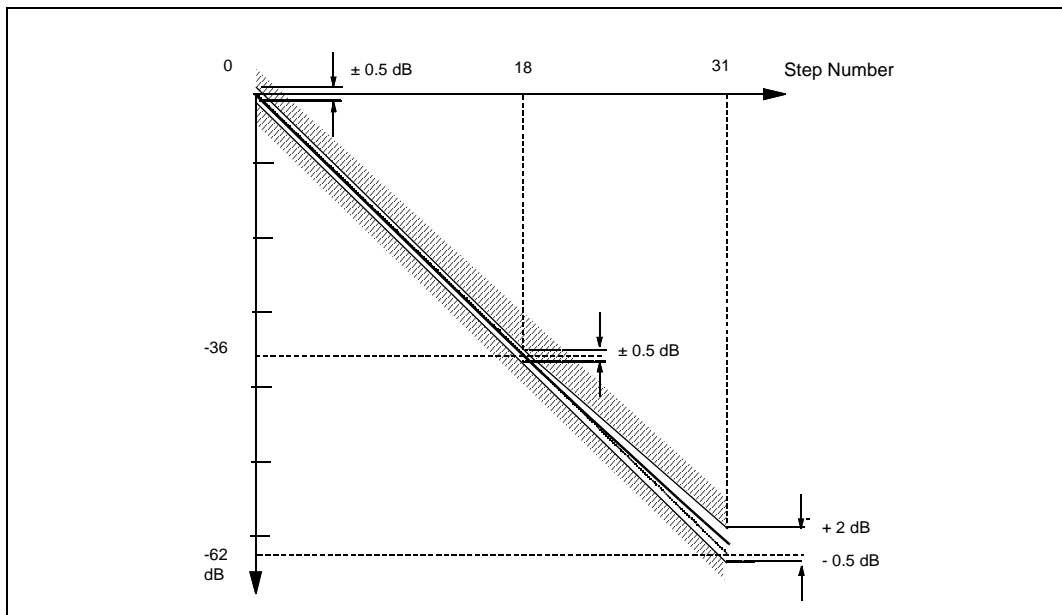

# 4 Input/Output Groups

**Figure 6: Bottom Clamped Video Inputs (Pins 4, 6, 12, 14, 18, 21, 62 and 64)**

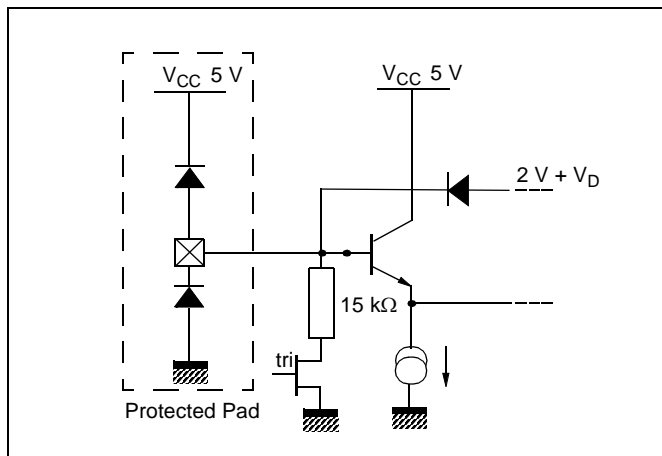

**Figure 9: Fast Blanking Inputs (Pins 50 and 51)**

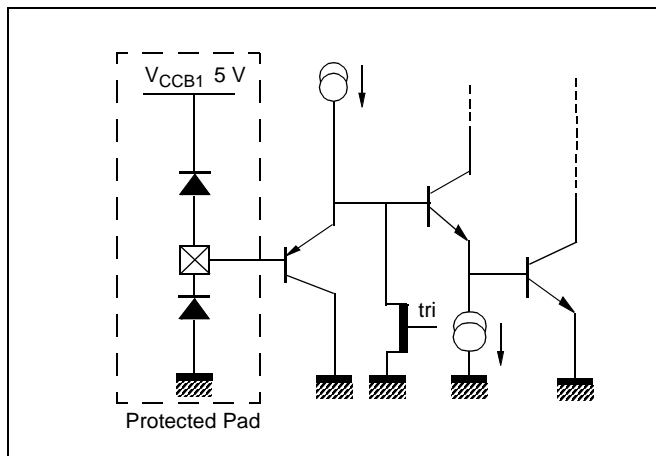

**Figure 7: R/C Clamped Video Inputs (Pins 10 and 60)**

R/C inputs may be configured either as a bottom clamped input or as an average clamped input. In either case, the simplified input schematic is very close to one of the graphics shown above.

**Figure 10: Average Clamped Video Inputs (Pin 8)**

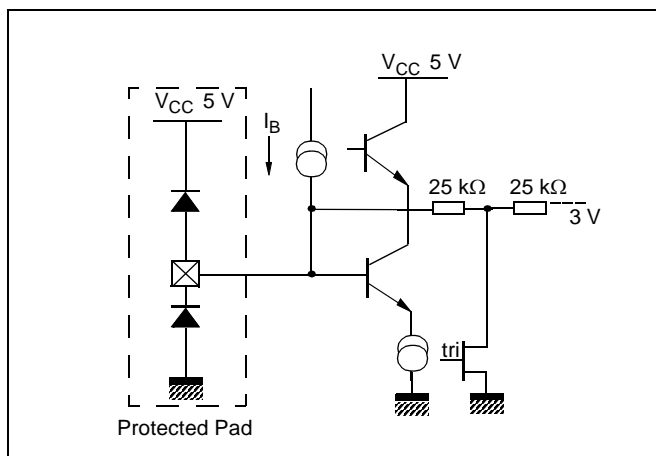

**Figure 8: Fast Blanking Output (Pin 49)**

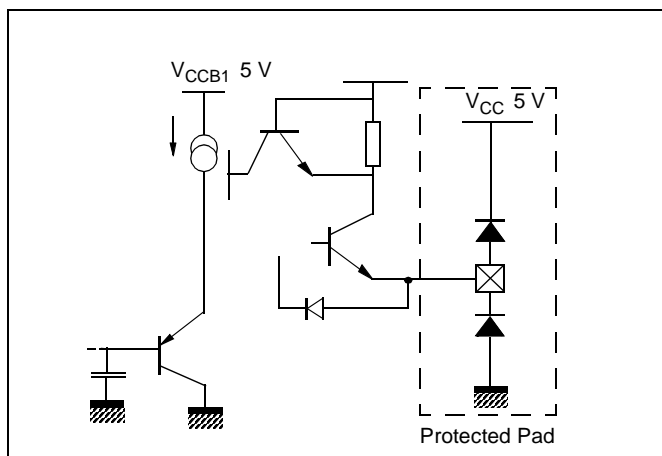

**Figure 11: Cgate Logical Output (Pin 52)**

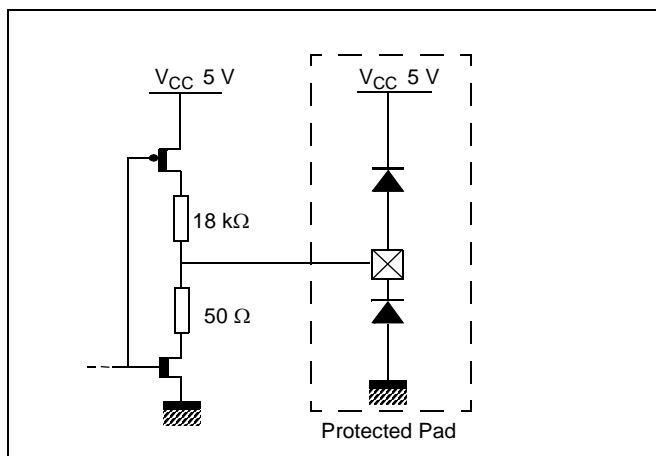

**Figure 12: Video Outputs**  
(Pins 38, 40, 42, 44, 46 and 48)

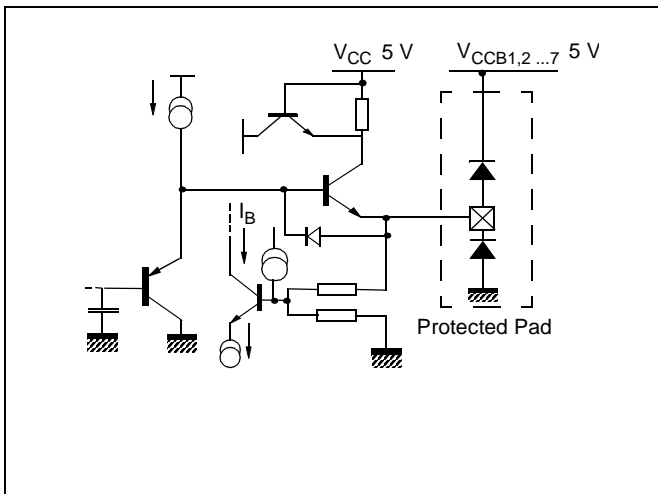

**Figure 15: Audio Outputs**  
(Pins 27, 28, 29, 30, 32 and 33)

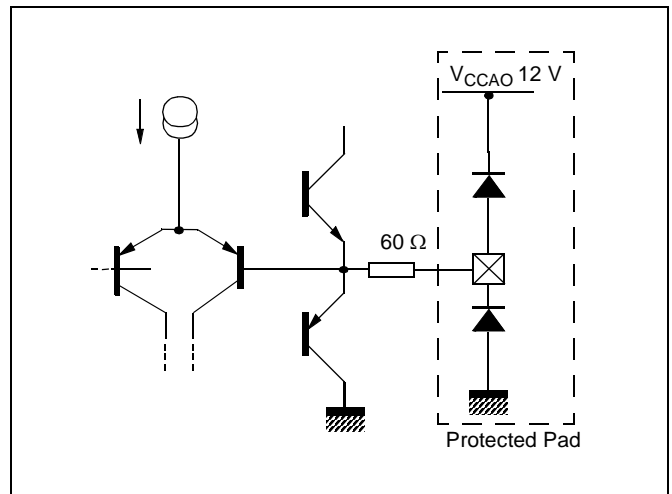

**Figure 13: Audio Inputs**  
(Pins 11, 13, 19, 20, 22 and 23)

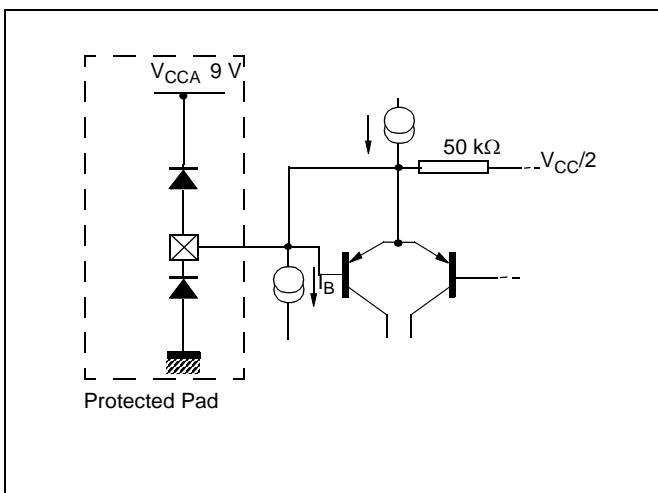

**Figure 16: Interrupt Output**  
(Pin 58)

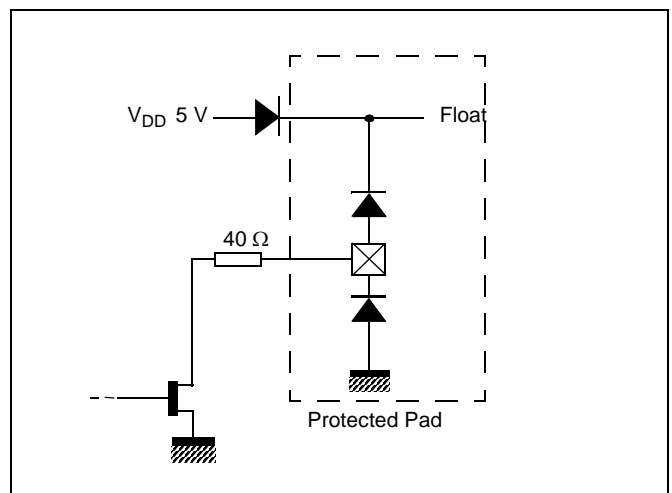

**Figure 14: Slow Blanking I/O** (Pins 59 and 61)

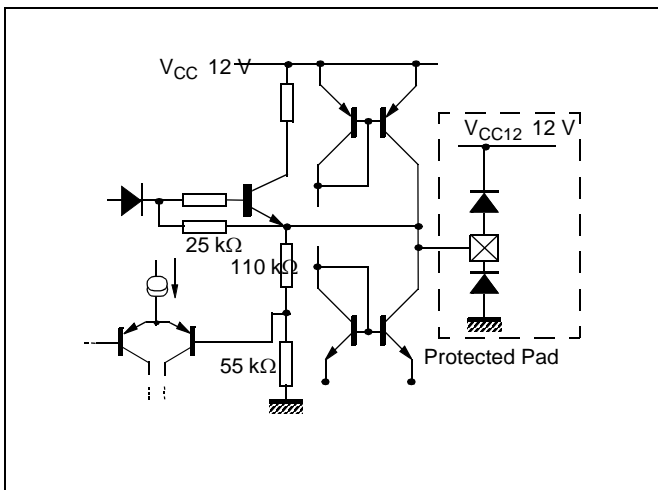

**Figure 17: I<sup>2</sup>C Bus (SDA) (Pin 56)**

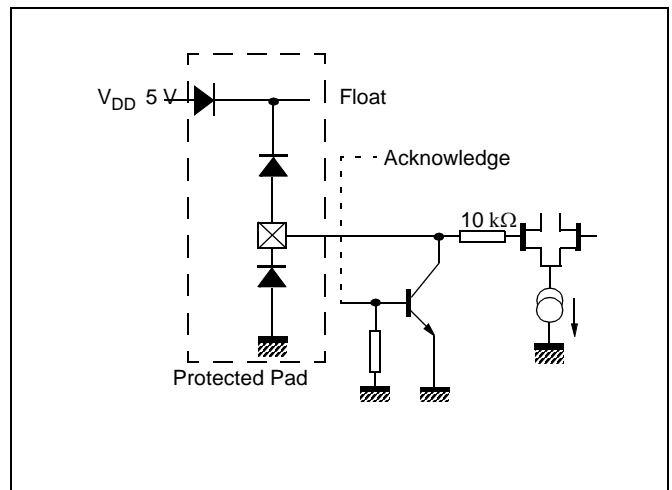

Figure 18: I<sup>2</sup>C Bus (SCL) (Pin 55)

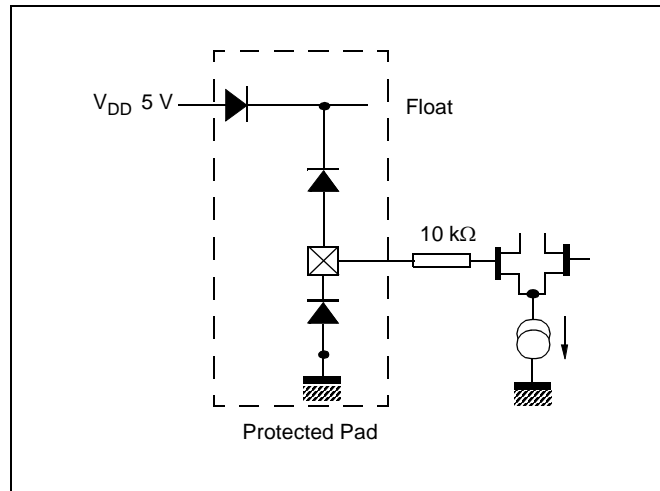
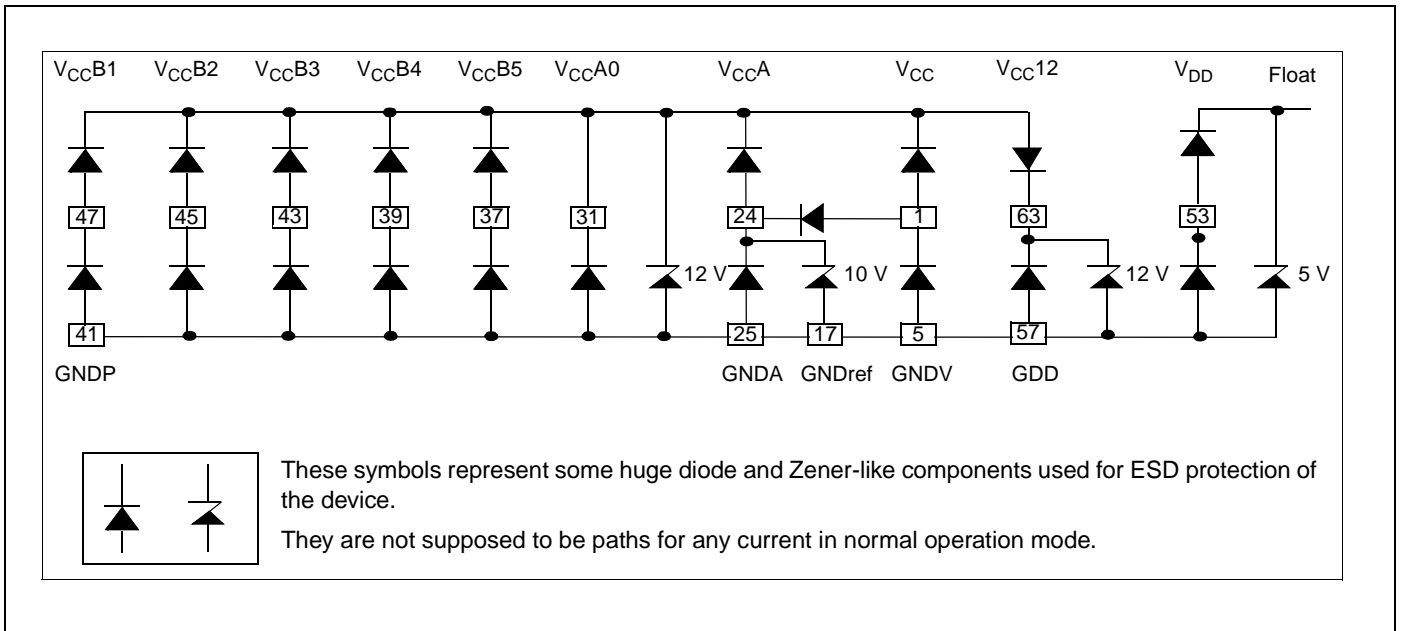

Figure 19: Power Supply Connection





# 5 Application Diagram

Figure 20: STV6413 Application Diagram

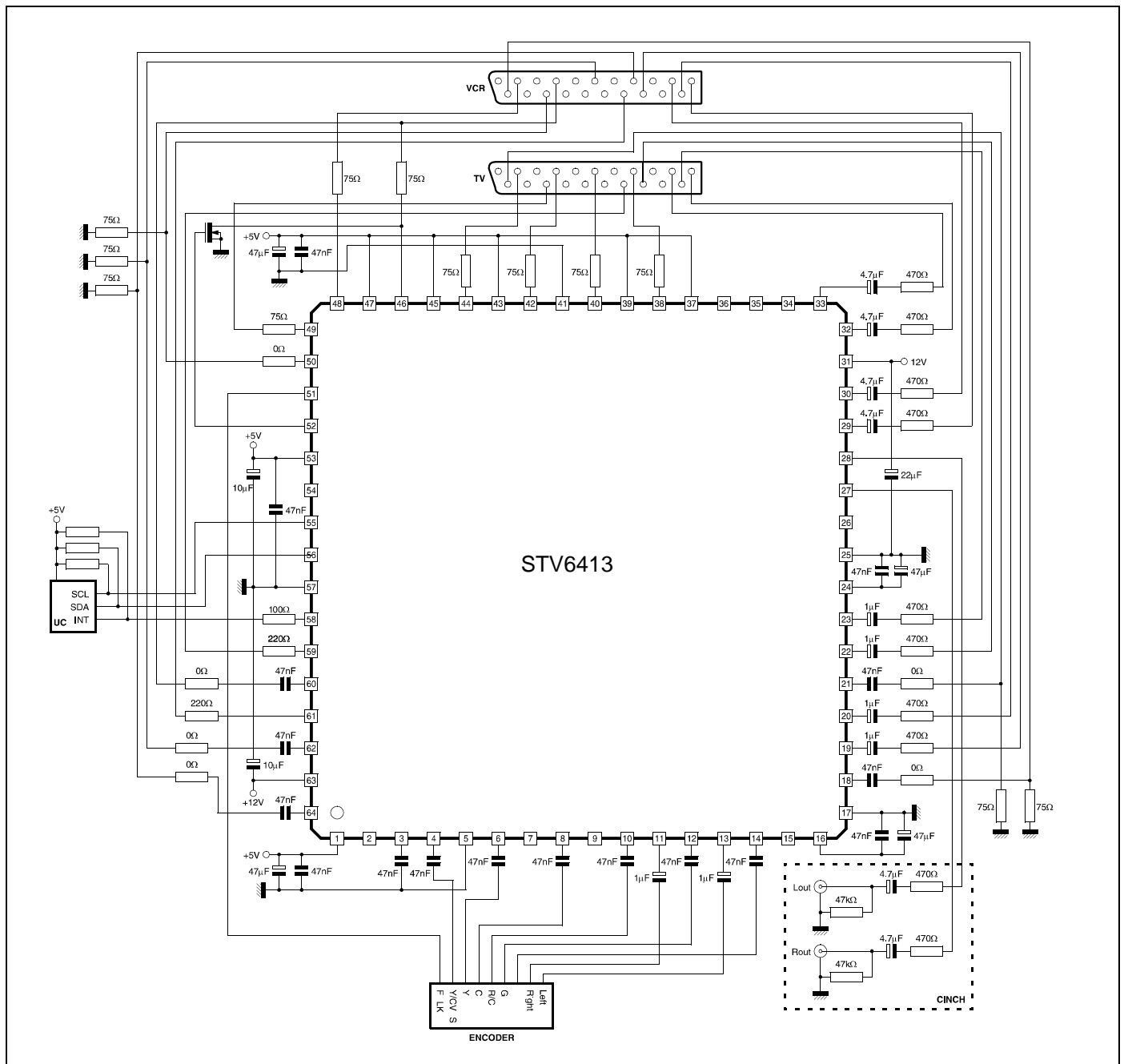

Note: For more details refer to STV6412A Application Note.

## 6 Package Mechanical Data

Figure 21: 64 Pin, Thin Full Plastic Quad Flat Pack (TQFP)

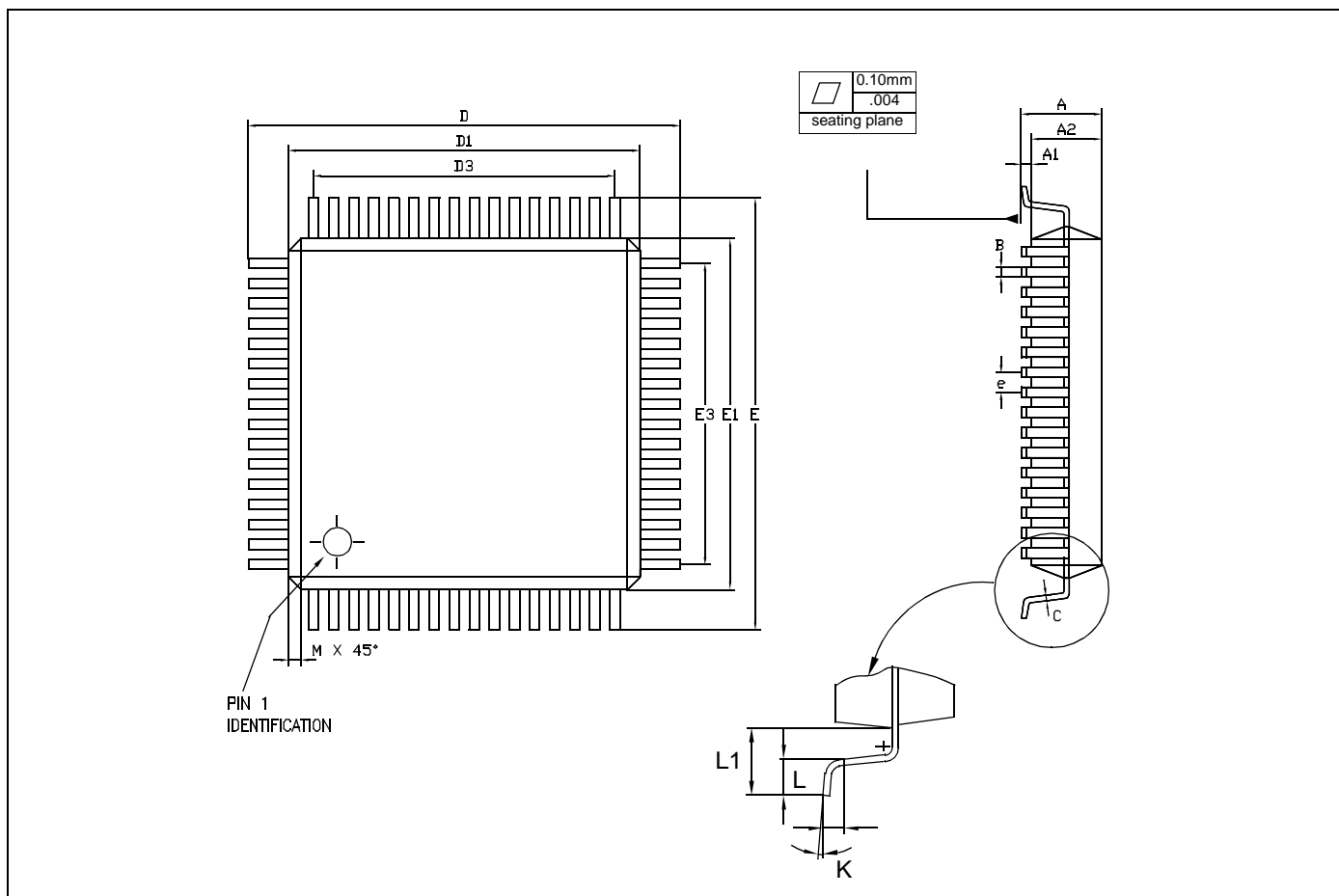

Dim.	mm			Inches		
	Min.	Typ.	Max.	Min.	Typ.	Max.
A			1.60			0.063
A1	0.05		0.15	0.002		0.006
A2	1.35	1.40	1.45	0.053	0.055	0.057
b	0.17	0.22	0.27	0.007	0.009	0.011
C	0.09		0.20	0.004		0.008
D		12.00			0.472	
D1		10.00			0.394	
E		12.00			0.472	
E1		10.00			0.394	
e		0.50			0.020	
K	0°	3.5°	7°	0°	3.5°	7°
L	0.45	0.60	0.75	0.018	0.024	0.030
L1		1.00			0.039	
	Number of Pins					
N	64		ND	16	NE	16

## 7 Revision History

Revision	Main Changes	Date
1.0	First Issue	Sept. 2001
1.1	Pin List updated.	Dec. 2001
1.2	STV6413 Product Preview updated to Datasheet. Order codes updated. Note added to <a href="#">Section 2.2: Thermal Data on page 8</a> . Test Conditions updated for Total Harmonic Distortion values in <a href="#">Section : Audio Section on page 9</a> .	March 2002
1.3	Modification of <a href="#">Note 1 on page 16</a> .	July 2002

Information furnished is believed to be accurate and reliable. However, STMicroelectronics assumes no responsibility for the consequences of use of such information nor for any infringement of patents or other rights of third parties which may result from its use. No license is granted by implication or otherwise under any patent or patent rights of STMicroelectronics. Specifications mentioned in this publication are subject to change without notice. This publication supersedes and replaces all information previously supplied. STMicroelectronics products are not authorized for use as critical components in life support devices or systems without express written approval of STMicroelectronics.

The ST logo is a registered trademark of STMicroelectronics

All other names are the property of their respective owners

© 2004 STMicroelectronics - All rights reserved

STMicroelectronics GROUP OF COMPANIES

Australia - Belgium - Brazil - Canada - China - Czech Republic - Finland - France - Germany - Hong Kong - India - Israel - Italy  
- Japan - Malaysia - Malta - Morocco - Singapore - Spain - Sweden - Switzerland - United Kingdom - United States

[www.st.com](http://www.st.com)