

5 Megapixel mobile imaging processor

Data Brief

Features

- Supports 2 mutually exclusive SMIA profile 2 compliant sensors of up to 5 Megapixel resolution^(a)
- Interfaces
 - Sensor interface: 2 x SMIA CCP Class 2^(b) receivers (640Mbit/s)
 - Host interface: SMIA CCP Class 1^(b) transmitter (416Mbit/s) or ITU (8-bit CCIR interface, up to 80MHz)
 - Control interface: I²C (400kHz)
- Enhanced video processor
 - Noise and defect filtering, color reconstruction, sharpness enhancement, 4-channel lens shading correction and barrel distortion correction
 - Statistic processor for automatic exposure, automatic white balance and auto-focus control
 - General purpose input/outputs (GPIOs) for controlling external actuators
- 2 video pipes for full frame-rate concurrent viewfinder and video/still capture. Single shot (e.g. flashgun) thumbnail generation
 - Gamma correction programmable for both CRT and LCD displays
 - Color correction matrix
 - Digital zoom: Smooth 16X downscale capability with up-scale capability to 4X
- Output formats: JPEG, YUV4:2:2, YUV4:2:0, Planar YUV4:2:0 (up to CIF), RGB888, RGB565, RGB444
- 4:2:0 JPEG compression with programmable quantization matrix and target file size

- JPEG operations up to 30 fps at 2 Megapixel resolution, up to 20 fps at 3 Megapixel resolution, and up to 12.5 fps at 5 Megapixel resolution
- Interleaved video modes (concurrent viewfinder and video/still capture)
 - ‘Alternate frame’ mode up to 15 fps
 - ‘Single frame’ mode up to 30 fps
- Image rotation/mirroring/flip support for viewfinder (up to CIF)
- Independent host interface transmitter clock, generated by an embedded PLL - frequency selectable by host
- Synchronised flash gun control with red-eye reduction (pre-flash and main-flash strobes for high-power LED or Xenon strobe control)
- Enhanced multi-zone auto-focus (supporting up to 9 zones with programmable weighting)

Description

The STV0986 is an ultra low power megapixel digital image processor designed to fit into mobile applications. The STV0986 contains advanced image correction, noise reduction techniques and a smooth digital zoom facility, resulting in exceptional image quality in today's multi-megapixel images. The STV0986 supports 2 SMIA sensors, flashgun (LED or Xenon), auto-focus and programmable general purpose IOs for additional external actuators. The internal buffer and versatile clock manager within the STV0986 accommodates a wide range of data-rates between the sensors, the STV0986 and the host.

Applications

- Mobile phone
- PDA
- Wireless security camera

a. SMIA 1.0 functional specification version 1.0
<http://www.smia-forum.org/>

b. SMIA 1.0 CCP2 Specification version 1.0

Technical specifications

Table 1. Technical specifications

Technology	90nm CMOS
Sensor	SMIA compliant sensors up to 5 Megapixels.
Frame rate	Up to 30fps: – @ 2MP JPEG + CIF RGB565 – @ VGA YUV422 – @ CIF RGB888 + QCIF YUV422 Up to 20fps @ 3MP JPEG + CIF RGB565 Up to 12.5fps – @ 5MP JPEG + CIF RGB565I
Still digital zoom	16X downscale from full input resolution and up to 4X upscale
Video/Viewfinder digital zoom	16X downscale from full input resolution and up to 4X upscale, with smooth zoom effect in x0.001 steps
Power supplies	2.8V or 1.8V +/- 5% (I/O ring) 1.8V +/- 5% (CCP interfaces and PLL) 1.2V +/- 5% (core logic), or 1.2V generated by the internal regulator from the 1.8V supply
Power requirements (typical)	3MP JPEG + QVGA RGB565 @ 20fps: – 165 mA @ 1.2V and 15 mA @ 1.8V for external 1.2V supply – 185mA @ 1.8V if using internal regulator Viewfinder QVGA RGB565 @ 20fps: – 45 mA @ 1.2V and 15 mA @ 1.8V for external 1.2V supply – 65mA @ 1.8V if using internal regulator Standby < 100µW
Package	Rohs compliant (Leadfree) – TFBGA 84 balls 6 x 6 x 1.2 mm, pin compatible with STV0984

Table 2. Temperature ranges

Storage	-40 to +150 °C
Operating	-25 to +70 °C

Figure 1. Application diagram

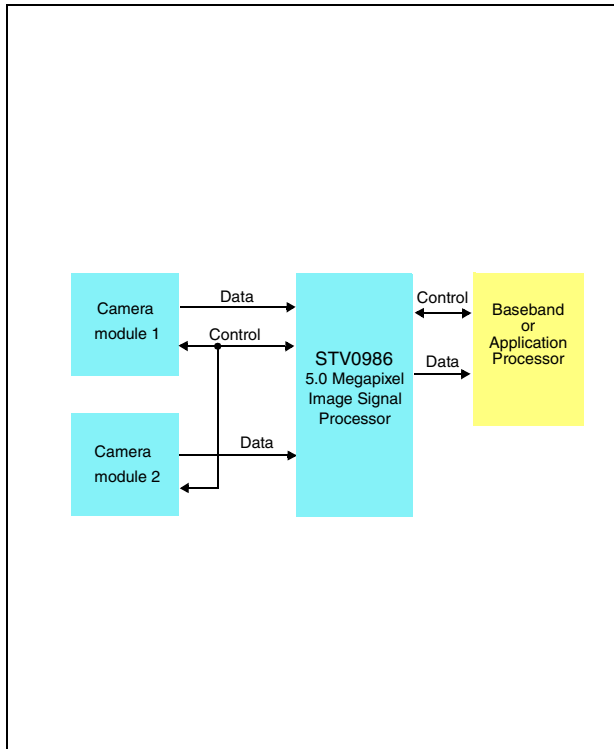
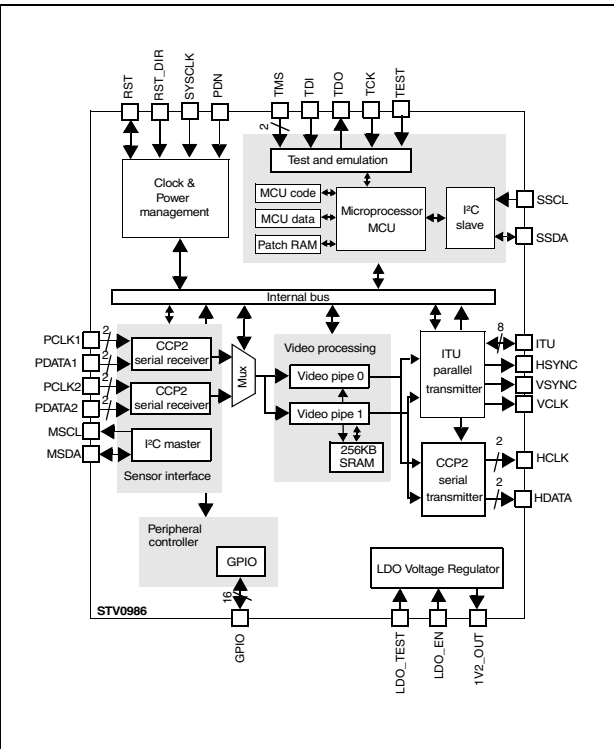

Figure 2. Block diagram



Ordering information

Table 3. Order codes

Part number	Description
STV0986/TR (Tape and Reel)	Rohs compliant (Leadfree) TFBGA 84 balls

Revision history

Table 4. Document revision history

Date	Revision	Changes
08-Jan-2007	1	Initial release.

Please Read Carefully:

Information in this document is provided solely in connection with ST products. STMicroelectronics NV and its subsidiaries ("ST") reserve the right to make changes, corrections, modifications or improvements, to this document, and the products and services described herein at any time, without notice.

All ST products are sold pursuant to ST's terms and conditions of sale.

Purchasers are solely responsible for the choice, selection and use of the ST products and services described herein, and ST assumes no liability whatsoever relating to the choice, selection or use of the ST products and services described herein.

No license, express or implied, by estoppel or otherwise, to any intellectual property rights is granted under this document. If any part of this document refers to any third party products or services it shall not be deemed a license grant by ST for the use of such third party products or services, or any intellectual property contained therein or considered as a warranty covering the use in any manner whatsoever of such third party products or services or any intellectual property contained therein.

UNLESS OTHERWISE SET FORTH IN ST'S TERMS AND CONDITIONS OF SALE ST DISCLAIMS ANY EXPRESS OR IMPLIED WARRANTY WITH RESPECT TO THE USE AND/OR SALE OF ST PRODUCTS INCLUDING WITHOUT LIMITATION IMPLIED WARRANTIES OF MERCHANTABILITY, FITNESS FOR A PARTICULAR PURPOSE (AND THEIR EQUIVALENTS UNDER THE LAWS OF ANY JURISDICTION), OR INFRINGEMENT OF ANY PATENT, COPYRIGHT OR OTHER INTELLECTUAL PROPERTY RIGHT.

UNLESS EXPRESSLY APPROVED IN WRITING BY AN AUTHORIZED ST REPRESENTATIVE, ST PRODUCTS ARE NOT RECOMMENDED, AUTHORIZED OR WARRANTED FOR USE IN MILITARY, AIR CRAFT, SPACE, LIFE SAVING, OR LIFE SUSTAINING APPLICATIONS, NOR IN PRODUCTS OR SYSTEMS WHERE FAILURE OR MALFUNCTION MAY RESULT IN PERSONAL INJURY, DEATH, OR SEVERE PROPERTY OR ENVIRONMENTAL DAMAGE. ST PRODUCTS WHICH ARE NOT SPECIFIED AS "AUTOMOTIVE GRADE" MAY ONLY BE USED IN AUTOMOTIVE APPLICATIONS AT USER'S OWN RISK.

Resale of ST products with provisions different from the statements and/or technical features set forth in this document shall immediately void any warranty granted by ST for the ST product or service described herein and shall not create or extend in any manner whatsoever, any liability of ST.

ST and the ST logo are trademarks or registered trademarks of ST in various countries.

Information in this document supersedes and replaces all information previously supplied.

The ST logo is a registered trademark of STMicroelectronics. All other names are the property of their respective owners.

© 2007 STMicroelectronics - All rights reserved

STMicroelectronics group of companies

Australia - Belgium - Brazil - Canada - China - Czech Republic - Finland - France - Germany - Hong Kong - India - Israel - Italy - Japan - Malaysia - Malta - Morocco - Singapore - Spain - Sweden - Switzerland - United Kingdom - United States of America

www.st.com