

**VOLTAGE RANGE: 150V**

**CURRENT: 30A**

### Features

- Ultra low vf
- High efficiency operation
- Low power loss
- Low stored charge majority carrier conduction
- High forward surge capability
- Lead free in compliance with EU RoHS 2011/65/EU directive

### Mechanical Data

- Circuit figure: Common cathode
- Leads: Solderable per mil-std-202, Method 208
- Polarity: as marked
- Mounting torque: 5 in-lbs maximum
- Terminals: Puretin plated
- Weight: TO-220AB 1.85 grams

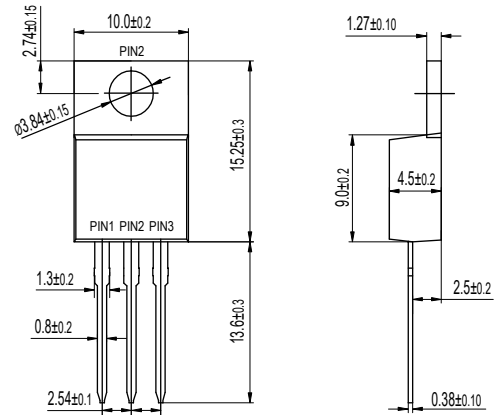
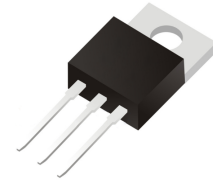

TO-220AB

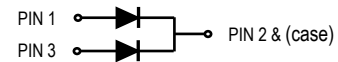

### Maximum Ratings $T_A = 25^\circ\text{C}$ unless otherwise specified

RATINGS	SYMBOL	STPS30150CT	UNIT
Maximum repetitive reverse voltage	VRRM	150	V
Maximum RMS voltage	VRMS	105	V
Maximum DC blocking voltage	VDC	150	V
Maximum average forward current per device per diode	I <sub>AV</sub>	30 15	A
Peak forward surge current, 8.3ms single half sine-wave superimposed on rated load	I <sub>FSM</sub>	300	A
Typical thermal resistance per diode (Note 1)	R <sub>θ-JC</sub>	4.5	°C/W
Operating junction temperature range	T <sub>J</sub>	-55 to +150	°C
Storage temperature range	T <sub>STG</sub>	-55 to +150	°C

Notes: 1. Thermal resistance from junction to case.



## Electrical Characteristics T<sub>A</sub> = 25°C unless otherwise specified

PARAMETER	SYMBOL	TEST CONDITIONS	MIN.	TYP.	MAX.	UNIT
Breakdown voltage per diode	V <sub>BR</sub>	I <sub>R</sub> =0.5mA	150	-	-	V
Instantaneous forward voltage per diode	V <sub>F</sub>	I <sub>F</sub> =15A      T <sub>J</sub> =25°C	-	0.85	0.89	V
		I <sub>F</sub> =15A      T <sub>J</sub> =125°C	-	-	0.76	V
Reverse current per diode	I <sub>R</sub>	V <sub>R</sub> =150V      T <sub>J</sub> =25°C	-	-	50	μA
		V <sub>R</sub> =150V      T <sub>J</sub> =125°C	-	-	25	mA

FIG. 1 - TYPICAL FORWARD CURRENT DERATING CURVE

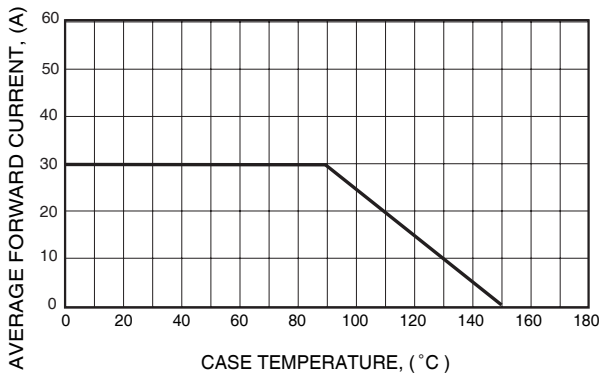

FIG. 2 - MAXIMUM NON-REPETITIVE FORWARD SURGE CURRENT

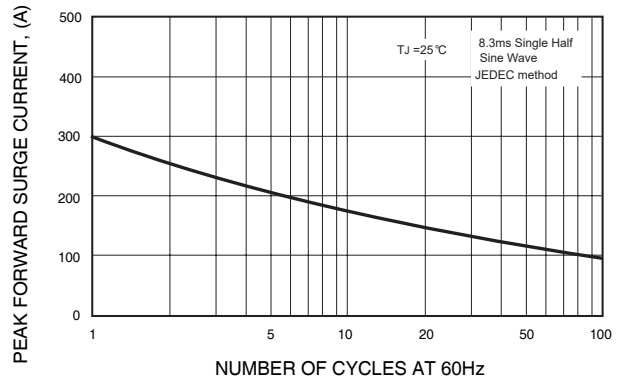

FIG. 3 - TYPICAL REVERSE CHARACTERISTICS

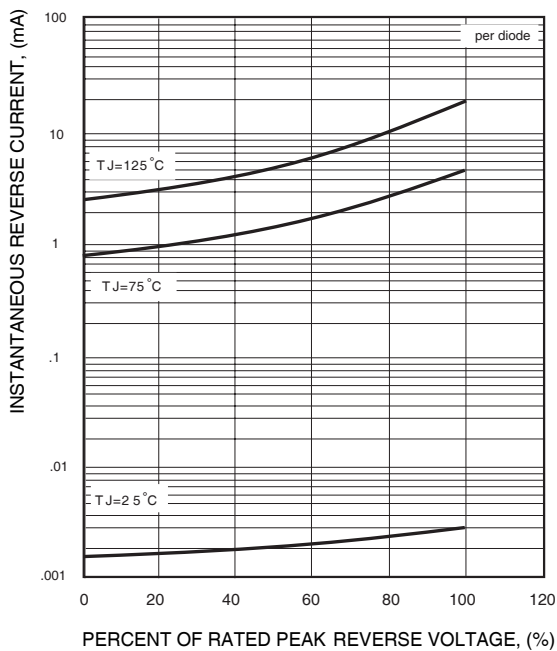

FIG. 4 - TYPICAL INSTANTANEOUS FORWARD CHARACTERISTICS

