



STMPE1801

Xpander Logic™

18-bit enhanced port expander with keypad controller

Features

- 18 GPIOs configurable as GPI, GPO, keypad matrix, special key or dedicated key function
- Operating voltage: 1.65 - 3.6 V
- Hardware keypad controller (KPC) (10 x 8 matrix with 4 optional dedicated keys maximum)
- Keypad controller capable of detecting keypress in hibernation mode
- Interrupt output (open drain) pin
- Advanced power management system
- Ultra-low standby mode current
- Programmable pull-up resistors for all GPIO pins
- ESD performance on GPIO pins:
 - ± 8 kV human body model (JESD22 A114-C)
- ESD performance on V_{CC}, GND, INT_B, R_{STB}, SCL, SDA pins:
 - ± 3 kV human body model (JESD22 A114-C)



Description

The STMPE1801 is a GPIO (general purpose input/output) port expander capable of interfacing a main digital ASIC via the two-line bidirectional bus (I²C). A separate GPIO expander IC is often used in mobile multimedia platforms to resolve the problem of the limited number of GPIOs typically available on digital engines. The STMPE1801 offers high flexibility, as each I/O can be configured as input, output, special key, keypad matrix or dedicated key function. This device is designed to include very low quiescent current, and a wakeup feature for each I/O, to optimize the power consumption of the device. Potential applications for the STMPE1801 include portable media players, game consoles, mobile and smart phones.

Table 1. Device summary

Order code	Package	Packaging
STMPE1801BJR	Flip-chip CSP 25 (2.03 x 2.03 mm) 0.4 mm pitch	Tape and reel

Contents

- 1 Block diagram 4**
- 2 Pin settings 5**
 - 2.1 Pin connection 5
 - 2.2 Pin description 5
 - 2.3 GPIO pin functions 6
- 3 Maximum ratings 8**
 - 3.1 Absolute maximum ratings 8
 - 3.2 Thermal data 8
- 4 Electrical specification 9**
 - 4.1 DC electrical characteristics 9
 - 4.2 Input/Output DC electrical characteristics 10
- 5 Register address 11**
- 6 I2C specification 14**
 - 6.1 I2C related pins 14
 - 6.2 I2C addressing 14
 - 6.3 Start condition 14
 - 6.4 Stop condition 14
 - 6.5 Acknowledge bit (ACK) 15
 - 6.6 Data input 15
 - 6.7 Memory addressing 15
 - 6.8 Operation modes 15
 - 6.9 General call address 17
- 7 System controller 18**
 - 7.1 System level registers 18
 - 7.2 States of operation 20
 - 7.2.1 Auto-hibernate 20
 - 7.2.2 Keypress detect in the Hibernate mode 21

8 **Clocking system 22**

 8.0.1 Clock source 22

 8.0.2 Power mode programming sequence 23

9 **Interrupt system 24**

 9.1 Interrupt system register map 25

 9.2 Interrupt latency for the GPIO hot keys 25

 9.3 Programming sequence 31

10 **GPIO controller 32**

 10.1 GPIO control registers 33

 10.1.1 Bit description 33

 10.2 Hotkey feature 34

 10.2.1 Programming sequence for Hotkey 34

 10.2.2 Minimum pulse width 34

11 **Keypad controller 35**

 11.1 Keypad configurations 38

 11.2 Keypad controller registers 40

 11.3 Data registers 46

 11.4 Keypad combination key registers 50

 11.5 Using the keypad controller 51

 11.5.1 Ghost key handling 51

 11.5.2 Key detection priority 51

 11.5.3 Keypad wakeup from Hibernate mode 52

 11.5.4 Keypad controller combination key interrupt 52

12 **Miscellaneous features 53**

 12.1 Reset 53

13 **Package mechanical data 54**

14 **Revision history 59**

1 Block diagram

Figure 1. STMPE1801 block diagram

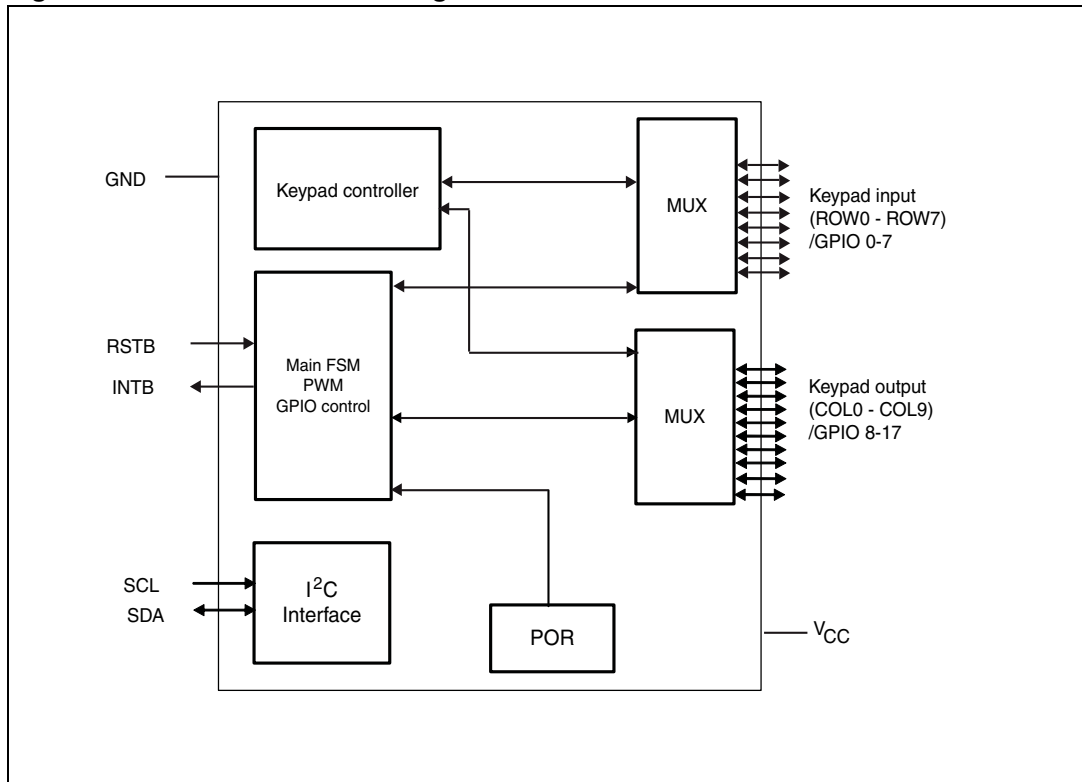

2 Pin settings

2.1 Pin connection

Figure 2. Pin connection (top-through view)

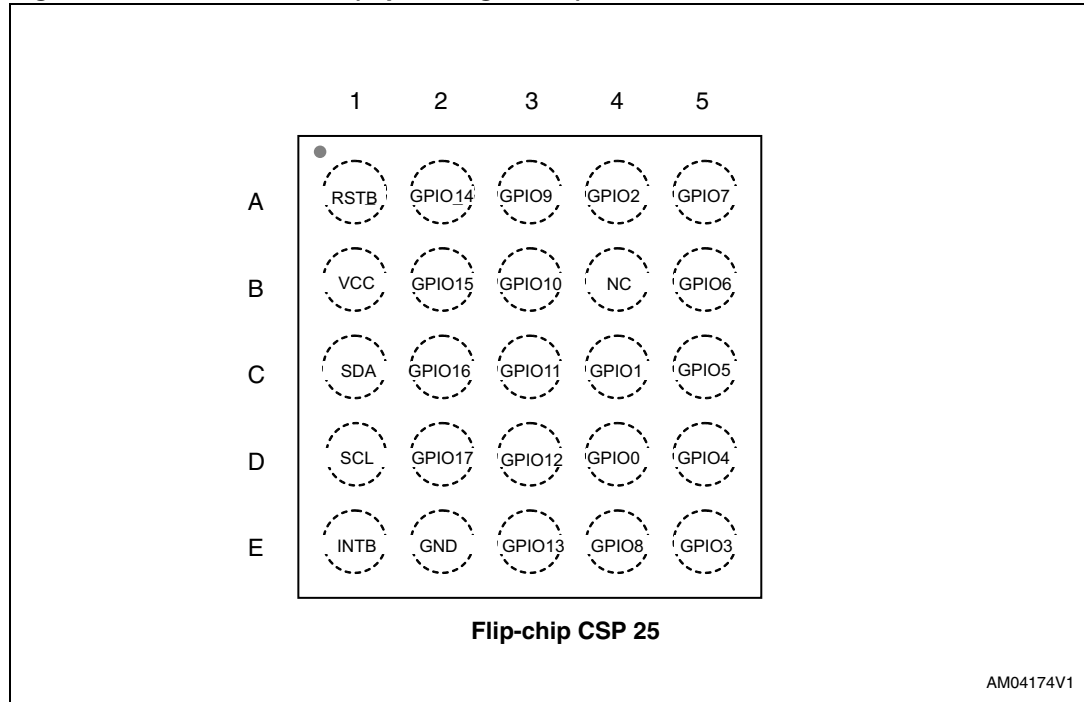

2.2 Pin description

Table 2. Pin description

Pin number	Type	Symbol	Name and function
D4	I/O	GPIO0	GPIO0/ROW0
C4	I/O	GPIO1	GPIO1/ROW1
A4	I/O	GPIO2	GPIO2/ROW2
E5	I/O	GPIO3	GPIO3/ROW3
D5	I/O	GPIO4	GPIO4/ROW4
C5	I/O	GPIO5	GPIO5/ROW5
B5	I/O	GPIO6	GPIO6/ROW6
A5	I/O	GPIO7	GPIO7/ROW7
E4	I/O	GPIO8	GPIO8/COL0
A3	I/O	GPIO9	GPIO9/COL1
B3	I/O	GPIO10	GPIO10/COL2

Table 2. Pin description (continued)

Pin number	Type	Symbol	Name and function
C3	I/O	GPIO11	GPIO11/COL3
D3	I/O	GPIO12	GPIO12/COL4
E3	I/O	GPIO13	GPIO13/COL5
A2	I/O	GPIO14	GPIO14/COL6
B2	I/O	GPIO15	GPIO15/COL7
C2	I/O	GPIO16	GPIO16/COL8
D2	I/O	GPIO17	GPIO17/COL9
E1	O	INTB	Open drain interrupt output pin. Programmable active low (a pull-up resistor is required) or active high (a pull-down resistor is required). Fail safe. Pull to V _{CC} if not in use.
A1	I	RSTB	External reset input. Active low. Fail safe. Reset pulse width must be more than 500 μs to be valid.
C1	A	SDA	I ² C data. Fail safe
D1	A	SCL	I ² C clock. Fail safe
B4	-	NC	No connect
B1	-	V _{CC}	Power supply
E2	-	GND	Ground

2.3 GPIO pin functions

Table 3. GPIO pin function

Name	Primary function	Alternate function
GPIO0	GPIO	Keypad row 0
GPIO1	GPIO	Keypad row 1
GPIO2	GPIO	Keypad row 2
GPIO3	GPIO	Keypad row 3
GPIO4	GPIO	Keypad row 4
GPIO5	GPIO	Keypad row 5
GPIO6	GPIO	Keypad row 6
GPIO7	GPIO	Keypad row 7
GPIO8	GPIO	Keypad column 0
GPIO9	GPIO	Keypad column 1
GPIO10	GPIO	Keypad column 2
GPIO11	GPIO	Keypad column 3
GPIO12	GPIO	Keypad column 4

Table 3. GPIO pin function

Name	Primary function	Alternate function
GPIO13	GPIO	Keypad column 5
GPIO14	GPIO	Keypad column 6
GPIO15	GPIO	Keypad column 7
GPIO16	GPIO	Keypad column 8
GPIO17	GPIO	Keypad column 9

The default function is always GPIO. As soon as the key scanning is enabled through the keypad registers, the function is then switched to the key function and then any configuration made in the GPIO registers is ignored.

3 Maximum ratings

Stressing the device above the rating listed in the “absolute maximum ratings” table may cause permanent damage to the device. These are stress ratings only and operation of the device at these or any other conditions above those indicated in the operating sections of this specification is not implied. Exposure to absolute maximum rating conditions for extended periods may affect device reliability.

3.1 Absolute maximum ratings

Table 4. Absolute maximum ratings

Symbol	Parameter	Value	Unit
V_{CC}	Supply voltage	4.5	V
V_{IN}	Input voltage on GPIO pin	4.5	V
V_{ESD}	Minimum ESD protection on each GPIO pin (HBM model - JESD22 A114-C)	±8	kV
V_{ESD}	ESD protection on other pins (HBM model - JESD22 A114-C)	±3	kV

3.2 Thermal data

Table 5. Thermal data

Symbol	Parameter	Min	Typ	Max	Unit
R_{thJA}	Thermal resistance junction-ambient	–	100	–	°C/W
T_A	Operating ambient temperature	-40	25	85	°C
T_J	Operating junction temperature	-40	25	125	°C

4 Electrical specification

4.1 DC electrical characteristics

Table 6. DC electrical characteristics

Symbol	Parameter	Test conditions		Value			Unit
				Min	Typ	Max	
V_{CC}	Supply voltage	-		1.65	-	3.6	V
I_{CC}	Active current (core and analog) - 1 key press	1.8 V		-	28	55	μ A
		3.3 V		-	90	140	μ A
$I_{HIBERNATE}$	Hibernate current	1.8 V	25 °C	-	-	0.5	μ A
			85 °C	-	-	1	
		3.3 V	25 °C	-	-	0.5	μ A
			85 °C	-	-	1	
I_{NTB}	Open drain output current	$V_{OL(max)}=0.45$ V at $V_{CC}=1.8$ V $V_{OL(max)}=0.83$ V at $V_{CC}=3.3$ V		-	4	-	mA

4.2 Input/Output DC electrical characteristics

Table 7. I/O DC electrical characteristics

Symbol	Parameter	Test conditions	Value			Unit
			Min	Typ	Max	
V _{IL}	Low level input voltage	V _{CC} = 1.8 V	–	–	0.2 V _{CC}	V
		V _{CC} = 3.3 V	–	–	0.2 V _{CC}	
V _{IH}	High level input voltage	V _{CC} = 1.8 V	0.8 V _{CC}	–	–	V
		V _{CC} = 3.3 V	0.8 V _{CC}	–	–	
V _{HYST}	Schmitt trigger hysteresis	V _{CC} = 1.8 V	–	0.10	–	V
		V _{CC} = 3.3 V	–	0.20	–	
V _{OL}	Low level output voltage	I _{OL} = 4 mA, V _{CC} = 1.8 V	–	–	0.45	V
		I _{OL} = 4 mA, V _{CC} = 3.3 V	–	–	0.45	
V _{OH}	High level output voltage	I _{OH} = -4 mA, V _{CC} = 1.8 V	1.35	–	–	V
		I _{OH} = -4 mA, V _{CC} = 3.3 V	2.48	–	–	
R _{UP}	Equivalent pull-up resistance	V _{CC} = 3.3 V. Active implementation, R value is determined by the current measured at 0 V	30	60	90	kΩ
		V _{CC} = 1.8 V. Active implementation, R value is determined by the current measured at 0 V	50	100	150	

5 Register address

Table 8. STMPE1801 register summary table

Address	Register name	Description	Auto-increment	7	6	5	4	3	2	1	0
00	CHIP_ID	Chip identification	No	8-bit CHIP ID							
01	VERSION_ID	Version identification	No	8-bit VERSION ID							
02	SYS_CTRL	System control	No	SF_RST	RESERVED				GPI_DB1	GPI_DB0	RSVD
04	INT_CTRL_LOW	Interrupt control	Yes	RESERVED				IC2	IC1	IC0	
05	INT_CTRL_HIGH			RESERVED							
06	INT_EN_MASK_LOW	Interrupt enable mask	Yes	RESERVED		IE4	IE3	IE2	IE1	IE0	
07	INT_EN_MASK_HIGH			RESERVED							
08	INT_STA_LOW	Interrupt status	Yes	RESERVED		IE4	IE3	IE2	IE1	IE0	
09	INT_STA_HIGH			RESERVED							
0A	INT_EN_GPIO_MASK_LOW	Interrupt enable GPIO mask	Yes	IEG7	IEG6	IEG5	IEG4	IEG3	IEG2	IEG1	IEG0
0B	INT_EN_GPIO_MASK_MID			IEG15	IEG14	IEG13	IEG12	IEG11	IEG10	IEG9	IEG8
0C	INT_EN_GPIO_MASK_HIGH			RESERVED						IEG17	IEG16
0D	INT_STA_GPIO_LOW	Interrupt status GPIO	Yes	ISG7	ISG6	ISG5	ISG4	ISG3	ISG2	ISG1	ISG0
0E	INT_STA_GPIO_MID			ISG15	ISG14	ISG13	ISG12	ISG11	ISG10	ISG9	ISG8
0F	INT_STA_GPIO_HIGH			RESERVED						ISG17	ISG16
10	GPIO_SET_LOW	GPIO set pin state	Yes	IO7	IO6	IO5	IO4	IO3	IO2	IO1	IO0
11	GPIO_SET_MID			IO15	IO14	IO13	IO12	IO11	IO10	IO9	IO8
12	GPIO_SET_HIGH			RESERVED						IO17	IO16
13	GPIO_CLR_LOW	GPIO clear pin state	Yes	IO7	IO6	IO5	IO4	IO3	IO2	IO1	IO0
14	GPIO_CLR_MID			IO15	IO14	IO13	IO12	IO11	IO10	IO9	IO8
15	GPIO_CLR_HIGH			RESERVED						IO17	IO16
16	GPIO_MP_LOW	GPIO monitor pin state	Yes	IO7	IO6	IO5	IO4	IO3	IO2	IO1	IO0
17	GPIO_MP_MID			IO15	IO14	IO13	IO12	IO11	IO10	IO9	IO8
18	GPIO_MP_HIGH			RESERVED						IO17	IO16

Table 8. STMPE1801 register summary table

Address	Register name	Description	Auto-increment	7	6	5	4	3	2	1	0	
19	GPIO_SET_DIR_LOW	GPIO set pin direction register	Yes	IO7	IO6	IO5	IO4	IO3	IO2	IO1	IO0	
1A	GPIO_SET_DIR_MID			IO15	IO14	IO13	IO12	IO11	IO10	IO9	IO8	
1B	GPIO_SET_DIR_HIGH			RESERVED							IO17	IO16
1C	GPIO_RE_LOW	GPIO rising edge	Yes	IO7	IO6	IO5	IO4	IO3	IO2	IO1	IO0	
1D	GPIO_RE_MID			IO15	IO14	IO13	IO12	IO11	IO10	IO9	IO8	
1E	GPIO_RE_HIGH			RESERVED							IO17	IO16
1F	GPIO_FE_LOW	GPIO falling edge	Yes	IO7	IO6	IO5	IO4	IO3	IO2	IO1	IO0	
20	GPIO_FE_MID			IO15	IO14	IO13	IO12	IO11	IO10	IO9	IO8	
21	GPIO_FE_HIGH			RESERVED							IO17	IO16
22	GPIO_PULL_UP_LOW	GPIO pull up	Yes	IO7	IO6	IO5	IO4	IO3	IO2	IO1	IO0	
23	GPIO_PULL_UP_MID			IO15	IO14	IO13	IO12	IO11	IO10	IO9	IO8	
24	GPIO_PULL_UP_HIGH			RESERVED							IO17	IO16
30	KPC_ROW	Keypad row scanning	Yes	ROW7	ROW6	ROW5	ROW4	ROW3	ROW2	ROW1	ROW0	
31	KPC_COL_LOW	Keypad column scanning	Yes	COL7	COL6	COL5	COL4	COL3	COL2	COL1	COL0	
32	KPC_COL_HIGH			RESERVED							COL9	COL8
33	KPC_CTRL_LOW	Key config: Scan count and dedicated key	Yes	SCAN_COUNT 0-3				DKEY 0-3				
34	KPC_CTRL_MID			DB6	DB5	DB4	DB3	DB2	DB1	DB0	Rsvd	
35	KPC_CTRL_HIGH			Rsvd	CM B_KEY	RESERVED					SCAN_FREQ	
36	KPC_CMD	Keypad command	Yes	RESERVED							KPC_LCK	SCAN
37	KPC_COMB_KEY_0	Keypad combination key mask	Yes	C4	C3	C2	C1	C0	R2	R1	R0	
38	KPC_COMB_KEY_1			C4	C3	C2	C1	C0	R2	R1	R0	
39	KPC_COMB_KEY_2			C4	C3	C2	C1	C0	R2	R1	R0	

Table 8. STMPE1801 register summary table

Addresses	Register name	Description	Auto-increment	7	6	5	4	3	2	1	0
3A	KPC_DATA_BYTE0	Keypad data	Yes	UP/DW N	C3	C2	C1	C0	R2	R1	R0
3B	KPC_DATA_BYTE1			UP/DW N	C3	C2	C1	C0	R2	R1	R0
3C	KPC_DATA_BYTE2			UP/DW N	C3	C2	C1	C0	R2	R1	R0
3D	KPC_DATA_BYTE3			SF7	SF6	SF5	SF4	SF3	SF2	SF1	SF0
3E	KPC_DATA_BYTE4			RESERVED			Dedicated Key 0 - 3				

6 I²C specification

The features supported by the I²C interface are listed below:

- I²C slave device
- Operates at V_{CC} (1.8 - 3.6 V)
- Compliant to Philips I²C specification version 2.1
- Supports standard (up to 100 kbps) and fast (up to 400 kbps) modes
- 7-bit device addressing modes
- General call
- Start/Restart/Stop

6.1 I²C related pins

- SCL
- SDA

The device supports both 1.8 V I²C and 3.3 V I²C operations. It is recommended that V_{pullup} at SCL and SDA externally is greater or equal to V_{CC}.

6.2 I²C addressing

The STMPE1801 7-bit addressing is set to 40h.

6.3 Start condition

A Start condition is identified by a falling edge of SDA while SCL is stable at high state. A Start condition must precede any data/command transfer. The device continuously monitors for a Start condition and does not respond to any transaction unless one is encountered.

The first byte is scanned after the START command is detected to check for device ID. Ensure that all state machines are flushed when START instruction is issued.

6.4 Stop condition

A Stop condition is identified by a rising edge of SDA while SCL is stable at high state. A Stop condition terminates the communication between the slave device and bus master. A read command that is followed by NoAck can be followed by a Stop condition to force the slave device into idle mode. When the slave device is in idle mode, it is ready to receive the next I²C transaction. A Stop condition at the end of a write command stops the write operation to the registers.

Once the Stop condition is detected, the device should release the bus and go to Hibernate mode if there is no more activity.

An I²C transaction with a START bit followed immediately by a STOP condition should not cause any I²C lock-up.

6.5 Acknowledge bit (ACK)

The acknowledge bit is used to indicate a successful byte transfer. The bus transmitter releases the SDA after sending eight bits of data. During the ninth bit, the receiver pulls the SDA low to acknowledge the receipt of the eight bits of data. The receiver may leave the SDA in high state if it does not acknowledge the receipt of the data.

6.6 Data input

The device samples the data input on SDA on the rising edge of the SCL. The SDA signal must be stable during the rising edge of SCL and the SDA signal must change only when SCL is driven low.

6.7 Memory addressing

For the bus master to communicate to the slave device, the bus master must initiate a Start condition and be followed by the slave device address. Accompanying the slave device address, there is a Read/Write bit (R/\overline{W}). The bit is set to 1 for Read and 0 for Write operation.

If a match occurs on the slave device address, the corresponding device gives an acknowledgement on the SDA during the 9th bit time. If there is no match, it deselects itself from the bus by not responding to the transaction.

6.8 Operation modes

Table 9. Operating modes

Mode	Byte	Programming sequence
Read	≥1	START, Device address, R/\overline{W} =0, Register Address to be read
		RESTART, Device Address, R/\overline{W} =1, Data Read, STOP
		If no STOP is issued, the Data Read can be continuously performed. If the register address falls within the range that allows address auto-increment, then register address auto-increments internally after every byte of data being read. For register address that falls within a non-incremental address range, the address is kept static throughout the entire read operation. Refer to Table 8.: STMPE1801 register summary table for the address ranges that are auto-increment and non-increment. An example of such a non-increment address is FIFO.

Table 9. Operating modes

Mode	Byte	Programming sequence
Write	≥1	START, Device Address, R/W =0, Register Address to be written, Data Write, STOP
		If no STOP is issued, the Data Write can be continuously performed. If the register address falls within the range that allows address auto-increment, then register address auto-increment internally after every byte of data being written. For those register addresses that fall within a non-incremental address range, the address will be kept static throughout the entire write operation. Refer to Table 8: STMPE1801 register summary table for the address ranges that are auto-increment and non-increment. An example of a non-increment address is Data Port for initializing the PWM.

Figure 3. Operating modes

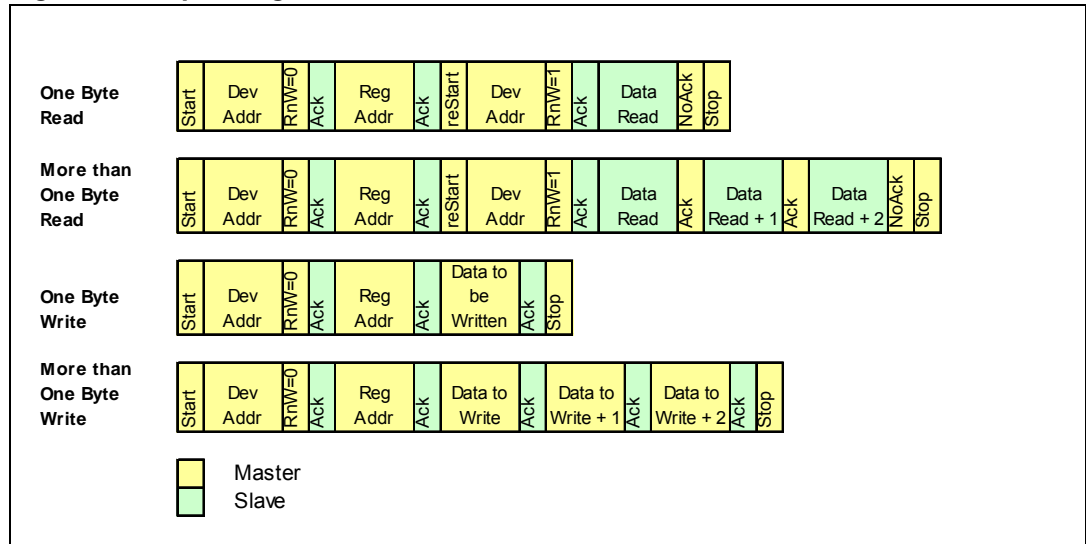

6.9 General call address

A general call address is a transaction with the slave address of 0x00 and $R/\overline{W}=0$. When a general call address is asserted, the STMPE1801 responds to this transaction with an acknowledgement and behaves as a slave-receiver mode. The meaning of a general call address is defined in the second byte sent by the master-transmitter.

Table 10. General call address

R/\overline{W}	Second byte value	Definition
0	0x06	A 2-byte transaction in which the second byte tells the slave device to reset and write (or latch in) the 2-bit programmable part of the slave address.
0	0x00	Not allowed as second byte.

Note: All other second byte values are ignored.

7 System controller

7.1 System level registers

The system controller is the heart of the STMPE1801. It contains the registers for power control and chip identification.

The system registers are:

Address	Register name
00	CHIP_ID
01	VERSION_ID
02	SYS_CTRL

CHIP_ID

Chip identification register

7	6	5	4	3	2	1	0
8-bit CHIP_ID							
R	R	R	R	R	R	R	R
1	1	0	0	0	0	0	1

VERSION_ID

Version identification register

7	6	5	4	3	2	1	0
8-bit VERSION_ID							
R	R	R	R	R	R	R	R
0	0	0	1	0	0	0	0

SYS_CTRL

System control register

7	6	5	4	3	2	1	0
SF_RST	RESERVED				GPI_DB1	GPI_DB0	RSVD
W	R	R	R	R	RW	RW	R
0	0	0	0	0	1	1	0

Address: 02

Type: R/W

Reset: 0x06

Description: System control register.

[7] SF_RST: Soft Reset

Writing a '1' to this bit will do a soft reset of the device. Once the reset is done, this bit is cleared to '0' by the HW.

[6:3] RESERVED

[2:1] GPI_DB [1:0]

GPI [17:0] operational mode de-bounce time

'00' = 30 μs

'01' = 90 μs

'10' = 150 μs

'11' = 210 μs (default)

[0] RESERVED

7.2 States of operation

Figure 4. States of operation

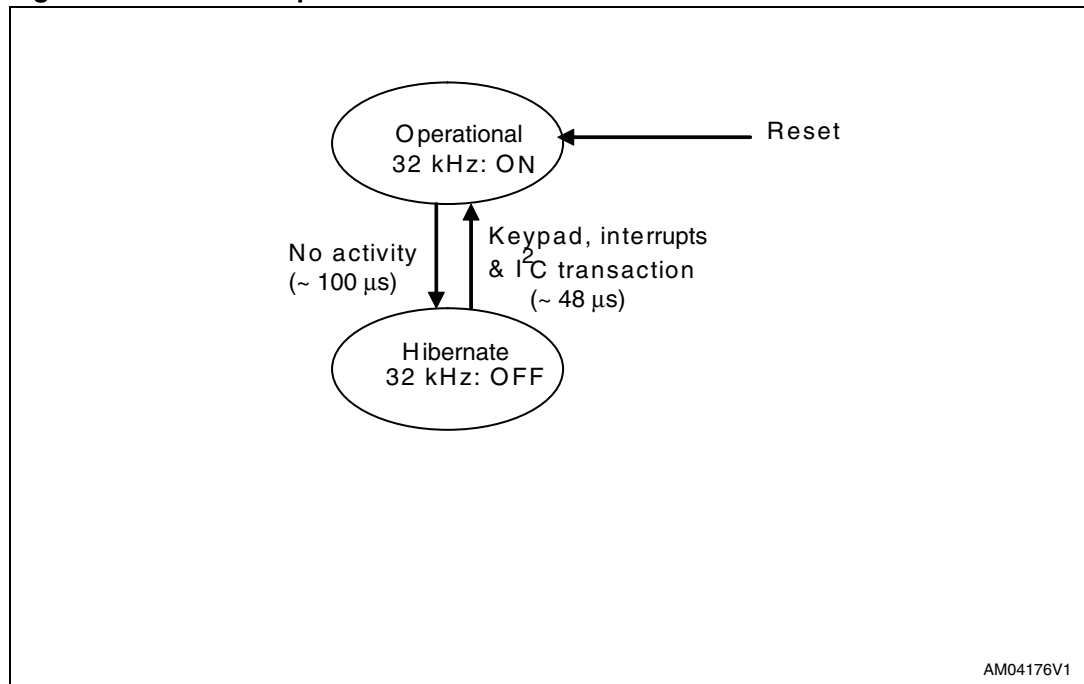

The device has two main modes of operation:

- **Operational mode:** This is the mode, whereby normal operation of the device takes place. In this mode, the main finite state machine (FSM) unit routes 32 kHz clock to all the device blocks.
- **Hibernate mode:** This mode is entered automatically in auto-hibernate mode. When the device is in Hibernate mode, the 32 kHz clock is disabled. If there is a keypad activity, interrupt event, hotkey activity or I²C transaction, the device switches to operational mode. A reset event brings back the system to operational mode.

7.2.1 Auto-hibernate

The STMPE1801 is set to go into Hibernate mode automatically if there is a period of inactivity (~ 100 μs) following the completion of I²C transaction with the host. The STMPE1801 will continue counting down for hibernation mode activation even if there is an I²C transaction sent by the host to other slave devices. Any I²C transaction from the host to the STMPE1801 resets the hibernate counter.

Auto-hibernate mode occurs only when all the keys are released and FIFO is emptied through reading. This is to prevent any loss of data.

The hibernate mode counter should start when any of the following conditions is detected:

- Once the I²C transaction is completed or a STOP condition is detected.
- If the device ID in the I²C transaction is invalid.

When there is a keypad activity, the device should go into Hibernate mode **ONLY** when all the previously pressed keys are released.

Any keypad activity, interrupt event, hotkey activity or VALID I²C transaction wakes up the device from Hibernate mode and switches to operational mode automatically.

7.2.2 Keypress detect in the Hibernate mode

When in Hibernate mode, any keypress detected causes the system to go into operational mode (~48 μs). The system will then de-bounce the key to detect a valid key. If the keypress detected is valid, the system stays in operation mode. If the key detected is invalid, the system goes back into Hibernate mode.

8 Clocking system

In order to reduce the power consumption, the STMPE1801 turns off the oscillator during Hibernate mode.

Figure 5. Clocking system

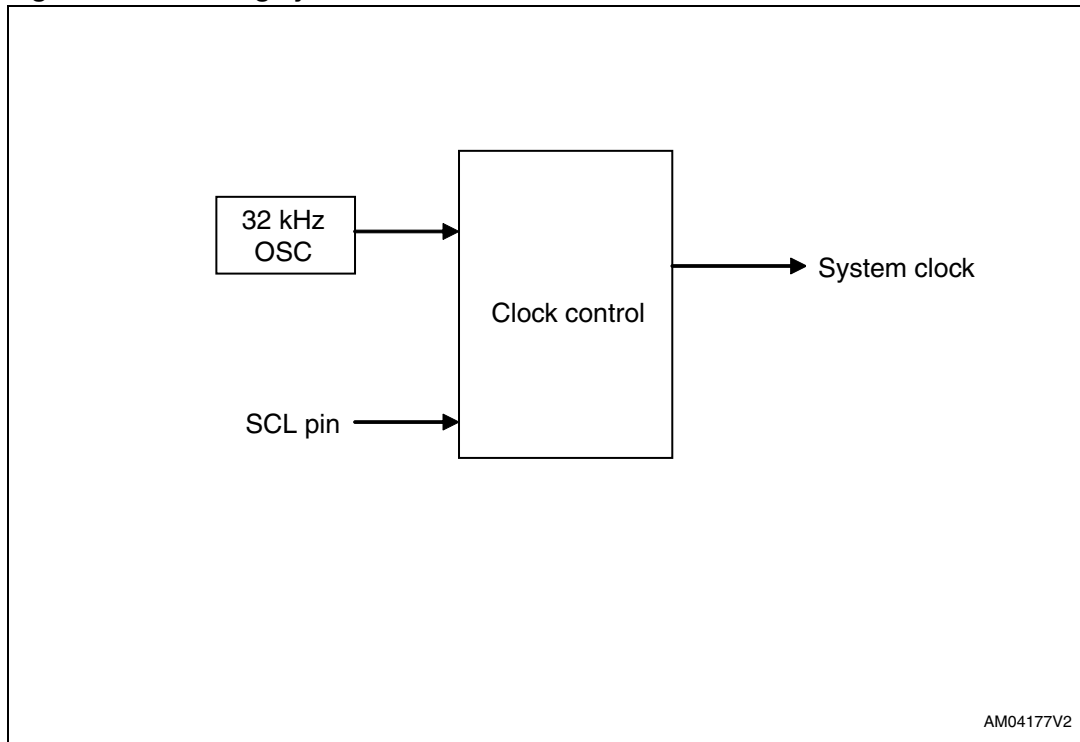

8.0.1 Clock source

By default, when the STMPE1801 powers up, it derives a 32 kHz clock from the internal RC oscillator for its operation.

There are 4 sources of reset:

- RSTB pin
- Low voltage detect (LVD) reset
- Soft reset bit of the SYS_CTRL register
- I²C reset from the I²C block.

8.0.2 Power mode programming sequence

The device enters auto Hibernate mode when there is inactivity for a fixed period of time.

To wake up the device, the host is required to:

- Send an I²C transaction to the device.

To do a soft reset to the device, the host needs to do the following:

- Write a '1' to bit 7 of the SYS_CTRL register. This bit is automatically cleared upon reset.

To come out of the Hibernate mode, the following needs to be done by the host:

- Assert a system reset
- Or put a wakeup on the I²C transaction
- Interrupt activity

9 Interrupt system

The STMPE1801 uses a highly flexible interrupt system. It allows the host system to configure the type of system events that should result in an interrupt, and pinpoints the source of interrupt by status registers. The INT pin can be configured as active high (a pull-down resistor is required), or active low (a pull-up resistor is required). If INT pin is not in use, it is necessary to pull INT pin to V_{CC} .

Once asserted, the INT pin would de-assert when a read is done to the corresponding bit either in the INT_STA register or INT_STA_GPIO register.

Figure 6. Interrupt system

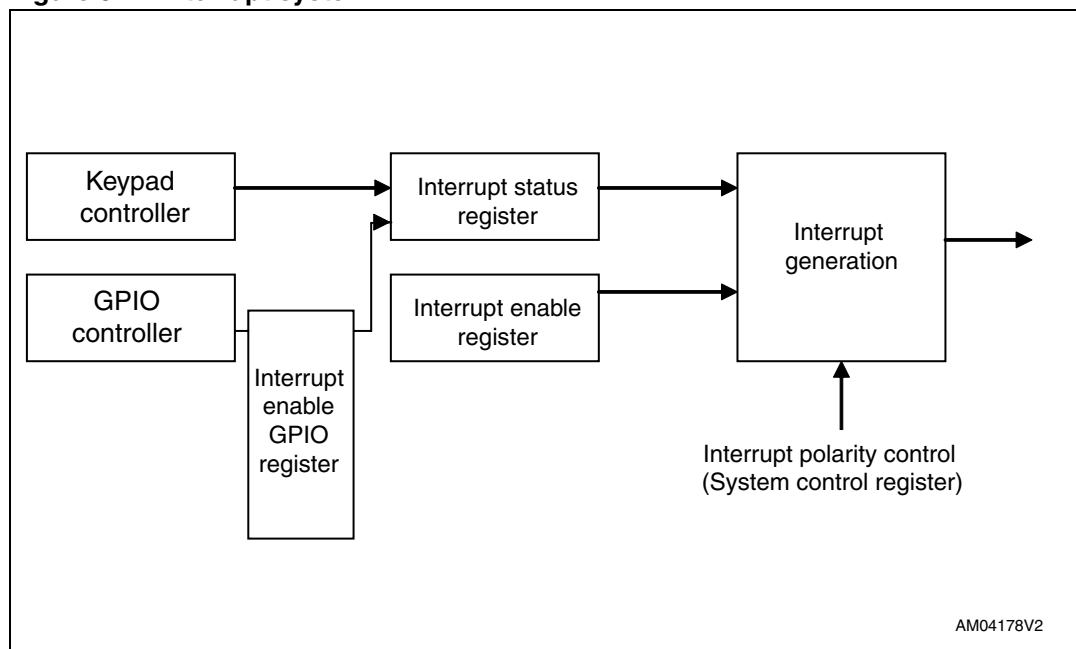

9.1 Interrupt system register map

Table 11. Interrupt system register map

Address	Register name	Description	Auto-increment (during sequential R/W)
04	INT_CTRL_LOW	Interrupt control register	Yes
05	INT_CTRL_HIGH		Yes
06	INT_EN_MASK_LOW	Interrupt enable mask register	Yes
07	INT_EN_MASK_HIGH		Yes
08	INT_STA_LOW	Interrupt status register	Yes
09	INT_STA_HIGH		Yes
0A	INT_EN_GPIO_MASK_LOW	Interrupt enable GPIO mask register	Yes
0B	INT_EN_GPIO_MASK_MID		Yes
0C	INT_EN_GPIO_MASK_HIGH		Yes
0D	INT_STA_GPIO_LOW	Interrupt status GPIO register	Yes
0E	INT_STA_GPIO_MID		Yes
0F	INT_STA_GPIO_HIGH		Yes

9.2 Interrupt latency for the GPIO hot keys

When the generation of interrupts by the GPIO as input is enabled for the hot keys, the latency (time taken from actual transition at GPIO to time of INT pin assertion) is shown in the following table:

Table 12. GPIO hot keys interrupt latency

State of operation	Interrupt latency	Comments
Hibernation	>200 μs (default)	Latency can be programmed by the GPI_DB bits of SYS_CTRL register
Active	>200 μs (default)	

INT_CTRL

Interrupt control register

15	14	13	12	11	10	9	8	7	6	5	4	3	2	1	0
INT_CTRL_HIGH								INT_CTRL_LOW							
Reserved												IC2	IC1	IC0	
R	R	R	R	R	R	R	R	R	R	R	R	R	RW	RW	RW

Address: 04, 05

Type: R, R/W

Reset: 0x00

Description: The interrupt control register is used to configure the interrupt controller. It has global enable interrupt mask bit that controls the interruption to the host.

[15:3] RESERVED

[2] IC2: Output Interrupt polarity

'0' = Active low/falling edge

'1' = Active high/rising edge

[1] IC1: Output Interrupt type

'0' = Level interrupt

'1' = Edge interrupt (Pulse width of 200µs)

[0] IC0: Global interrupt mask bit

When this bit is written a '1', it allows interruption to the host. If it is written with a '0', then, it disables all interruption to the host. Writing to this bit does not affect the INT_EN_MASK value.

INT_EN_MASK

Interrupt enable mask register

15	14	13	12	11	10	9	8	7	6	5	4	3	2	1	0
INT_EN_MASK_HIGH								INT_EN_MASK_LOW							
RESERVED											IE4	IE3	IE2	IE1	IE0
R	R	R	R	R	R	R	R	R	R	R	RW	RW	RW	RW	RW
0	0	0	0	0	0	0	0	0	0	0	0	0	0	0	0

Address: 06, 07

Type: R, R/W

Reset: 0x00

Description: The interrupt enable mask register is used to enable the interruption from a particular interrupt source to the host.

[15:4] RESERVED

[4:0] IE[x]:

Interrupt Enable Mask (where x = 3 to 0)

IE0: Default value is 0.

IE1: Keypad controller interrupt mask

IE2: Keypad controller FIFO overflow interrupt mask

IE3: GPIO controller interrupt mask

IE4: Combination key interrupt enable

Writing a '1' to the IE[x] bit enables the interruption to the host.

INT_STA

Interrupt status register

15	14	13	12	11	10	9	8	7	6	5	4	3	2	1	0
INT_STA_HIGH								INT_STA_LOW							
RESERVED											IS4	IS3	IS2	IS1	IS0
R	R	R	R	R	R	R	R	R	R	R	R	R	R	R	R
0	0	0	0	0	0	0	0	0	0	0	0	0	0	0	1

Address: 08, 09

Type: R

Reset: 0x00

Description: The interrupt status register monitors the status of the interruption from a particular interrupt source to the host. The INT_STA bits are constantly updated regardless whether the INT_EN bits are enabled or not.

[15:4] RESERVED

[4:0] IS[x]

Interrupt status (where x = 3 to 0)

Read:

IS0: Wake-up interrupt status

IS1: Keypad controller interrupt status

IS2: Keypad controller FIFO overflow interrupt status

IS3: GPIO controller interrupt status

IS4: Combination key interrupt status

Reading the INT_STA register clears all interrupt status bits to '0' which had been set to '1' prior to the read event.

INT_EN_GPIO_MASK

Interrupt enabled GPIO mask register

7	6	5	4	3	2	1	0
INT_EN_GPIO_MASK_LOW							
IEG7	IEG6	IEG5	IEG4	IEG3	IEG2	IEG1	IEG0
RW	RW	RW	RW	RW	RW	RW	RW
0	0	0	0	0	0	0	0
15	14	13	12	11	10	9	8
INT_EN_GPIO_MASK_MID							
IEG15	IEG14	IEG13	IEG12	IEG11	IEG10	IEG9	IEG8
RW	RW	RW	RW	RW	RW	RW	RW
0	0	0	0	0	0	0	0
23	22	21	20	19	18	17	16
INT_EN_GPIO_MASK_HIGH							
Reserved						IEG17	IEG16
R	R	R	R	R	R	RW	RW
0	0	0	0	0	0	0	0

Address: 0A, 0B, 0C

Type: R/W

Reset: 0x00

Description: The interrupt enable GPIO mask register is used to enable the interruption from a particular GPIO interrupt source to the host. The IEG[17:0] bits are the interrupt enable mask bits correspond to the GPIO[17:0] pins.

[17:0] IEG[x]: Interrupt enable GPIO mask (where x = 17 to 0)
 Writing a '1' to the IEG[x] bit enables the interruption to the host.

NT_STA_GPIO

Interrupt status GPIO register

7	6	5	4	3	2	1	0
INT_STA_GPIO_LOW							
ISG7	ISG6	ISG5	ISG4	ISG3	ISG2	ISG1	ISG0
R	R	R	R	R	R	R	R
0	0	0	0	0	0	0	0

15	14	13	12	11	10	9	8
INT_STA_GPIO_MID							
ISG15	ISG14	ISG13	ISG12	ISG11	ISG10	ISG9	ISG8
R	R	R	R	R	R	R	R
0	0	0	0	0	0	0	0

23	22	21	20	19	18	17	16
INT_STA_GPIO_HIGH							
Reserved						ISG17	ISG16
R	R	R	R	R	R	R	R
0	0	0	0	0	0	0	0

Address: 0D, 0E, 0F

Type: R

Reset: 0x00

Description: The interrupt status GPIO register monitors the status of the interruption from a particular GPIO pin interrupt source to the host. The INT_STA_GPIO bits are constantly updated regardless whether the INT_EN_GPIO_MASK bits are enabled or not. The ISG[17:0] bits are the interrupt status bits correspond to the GPIO[17:0] pins.

[17:0] ISG[x]

Interrupt status GPIO (where x = 17 to 0)

ISG[x] will be set to '1' if an interrupt is detected on the corresponding GPIO pin.

Reading the INT_STA_GPIO register clears all interrupt status GPIO bits to '0' which had been set to '1' prior to the read event.

9.3 Programming sequence

To configure and initialize the interrupt controller to allow interruption to host, observe the following steps:

1. Set the INT_EN_MASK and INT_EN_GPIO_MASK registers to the desired values to enable the interrupt sources that are to be expected to receive from.
2. Configure the output interrupt type and polarity and enable the global interrupt mask by writing to the INT_CTRL.
3. Wait for interrupt.
4. Upon receiving an interrupt, the corresponding INT bit is asserted.
5. The host comes to read the INT_STA register through the I²C interface. A '1' in the INT_STA bits indicates that the corresponding interrupt source is triggered.
6. If the IS3 bit in INT_STA register is set, the interrupt is coming from the GPIO controller. Then, a subsequent read is performed on the INT_STA_GPIO register to obtain the interrupt status of all 18 GPIOs to locate the GPIO that triggers the interrupt. This is a 'Hot Key' feature.
7. After obtaining the interrupt source that triggers the interrupt, the host performs the necessary processing and operations related to the interrupt source.
8. All IS[x] bits in INT_STA register and ISG[x] bits in INT_STA_GPIO register which are set to '1' prior to the read event are cleared to '0' automatically once the reading of the registers are completed.
9. Any interrupt inputs received between reading and auto clearing of the registers are kept in a shadow register and updated into the INT_STA and INT_STA_GPIO registers once the auto clearing is completed.
10. Once the interrupt is cleared, the INT pin is also de-asserted if the interrupt type is level interrupt. An edge interrupt only asserts a pulse width of 200 μ s.
11. When the interrupt function is no longer required, the IC0 bit in INT_CTRL may be set to '0' to disable the global interrupt mask bit.

10 GPIO controller

A total of 18 GPIOs are available in the STMPE1801 port expander device. Most of the GPIOs are sharing physical pins with alternate functions. The GPIO controller contains the registers that allow the host system to configure each of the pins into either a GPIO, or one of the alternate functions. Unused GPIOs should be configured as outputs to minimize the power consumption.

Table 13. GPIO controller registers

Address	Register name	Description	Auto-increment (during sequential R/W)
10	GPIO_SET_LOW	GPIO set pin state register	Yes
11	GPIO_SET_MID		Yes
12	GPIO_SET_HIGH		Yes
13	GPIO_CLR_LOW	GPIO clear pin state register	Yes
14	GPIO_CLR_MID		Yes
15	GPIO_CLR_HIGH		Yes
16	GPIO_MP_LOW	GPIO monitor pin state register	Yes
17	GPIO_MP_MID		Yes
18	GPIO_MP_HIGH		Yes
19	GPIO_SET_DIR_LOW	GPIO set pin direction register	Yes
1A	GPIO_SET_DIR_MID		Yes
1B	GPIO_SET_DIR_HIGH		Yes
1C	GPIO_RE_LOW	GPIO rising edge register	Yes
1D	GPIO_RE_MID		Yes
1E	GPIO_RE_HIGH		Yes
1F	GPIO_FE_LOW	GPIO falling edge register	Yes
20	GPIO_FE_MID		Yes
21	GPIO_FE_HIGH		Yes
22	GPIO_PULL_UP_LOW	GPIO pull up register	Yes
23	GPIO_PULL_UP_MID		Yes
24	GPIO_PULL_UP_HIGH		Yes

10.1 GPIO control registers

A group of registers is used to control the exact function of each of the 18 GPIOs.

All the GPIO registers are named as GPIO_xxx_yyy, where:

- xxx represents the functional group
- yyy represents the byte position of the GPIO (LOW/MID/HIGH)
- LOW registers control GPIO[7:0]
- MID registers control GPIO[8:15]
- HIGH registers control GPIO[17:16]

10.1.1 Bit description

	7	6	5	4	3	2	1	0
GPIO_xxx_HIGH	RESERVED						IO-16	IO-17
GPIO_xxx_MID	IO-15	IO-14	IO-13	IO-12	IO-11	IO-10	IO-9	IO-8
GPIO_xxx_LOW	IO-7	IO-6	IO-5	IO-4	IO-3	IO-2	IO-1	IO-0

The function of each bit is shown in the following table:

Register name	Description	Function
GPIO_MP_yyy	GPIO monitor pin state	Reading this bit yields the current state of the bit. Writing has no effect.
GPIO_SET_yyy	GPIO set pin state	Writing '1' to this bit causes the corresponding GPIO to go to '1' state. Writing '0' has no effect.
GPIO_CLR_yyy	GPIO clear pin state	Writing '1' to this bit causes the corresponding GPIO to go to '0' state. Writing '0' has no effect.
GPIO_SET_DIR_yyy	GPIO set pin direction	'0' sets the corresponding GPIO to input state, and '1' sets it to output state.
GPIO_RE_yyy	GPIO rising edge	Set to '1' enable rising edge detection on the corresponding GPIO.
GPIO_FE_yyy	GPIO falling edge	Set to '1' enable falling edge detection on the corresponding GPIO.
GPIO_PULL_UP_yyy	GPIO pull up	Set to '1' enable internal pull-up resistor.

10.2 Hotkey feature

A GPIO is known as 'Hotkey' when it is configured to trigger an interruption to the host whenever the GPIO input is being asserted. This feature is applicable in operational mode as well as in Hibernate mode.

10.2.1 Programming sequence for Hotkey

1. Configure the GPIO pin into input direction by setting the corresponding bit in the GPIO set pin direction registers [GPIO_SET_DIR_yyy].
2. Set the GPIO rising edge registers [GPIO_RE_yyy] and GPIO falling edge registers [GPIO_FE_yyy] to the desired values to enable the rising edge or falling edge detection.
3. Configure and enable the interrupt controller to allow the interruption to the host.
4. Now, the GPIO expander may enter Hibernate mode if there is no activity.
5. Upon any hot-key being asserted, the device will wake up and issue an interrupt to the host.

Below are the conditions to be fulfilled in order to configure a Hot Key:

1. The pin is configured into GPIO mode and as input pin.
2. The global interrupt mask bit is enabled.
3. The corresponding GPIO interrupt mask bit is enabled.

10.2.2 Minimum pulse width

The minimum pulse width of the assertion of the Hotkey is dependent on the de-bounce time configured. It must be greater than the de-bounce value configured. Any pulse width less than the stated value may not be registered.

11 Keypad controller

The keypad controller consists of:

- 4 dedicated key controllers that support up to 4 simultaneous dedicated key presses;
- a keyscan controller support a maximum of 10 x 8 key matrix with detection of three simultaneous key presses;
- 8 special function key controllers that support up to 8 simultaneous “special function” key presses.

The key detection priority is dedicated, special function and normal keys.

Four of the row inputs can be configured as dedicated keys through the setting of Dkey0~3 bits of the KPC_CTRL register. The normal key matrix size can be configured through the setting of KPC_ROW and KPC_COL registers. The scanning of each individual row input and column output can be enabled or masked to support a key matrix of variable size from 1 x 1 to 10 x 8. It is allowed to have other 8 special function keys incorporated in the key matrix.

The operation of the keypad controller is enabled by the SCAN bit of KPC_CTRL register. Every key activity detected is de-bounced for a period set by the DB_1~7 bits of KPC_CTRL register before a key press or key release is confirmed and updated into the output FIFO. The key data, indicating the key coordinates and its status (up or down), is loaded into the FIFO at the end of a specified number of scanning cycles (set by SCAN_COUNT0~3 bits of KPC_CTRL_MID register). An interrupt is generated when a new set of key data is loaded. The FIFO has a capacity for ten sets of key data. Each set of key data consists of 5 bytes of information when any of the four dedicated keys is enabled. It is reduced to 4 bytes when no dedicated key is involved. When the FIFO is full before its content is read, an overflow signal is generated while the FIFO will continue to hold its content but forbid loading of new key data set.

Figure 7. Keypad controller

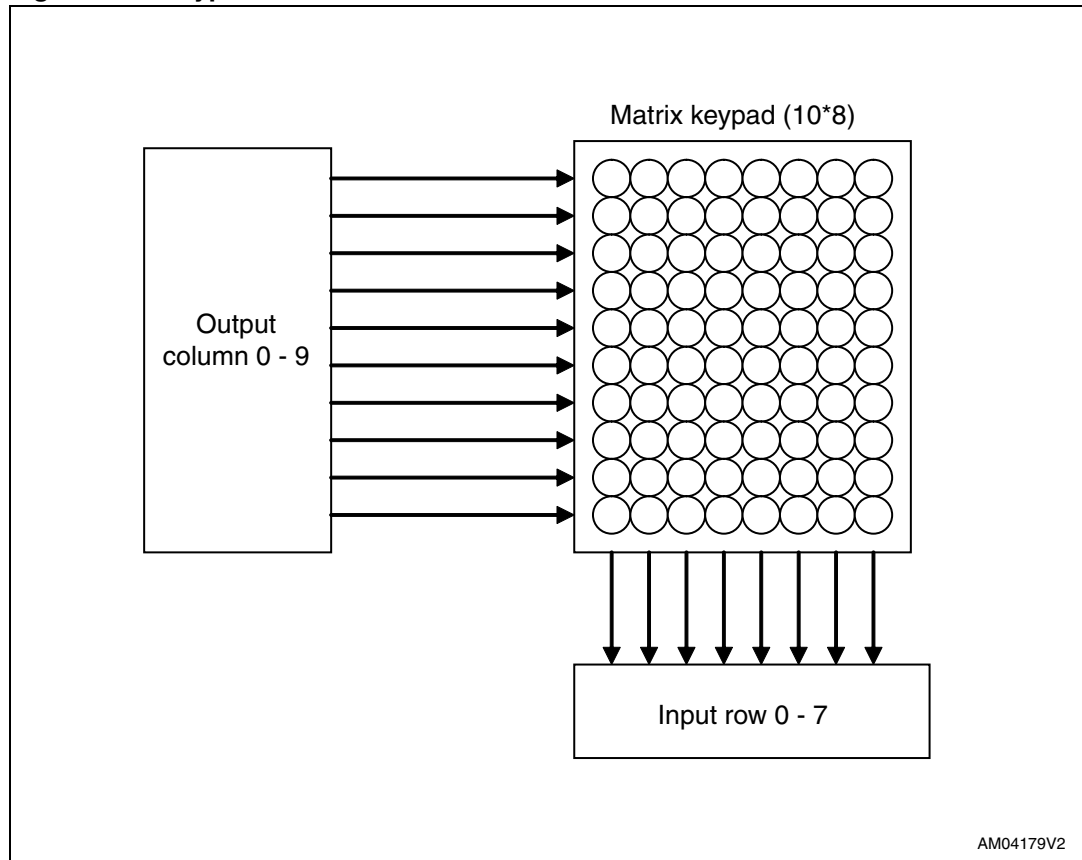

The keypad rows enabled by the KPC_ROW register are normally 'high', with the corresponding input pins pulled up by resistors internally. After reset, all the keypad columns enabled by the KPC_COL register are driven 'low' via weak-pull down resistors. The pull-down resistors on the column are weaker than the pull-up resistors on the rows. If a key is pressed, the stronger pull-up drive on the corresponding row overwrites the weaker pull-down drive on the selected column thus allowing the keyscan controller to sense a "high" input on the selected column.

Once the keyscan controller senses a "high" on the selected column, the output buffer for the selected column drives the line low overwriting the pull-up resistor on the corresponding row. The row that senses the "low" signal enables the key scan controller to decode the key coordinates (its corresponding row number and column number), save the key data into a de-bounce buffer if available, confirm if it is a valid key press after de-bouncing, and update the key data into output data FIFO if valid.

The key press/release detection mechanism is listed below:

1. When the GPIO is configured as keypad, the ROWS have internal "strong" pull-up and COLUMNS have internal "weak" pull-down. The initial states of the ROWS are Logic High and the COLUMNS are Logic Low.
2. When a keypad is pressed, the corresponding Row and Column form a Resistor Voltage Divider Network. Since the pull-up resistance of the ROW is stronger than the pull-down resistance of the COLUMN, the COLUMN is pulled to Logic High.
3. Once the COLUMN's state changes to Logic High, the state machine initiates a key-scan cycle and drives the selected COLUMN to Logic Low. A low is detected on the

key-press ROW. This is because the row and column node of key press are shorted together.

4. The state machine continues to poll while the key is still pressed and is reinitialized once all the keys are released.

The key detection sequence is described below:

1. The column outputs are initially not driven.
2. Then the row inputs are checked for any special function keys.
3. Next, the columns are checked for any normal key presses.
4. With the internal pull-down resistor on the columns, the column senses a logic low. But when there is a normal key press, the pull up on the row and pull down on the column forms a resistor voltage divider. Since the pull up resistor is sized much smaller than the pull down resistor, the voltage on the column is pulled to logic high state.
5. Then only the configured columns that sensed a high are driven low in turn and check for normal key presses.

This eliminates the need to drive columns that do not have any key press. This in turn reduces the switching amount and hence the reduction in noise and EMI.

Also the 4 mA IO during GPIO mode is 1 mA in keypad mode.

11.1 Keypad configurations

The keypad controller supports the following types of keys:

- Up to 10 columns * 8 rows matrix keys
- Up to 8 special function keys
- Up to 4 dedicated keys

Figure 8. Keypad configuration

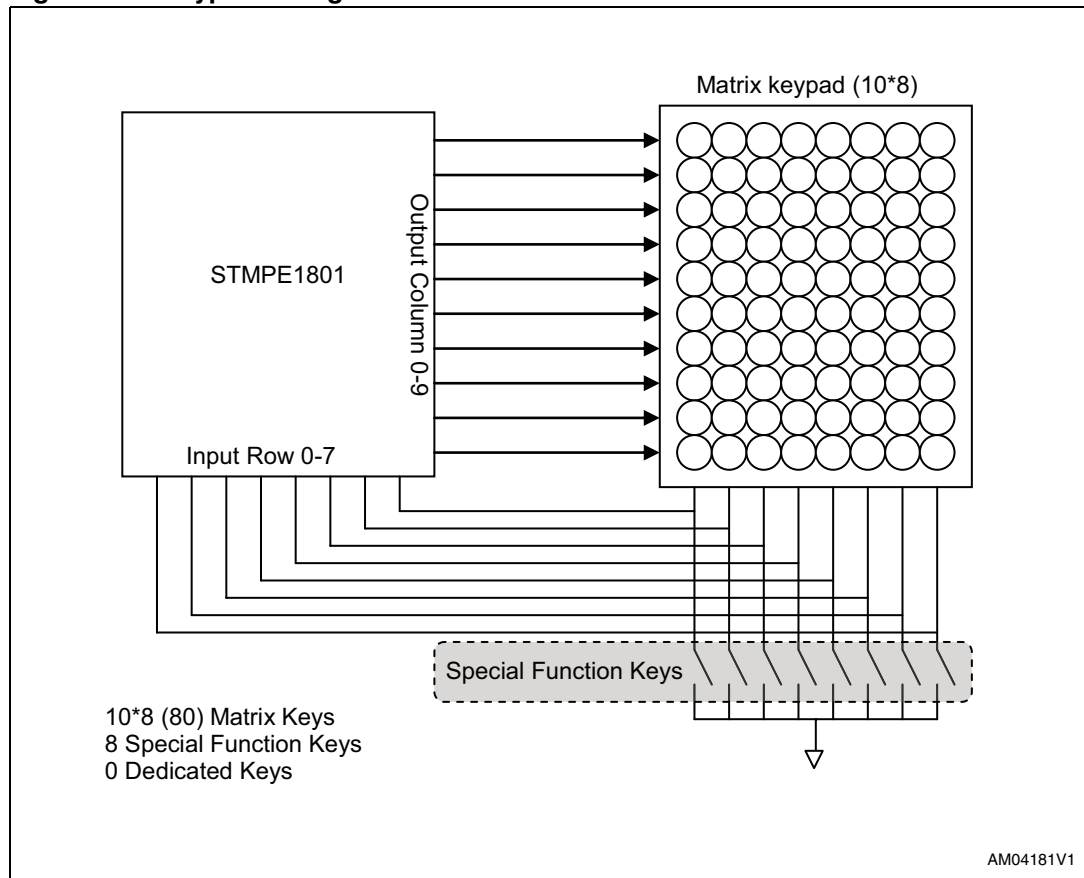
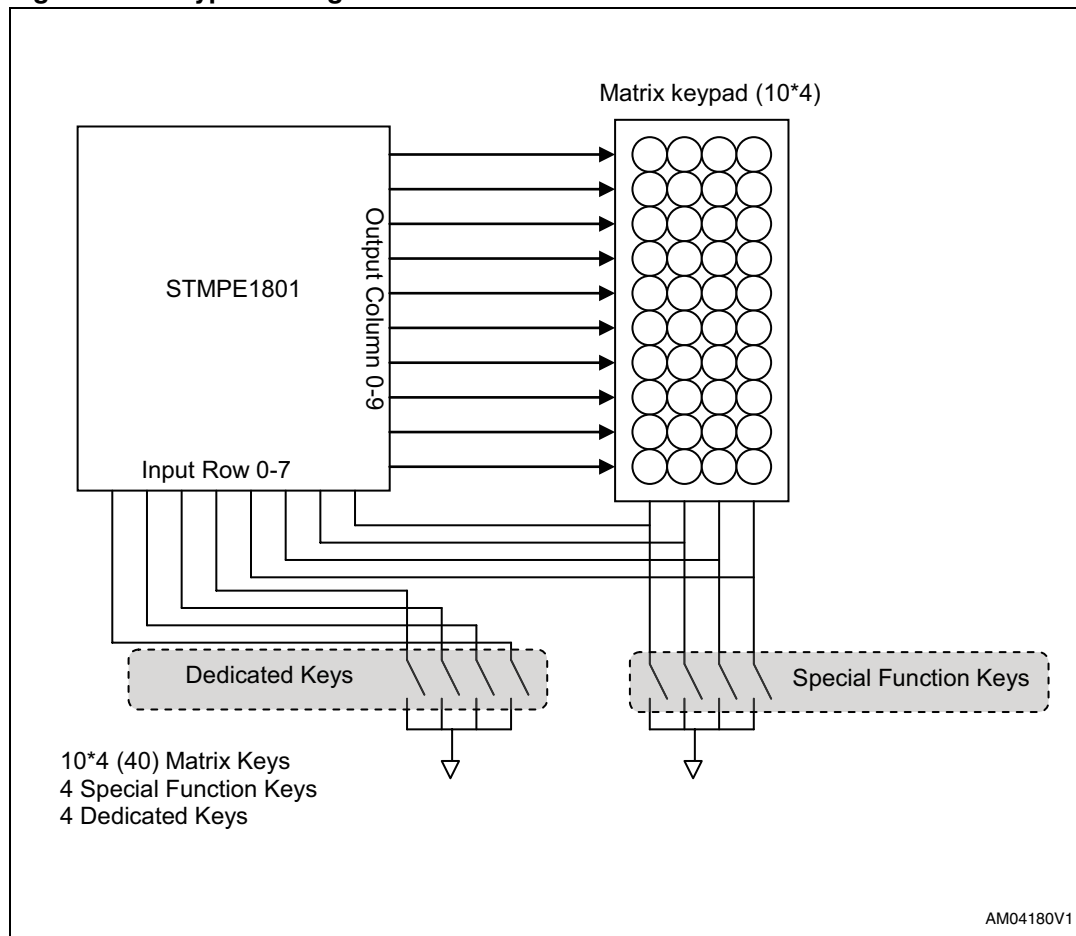

Figure 9. Keypad configurations



11.2 Keypad controller registers

The mapping between the keypad controller (rows and columns) and the GPIO is based on [Section 2.3](#).

Table 14. Keypad controller registers

Address	Register name	Description	Auto-increment (during sequential R/W)
30	KPC_ROW	Keypad row register	Yes
31	KPC_COL_LOW	Keypad column register	Yes
32	KPC_COL_HIGH		Yes
33	KPC_CTRL_LOW	Keypad control register	Yes
34	KPC_CTRL_MID		Yes
35	KPC_CTRL_HIGH		Yes
36	KPC_CMD	Key command register	Yes
37	KPC_COMBI_KEY_0	Keypad combination key mask 0	Yes
38	KPC_COMBI_KEY_1	Keypad combination key mask 1	Yes
39	KPC_COMBI_KEY_2	Keypad combination key mask 2	Yes
3A	KPC_DATA_BYTE0	Keypad data register	Yes
3B	KPC_DATA_BYTE1		Yes
3C	KPC_DATA_BYTE2		Yes
3D	KPC_DATA_BYTE3		Yes
3E	KPC_DATA_BYTE4		Yes

KPC_ROW

Keypad controller row register

7	6	5	4	3	2	1	0
Input Row 0 - 7							
RW	RW	RW	RW	RW	RW	RW	RW
0	0	0	0	0	0	0	0

Address: 30

Type: R/W

Reset: 0x00

Description: Keypad row scanning

[7:0] Input row 0 – 7:

‘1’: Turn on scanning of the corresponding row

‘0’: Turn off

KPC_COL_HIGH

Keypad controller column (HIGH)

15	14	13	12	11	10	9	8
RESERVED						Output Column 8 - 9	
R	R	R	R	R	R	RW	RW
0	0	0	0	0	0	0	0

Address: 32

Type: R/W

Reset: 0x00

Description: Keypad column scanning register.

[15:10] RESERVED

[9:8] OUTPUT COLUMN 8-9:

‘1’: Turn on scanning of the corresponding column.

‘0’: Turn off

KPC_COL_LOW

Keypad controller column (LOW)

7	6	5	4	3	2	1	0
Output Column 0 - 7							
RW	RW	RW	RW	RW	RW	RW	RW
0	0	0	0	0	0	0	0

Address: 31

Type: R/W

Reset: 0x00

Description: Keypad column scanning register.

- [7:0] OUTPUT COLUMN 0-7:
 '1': Turn on scanning of the corresponding column.
 '0': Turn off

KPC_CTRL_LOW

Keypad controller control (Low)

7	6	5	4	3	2	1	0
SCAN_COUNT 0 – 3				DKEY 0 – 3			
RW	RW	RW	RW	RW	RW	RW	RW
0	0	0	0	0	0	0	0

Address: 33

Type: R/W

Reset: 0x00

Description: Keypad control register.

- [7:4] SCAN_COUNT_0-3:
 Number of key scanning cycles elapsed before a confirmed key data is updated into output data FIFO (0-15 cycles)
- [3] DKEY_3: Set '1' to use input row 3 as dedicated key
- [2] DKEY_2: Set '1' to use input row 2 as dedicated key
- [1] DKEY_1: Set '1' to use input row 1 as dedicated key
- [0] DKEY_0: Set '1' to use input row 0 as dedicated key

KPC_CTRL_MID

Keypad controller control (Mid)

7	6	5	4	3	2	1	0
DB[7:2]						DB0	RSVD
RW	RW	RW	RW	RW	RW	R	RW
0	1	1	0	0	0	1	0

Address: 34

Type: R/W

Reset: 0x31

Description: Keypad control register.

[7:1] DB[7:2] and DB0:

DB0 bit is fixed to '1'.

10-127ms of de-bounce time

De-bounce time range is from 10 ms to 127 ms with 50 ms as the default.

[0] RESERVED

KPC_CTRL_HIGH

Keypad controller control (High)

7	6	5	4	3	2	1	0
RSVD	CMB_KEY	RESERVED				SCAN_FREQ	
R	RW	R	R	R	R	RW	
0	1	0	0	0	0	0	0

Address: 35

Type: R/W, R

Reset: 0x40

Description: Keypad data register.

[7:4] RESERVED

[6] CMB_KEY:

Combination key mode

1: AND function for combination-key interrupt (default).

0: OR function for combination-key interrupt.

[5:2] RESERVED

[1:0] SCAN_FREQ:

Scan frequency based on internal 32KHz clock

00: 60 Hz (default)

01: 30 Hz

10: 15 Hz

11: 275 Hz

KPC_CMD

Keypad command register

7	6	5	4	3	2	1	0
RSVD	RSVD	RSVD	RSVD	RSVD	RSVD	KPC_LOCK	SCAN
R	R	R	R	R	R	RW	RW
0	0	0	0	0	0	0	

Address: 36

Type: R/W, R

Reset: 0x00

Description: Keypad command register.

[7:2] RESERVED

[1] KPC_LOCK:

Keypad lock control bit

1: Writing 1 to enter key pad lock state when the key press stops.

The KPC_LOCK bit is only used when a combination key is configured in the device. If there is no combination key programmed, then this bit is not used. This command is used in conjunction with the combination keys. After the device has entered the keypad lock state, all subsequent key presses are ignored until the combinational key(s) are detected. Thereafter, the device exits the lock state, sets the combinational key wakeup status in the interrupt status register bit IS[4] and sends out the interrupt if it was enabled.

0: Writing 0 aborts the key lock

Writing a 0 to this bit cancels any earlier key lock execution command. If the device has already entered the lock state, writing 0 exits the lock state.

This bit is readable by the Host and the read status is described as follows:

Reading [1]: KPC lock execution is not completed. It is either waiting for the key press to stop to enter the lock state or it is already in the lock state.

Reading [0]: KPC is already not in lock state, and not waiting to enter lock state.

[0]SCAN:

1: to start scanning

0: to stop

Note: All the key configurations and control must be completed before executing the scan command. Any configuration and control change while scan is active is not supported.

11.3 Data registers

The KPC_DATA register contains five bytes of information. The first three bytes store the key coordinates and status of any three keys from the normal key matrix, while the fourth byte stores the status of special function keys and the fifth byte consists of the status of dedicated keys.

Note: When accessing the KPC DATA FIFO, it is mandatory to read all five bytes of KPC_Data registers together consecutively.

KPC_DATA_BYTE0

Keypad data byte 0

7	6	5	4	3	2	1	0
UP/DWN	C3	C2	C1	C0	R2	R1	R0
R	R	R	R	R	R	R	R
1	1	1	1	1	0	0	0

Address: 3A

Type: R

Reset: 0xF8

Description: Keypad data register.

[7] UP/DWN:

0: key-down

1: key-up

[6:3] C[3:0]:

Column number of key 1 (valid range: 0000-1001)

0x1111: No key

[2:0] R[2:0]:

Row number of key 1 (valid range: 000-111)

KPC_DATA_BYTE1

Keypad data byte 1

7	6	5	4	3	2	1	0
UP/DOWN	C3	C2	C1	C0	R2	R1	R0
R	R	R	R	R	R	R	R
1	1	1	1	1	0	0	0

Address: 3B

Type: R

Reset: 0xF8

Description: Keypad data register.

[7] UP/DOWN:

0: key-down

1: key-up

[6:3] C[3:0]:

Column number of key 2 (valid range: 0000-1001)

0x1111: No key

[2:0] Row number of key 2 (valid range: 000-111)

KPC_DATA_BYTE2**Keypad data byte 2**

7	6	5	4	3	2	1	0
UP/DOWN	C3	C2	C1	C0	R2	R1	R0
R	R	R	R	R	R	R	R
1	1	1	1	1	0	0	0

Address: 3C**Type:** R**Reset:** 0xF8**Description:** Keypad data register.

[7] UP/DOWN:

0: key-down

1: key-up

[6:3] C[3:0]: Column number of key 3 (valid range: 0000-1001)

0x1111: No key

[2:0] R[2:0]: Row number of key 3 (valid range: 000-111)

KPC_DATA_BYTE3**Keypad data byte 3**

7	6	5	4	3	2	1	0
SF7	SF6	SF5	SF4	SF3	SF2	SF1	SF0
R	R	R	R	R	R	R	R
1	1	1	1	1	1	1	1

Address: 3D**Type:** R**Reset:** 0xFF**Description:** Keypad data register.

[7:0] SF[7:0]:

0: key-down

1: key-up

KPC_DATA_BYTE4

Keypad data byte 4

7	6	5	4	3	2	1	0
RESERVED				Dedicated Key 0 – 3			
R	R	R	R	R	R	R	R
0	0	0	0	1	1	1	1

Address: 3E

Type: R

Reset: 0x0F

Description: Keypad data register.

[7:4] RESERVED

[3:0] Dedicated key [3:0]:

0: Key down

1: Key up

11.4 Keypad combination key registers

The 3 keypad controller mask registers contains the key combination to be used to wake up the KPC and send an interrupt to the host system.

KPC_COMB_KEY_n

Keypad combination [n = 0-2]

7	6	5	4	3	2	1	0
C4	C3	C2	C1	C0	R2	R1	R0
RW	RW	RW	RW	RW	RW	RW	RW
1	1	1	1	1	0	0	0

Address: 38, 39

Type: R/W

Reset: 0xF8

Description: Keypad combination key mask registers.

[7:3] C[4:0]: Column number of key n (valid range: 00000 – 01001)

[2:0] R[2:0]: Row number of key n (valid range: 000 – 111)

Valid key press value must be entered. The valid range for STMPE1801 is 00 to 4F. Any other value outside this range is not accepted and a none value of F8 is returned.

11.5 Using the keypad controller

It is not necessary to explicitly enable the internal pull-up, pull-down and direction by configuring the GPIO control registers. Once a GPIO is enabled for the keypad function, its internal pull-up, pull-down and direction is controlled automatically.

The scanning of row inputs should then be enabled for those GPIO ports that are configured as keypad inputs by writing '1's to the corresponding bits in the KPC_ROW register. If any of the first four row inputs is to be used as dedicated key input, the corresponding bits in the KPC_CTRL_MID register should be set to '1'. The bits in the KPC_COL_HIGH and KPC_COL_LOW registers should also be set correctly to enable the column output scanning for the corresponding GPIO ports programmed as keypad outputs.

The scan count and de-bounce count should also be programmed into the keypad control registers before enabling the keypad controller operation. To enable the keypad controller operation, the SCAN bit in the KPC_CTRL_LOW register must be set to '1'. The keypad controller operation can be disabled by setting the SCAN bit back to '0'. The KPC interrupt can be cleared upon status bit read, even if there is unread key-press in the KPC Data register. It is the host responsibility to read the KPC Data register to access all key-press data.

11.5.1 Ghost key handling

The ghost key is inherent in keypad matrix that is not equipped with a diode at each of the keys. While it is not possible to avoid ghost key occurrence, the STMPE1801 allows the detection of possible ghost keys by the capability of detecting 3 simultaneous key-presses in the key matrix.

The ghost key is only possible if 3 keys are pressed and held down together in a keypad matrix. If 3 keys are reported by the STMPE1801 keypad controller, it indicates a potential ghost key situation. The system may check for the possibility of a ghost key by analyzing the coordinates of the 3 keys. If the 3 keys form 3 corners of a rectangle, it could be a ghost key situation.

A ghost key may also occur in the "special function keys". The keypad controller does not attempt to avoid the occurrence of ghost keys. However, the system should be aware that if more than one special function key is reported, then there is a possibility of ghost keys.

11.5.2 Key detection priority

A dedicated key is always detected, if this is enabled. When a special function key is detected, the matrix key scanning on the same input line is disabled.

Up to 3 matrix keys can be detected. Matrix keys that fall on activated special function keys are not counted.

As a result of these priority rules, a matrix key is ignored by the keypad controller when the special function key on the same input line is detected, even if the matrix key is being pressed down before the special function key. Hence, when a matrix is reported "key-down" and it is being held down while the corresponding special function is being pressed, a "no key" status is reported for the matrix key when the special function key is reported "key-down". If the matrix key is released while the special function key is still being held down, no "key-up" will be reported for the matrix key. On the other hand, if the matrix key is released after the special function key is reported "key-up", then a new "key-down" is reported for the matrix key, followed by "key-up".

11.5.3 Keypad wakeup from Hibernate mode

The keypad controller is functional in Hibernate mode as long as it is enabled before entering the Hibernate mode. It will then wake the system up into operational mode if a valid key press is detected.

An asynchronous detection of the keypad column input activity is turned on during the Hibernate mode. If any key activity is detected, the system wakes up into operational mode for the de-bouncing of the key press to take place. If a valid key is detected, the system stays in operational mode; otherwise, the device goes back into Hibernate mode.

11.5.4 Keypad controller combination key interrupt

The keypad controller (KPC) can be programmed to exit from Hibernate mode if a unique combination keys is detected. These combination keys of up to 3 keys are specified in the KPC combination set 0-2 registers.

There are 2 combination key operation modes. The modes can be set in the COMB_KEY_MODE in the KPC_CTRL_HIGH register. In 'OR' mode, the device exits from Hibernate mode on ANY of the 3 keys specified in the KPC combination set 0-2 registers. In 'AND' mode, the device exits from Hibernate mode ONLY if ALL of the 3 keys are pressed. The sequence of the key pressed is not relevant as long as the 1-3 keys specified in the KPC_COMB_KEY registers are detected, the KPC will exit from Hibernate mode and interrupt the host. All the "active" keys must be pressed and held together, for the combi-key interrupt to be generated.

If any other keys (beside those specified in the KPC_COMB_KEY_N registers) are pressed, it would be considered an invalid combination and no interrupt will be generated.

12 Miscellaneous features

12.1 Reset

The STMPE1801 is equipped with an internal POR circuit that holds the device in reset state, until the clock is steady and V_{CC} input is valid. The POR circuit is integrated with a filter with minimum 180 ns at 1.8 V V_{CC} . The host system may choose to reset the STMPE1801 by asserting the RSTB pin. The reset pin is also integrated with a filter of minimum 200 μ s duration and maximum 500 μ s duration.

13 Package mechanical data

In order to meet environmental requirements, ST offers these devices in different grades of ECOPACK® packages, depending on their level of environmental compliance. ECOPACK® specifications, grade definitions and product status are available at: www.st.com. ECOPACK® is an ST trademark.

Figure 10. Package outline for Flip-chip CSP 25 (2.03 x 2.03 mm) - 0.4 mm pitch

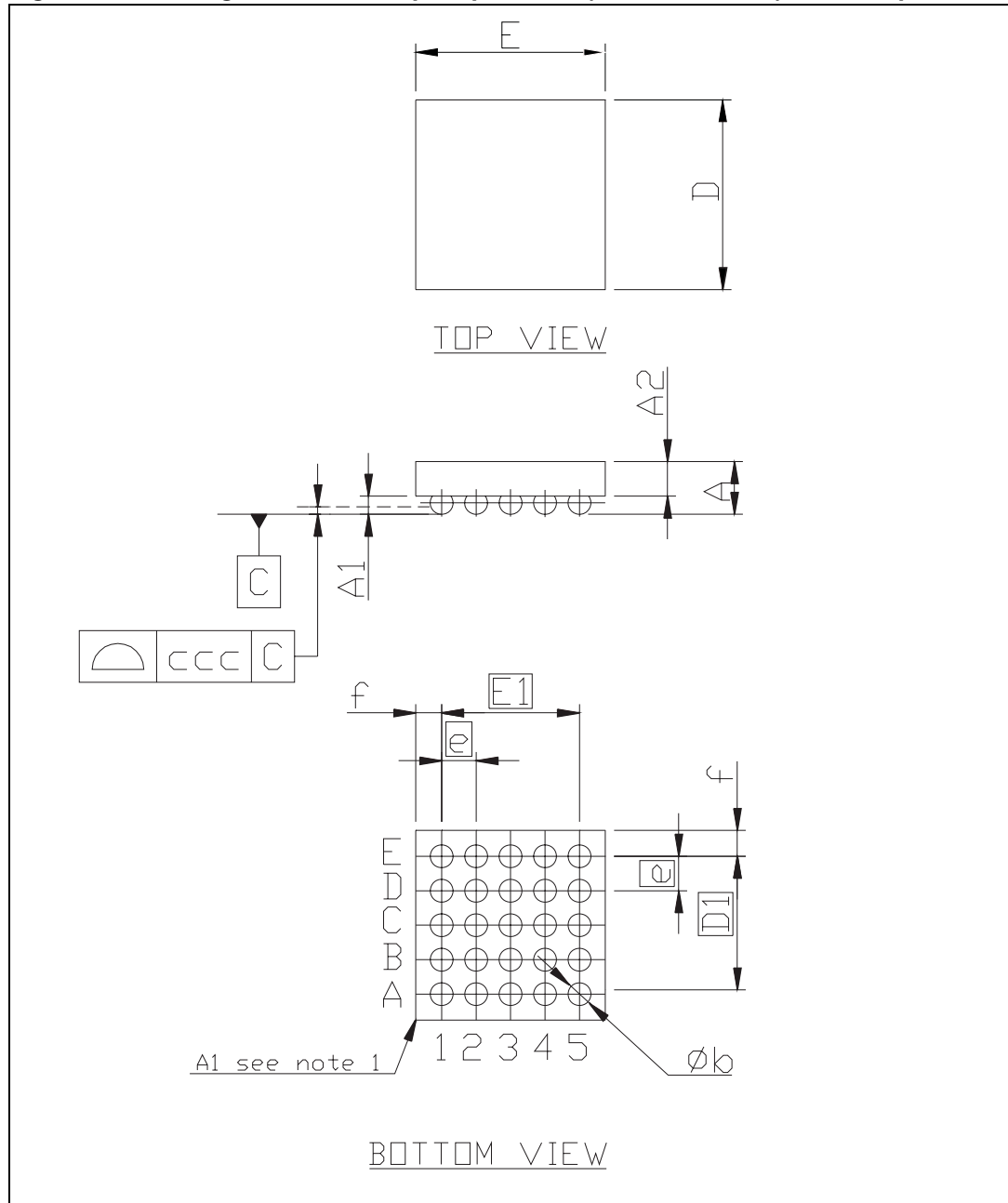

**Table 15. Package mechanical data for Flip-chip CSP 25 (2.03 x 2.03 mm)
0.4 mm pitch**

Symbol	Millimeters		
	Min	Typ	Max
A	0.55	0.605	0.660
A1	0.17	0.205	0.24
A2	0.38	0.4	0.42
b	0.215	0.255	0.295
D	1.97	2	2.03
D1	-	1.6	-
E	1.97	2	2.03
E1	-	1.6	-
e	0.36	0.4	0.44
f	0.190	0.200	0.210
ccc	-	0.05	0.05

Figure 11. Footprint recommendation

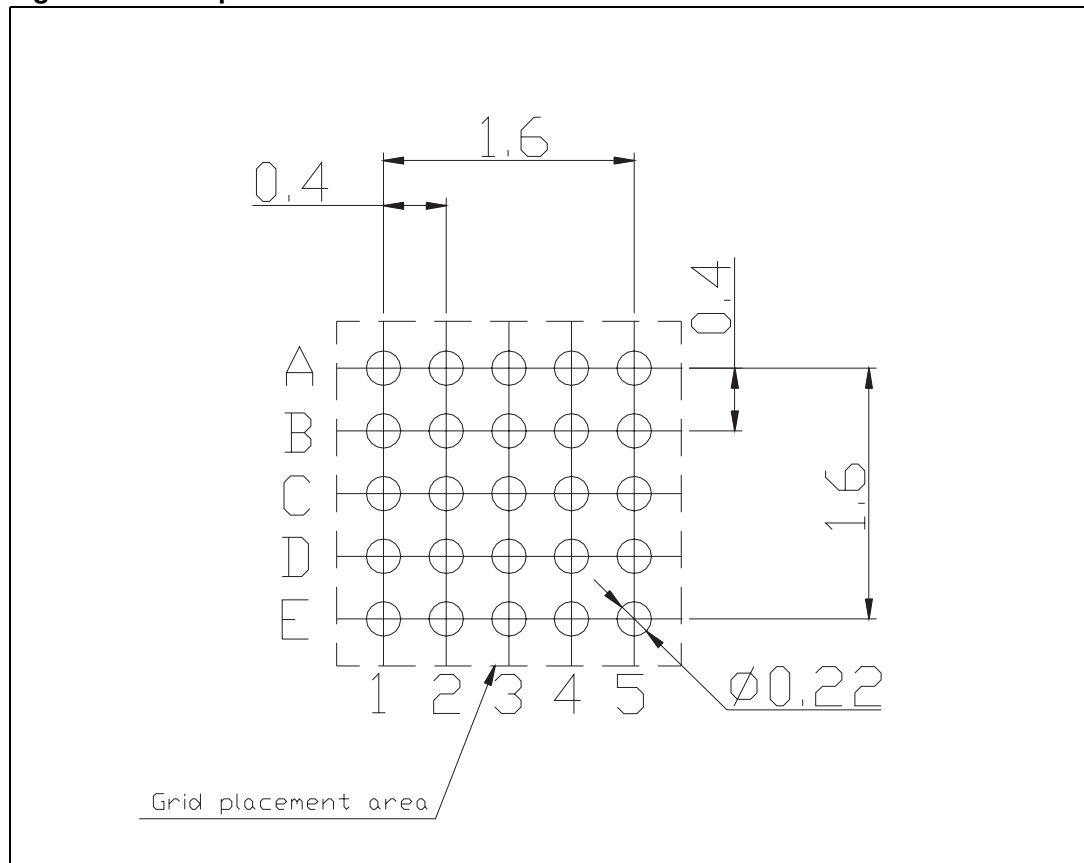

Figure 12. Device marking

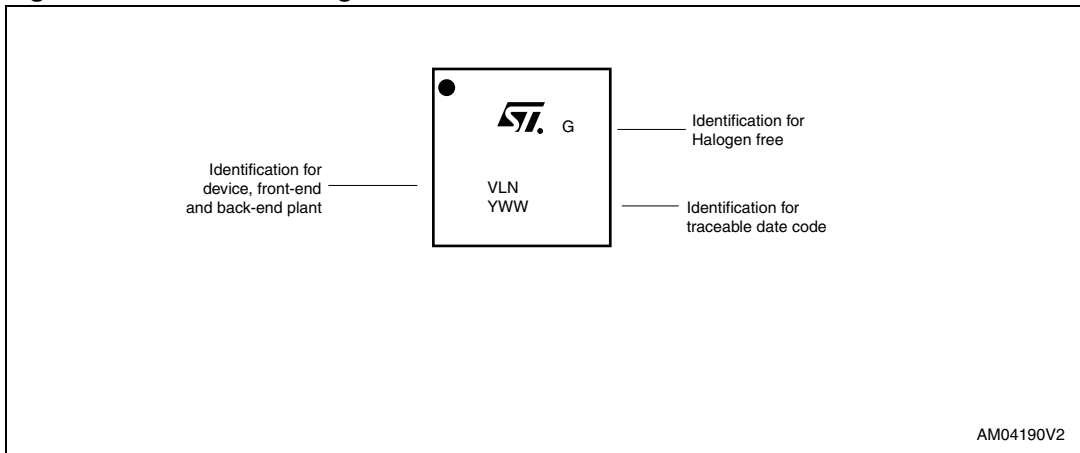
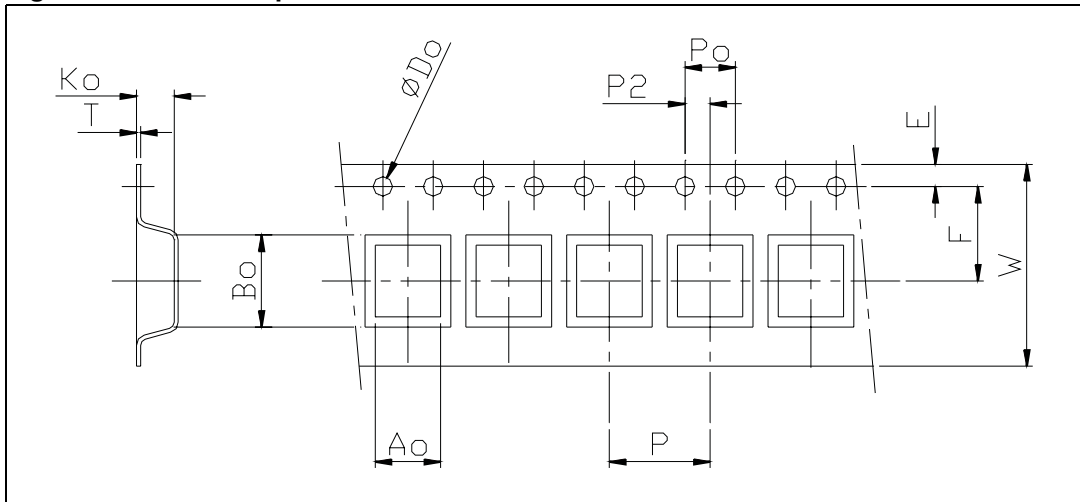

Figure 13. Carrier tape information



- 1. Pin A1 is at top left corner based on above tape orientation.

Table 16. Carrier tape specifications

Symbol	Millimeters		
	Min	Typ	Max
A0	2.06	2.11	2.16
B0	2.06	2.11	2.16
K0	0.64	0.69	0.74
F	3.45	3.50	3.55
W	7.90	8.00	8.30
P2	1.95	2.00	2.05
P0	3.90	4.00	4.10
10P0	39.80	40.00	40.20
D0	1.50	1.55	1.60
T	0.185	0.200	0.215
P	3.90	4.00	4.10

Table 17. Tape width (millimeters)

Tape width	A	N	W1	W2	W3	
	max	min	max	max	min	max
8	180	60	8,4	14.4	7.9	10.9

Figure 14. Reel drawing (front)

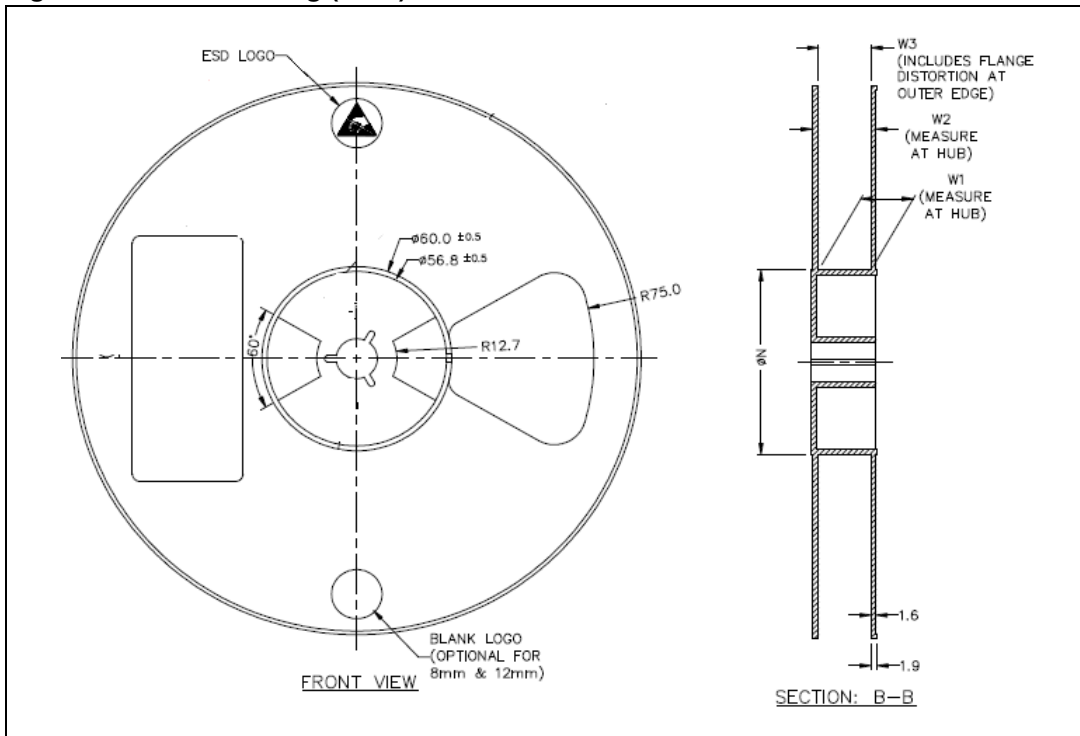
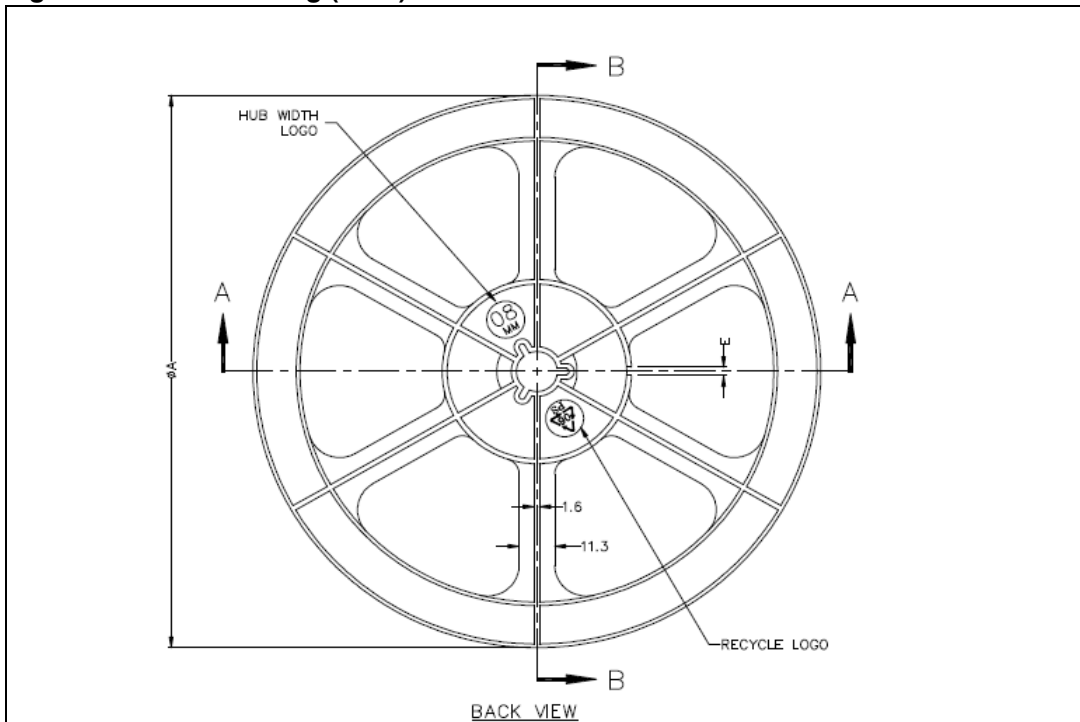

Figure 15. Reel drawing (back)



14 Revision history

Table 18. Document revision history

Date	Revision	Changes
15-Nov-2010	1	Initial release.
13-Dec-2010	2	Updated: Figure 12 and added footnote related to Figure 13 .
09-Mar-2011	3	Updated: Pin A1 function in Table 2 and Section 12.1 .

Please Read Carefully:

Information in this document is provided solely in connection with ST products. STMicroelectronics NV and its subsidiaries ("ST") reserve the right to make changes, corrections, modifications or improvements, to this document, and the products and services described herein at any time, without notice.

All ST products are sold pursuant to ST's terms and conditions of sale.

Purchasers are solely responsible for the choice, selection and use of the ST products and services described herein, and ST assumes no liability whatsoever relating to the choice, selection or use of the ST products and services described herein.

No license, express or implied, by estoppel or otherwise, to any intellectual property rights is granted under this document. If any part of this document refers to any third party products or services it shall not be deemed a license grant by ST for the use of such third party products or services, or any intellectual property contained therein or considered as a warranty covering the use in any manner whatsoever of such third party products or services or any intellectual property contained therein.

UNLESS OTHERWISE SET FORTH IN ST'S TERMS AND CONDITIONS OF SALE ST DISCLAIMS ANY EXPRESS OR IMPLIED WARRANTY WITH RESPECT TO THE USE AND/OR SALE OF ST PRODUCTS INCLUDING WITHOUT LIMITATION IMPLIED WARRANTIES OF MERCHANTABILITY, FITNESS FOR A PARTICULAR PURPOSE (AND THEIR EQUIVALENTS UNDER THE LAWS OF ANY JURISDICTION), OR INFRINGEMENT OF ANY PATENT, COPYRIGHT OR OTHER INTELLECTUAL PROPERTY RIGHT.

UNLESS EXPRESSLY APPROVED IN WRITING BY AN AUTHORIZED ST REPRESENTATIVE, ST PRODUCTS ARE NOT RECOMMENDED, AUTHORIZED OR WARRANTED FOR USE IN MILITARY, AIR CRAFT, SPACE, LIFE SAVING, OR LIFE SUSTAINING APPLICATIONS, NOR IN PRODUCTS OR SYSTEMS WHERE FAILURE OR MALFUNCTION MAY RESULT IN PERSONAL INJURY, DEATH, OR SEVERE PROPERTY OR ENVIRONMENTAL DAMAGE. ST PRODUCTS WHICH ARE NOT SPECIFIED AS "AUTOMOTIVE GRADE" MAY ONLY BE USED IN AUTOMOTIVE APPLICATIONS AT USER'S OWN RISK.

Resale of ST products with provisions different from the statements and/or technical features set forth in this document shall immediately void any warranty granted by ST for the ST product or service described herein and shall not create or extend in any manner whatsoever, any liability of ST.

ST and the ST logo are trademarks or registered trademarks of ST in various countries.

Information in this document supersedes and replaces all information previously supplied.

The ST logo is a registered trademark of STMicroelectronics. All other names are the property of their respective owners.

© 2011 STMicroelectronics - All rights reserved

STMicroelectronics group of companies

Australia - Belgium - Brazil - Canada - China - Czech Republic - Finland - France - Germany - Hong Kong - India - Israel - Italy - Japan - Malaysia - Malta - Morocco - Philippines - Singapore - Spain - Sweden - Switzerland - United Kingdom - United States of America

www.st.com