

Features

- Quad voltage monitoring
- Accurate $\pm 1.8\%$ across temperature voltage threshold ($\pm 1\%$ at 25°C)
- Primary supply (V_{CC}) monitor. Fixed (factory-programmed) reset thresholds: 3.078 V to 2.188 V
- Second fixed (V_{2IN}) monitor. Fixed (factory-programmed) reset thresholds: 2.333 V to 1.110 V
- Two additional adjustable supply monitor inputs (externally adjustable)
- 0.6V internal reference
- $\overline{\text{RST}}$ output (open drain)
- Output guaranteed for $V_{CC} \geq 0.8\text{ V}$
- Reset delay time (t_{REC}) pin selectable
- Manual reset input ($\overline{\text{MR}}$)
- Low supply current of $12\ \mu\text{A}$ (typ)
- Power supply voltage 0.8 V to 5.5 V
- RoHS compliant (green package)
- 8-pin MSOP/TSSOP
- Operating temperature: -40°C to 85°C (industrial grade)

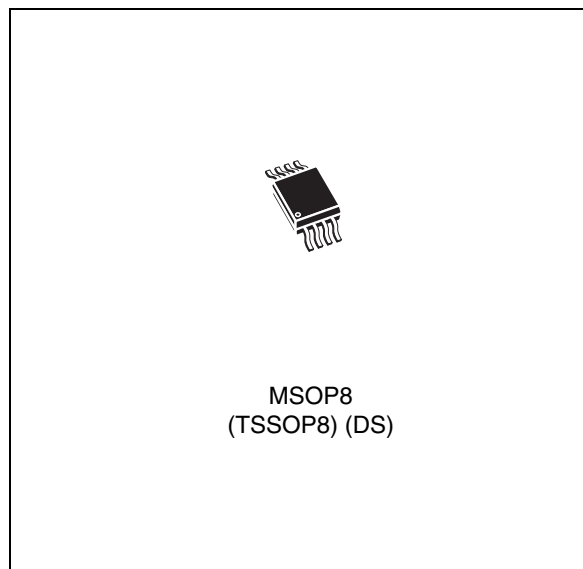

Applications

- Set-top boxes
- Multi-voltage systems
- Cable/satellite applications
- Computer systems
- Data storage equipment

Table 1. Device summary⁽¹⁾

Order code	V_{RST1} (V)	V_{RST2} (V)	t_{REC} (ms)	Package
STM6904TZEDS6F	3.078	2.333	210	MSOP8(TSSOP8)
STM6904TWEDS6F	3.078	1.683	210	MSOP8(TSSOP8)
STM6904TGEDS6F	3.078	1.110	210	MSOP8(TSSOP8)
STM6904SYEDS6F	2.955	2.188	210	MSOP8(TSSOP8)
STM6904SFEDS6F	2.955	1.050	210	MSOP8(TSSOP8)
STM6904PWEDS6F	2.866	1.683	210	MSOP8(TSSOP8)

1. Other reset threshold voltages and t_{REC} time-out periods are offered. Minimum order quantities may apply. Contact local ST sales office for availability.

Contents

1	Description	5
2	Pin descriptions	7
2.1	Push-button reset input (\overline{MR})	7
2.2	V_{CC} primary supply voltage monitoring input	7
2.3	V2IN second fixed voltage monitoring input	7
2.4	V_{SS}	7
2.5	V3IN and V4IN	7
2.6	\overline{RST} active-low, open drain reset output	7
2.7	TR _{SEL} input	8
3	Operation	10
3.1	Setting the adjustable voltage levels for V3IN and V4IN inputs	10
3.2	Power on reset (t_{REC})	10
4	Voltage monitoring	11
5	Maximum rating	12
6	DC and AC parameters	13
7	Package mechanical data	16
8	Part numbering	18
9	Package marking information	19
10	Revision history	20

List of tables

Table 1.	Device summary	1
Table 2.	Signal names and functions	6
Table 3.	Absolute maximum ratings	12
Table 4.	DC and AC characteristics	13
Table 5.	TSSOP 8-lead package mechanical data	17
Table 6.	Ordering information scheme	18
Table 7.	Marking description	19
Table 8.	Document revision history	20

List of figures

Figure 1.	Logic diagram	5
Figure 2.	MSOP/TSSOP-8 connections.	5
Figure 3.	Functional block diagram	8
Figure 4.	Typical hardware hookup application diagram	9
Figure 5.	\overline{MR} timing waveforms	11
Figure 6.	Voltage monitoring diagram	11
Figure 7.	TSSOP8, 3 x 3mm, package mechanical outline	16

1 Description

The STM6904 supervisor is a low voltage/low supply current processor supervisor, designed to monitor up to four system power supply voltages. This device is targeted at applications such as Set-Top Boxes (STBs), portable, battery-powered systems, networking and communication systems.

The device supports a push-button type manual reset input (\overline{MR}). Two of the four supply monitors (V_{CC} and V_{2IN}) have fixed (customer-selectable, factory-trimmed) thresholds (V_{RST1} and V_{RST2}). The other two voltage monitor inputs (V_{3IN} and V_{4IN}) are monitored using externally adjustable threshold (0.600V internal reference) to meet specific level requirements.

If any of the four monitored voltages drops below its factory-trimmed or adjustable thresholds, or if the \overline{MR} is asserted to logic low, the reset output \overline{RST} is asserted (driven low). Once asserted, \overline{RST} is maintained Low for a minimum delay period (t_{rec}) after ALL monitored supplies rise above their respective thresholds and \overline{MR} returns to High. This device is in the correct reset output logic state when V_{CC} greater than 0.8V.

The STM6904 is available in a standard 8-lead MSOP (TSSOP) package.

Figure 1. Logic diagram

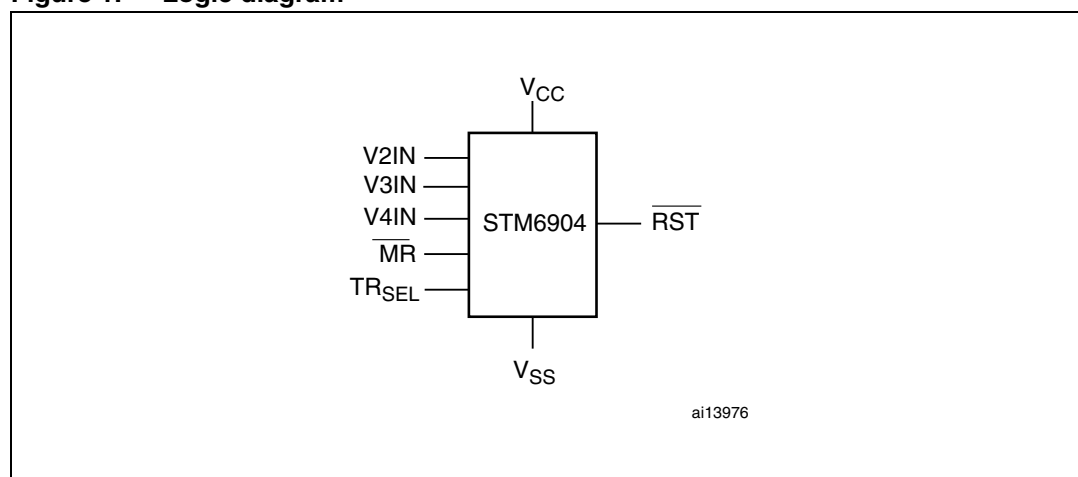

Figure 2. MSOP/TSSOP-8 connections

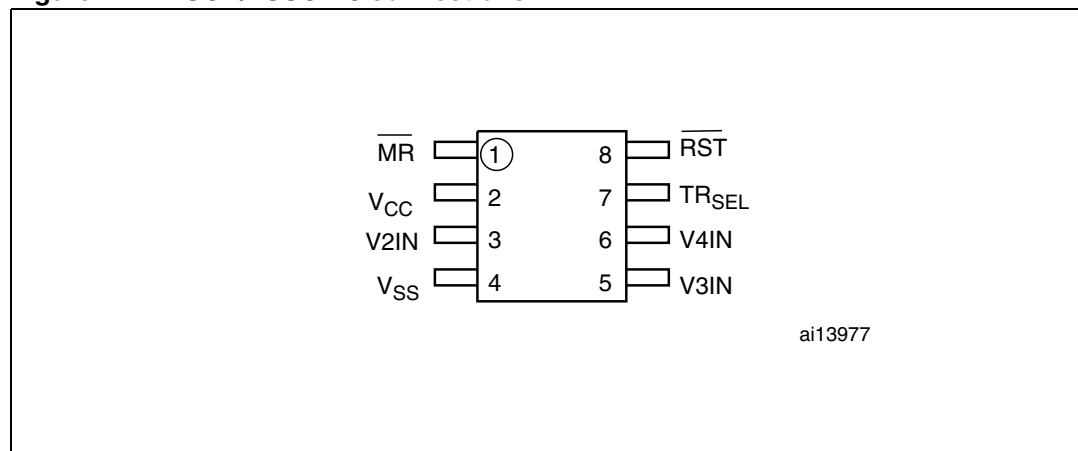

Table 2. Signal names and functions

Pin	Name	Type	Function
1	$\overline{\text{MR}}$	Input	Active-low manual reset input with internal pull-up resistor
2	V_{CC}	Supply	Primary supply voltage input and integrated fixed threshold under-voltage monitor
3	V2IN	Input	Second fixed threshold input monitor
4	V_{SS}	Supply	Ground
5	V3IN	Input	Adjustable third reset comparator input
6	V4IN	Input	Adjustable fourth reset comparator input
7	TRSEL	Input	Controls selectable t_{REC} . Two t_{REC} options available. If pin is tied HIGH (V_{CC}), $t_{\text{REC}} = 420\text{ms}$ If pin is tied LOW (V_{SS}), $t_{\text{REC}} = 210\text{ms}$ Note: Pin must be tied to V_{CC} or V_{SS} (Do not float)
8	$\overline{\text{RST}}$	Output	Active-low open-drain reset output (10k ohm internal pull-up)

2 Pin descriptions

2.1 Push-button reset input (\overline{MR})

When \overline{MR} goes low the \overline{RST} output is driven low, \overline{RST} remains low as long as \overline{MR} is low and for t_{REC} after \overline{MR} returns to high. The active-low input has an internal 10k ohm pull-up resistor to V_{CC} . It can be driven from a TTL or CMOS logic line, or with open drain/collector outputs, or connected to V_{SS} through a switch. If unused, leave this pin open or connect it to V_{CC} .

Connect a normally open momentary switch from \overline{MR} to V_{SS} ; external debounce circuitry is not required. (If \overline{MR} is driven from long cables or if the device is used in noisy environments, connecting a 0.1 uF capacitor from \overline{MR} to V_{SS} provides additional noise immunity).

2.2 V_{CC} primary supply voltage monitoring input

The V_{CC} pin is also the input for the primary reset threshold monitor. Fixed (customer-selectable, factory programmed) reset thresholds include 3.078 V to 2.866 V.

2.3 $V2IN$ second fixed voltage monitoring input

The $V2IN$ input is the second fixed-voltage input for reset threshold monitoring. Available fixed (customer-selectable, factory programmed) reset thresholds include 2.333 V to 1.050 V.

2.4 V_{SS}

This pin is the ground pin for the power supply.

2.5 $V3IN$ and $V4IN$

The $V3IN$ and $V4IN$ are high impedance inputs. \overline{RST} is driven low when the voltage (V_{TRIP}) at the pin falls below 600 mV (internal reference voltage at their respective comparators). The monitored voltage reset threshold is set with an external resistor-divider network.

2.6 \overline{RST} active-low, open drain reset output

The reset output (\overline{RST}) pin is driven low and stays low whenever V_{CC} or $V2IN$, or $V3IN$, or $V4IN$ falls below its factory-trimmed or adjustable reset threshold or when \overline{MR} goes to logic low. It remains low for t_{rec} after all supply voltages being monitored rise above their reset thresholds and \overline{MR} goes from low to high. Connect an external pull-up resistor to V_{CC} . A 10k ohms pull-up resistor should be sufficient for most applications.

2.7 TR_{SEL} input

Allows user to select between two values of t_{REC} timing (210 ms or 420 ms). Pin must be tied to V_{SS} (210 ms) or V_{CC} (420 ms).

Figure 3. Functional block diagram

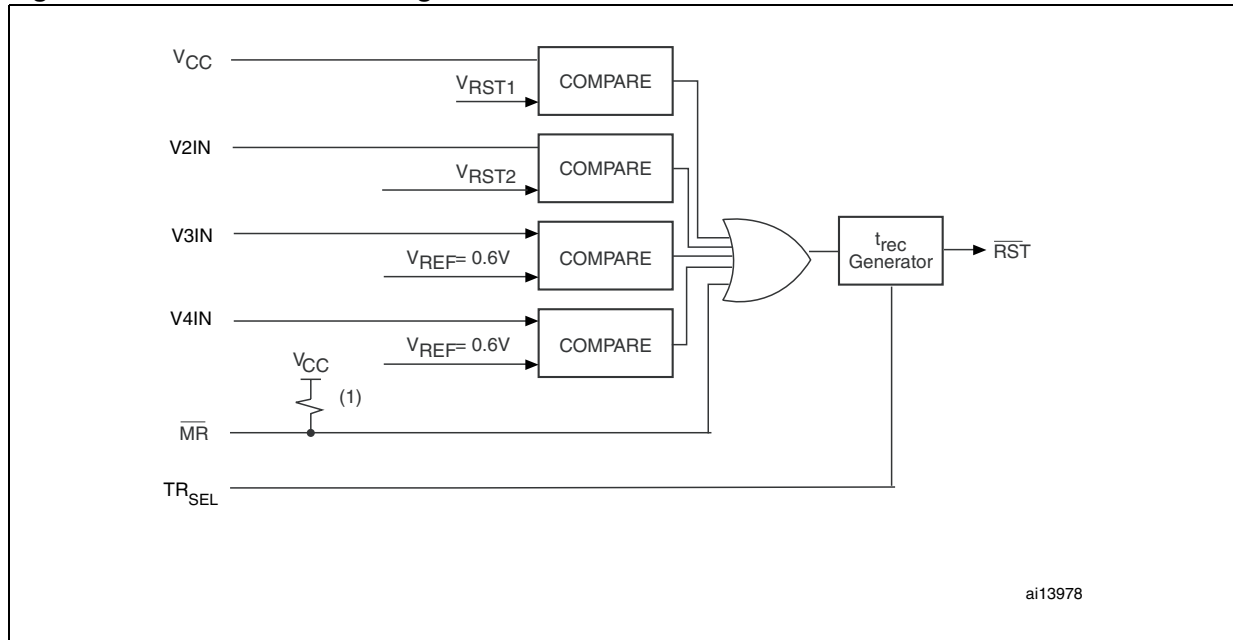

1. Internal pull-up on \overline{MR} input of 10k ohm (typ).

Figure 4. Typical hardware hookup application diagram

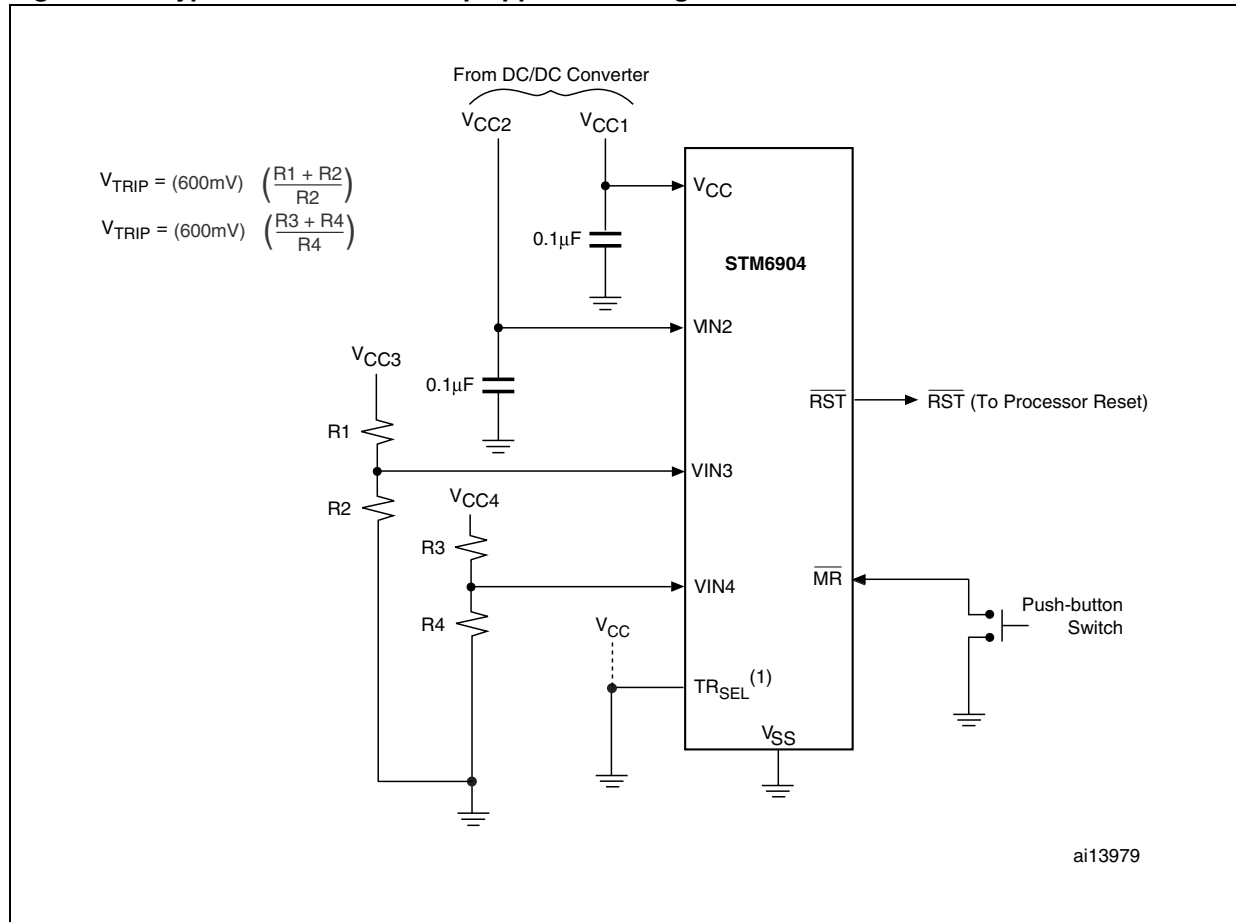

1. TRSEL must be tied to VCC (trec = 420 ms) or to VSS (trec = 210 ms).

3 Operation

The STM6904 provides the ability to monitor critical voltages such as power-supply and battery voltage levels, while interfacing easily to the system controllers/microprocessors.

Figure 4 shows typical hardware hookup for monitoring four voltages; two fixed thresholds (customer-selectable, factory-programmed) and two adjustable monitor inputs. $\overline{\text{RST}}$ output is open drain and requires a 10k ohms pull-up resistor tied to V_{CC} .

3.1 Setting the adjustable voltage levels for V3IN and V4IN inputs

The user can customize the minimum voltage levels for the two adjustable voltage inputs by connecting an external resistor divider network to the V3IN and V4IN pins in order to set the trip point at some voltage above the 600 mv (V_{REF}) according to the following formula:

$$V_{\text{TRIP}} = 0.6V \times \frac{R1 + R2}{R2}$$

During normal operation, the STM6904 monitors the voltage levels at all four pins (V_{CC} , V2IN, V3IN, and V4IN).

3.2 Power on reset (t_{REC})

On power up, the STM6904 activates a power on reset circuit which asserts the reset pin (i.e. $\overline{\text{RST}}$ goes low). The $\overline{\text{RST}}$ signal remains active until V_{CC} (and V2IN, V3IN, V4IN and $\overline{\text{MR}}$) rises above the minimum voltage level for the time period t_{REC} thereby ensuring that the supply voltage has stabilized to sufficient operating levels.

4 Voltage monitoring

Figure 5. $\overline{\text{MR}}$ timing waveforms

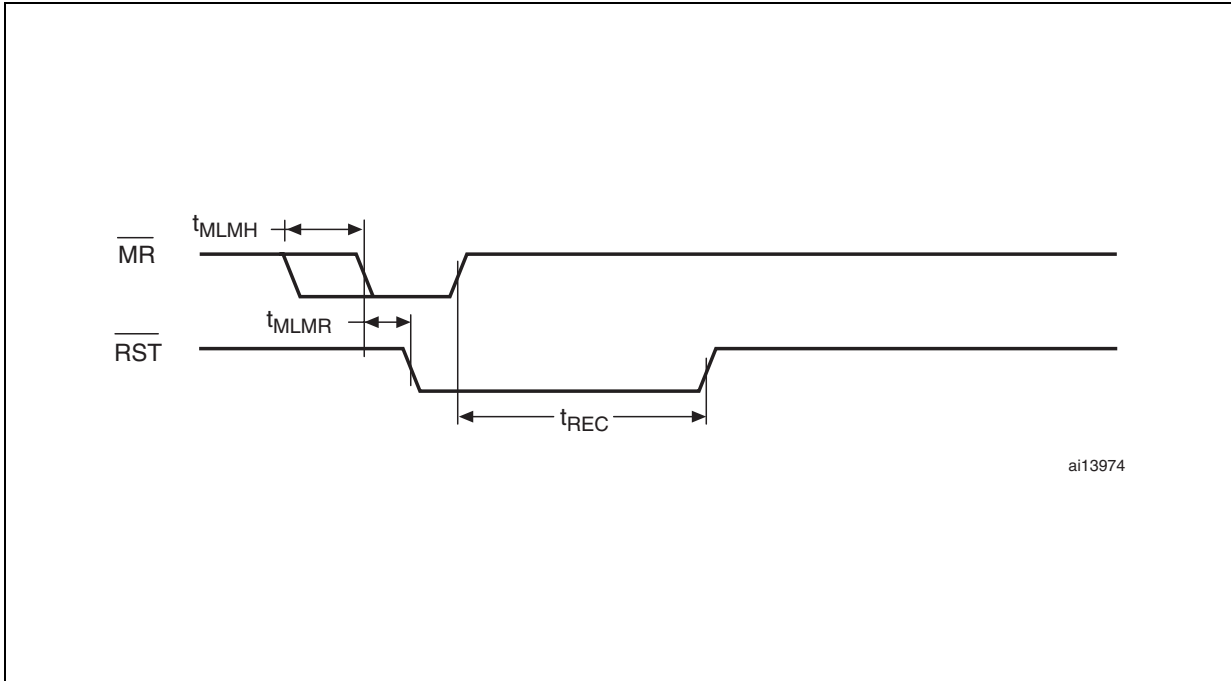
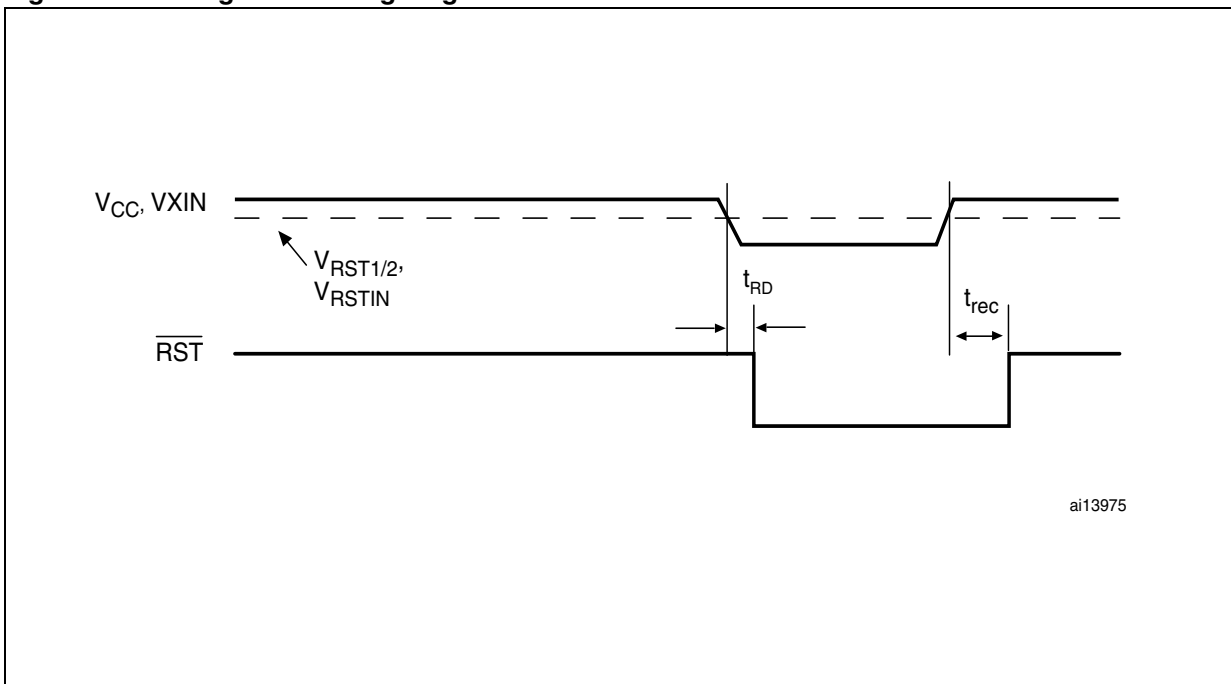

Figure 6. Voltage monitoring diagram



5 Maximum rating

Stressing the device above the rating listed in the "Absolute maximum ratings" table may cause permanent damage to the device. These are stress ratings only and operation of the device at these or any other conditions above those indicated in the Operating sections of this specification is not implied. Exposure to absolute maximum rating conditions for extended periods may affect device reliability. Refer also to the STMicroelectronics SURE Program and other relevant quality documents.

Table 3. Absolute maximum ratings

Symbol	Parameter	Value	Unit
T_{STG}	Storage temperature (V_{CC} off)	-55 to +150	°C
$T_{SLD}^{(1)}$	Lead solder temperature for 10 seconds	260	°C
V_{IO}	Input or output voltage	-0.3 to $V_{CC} + 0.3$	V
V_{CC}	Supply voltage	-0.3 to 7.0	V
I_O	Output current	20	mA
θ_{JA}	Thermal resistance (junction to ambient)	146	°C/W

1. Reflow at peak temperature of 255°C to 260°C for < 30 seconds (total thermal budget not to exceed 180°C for between 90 to 150 seconds).

6 DC and AC parameters

This section summarizes the operating measurement conditions and the DC and AC characteristics of the device. Designers should check that the operating conditions in their circuit match the operating conditions when relying on the quoted parameters.

Table 4. DC and AC characteristics

Sym	Alter-native	Description	Test condition ⁽¹⁾	Min	Typ	Max	Unit	
V_{CC}		Operating voltage		0.8		5.5	V	
I_{CC}		V_{CC} supply current	$V_{CC} < 5.5$ V		10	14	μ A	
			$V_{CC} = 3.3$ V		9	13		
I_{2IN}		V_{2IN} supply current	$V_{2IN} = 3.3$ V		3	5	μ A	
I_{LI}		Input leakage current - (\overline{MR}) ⁽²⁾	$V_{IN} = V_{SS}$		500	800	μ A	
		Input leakage current - (TR_{SEL})	$V_{IN} = V_{SS}$ or V_{CC}	-0.5		+0.5	μ A	
I_{LO} ⁽³⁾		Open drain \overline{RST} output leakage current	$V_{CC} > V_{RST}$; \overline{RST} not asserted	-0.5		+0.5	μ A	
V_{OL}		Output low voltage (\overline{RST} ; open drain)	$V_{CC} \geq 0.8$ V, $I_{SINK} = 1$ μ A			0.3	V	
			$V_{CC} \geq 1.0$ V, $I_{SINK} = 50$ μ A			0.3	V	
			$V_{CC} \geq 1.2$ V, $I_{SINK} = 100$ μ A			0.3	V	
			$V_{CC} \geq 2.7$ V, $I_{SINK} = 1.2$ mA			0.3	V	
			$V_{CC} \geq 4.5$ V, $I_{SINK} = 3.2$ mA			0.4	V	
V_{RST1} ⁽⁴⁾	V_{TH1}	V_{CC} reset threshold	T (falling)	25°C	3.047	3.078	3.109	V
				-40°C to 85°C	3.023		3.133	
			S (falling)	25°C	2.925	2.955	2.985	V
				-40°C to 85°C	2.902		3.008	
			P (falling)	25°C	2.837	2.866	2.895	V
				-40°C to 85°C	2.814		2.918	

Table 4. DC and AC characteristics (continued)

Sym	Alternative	Description	Test condition ⁽¹⁾	Min	Typ	Max	Unit	
V _{RST2} ⁽⁴⁾	V _{TH2}	V2IN reset threshold	Z (falling)	25°C	2.310	2.333	2.356	V
				-40°C to 85°C	2.291		2.375	
			Y (falling)	25°C	2.166	2.188	2.210	V
				-40°C to 85°C	2.149		2.227	
			W (falling)	25°C	1.666	1.683	1.700	V
				-40°C to 85°C	1.653		1.713	
			G (falling)	25°C	1.099	1.110	1.121	V
				-40°C to 85°C	1.090		1.130	
F (falling)	25°C	1.040	1.050	1.061	V			
	-40°C to 85°C	1.031		1.069				
V _{HYST}		Reset threshold hysteresis	Referenced to V _{RST1} /V _{RST2} typical		0.5		%	
t _{RD}		V _{CC} to $\overline{\text{RST}}$ delay	V _{CC} = (V _{RST1} + 100 mV) to (V _{RST1} - 100 mV)		20		μs	
			V2IN = (V _{RST2} + 75 mV) to (V _{RST2} - 75 mV)		20		μs	
t _{REC} ⁽⁵⁾	t _{RP}	$\overline{\text{RST}}$ time-out period	TR _{SEL} = LOW (V _{SS})	140	210	280	ms	
			TR _{SEL} = HIGH (V _{CC})	280	420	560	ms	
Adjustable reset comparator input (V3IN and V4IN)								
VRSTIN		V3IN, V4IN input threshold		589	600	611	mV	
I3IN, I4IN		V3IN, V4IN input current	V3IN, V4IN > 0.8 V	-25		+25	nA	
		V3IN, V4IN hysteresis			3		mV	
t _{RSTIND}		V3IN, V4IN to $\overline{\text{RST}}$ output delay	VRSTIN to (VRSTIN - 30 mV)		22		μs	
Manual (push-button) reset input								
V _{IL}		$\overline{\text{MR}}$ input voltage				0.3 x V _{CC}	V	
V _{IH}					0.7 x V _{CC}			V
t _{MLMH}	t _{MR}	$\overline{\text{MR}}$ minimum pulse width		1			μs	
t _{MLRL}	t _{MRD}	$\overline{\text{MR}}$ to $\overline{\text{RST}}$ output delay			200		ns	

Table 4. DC and AC characteristics (continued)

Sym	Alter-native	Description	Test condition ⁽¹⁾	Min	Typ	Max	Unit
		\overline{MR} glitch immunity			100		ns
		\overline{MR} pull-up resistance			10		k Ω

1. Valid for ambient operating temperature: $T_A = -40^\circ\text{C}$ to $+85^\circ\text{C}$; $V_{CC} = 0.8\text{V}$ to 5.5V (except where noted).
2. 10k ohm (typ) internal pull-up resistor.
3. The leakage current measured on the \overline{RST} pin is tested with the reset de-asserted (output high impedance).
4. Other reset threshold voltages are offered. Minimum order quantities may apply. Contact local sales office for availability.
5. Other t_{REC} time-out periods are offered. Minimum order quantities may apply. Contact local sales office for availability.

7 Package mechanical data

In order to meet environmental requirements, ST offers these devices in ECOPACK[®] packages. These packages have a lead-free second level interconnect. The category of second level interconnect is marked on the package and on the inner box label, in compliance with JEDEC Standard JESD97. The maximum ratings related to soldering conditions are also marked on the inner box label. ECOPACK is an ST trademark. ECOPACK specifications are available at: www.st.com.

Figure 7. TSSOP8, 3 x 3mm, package mechanical outline

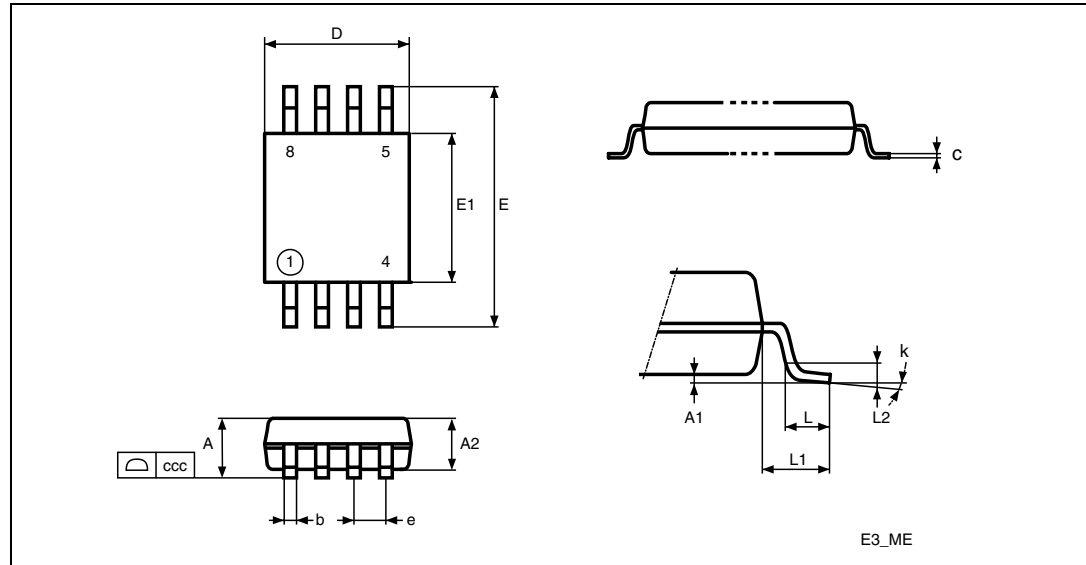

Table 5. TSSOP 8-lead package mechanical data

Symbol	mm			inches		
	Min	Typ	Max	Min	Typ	Max
A			1.10			0.043
A1	0.00		0.15	0.000		0.006
A2	0.75	0.85	0.95	0.030	0.034	0.037
b	0.22		0.40	0.009		0.016
c	0.08		0.23	0.003		0.009
ccc			0.10			0.004
D	2.80	3.00	3.20	0.110	0.118	0.126
e		0.65			0.026	
E	4.65	4.90	5.15	0.183	0.193	0.203
E1	2.80	3.00	3.10	0.110	0.118	0.122
L	0.40	0.60	0.80	0.016	0.024	0.032
L1		0.95			0.037	
L2		0.25			0.010	
k	0°	4	6°	0°	4	6°
N	8			8		

8 Part numbering

Table 6. Ordering information scheme

Example:	STM6904	TZ	E	DS	6	F
Device type						
STM6904						
Reset threshold voltages⁽¹⁾						
Suffix	V_{RST1}	V_{RST2}				
TZ	3.078	2.333				
TW	3.078	1.683				
TG	3.078	1.110				
SY	2.955	2.188				
SF	2.955	1.050				
PW	2.866	1.683				
t_{REC}⁽¹⁾						
E = 210ms or 420ms						
Package						
DS = MSOP8 (TSSOP8)						
Temperature range						
6: -40°C to 85°C						
Shipping method						
E = ECOPACK® package, tubes						
F = ECOPACK® package, tape & reel						

1. Other reset threshold voltages and t_{REC} time-out periods are offered. Minimum order quantities may apply. Contact local sales office for availability.

9 Package marking information

Table 7. Marking description

Part marking	V _{RST1} (V)	V _{RST2} (V)	Package	Topside marking
STM6904TZEDS6F	3.078	2.333	MSOP (TSSOP8)	STZ4
STM6904TWEDS6F	3.078	1.683	MSOP (TSSOP8)	STW4
STM6904TGEDS6F	3.078	1.110	MSOP (TSSOP8)	STG4
STM6904SFEDS6F	2.955	1.050	MSOP (TSSOP8)	SSF4
STM6904SYEDS6F	2.955	2.188	MSOP (TSSOP8)	SSY4
STM6904PWEDS6F	2.866	1.683	MSOP (TSSOP8)	SPW4

10 Revision history

Table 8. Document revision history

Date	Revision	Changes
19-Dec-2007	1	Initial release.
28-Jan-2008	2	Updated cover page, Figure 6 and Table 4 .

Please Read Carefully:

Information in this document is provided solely in connection with ST products. STMicroelectronics NV and its subsidiaries ("ST") reserve the right to make changes, corrections, modifications or improvements, to this document, and the products and services described herein at any time, without notice.

All ST products are sold pursuant to ST's terms and conditions of sale.

Purchasers are solely responsible for the choice, selection and use of the ST products and services described herein, and ST assumes no liability whatsoever relating to the choice, selection or use of the ST products and services described herein.

No license, express or implied, by estoppel or otherwise, to any intellectual property rights is granted under this document. If any part of this document refers to any third party products or services it shall not be deemed a license grant by ST for the use of such third party products or services, or any intellectual property contained therein or considered as a warranty covering the use in any manner whatsoever of such third party products or services or any intellectual property contained therein.

UNLESS OTHERWISE SET FORTH IN ST'S TERMS AND CONDITIONS OF SALE ST DISCLAIMS ANY EXPRESS OR IMPLIED WARRANTY WITH RESPECT TO THE USE AND/OR SALE OF ST PRODUCTS INCLUDING WITHOUT LIMITATION IMPLIED WARRANTIES OF MERCHANTABILITY, FITNESS FOR A PARTICULAR PURPOSE (AND THEIR EQUIVALENTS UNDER THE LAWS OF ANY JURISDICTION), OR INFRINGEMENT OF ANY PATENT, COPYRIGHT OR OTHER INTELLECTUAL PROPERTY RIGHT.

UNLESS EXPRESSLY APPROVED IN WRITING BY AN AUTHORIZED ST REPRESENTATIVE, ST PRODUCTS ARE NOT RECOMMENDED, AUTHORIZED OR WARRANTED FOR USE IN MILITARY, AIR CRAFT, SPACE, LIFE SAVING, OR LIFE SUSTAINING APPLICATIONS, NOR IN PRODUCTS OR SYSTEMS WHERE FAILURE OR MALFUNCTION MAY RESULT IN PERSONAL INJURY, DEATH, OR SEVERE PROPERTY OR ENVIRONMENTAL DAMAGE. ST PRODUCTS WHICH ARE NOT SPECIFIED AS "AUTOMOTIVE GRADE" MAY ONLY BE USED IN AUTOMOTIVE APPLICATIONS AT USER'S OWN RISK.

Resale of ST products with provisions different from the statements and/or technical features set forth in this document shall immediately void any warranty granted by ST for the ST product or service described herein and shall not create or extend in any manner whatsoever, any liability of ST.

ST and the ST logo are trademarks or registered trademarks of ST in various countries.

Information in this document supersedes and replaces all information previously supplied.

The ST logo is a registered trademark of STMicroelectronics. All other names are the property of their respective owners.

© 2008 STMicroelectronics - All rights reserved

STMicroelectronics group of companies

Australia - Belgium - Brazil - Canada - China - Czech Republic - Finland - France - Germany - Hong Kong - India - Israel - Italy - Japan - Malaysia - Malta - Morocco - Singapore - Spain - Sweden - Switzerland - United Kingdom - United States of America

www.st.com