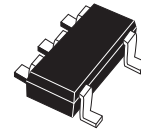

Ultra-low current 2.4V precision analog temperature sensor

Features

- Precision analog voltage output temperature sensor
- $\pm 1.5^{\circ}\text{C}$ temperature accuracy at 25°C
- Ultra-low quiescent supply current: $8.0\mu\text{A}$ (max)
- Operating voltage range: 2.4V to 5.5V
- Operating temperature range:
 - 55°C to 130°C (grade - 7)
 - 40°C to 85°C (grade - 9)
- SOT323-5 (SC70-5) 5-lead package
- UDFN 4-lead package

Applications

- Third generation (3G) cell phones
- Multimedia PDA devices
- GPS devices
- Portable medical instruments
- Voltage-controlled crystal oscillator temperature monitors
- RF power transistor monitor



SOT323-5, SC70-5 (W8)

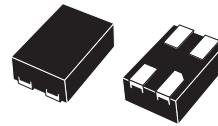

UDFN 4-lead (DD)

Contents

1	Description	5
2	Transfer function	6
3	Maximum rating	8
4	DC and AC characteristics	9
5	Capacitive load	10
6	Typical operating characteristics	11
7	Package mechanical data	12
8	Part numbering	14
9	Revision history	15

List of tables

Table 1.	Signal names	5
Table 2.	First order equations optimized for different temperature ranges	6
Table 3.	Quadratic output equation ($V_{CC} = 2.7V$)	7
Table 4.	Quadratic output equation for operations over the full voltage range ($V_{CC} = 2.4V$ to $5.5V$)	7
Table 5.	Absolute maximum ratings	8
Table 6.	DC and AC characteristics	9
Table 7.	Resistor/capacitor combinations for the filter network	10
Table 8.	SOT323-5 – 5-lead small outline transistor package mechanical data	12
Table 9.	UDFN – 4-lead package mechanical data	13
Table 10.	Ordering information scheme	14
Table 11.	Marking description	14
Table 12.	Revision history	15

List of figures

Figure 1.	Logic diagram	5
Figure 2.	Connections (top view)	5
Figure 3.	Filter network for noisy environments or capacitive loads > 300pF	10
Figure 4.	V_{OUT} vs. Temperature	11
Figure 5.	SOT323-5 – 5-lead small outline transistor package outline	12
Figure 6.	UDFN – 4-lead package outline	13

1 Description

The STLM20 is a precision analog output temperature sensor for low current applications where maximizing battery life is important. It operates over a -55°C to 130°C (grade 7) or -40°C to 85°C (grade 9) temperature range. The power supply operating range is 2.4V to 5.5V. The accuracy of the STLM20 is $\pm 1.5^{\circ}\text{C}$, at an ambient temperature of 25°C . The temperature error increases linearly and reaches a maximum of $\pm 2.5^{\circ}\text{C}$ at the temperature range extremes. The temperature range is affected by the power supply voltage. For the temperature grade 7 device, a power supply voltage of 2.7V to 5.5V, the temperature range extremes are $+130^{\circ}\text{C}$ and -55°C . Decreasing the power supply voltage to 2.4V changes the negative extreme to -30°C , while the positive remains at $+130^{\circ}\text{C}$.

The STLM20 has a maximum quiescent supply current of $8\mu\text{A}$. Therefore, self-heating is negligible.

Figure 1. Logic diagram

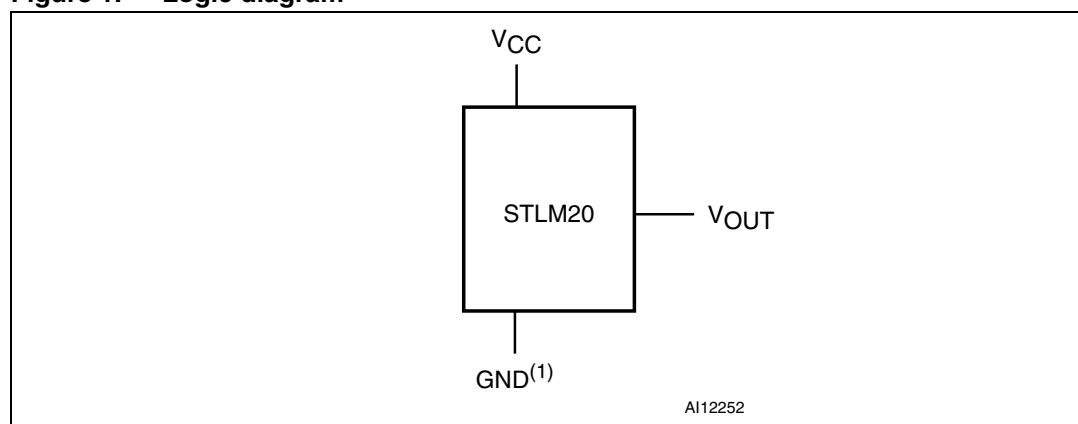

1. Pin 2 GND may be grounded or left floating (SC70-5 only). For optimum thermal conductivity to the PC board ground plane, it should be grounded.

Table 1. Signal names

V_{CC}	Supply voltage
GND	Ground
V_{OUT}	Output voltage
NC	No connect

Figure 2. Connections (top view)

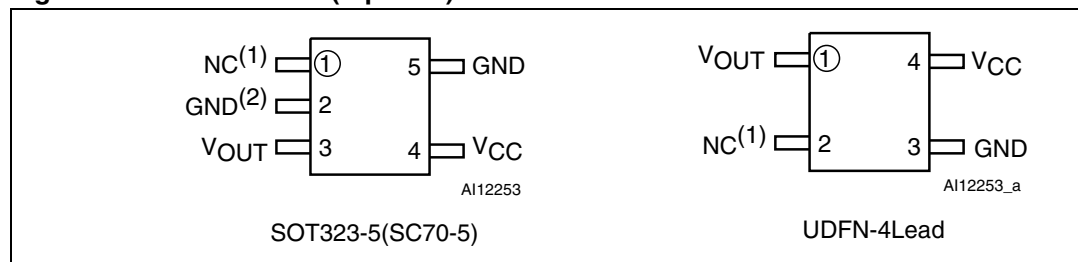

1. Pin 1 NC should be left floating or grounded.
2. Pin 2 GND may be grounded or left floating. For optimum thermal conductivity to the PC board ground plane, it should be grounded.

2 Transfer function

The STLM20's transfer function can be described in different ways, with varying levels of precision. A simple linear transfer function, with good accuracy near 25°C is expressed as:

Equation 1

$$V_O = (-11.69\text{mV}/^\circ\text{C}) \times T + 1.8663\text{V}$$

Over the specified operating temperature range, the best accuracy can be obtained by using the parabolic transfer function:

Equation 2

$$V_O = (-3.88 \times 10^{-6} \times T^2) + (-1.15 \times 10^{-2} \times T) + 1.8639$$

and solving for T:

Equation 3

$$T = -1481.96 + \sqrt{2.1962 \times 10^6 + \frac{(1.8639 - V_O)}{3.88 \times 10^{-6}}}$$

The best fit linear transfer function for many popular temperature ranges was calculated in [Table 2](#), where the error introduced by the linear transfer function increases with wider temperature ranges.

Table 2. First order equations optimized for different temperature ranges

Temperature range		Linear equation $V_O =$	Maximum deviation of linear equation from parabolic equation (°C)
T_{\min} (°C)	T_{\max} (°C)		
-55	130	$-11.79\text{mV}/^\circ\text{C} * T + 1.8528\text{V}$	± 1.41
-40	110	$-11.77\text{mV}/^\circ\text{C} * T + 1.8577\text{V}$	± 0.93
-30	100	$-11.77\text{mV}/^\circ\text{C} * T + 1.8605\text{V}$	± 0.70
-40	85	$-11.67\text{mV}/^\circ\text{C} * T + 1.8583\text{V}$	± 0.65
-10	65	$-11.71\text{mV}/^\circ\text{C} * T + 1.8641\text{V}$	± 0.23
35	45	$-11.81\text{mV}/^\circ\text{C} * T + 1.8701\text{V}$	± 0.004
20	30	$-11.69\text{mV}/^\circ\text{C} * T + 1.8663\text{V}$	± 0.004

Table 3. Quadratic output equation ($V_{CC} = 2.7V$)

Parameter	Conditions	Min	Typ	Max	Unit
Temperature error based on: $V_{OUT} = (-3.88e^{-6} \times T^2) + (-1.15e^{-2} \times T) + 1.8639$ where T is the temperature	$T_A = -55^\circ C$	2.457	2.485	2.512	V
	$T_A = -40^\circ C$	2.292	2.318	2.343	
	$T_A = -30^\circ C$	2.181	2.205	2.230	
	$T_A = -20^\circ C$	2.069	2.092	2.116	
	$T_A = 0^\circ C$	1.842	1.864	1.886	
	$T_A = 25^\circ C$	1.556	1.574	1.592	
	$T_A = 50^\circ C$	1.255	1.279	1.303	
	$T_A = 85^\circ C$	0.833	0.859	0.884	
	$T_A = 130^\circ C$	0.272	0.303	0.335	

Table 4. Quadratic output equation for operations over the full voltage range ($V_{CC} = 2.4V$ to $5.5V$)

Parameter ⁽¹⁾	Conditions	Min	Max	Unit
Temperature error based on: $V_{OUT} = (-3.88e^{-6} \times T^2) + (-1.15e^{-2} \times T) + 1.8639$, where T is the temperature	$T_A = -55^\circ C^{(2) (3)}$	2.457	2.531	V
	$T_A = -40^\circ C^{(2)}$	2.292	2.362	
	$T_A = -30^\circ C$	2.180	2.249	
	$T_A = -20^\circ C$	2.068	2.135	
	$T_A = 0^\circ C$	1.841	1.904	
	$T_A = 25^\circ C$	1.555	1.610	
	$T_A = 50^\circ C$	1.254	1.322	
	$T_A = 85^\circ C$	0.832	0.903	
	$T_A = 130^\circ C^{(3)}$	0.271	0.353	

- V_{OUT} tolerance is $\pm 4\%$ (temperature grade 9 only).
- Valid for V_{CC} min = 2.7V.
- Valid for temperature grade 7 only.

3 Maximum rating

Stressing the device above the rating listed in the Absolute Maximum Ratings” table may cause permanent damage to the device. These are stress ratings only and operation of the device at these or any other conditions above those indicated in the Operating sections of this specification is not implied. Exposure to Absolute Maximum Rating conditions for extended periods may affect device reliability. Refer also to the STMicroelectronics SURE Program and other relevant quality documents.

Table 5. Absolute maximum ratings

Symbol	Parameter		Value	Unit
T_{STG}	Storage temperature		-65 to +150	°C
$T_{SLD}^{(1)}$	Lead solder temperature for 10 seconds		260	°C
V_O	Output voltage		-0.6 to $V_{CC} + 0.6$	V
V_{CC}	Supply voltage		-0.2 to 6.5	V
I_O	Output current		10	mA
$T_{J(max)}$	Maximum junction temperature		150	°C
θ_{JA}	Thermal resistance	SOT323-5 (SC70-5)	331.4	°C/W
		UDFN	160.2	°C/W
$T_A^{(2)}$	Ambient operating temperature	Grade 7	-55 to 130	°C
		Grade 9	-40 to 85	°C

1. Reflow at peak temperature of 255°C to 260°C for < 30 seconds (total thermal budget not to exceed 180°C for between 90 to 150 seconds).
2. Grade 7: STLM20W87F
Grade 9: STLM20DD9F

4 DC and AC characteristics

This section summarizes the DC and AC characteristics of the device. The parameters in the DC and AC characteristics table that follows are derived from tests performed under the test conditions (see [Table 6 on page 9](#)). Designers should check that the operating conditions in their circuit match the operating conditions when relying on the quoted parameters.

Table 6. DC and AC characteristics

Sym	Description	Test condition ⁽¹⁾	Min	Typ ⁽²⁾	Max	Unit
V _{CC}	Supply voltage	T _A = -30°C to 130°C	2.4		5.5	V
		T _A = -55°C to 130°C or -40°C to 85°C	2.7		5.5	V
V _O	Output voltage	T _A = 0°C		1.8639		V
	Temperature to voltage error ⁽³⁾ V _O = (-3.88E-6 * T ²) + (-1.15E-2 * T) + 1.8639V	T _A = 25°C to 30°C			±1.5	°C
		T _A = 125°C to 130°C			±2.5	°C
		T _A = 80°C to 85°C			±2.1	°C
		T _A = 0°C			±1.9	°C
		T _A = -40°C			±2.3	°C
		T _A = -55°C			±2.5	°C
I _Q	Quiescent current	2.4V ≤ V _{CC} ≤ 5.5V		4.8	8	μA
	Sensor gain (temperature sensitivity or average slope), V _O = -11.77mV/°C * T + 1.860V	-30°C ≤ T _A ≤ 100°C	-11.4	-11.77	-12.2	mV/°C
	Non-linearity	-20°C ≤ T _A ≤ 80°C		±0.4		%
ΔI _Q	Change of quiescent current	2.4V ≤ V _{CC} ≤ 5.5V		0.7		μA
T _C V _O	Temperature coefficient of quiescent current			-11		nA/°C
I _{SD}	Shutdown current	V _{CC} ≤ 0.8V		0.02		μA
Z _O	Output impedance	0μA ≤ I _L ≤ 16μA ⁽⁴⁾⁽⁵⁾			160	Ω
RegL	Load regulation ⁽⁶⁾				-2.5	mV
Reg1	Line regulation	2.4V ≤ V _{CC} ≤ 5.0V			3.3	mV/V
Reg2		5.0V ≤ V _{CC} ≤ 5.5V			11	mV

1. Valid for ambient operating temperature: T_A = -55 to 130°C or T_A = -40 to 85°C; V_{CC} = 2.7V (except where noted).

2. T_J = T_A = 25°C.

3. Error accuracy is between the measured and calculated output voltage at specified conditions of voltage, current, and temperature.

4. With negative current flowing into STLM20 and positive current flowing out, can typically sink less than 1μA and source is 16μA.

5. Over the supply range of 2.4 to 5.5V.

6. Measured at constant junction temperature, with pulse testing and low duty cycle. Output changes due to heating may be calculated by multiplying internal dissipation by thermal resistance.

5 Capacitive load

The STLM20 will handle capacitive loads of up to 300pF. Over the specified temperature range, the STLM20 has a maximum output impedance of 160Ω.

In a noisy environment, it may be advisable to add some filtering to minimize noise in the output voltage. A 0.1μF capacitor added between the supply voltage and ground is recommended.

In an extremely noisy environment, it may be necessary to add a low-pass filter network to the output of the device. A 1μF capacitor, in addition to the output impedance of the device, and a 200Ω series resistor, will provide a low-pass filter that will pass the slow thermal time constant of the STLM20, while filtering the higher frequency noise.

Figure 3. Filter network for noisy environments or capacitive loads > 300pF

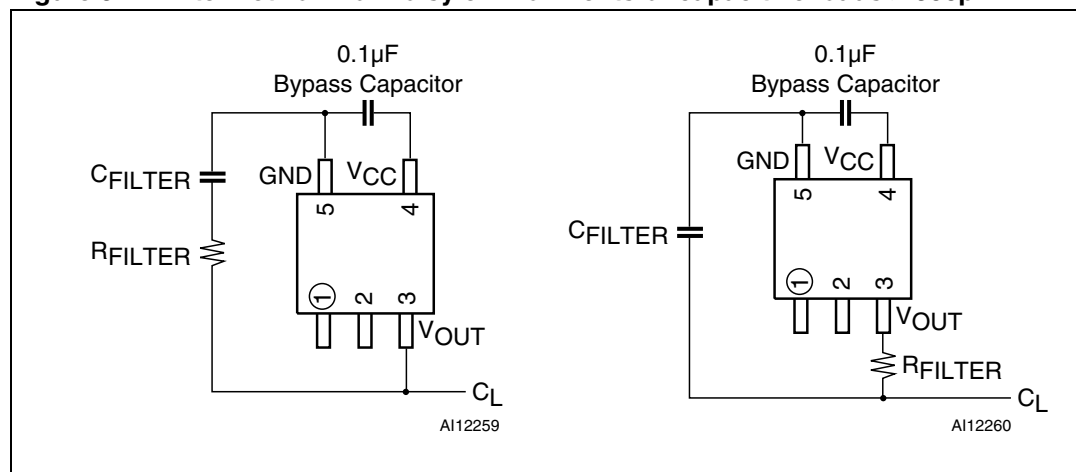

Table 7. Resistor/capacitor combinations for the filter network

R_{FILTER}	C_{FILTER}
200Ω	1μF
470Ω	0.1μF
680Ω	0.01μF
1000Ω	1000pF
10kΩ	100pF
100kΩ	10pF

6 Typical operating characteristics

The graph shown in [Figure 6](#) represents V_{OUT} according to temperature.

Figure 4. V_{OUT} vs. Temperature

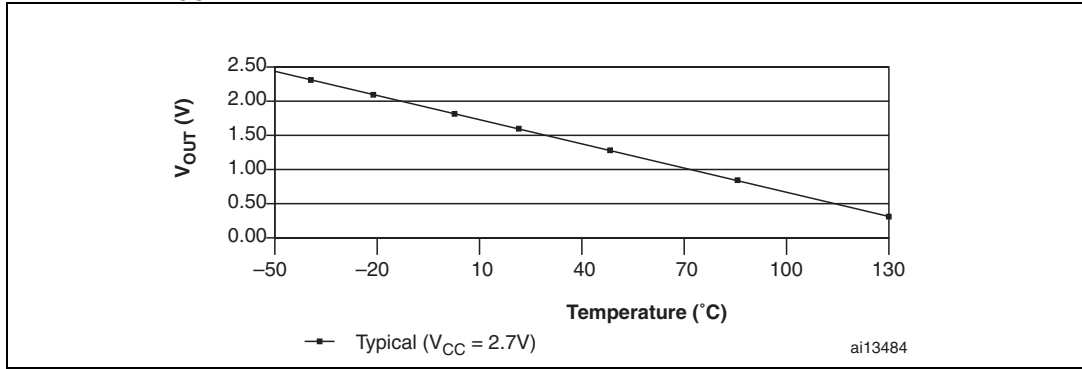

7 Package mechanical data

In order to meet environmental requirements, ST offers these devices in ECOPACK[®] packages. These packages have a lead-free second level interconnect. The category of second Level Interconnect is marked on the package and on the inner box label, in compliance with JEDEC Standard JESD97. The maximum ratings related to soldering conditions are also marked on the inner box label. ECOPACK is an ST trademark. ECOPACK specifications are available at: www.st.com.

Figure 5. SOT323-5 – 5-lead small outline transistor package outline

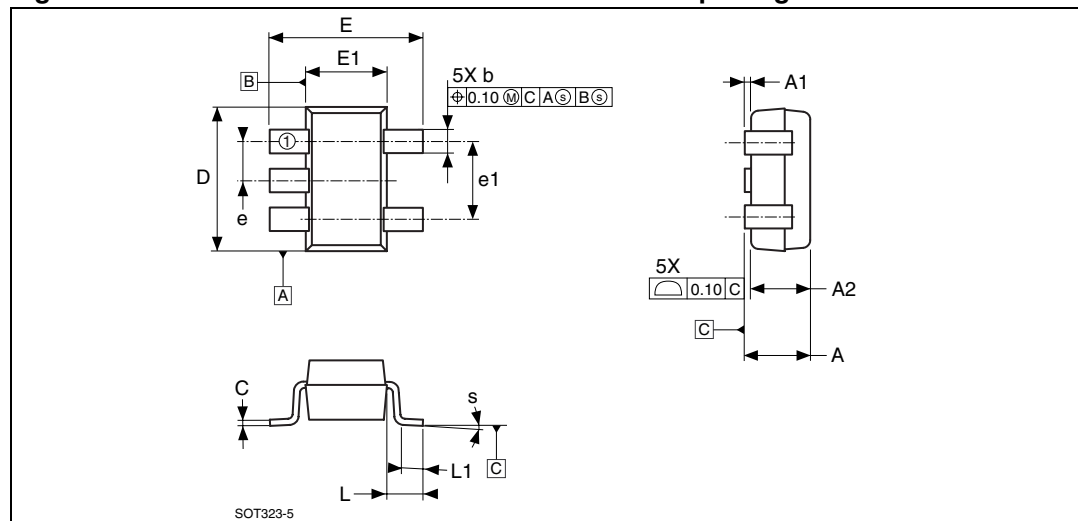

1. Drawing is not to scale.

Table 8. SOT323-5 – 5-lead small outline transistor package mechanical data

Symbol	mm			inches		
	Typ	Min	Max	Typ	Min	Max
A	–	0.80	1.10	–	0.031	0.043
A1	–	0	0.10	–	0	0.004
A2	0.90	–	–	0.035	–	–
b	–	0.15	0.30	–	0.006	0.012
C	–	0.10	0.20	–	0.004	0.008
D	2.00	1.90	2.10	0.079	0.075	0.083
E	–	1.80	2.40	–	0.071	0.094
E1	1.25	1.15	1.35	0.049	0.045	0.053
e	0.65	–	–	0.026	–	–
e1	1.30	–	–	0.051	–	–
L	0.52	–	–	0.020	–	–
L1	0.40	0.35	0.45	0.016	0.014	0.018
s	–	0°	5°	–	0°	5°

Figure 6. UDFN – 4-lead package outline

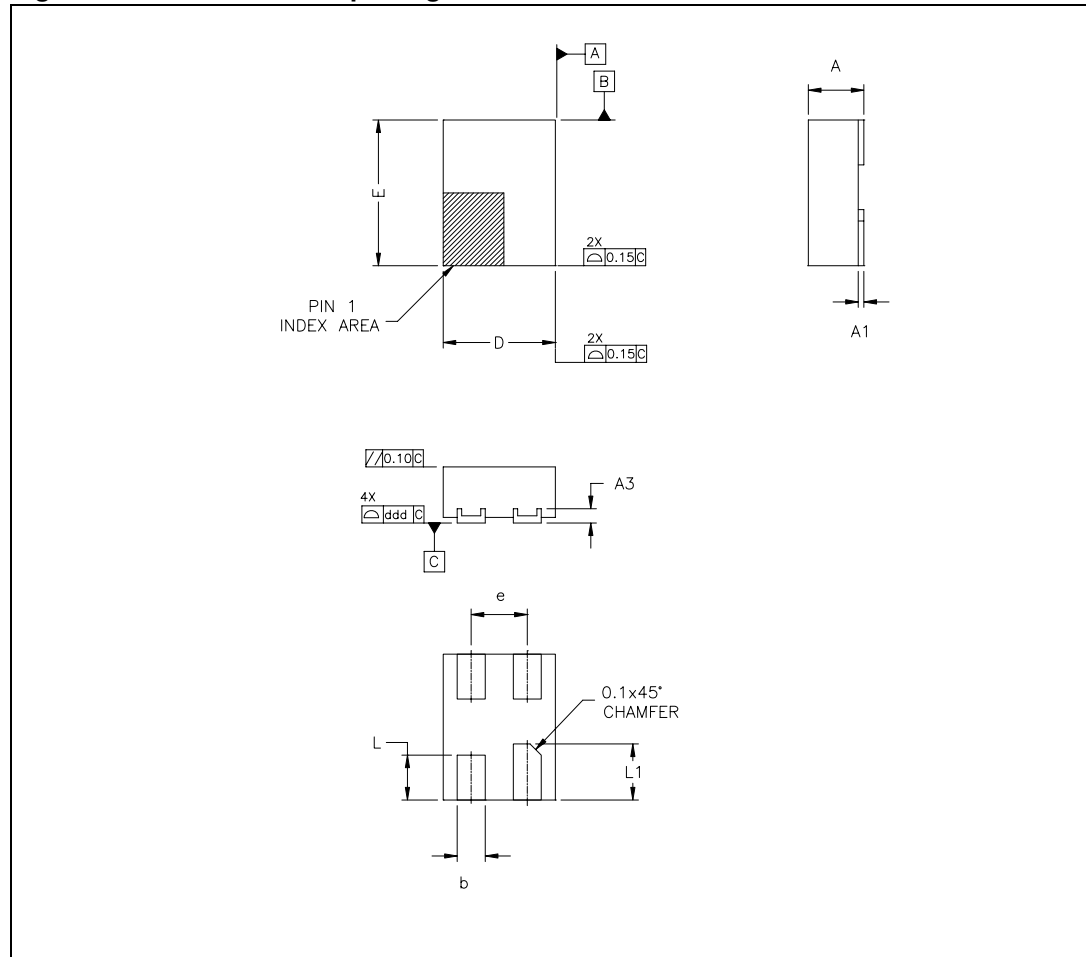

1. Drawing is not to scale.

Table 9. UDFN – 4-lead package mechanical data

Symbol	mm			inches		
	Min	Typ	Max	Min	Typ	Max
A	0.45	0.50	0.55	0.018	0.020	0.022
A1	0	0.025	0.05	0	0.001	0.002
A3	0.119	0.127	0.177	0.0046	0.0050	0.0069
b	0.20	0.25	0.30	0.008	0.010	0.012
D	0.95	1.00	1.05	0.037	0.039	0.041
E	1.25	1.30	1.35	0.049	0.051	0.053
e	0.45	0.50	0.55	0.018	0.020	0.022
L	0.35	0.40	0.45	0.014	0.016	0.018
L1	0.45	0.50	0.55	0.018	0.020	0.022
ddd	0	0.04	0.08	0	0.0016	0.0031

8 Part numbering

Table 10. Ordering information scheme

Example:	STLM20	DD	9	F
Device type				
STLM20				
Package				
W8 = SOT323-5 (SC70-5) ⁽¹⁾				
DD= UDFN - ultra thin DFN 4-lead ⁽²⁾				
Temperature range				
7 = -55 to 130°C				
9 = -40 to 85°C				
Shipping method				
F = ECOPACK® package, tape & reel				
1. Available in temperature grade 7 (-55 to 130°C) only.				
2. Available in temperature grade 9 (-40 to 85°C) only.				

Table 11. Marking description

Part number	Package	Marking
STLM20W8	SOT323-5(SC70-5)	M20
STLM20DD	UDFN	20

For other options, or for more information on any aspect of this device, please contact the ST sales office nearest you.

9 Revision history

Table 12. Revision history

Date	Revision	Changes
28-Jun-2006	1	Initial release.
19-Jul-2006	2	Added Table 11: Marking description
28-Aug-2006	3	Added a footnote concerning package availability in Features on page 1 and to Table 10 and Table 11 ; updated package mechanical data in Table 9
05-Sep-2006	4	Amended text in the Features on page 1, Section 1: Description, Section 2: Transfer function, Table 6, and Table 10 to elucidate that two packages exist each with specific temperature ranges: SOT323-5 (SC70-5) 5-lead package (–55 to 130°C) and UDFN 4-lead package (–40 to 85°C)
25-Sep-2006	5	Updated Operating Temperature Ranges (now 7 and 9); updated Table 6: DC and AC characteristics
10-Oct-2006	6	Table 3: Quadratic output equation ($V_{CC} = 2.7V$) and Table 4: Quadratic output equation for operations over the full voltage range ($V_{CC} = 2.4V$ to $5.5V$) added. Section 6: Typical operating characteristics added. T_A added to Table 5: Absolute maximum ratings .
04-Dec-2006	7	Document status updated to full datasheet; updated text in the title of Table 4: Quadratic output equation for operations over the full voltage range ($V_{CC} = 2.4V$ to $5.5V$) ; added footnotes regarding temperature ranges in Table 10: Ordering information scheme .
08-Feb-2007	8	Added thermal resistance in Table 5: Absolute maximum ratings .
09-May-2007	9	Modified Equation 1, 2, and 3 .
26-Nov-2007	10	Updated footnote 2 in Table 5 ; minor text updates.

Please Read Carefully:

Information in this document is provided solely in connection with ST products. STMicroelectronics NV and its subsidiaries ("ST") reserve the right to make changes, corrections, modifications or improvements, to this document, and the products and services described herein at any time, without notice.

All ST products are sold pursuant to ST's terms and conditions of sale.

Purchasers are solely responsible for the choice, selection and use of the ST products and services described herein, and ST assumes no liability whatsoever relating to the choice, selection or use of the ST products and services described herein.

No license, express or implied, by estoppel or otherwise, to any intellectual property rights is granted under this document. If any part of this document refers to any third party products or services it shall not be deemed a license grant by ST for the use of such third party products or services, or any intellectual property contained therein or considered as a warranty covering the use in any manner whatsoever of such third party products or services or any intellectual property contained therein.

UNLESS OTHERWISE SET FORTH IN ST'S TERMS AND CONDITIONS OF SALE ST DISCLAIMS ANY EXPRESS OR IMPLIED WARRANTY WITH RESPECT TO THE USE AND/OR SALE OF ST PRODUCTS INCLUDING WITHOUT LIMITATION IMPLIED WARRANTIES OF MERCHANTABILITY, FITNESS FOR A PARTICULAR PURPOSE (AND THEIR EQUIVALENTS UNDER THE LAWS OF ANY JURISDICTION), OR INFRINGEMENT OF ANY PATENT, COPYRIGHT OR OTHER INTELLECTUAL PROPERTY RIGHT.

UNLESS EXPRESSLY APPROVED IN WRITING BY AN AUTHORIZED ST REPRESENTATIVE, ST PRODUCTS ARE NOT RECOMMENDED, AUTHORIZED OR WARRANTED FOR USE IN MILITARY, AIR CRAFT, SPACE, LIFE SAVING, OR LIFE SUSTAINING APPLICATIONS, NOR IN PRODUCTS OR SYSTEMS WHERE FAILURE OR MALFUNCTION MAY RESULT IN PERSONAL INJURY, DEATH, OR SEVERE PROPERTY OR ENVIRONMENTAL DAMAGE. ST PRODUCTS WHICH ARE NOT SPECIFIED AS "AUTOMOTIVE GRADE" MAY ONLY BE USED IN AUTOMOTIVE APPLICATIONS AT USER'S OWN RISK.

Resale of ST products with provisions different from the statements and/or technical features set forth in this document shall immediately void any warranty granted by ST for the ST product or service described herein and shall not create or extend in any manner whatsoever, any liability of ST.

ST and the ST logo are trademarks or registered trademarks of ST in various countries.

Information in this document supersedes and replaces all information previously supplied.

The ST logo is a registered trademark of STMicroelectronics. All other names are the property of their respective owners.

© 2007 STMicroelectronics - All rights reserved

STMicroelectronics group of companies

Australia - Belgium - Brazil - Canada - China - Czech Republic - Finland - France - Germany - Hong Kong - India - Israel - Italy - Japan - Malaysia - Malta - Morocco - Singapore - Spain - Sweden - Switzerland - United Kingdom - United States of America

www.st.com